

April 7, 1998

TEL:805-498-2111 FAX:805-498-3804 WEB:http://www.semtech.com

DESCRIPTION

The EZ1585D is a high performance positive voltage regulator designed for use in applications requiring low dropout performance at full rated current. Additionally, the EZ1585D provides excellent regulation over variations in line, load and temperature.

Outstanding features include low dropout performance at rated current, fast transient response, internal current limiting and thermal shutdown protection of the output device. The EZ1585D has tight tolerance on reference voltage, $\pm 1\%$ at 25°C and $\pm 1.5\%$ over line, load and temperature, as well as a 6.0A maximum current. The EZ1585D is a three terminal regulator with adjustable output voltage available in the popular TO-220 package.

BLOCK DIAGRAM

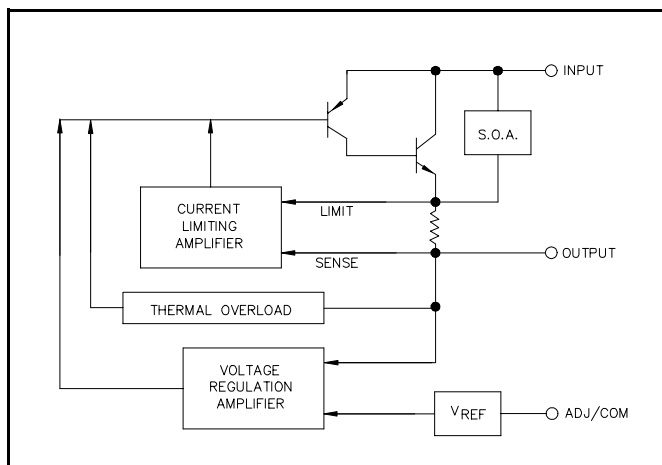

PIN CONFIGURATION

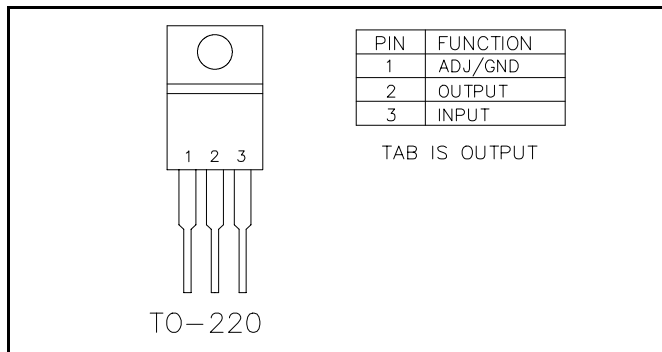

FEATURES

- Low dropout performance, 1.3V max.
- Full current rating over line and temperature
- Fast transient response
- $\pm 1.5\%$ total output regulation over line, load and temperature
- Adjust pin current max. 100 μA over temperature
- Adjustable output voltage
- Line regulation typically 0.015%
- Load regulation typically 0.05%
- TO-220 package

APPLICATIONS

- Pentium[®] Processor supplies

ORDERING INFORMATION

DEVICE	PACKAGE	V _{OUT} VOLTS
EZ1585DCT	TO-220	1.30 to 5.7

ABSOLUTE MAXIMUM RATINGS

Parameter	Symbol	Maximum	Units
Input Supply Voltage	V _{IN}	7	V
Power Dissipation	P _D	Internally Limited	W
Thermal Resistance Junction to Case Control Power	θ_{JC}	0.7 3.0	$^\circ\text{C/W}$
Thermal Resistance Junction to Ambient	θ_{JA}	50	$^\circ\text{C/W}$
Operating Junction Temperature Range	T _J	0 to 125	$^\circ\text{C}$
Storage Temperature Range	T _{STG}	-65 to 150	$^\circ\text{C}$
Lead Temperature (Soldering) 10 Sec	T _{LEAD}	260	$^\circ\text{C}$

April 7, 1998

ELECTRICAL CHARACTERISTICS

 Unless otherwise specified, Adj $I_o = 10\text{mA}$ to 6.0A ; $1.3\text{V} \leq (V_{IN} - V_{OUT}) \leq 2.6\text{V}$

Parameter	Symbol	Test Conditions			Test Limits			Units
		V_{IN}	I_o	$T_J^{(5)}$	Min	Typ	Max	
Reference Voltage ⁽¹⁾	V_{REF}	Note 7	$10\text{mA} \leq I_o \leq 6\text{A}$	25°C	1.238	1.250	1.262	V
		Note 8	$10\text{mA} \leq I_o \leq 5\text{A}$					
Adj Voltage Version		Note 7	$10\text{mA} \leq I_o \leq 6\text{A}$	O.T.	1.231		1.269	
		Note 8	$10\text{mA} \leq I_o \leq 5\text{A}$					
Line Regulation ⁽¹⁾	$REG_{(LINE)}$	Note 6		25°C		0.015	0.2	%
Adj Voltage Version			10mA	O.T.		0.035	0.2	
Load Regulation ⁽¹⁾	$REG_{(LOAD)}$	5V		25°C		0.05	0.3	%
				O.T.		0.2	0.4	
Dropout Voltage ⁽²⁾	V_D			25°C		1		V
			5A	O.T.		1.1	1.3	
			6A				1.8	
Current Limit	I_{CL}	Note 7		O.T.	6.0			A
		Note 8						
Temperature Coefficient	T_C	Note 6				0.005		%/°C
Adjust Pin Current	I_{ADJ}	Note 6		25°C	40	55	80	μA
				O.T.	20		100	
Adjust Pin Current Change	ΔI_{ADJ}			O.T.		0.2	5	μA
Temperature Stability	T_S	5V	0.5A	O.T.		0.5		%
Minimum Load Current Adj Voltage Version	I_O	5V		O.T.		5	10	mA
RMS Output Noise ⁽³⁾	V_N	Note 6		25°C		0.003		% V_O
Ripple Rejection Ratio ⁽⁴⁾	R_A	5V	5.0A	O.T.	60	72		dB

NOTES:

- (1) Low duty cycle pulse testing with Kelvin connections required.
- (2) $\Delta V_{OUT}, \Delta V_{REF} = 1\%$
- (3) Bandwidth of 10 Hz to 10 kHz.
- (4) 120 Hz input ripple, $C_{OUT} = 25\mu\text{F}$, $(V_{IN} - V_{OUT}) = 1.5\text{V}$.
- (5) Over Temp. (O.T.) = over specified operating junction temperature range.
- (6) $V_{IN} = 4.75$ to 5.25V .
- (7) $1.8\text{V} \leq (V_{IN} - V_{OUT}) \leq 2.6\text{V}$.
- (8) $1.3\text{V} \leq (V_{IN} - V_{OUT}) \leq 1.8\text{V}$.

April 7, 1998

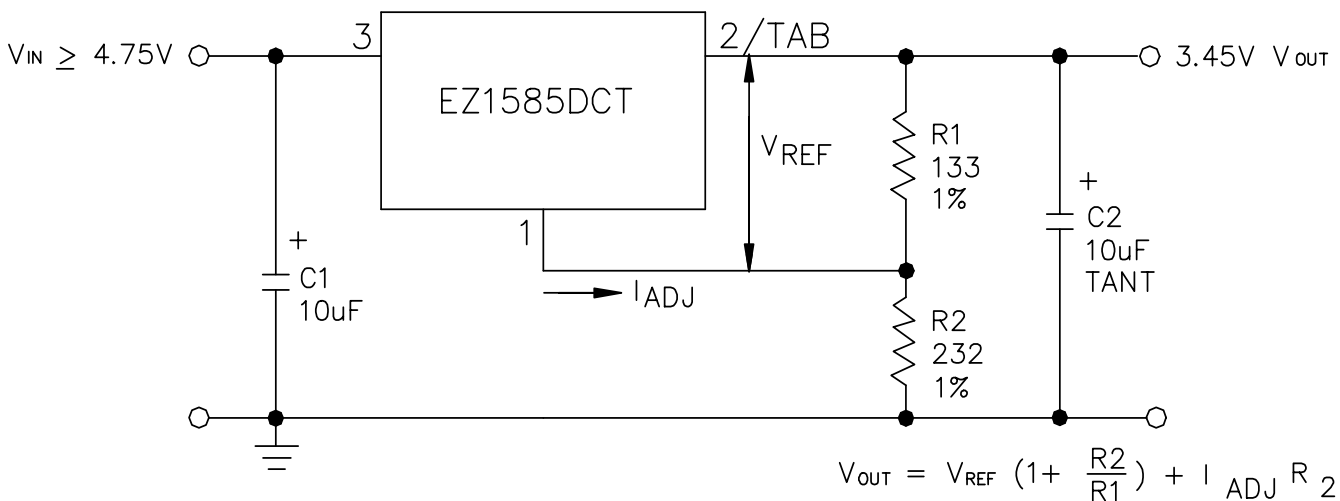
TYPICAL APPLICATIONS
ADJUSTABLE VOLTAGE REGULATOR ⁽¹⁾⁽²⁾

- (1) C1 NEEDED IF DEVICE IS FAR FROM FILTER CAPACITORS.
- (2) C2 REQUIRED FOR STABILITY.

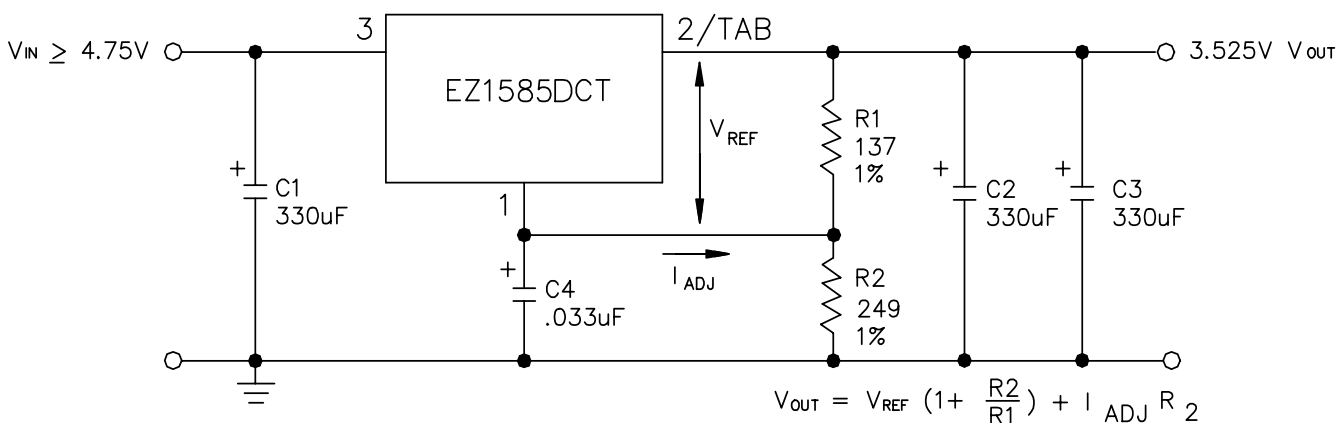
**RECOMMENDED CIRCUIT FOR THE
 INTEL PENTIUM PROCESSOR - P54C-VRE**

- (1) C1 NEEDED IF DEVICE IS FAR FROM FILTER CAPACITORS.
- (2) C2 AND C3 REQUIRED FOR STABILITY.
- (3) C1 = C2 = C3 = 330uF, 200m OHM ESR

April 7, 1998

DEVICE OUTLINE - TO-220
