

Fast CMOS Octal Buffer/Line Drivers

Features

- PI74FCT244/541T and PI74FCT2244/2541T are pin compatible with bipolar Fast Series at a higher speed and lower power consumption
- 25Ω series resistor on all outputs (FCT2XXX only)
- TTL input and output levels
- Low ground bounce outputs
- Extremely low static power
- Hysteresis on all inputs
- Industrial operating temperature range: -40°C to +85°C
- Packaging (Pb-free & Green available):
  - 20-pin 173-mil wide plastic TSSOP (L)
  - 20-pin 209-mil wide plastic SSOP (H)
  - 20-pin 150-mil wide plastic QSOP (Q)
  - 20-pin 150-mil wide plastic TQSOP (R)
  - 20-pin 300-mil wide plastic SOIC (S)
- Device models available upon request

Description

Pericom Semiconductor’s PI74FCT244T/541T and PI74FCT2244/2541T are 8-bit wide driver circuits, designed to be used in applications requiring high-speed and high-output drive. Ideal applications would include bus drivers, memory drivers, address drivers, and system clock drivers.

The PI74FCT541 and 2541T provide similar driver capabilities, but have their pins physically grouped by function. All inputs are located on one side of the package, while outputs are on the opposite side, allowing for a much simpler and denser board layout.

All PI74FCT2XXX devices have a built-in 25Ω series resistor on all outputs to reduce noise because of reflections, thus eliminating the need for an external terminating resistor.

Block Diagrams

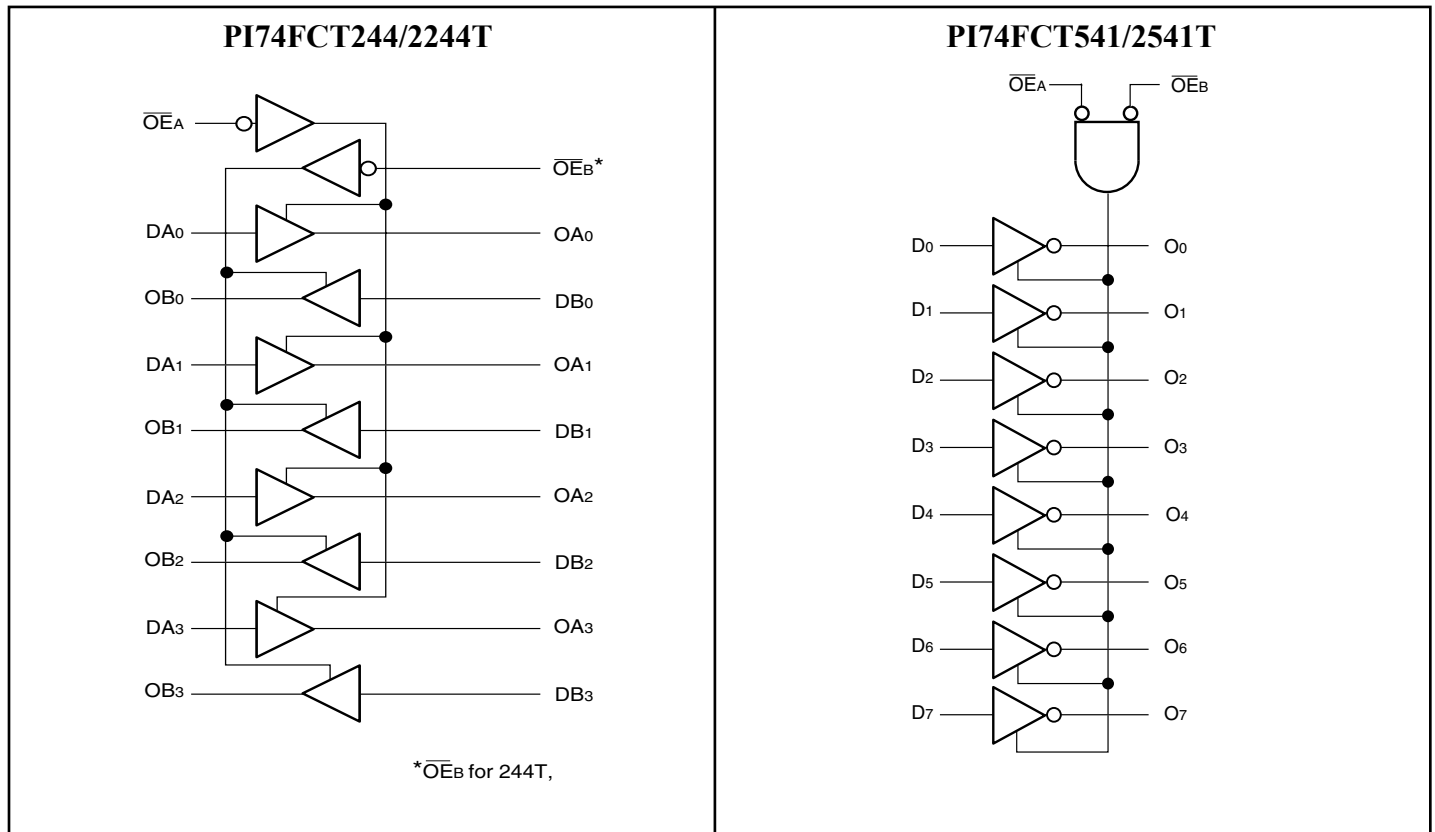

### Product Pin Description

Pin Name	Description
$\overline{OE_A}$ , $\overline{OE_B}$	3-State Output Enable Inputs (Active LOW)
$OE_B^{(1)}$	3-State Output Enable Input (Active HIGH)
D <sub>xx</sub>	Inputs
O <sub>xx</sub>	Outputs
GND	Ground
V <sub>CC</sub>	Power

### Truth Table

Inputs <sup>(1)</sup>				Outputs <sup>(1)</sup>	
$\overline{OE_A}$	$\overline{OE_B}$	$OE_B^{(2)}$	D	244	541
L	L	H	L	L	L
L	L	H	H	H	H
H	H	L	X	Z	Z

**Note:**

1. H = High Voltage Level, X = Don't Care, L = Low Voltage Level, Z = High Impedance
2.  $OE_B$  for 241 only.

### PI74FCT241/2241/244/2244T Pin Configuration

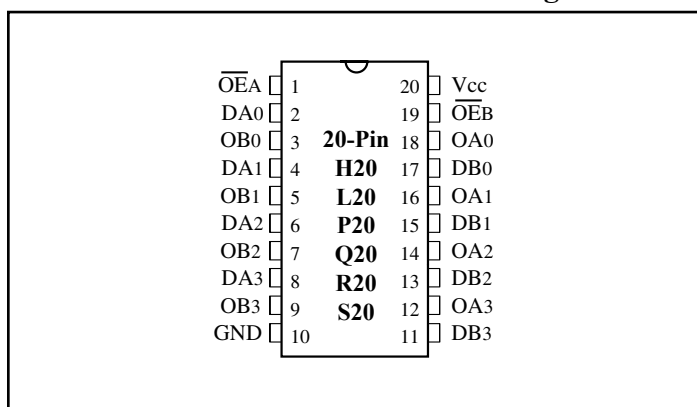

### PI74FCT540/541/2541T Pin Configuration

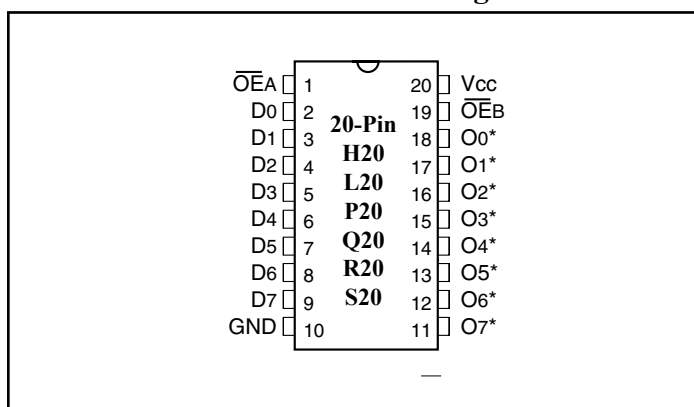

## Maximum Ratings

(Above which the useful life may be impaired. For user guidelines, not tested.)

Storage Temperature .....	-65°C to +150°C
Ambient Temperature with Power Applied .....	-40°C to +85°C
Supply Voltage to Ground Potential (Inputs & Vcc Only) .....	-0.5V to +7.0V
Supply Voltage to Ground Potential (Outputs & D/O Only) ...	-0.5V to +7.0V
DC Input Voltage .....	-0.5V to +7.0V
DC Output Current.....	120mA
Power Dissipation .....	0.5W

### Note:

Stresses greater than those listed under MAXIMUM RATINGS may cause permanent damage to the device. This is a stress rating only and functional operation of the device at these or any other conditions above those indicated in the operational sections of this specification is not implied. Exposure to absolute maximum rating conditions for extended periods may affect reliability.

## DC Electrical Characteristics (Over the Operating Range, TA = -40°C to +85°C, VCC = 5.0V ± 5%)

Parameters	Description	Test Conditions <sup>(1)</sup>		Min.	Typ <sup>(2)</sup>	Max.	Units
VOH	Output HIGH Voltage	VCC = Min., VIN = VIH or VIL	IOH = -15.0mA	2.4	3.0		V
VOL	Output LOW Current	VCC = Min., VIN = VIH or VIL	IOL = 64mA		0.3	0.55	
VOL	Output LOW Current	VCC = Min., VIN = VIH or VIL	IOL = 12mA (25ΩSeries)		0.3	0.50	
VIH	Input HIGH Voltage	Guaranteed Logic HIGH Level		2.0			
VIL	Input LOW Voltage	Guaranteed Logic LOW Level				0.8	
IiH	Input HIGH Current	VCC = Max.	VIN = VCC			1	μA
IiL	Input LOW Current	VCC = Max.	VIN = GND			-1	
IOZH	High Impedance	VCC = MAX.	VOU = 2.7V			1	
IOZL	Output Current		VOU = 0.5V			-1	
VIK	Clamp Diode Voltage	VCC = Min., IIN = -18mA			-0.7	-1.2	V
IOFF	Power Down Disable	VCC = GND, VOUT = 4.5V		—	—	100	μA
IOS	Short Circuit Current	VCC = Max. <sup>(3)</sup> , VOUT = GND		-60	-120		mA
VH	Input Hysteresis				200		

## Capacitance (TA = 25°C, f = 1 MHz)

Parameters <sup>(4)</sup>	Description	Test Conditions	Typ.	Max.	Units
CIN	Input Capacitance	VIN = 0V	6	10	pF
COUT	Output Capacitance	VOUT = 0V	8	12	

### Notes:

1. For Max. or Min. conditions, use appropriate value specified under Electrical Characteristics for the applicable device type.
2. Typical values are at Vcc = 5.0V, +25°C ambient and maximum loading.
3. Not more than one output should be shorted at one time. Duration of the test should not exceed one second.
4. This parameter is determined by device characterization but is not production tested.

**Power Supply Characteristics**

Parameters	Description	Test Conditions <sup>(1)</sup>		Min.	Typ <sup>(2)</sup>	Max.	Units
I <sub>CC</sub>	Quiescent Power Supply Current	V <sub>CC</sub> = Max.	V <sub>IN</sub> = GND or V <sub>CC</sub>		0.1	500	μA
ΔI <sub>CC</sub>	Supply Current per Input @ TTL HIGH	V <sub>CC</sub> = Max.	V <sub>IN</sub> = 3.4V <sup>(3)</sup>		0.5	2.5	mA
I <sub>CCD</sub>	Supply Current per Input per MHz <sup>(4)</sup>	V <sub>CC</sub> = Max., Outputs Open $\overline{OE}_A = \overline{OE}_B = \text{GND}$ or $\overline{OE}_A = \text{GND}, \overline{OE}_B = \text{VCC}$ One Bit Toggling 50% Duty Cycle	V <sub>IN</sub> = V <sub>CC</sub> V <sub>IN</sub> = GND		0.15	0.25	mA/ MHz
I <sub>C</sub>	Total Power Supply Current <sup>(6)</sup>	V <sub>CC</sub> = Max., Outputs Open f <sub>i</sub> = 10 MHz 50% Duty Cycle $\overline{OE}_A = \overline{OE}_B = \text{GND}$ or $\overline{OE}_A = \text{GND}, \overline{OE}_B = \text{VCC}$ One Bit Toggling	V <sub>IN</sub> = V <sub>CC</sub> V <sub>IN</sub> = GND		1.5	3.5 <sup>(5)</sup>	mA
			V <sub>IN</sub> = 3.4V V <sub>IN</sub> = GND		1.8	4.5 <sup>(5)</sup>	
		V <sub>CC</sub> = Max., Outputs Open f <sub>i</sub> = 2.5 MHz 50% Duty Cycle $\overline{OE}_A = \overline{OE}_B = \text{GND}$ or $\overline{OE}_A = \text{GND}, \overline{OE}_B = \text{VCC}$ Eight Bits Toggling	V <sub>IN</sub> = V <sub>CC</sub> V <sub>IN</sub> = GND		3.0	6.0 <sup>(5)</sup>	
			V <sub>IN</sub> = 3.4V V <sub>IN</sub> = GND		5.0	14.0 <sup>(5)</sup>	

**Notes:**

- For Max. or Min. conditions, use appropriate value specified under Electrical Characteristics for the applicable device.
- Typical values are at V<sub>CC</sub> = 5.0V, +25°C ambient.
- Per TTL driven input (V<sub>IN</sub> = 3.4V); all other inputs at V<sub>CC</sub> or GND.
- This parameter is not directly testable, but is derived for use in Total Power Supply Calculations.
- Values for these conditions are examples of the I<sub>CC</sub> formula. These limits are guaranteed but not tested.
- I<sub>C</sub> = I<sub>QUIESCENT</sub> + I<sub>INPUTS</sub> + I<sub>DYNAMIC</sub>

$$I_C = I_{CC} + \Delta I_{CC} D_H N_T + I_{CCD} (f_{CP}/2 + f_i N_i)$$

I<sub>CC</sub> = Quiescent Current

ΔI<sub>CC</sub> = Power Supply Current for a TTL High Input (V<sub>IN</sub> = 3.4V)

D<sub>H</sub> = Duty Cycle for TTL Inputs High

N<sub>T</sub> = Number of TTL Inputs at D<sub>H</sub>

I<sub>CCD</sub> = Dynamic Current Caused by an Input Transition Pair (HLH or LHL)

f<sub>CP</sub> = Clock Frequency for Register Devices (Zero for Non-Register Devices)

f<sub>i</sub> = Input Frequency

N<sub>i</sub> = Number of Inputs at f<sub>i</sub>

All currents are in milliamps and all frequencies are in megahertz.

**PI74FCT244/2244T Switching Characteristics over Operating Range**

Parameters	Description	Conditions <sup>(1)</sup>	244T/2244T		244AT/2244AT		244CT/2244CT		244DT		Units
			Com.		Com.		Com.		Com.		
			Min	Max	Min	Max	Min	Max	Min	Max	
t <sub>PLH</sub> t <sub>PHL</sub>	Propagation Delay	C <sub>L</sub> = 50pF	1.5	6.5	1.5	4.8	1.5	4.1	1.5	3.6	ns
t <sub>PZH</sub> t <sub>PZL</sub>	Output Enable Time O <sub>EX</sub> to ON		1.5	8.0	1.5	6.2	1.5	5.8	1.5	4.8	ns
t <sub>PHZ</sub> t <sub>PLZ</sub>	Output Disable Time <sup>(3)</sup> O <sub>EX</sub> to ON		1.5	7.0	1.5	5.6	1.5	5.2	1.5	4.0	ns

**Notes:**

1. See test circuit and wave forms.
2. Minimum limits are guaranteed but not tested on Propagation Delays.
3. This parameter is guaranteed but not production tested.

**PI74FCT541/2541T Switching Characteristics over Operating Range**

Parameters	Description	Conditions <sup>(1)</sup>	541T/2541T		541AT/ 2541AT		541CT/ 2541CT		541DT		Units
			Com.		Com.		Com.		Com.		
			Min	Max	Min	Max	Min	Max	Min	Max	
t <sub>PLH</sub> t <sub>PHL</sub>	Propagation Delay DN to ON	C <sub>L</sub> = 50pF R <sub>L</sub> = 500Ω	1.5	6.0	1.5	4.8	1.5	4.1	1.5	3.8	ns
t <sub>PZH</sub> t <sub>PZL</sub>	Output Enable Time O <sub>EX</sub> to ON		1.5	9.5	1.5	6.2	1.5	5.8	1.5	5.2	ns
t <sub>PHZ</sub> t <sub>PLZ</sub>	Output Disable Time <sup>(3)</sup> O <sub>EX</sub> to ON		1.5	6.5	1.5	5.6	1.5	5.2	1.5	5.2	ns

**Notes:**

1. See test circuit and wave forms.
2. Minimum limits are guaranteed but not tested on Propagation Delays.
3. This parameter is guaranteed but not production tested.

**Ordering Information: PI74FCT244T**

Ordering Code	Package Code	Speed Grade	Package Description
PI74FCT244TH	H	Blank	20-pin 209-mil wide plastic SSOP
PI74FCT244TL	L	Blank	20-pin 173-mil wide plastic TSSOP
PI74FCT244TLE	L	Blank	Pb-free & Green, 20-pin 173-mil wide plastic TSSOP
PI74FCT244TQ	Q	Blank	20-pin 150-mil wide plastic QSOP
PI74FCT244TS	S	Blank	20-pin 300-mil wide plastic SOIC
PI74FCT244ATH	H	A	20-pin 209-mil wide plastic SSOP
PI74FCT244ATL	L	A	20-pin 173-mil wide plastic TSSOP
PI74FCT244ATQ	Q	A	20-pin 150-mil wide plastic QSOP
PI74FCT244ATS	S	A	20-pin 300-mil wide plastic SOIC
PI74FCT244ATSE	S	A	Pb-free & Green, 20-pin 300-mil wide plastic SOIC
PI74FCT244CTH	H	C	20-pin 209-mil wide plastic SSOP
PI74FCT244CTL	L	C	20-pin 173-mil wide plastic TSSOP
PI74FCT244CTQ	Q	C	20-pin 150-mil wide plastic QSOP
PI74FCT244CTS	S	C	20-pin 300-mil wide plastic SOIC
PI74FCT244DTQ	Q	D	20-pin 150-mil wide plastic QSOP
PI74FCT244DTS	S	D	20-pin 300-mil wide plastic SOIC
PI74FCT244DTSE	S	D	Pb-free & Green, 20-pin 300-mil wide plastic SOIC

**Ordering Information: PI74FCT2244T**

Ordering Code	Package Code	Speed Grade	Package Description
PI74FCT2244TQ	Q	Blank	20-pin 150 mil wide plastic QSOP
PI74FCT2244TS	S	Blank	20-pin 300 mil wide plastic SOIC
PI74FCT2244ATH	H	A	20-pin 209 mil wide plastic SSOP
PI74FCT2244ATL	L	A	20-pin 173 mil wide plastic TSSOP
PI74FCT2244ATQ	Q	A	20-pin 150 mil wide plastic QSOP
PI74FCT2244ATS	S	A	20-pin 300 mil wide plastic SOIC
PI74FCT2244CTL	L	C	20-pin 173 mil wide plastic TSSOP
PI74FCT2244CTQ	Q	C	20-pin 150 mil wide plastic QSOP
PI74FCT2244CTS	S	C	20-pin 300 mil wide plastic SOIC

**Ordering Information: PI74FCT541T**

Ordering Code	Package Code	Speed Grade	Package Description
PI74FCT541TQ	Q	Blank	20-pin 150-mil wide plastic QSOP
PI74FCT541TQE	Q	Blank	Pb-free & Green, 20-pin 150-mil wide plastic QSOP
PI74FCT541TS	S	Blank	20-pin 300-mil wide plastic SOIC
PI74FCT541ATL	L	A	20-pin 173-mil wide plastic TSSOP
PI74FCT541ATQ	Q	A	20-pin 150-mil wide plastic QSOP
PI74FCT541ATS	S	A	20-pin 300-mil wide plastic SOIC
PI74FCT541ATSE	S	A	Pb-free & Green, 20-pin 300-mil wide plastic SOIC
PI74FCT541ATH	H	A	20-pin 209-mil wide plastic SSOP
PI74FCT541CTL	L	C	20-pin 173-mil wide plastic TSSOP
PI74FCT541CTQ	Q	C	20-pin 150-mil wide plastic QSOP
PI74FCT541CTS	S	C	20-pin 300-mil wide plastic SOIC
PI74FCT541CTH	H	C	20-pin 209-mil wide plastic SSOP

**Ordering Information: PI74FCT2541T**

Ordering Code	Package Code	Speed Grade	Package Description
PI74FCT2541TL	L	Blank	20-pin 173 mil wide plastic TSSOP
PI74FCT2541TQ	Q	Blank	20-pin 150 mil wide plastic QSOP
PI74FCT2541TS	S	Blank	20-pin 300 mil wide plastic SOIC
PI74FCT2541ATH	H	A	20-pin 209 mil wide plastic SSOP
PI74FCT2541ATL	L	A	20-pin 173 mil wide plastic TSSOP
PI74FCT2541ATQ	Q	A	20-pin 150 mil wide plastic QSOP
PI74FCT2541ATS	S	A	20-pin 300 mil wide plastic SOIC
PI74FCT2541CTH	H	C	20-pin 209 mil wide plastic SSOP
PI74FCT2541CTL	L	V	20-pin 173 mil wide plastic TSSOP

**Notes:**

1. Thermal characteristics can be found on the company web site at [www.pericom.com/packaging/](http://www.pericom.com/packaging/)