

TENTATIVE TOSHIBA BIPOLAR LINEAR INTEGRATED CIRCUIT SILICON MONOLITHIC

TA8876FA

FOR LCD TVS, PIF, QIF, AND SIF SYSTEMS

FEATURES

PIF circuit

- High-speed response peak AGC with dual time constant
- Forward / Reverse RF AGC output
- Output with black noise inverter
- Output without black noise inverter
- Video output adjustment
- Single polarity AFT output
- Built-in sync. separation circuit

QIF circuit

- Intercarrier demodulation block with same structure as in PIF circuit
- Independent mean value AGC detection

SIF circuit

- Sound IF amplification and detection
- Quadratcher-type detector circuit
- Use of a ceramic discriminator device makes the SIF circuit adjustment-free.
- Sound mute switch

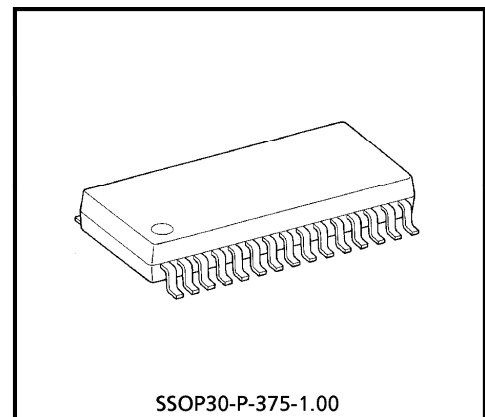

SSOP30-P-375-1.00

Weight : 0.63 g (Typ.)

980910EBA2

- TOSHIBA is continually working to improve the quality and the reliability of its products. Nevertheless, semiconductor devices in general can malfunction or fail due to their inherent electrical sensitivity and vulnerability to physical stress. It is the responsibility of the buyer, when utilizing TOSHIBA products, to observe standards of safety, and to avoid situations in which a malfunction or failure of a TOSHIBA product could cause loss of human life, bodily injury or damage to property. In developing your designs, please ensure that TOSHIBA products are used within specified operating ranges as set forth in the most recent products specifications. Also, please keep in mind the precautions and conditions set forth in the TOSHIBA Semiconductor Reliability Handbook.
- The products described in this document are subject to the foreign exchange and foreign trade laws.
- The information contained herein is presented only as a guide for the applications of our products. No responsibility is assumed by TOSHIBA CORPORATION for any infringements of intellectual property or other rights of the third parties which may result from its use. No license is granted by implication or otherwise under any intellectual property or other rights of TOSHIBA CORPORATION or others.
- The information contained herein is subject to change without notice.

BLOCK DIAGRAM

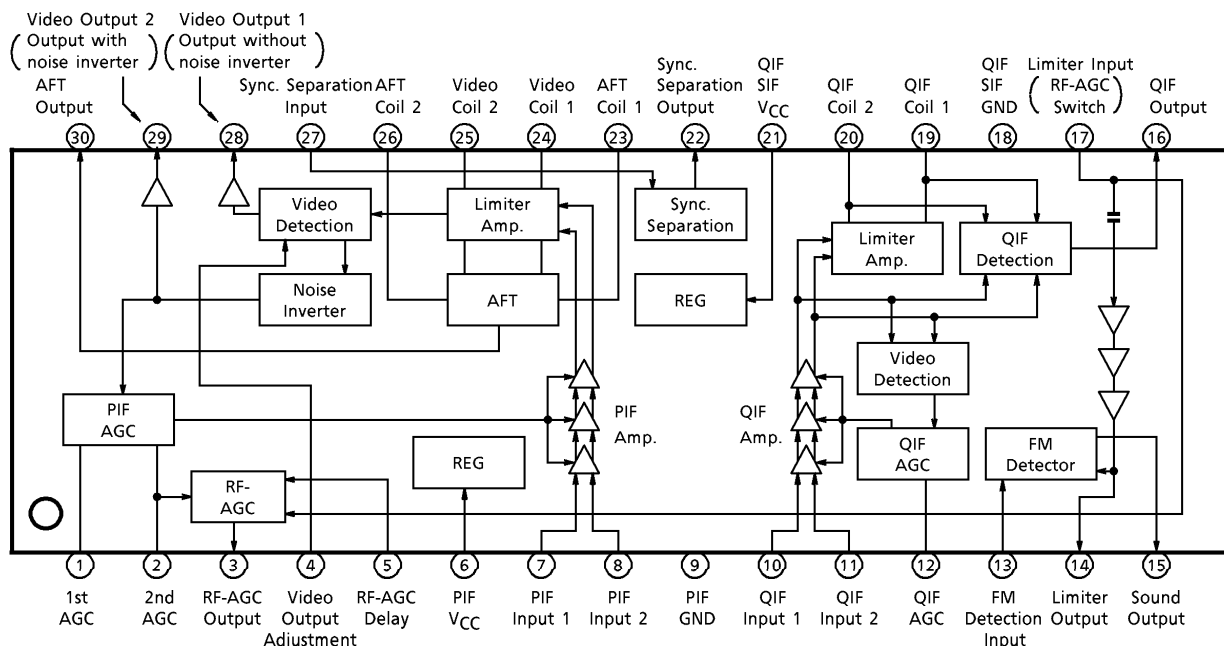

**TERMINAL FUNCTION
TERMINAL LIST**

PIN No.	PIN NAME	FUNCTION
1	1st-AGC	1st AGC filter terminal
2	2nd-AGC	2nd AGC filter terminal
3	RF-AGC Output	RF AGC output (Reverse / Forward switchable)
4	VIDEO ADJ.	Can adjust video output. (Normally connect Condenser.)
5	AGC Delay	RF AGC delay point adjustment terminal
6	PIF V _{CC}	PIF circuit power supply terminal
7	PIF Input 1	PIF signal input terminal
8	PIF Input 2	PIF signal input terminal
9	PIF GND	PIF circuit GND terminal
10	QIF Input 1	QIF signal input terminal
11	QIF Input 2	QIF signal input terminal
12	QIF AGC	QIF AGC filter terminal
13	FM Detection Input	Sound FM detector input terminal
14	Limiter Output	Sound limiter output terminal
15	Sound Output	Sound output terminal
16	QIF Output	QIF signal output terminal
17	Limiter Input (RF-AGC Switch)	Sound limiter input terminal (Also used for RF-AGC switching)
18	QIF / SIF GND	QIF and SIF circuit GND terminal

PIN No.	PIN NAME	FUNCTION
19	QIF Coil 1	QIF detector carrier extraction terminal
20	QIF Coil 2	QIF detector carrier extraction terminal
21	QIF/SIF V _{CC}	QIF and SIF circuit power supply terminal
22	Sync. Separation Output	Sync. signal output terminal
23	AFT Coil 1	AFT detector coil terminal
24	Video Coil 1	PIF detector carrier extraction terminal
25	Video Coil 2	PIF detector carrier extraction terminal
26	AFT Coil 2	AFT detector coil terminal
27	Sync. Separation Input	Sync. signal input terminal
28	Video Output 1 (Output without noise inverter)	Video detection output terminal (Output without noise inverter)
29	Video Output 2 (Output with noise inverter)	Video detection output terminal (Output with noise inverter)
30	AFT Output	AFT control voltage output terminal

TERMINAL FUNCTION

PIN No.	PIN NAME	FUNCTION	INTERFACE CIRCUIT
1 2	PIF AGC	Uses dual time constant to speed up AGC. To mute picture, connect pin 1 to GND.	
3	RF AGC Output	Emitter follower-type RF AGC output. Max. output 3 mA (typ.)	

PIN No.	PIN NAME	FUNCTION	INTERFACE CIRCUIT
4	Video Output Adjustment	Used to adjust video output amplitude. This pin has internal bias. Opening this terminal fixes video output amplitude to 1.0 V _{p-p} . Toshiba recommends connecting 0.01 μF to prevent noise.	
5	RF AGC Delay	Changing comparator reference voltage adjusts RF AGC delay point.	
6	PIF VCC	Insert bypass condenser between this terminal and pin 9.	—
7 8	PIF Input	PIF signal input terminal. Input impedance is 5 kΩ (typ.).	
9	PIF GND	Insert bypass condenser between this terminal and pin 6.	—

PIN No.	PIN NAME	FUNCTION	INTERFACE CIRCUIT
10 11	QIF Input	QIF signal input terminal. Input impedance is 5 kΩ (typ.).	
12	QIF AGC	AGC terminal of QIF detector circuit.	
13 15	FM Detection Input Sound Output	Sound detection terminal for coil, which is connected between this terminal and pin 14. FM detector circuit output terminal.	
14	Limiter Output	Sound detection terminal for coil, which is connected between this terminal and pin 13. Applying ceramic discriminator sets this circuit to non-adjustable circuit. To mute sound, connect pin 13 to GND.	

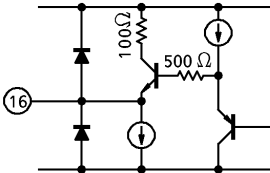
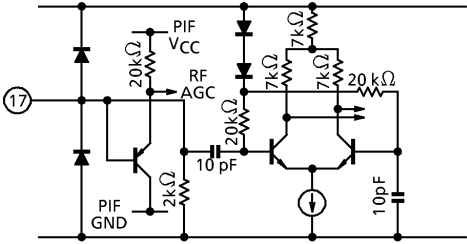
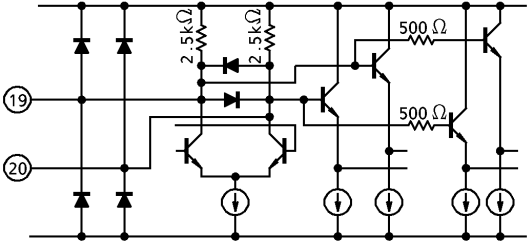
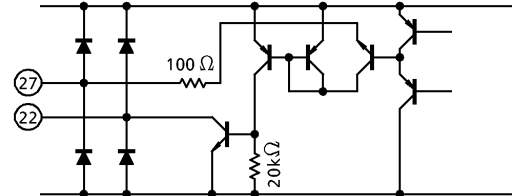
PIN No.	PIN NAME	FUNCTION	INTERFACE CIRCUIT
16	QIF Output	QIF detection output terminal. Connect this terminal to SIF input via BPF. For BPF matching, see function of pin 17.	
17	SIF Input RF AGC SW	Connect to pin 16, via BPF. This terminal also functions as output polarity switching circuit of RF AGC output. Internal impedance is designed to be 2 kΩ. Externally connecting 2 kΩ between this terminal and GND outputs reverse AGC and changes input impedance to 1 kΩ. Externally connecting a 2 kΩ-resistor between this terminal and V _{CC} outputs forward AGC and changes input impedance to 1 kΩ.	
18	QIF GND SIF	Insert bypass condenser between this terminal and pin 21.	—
19 20	QIF Coil	This terminal connects QIF detection coil.	
21	QIF SIF V _{CC}	Insert bypass condenser between this terminal and pin 18.	—
22 27	Sync. Separation	Sync. separation circuit required for tuner's search function.	

PIN No.	PIN NAME	FUNCTION	INTERFACE CIRCUIT
24 25	Video Coil	Connects video detection coil.	
23 26	AFT Coil	Connects AFT detection coil. To improve AFT characteristics, two-pin-type circuit is used.	
28 29	Video Signal Output	Video signal output terminal. Pin 28 is output that does not go through noise inverter, and can thus be used for diversity processing, for example. Pin 29 incorporates built-in noise inversion circuit. Output amplitude from both of these terminals can be adjusted using pin 4.	
30	AFT Output	AFT detector output terminal based on double balanced-type multiplier.	

MAXIMUM RATINGS (Ta = 25°C)

CHARACTERISTIC	SYMBOL	RATING	UNIT
Power Supply Voltage	V _{CC}	8	V
Power Dissipation	P _D (Note)	500	mW
Operating Temperature	T _{opr}	- 20~75	°C
Storage Temperature	T _{stg}	- 55~150	°C

(Note) When using the device at above Ta = 25°C, decrease the power dissipation by 4 mW for each increase of 1°C.

RECOMMENDED POWER SUPPLY

PIN No.	PIN NAME	MIN.	TYP.	MAX.	UNIT
6	PIF V _{CC}	3.5	4.5	7.5	V
21	QIF SIF V _{CC}	3.5	4.5	7.5	V

ELECTRICAL CHARACTERISTICS

DC CHARACTERISTICS (Unless otherwise specified, V_{CC} = 4.5 V, Ta = 25°C)

CHARACTERISTIC		SYMBOL	TEST CIR-CUIT	TEST CONDITION	MIN.	TYP.	MAX.	UNIT
Terminal Voltage	Pin 3 (1)	V3 (L)	1	SW ₂ = a	0.0	—	0.5	V
	Pin 3 (2)	V3 (H)		SW ₂ = b	3.5	3.8	4.0	
	Pin 7	V7			2.4	2.9	3.4	
	Pin 8	V8			2.4	2.9	3.4	
	Pin 10	V 10			2.4	2.9	3.4	
	Pin 11	V 11			2.4	2.9	3.4	
	Pin 13	V 13			3.4	3.7	4.0	
	Pin 16	V 16			1.5	2.0	2.5	
	Pin 19	V 19			3.8	4.1	4.4	
	Pin 20	V 20			3.8	4.1	4.4	
	Pin 23	V 23			4.2	—	4.5	
	Pin 24	V 24			3.8	4.1	4.4	
	Pin 25	V 25			3.8	4.1	4.4	
	Pin 26	V 26			4.2	—	4.5	
	Pin 28	V 28			1.5	2.0	2.5	
Pin 29	V 29		1.5	2.0	2.5			
Pin 30	V 30		1.3	2.3	3.3			

AC CHARACTERISTICS (Unless otherwise specified, $V_{CC} = 4.5\text{ V}$, $T_a = 25^\circ\text{C}$)
PIF circuit (When using the specified coil)

CHARACTERISTIC	SYMBOL	TEST CIR-CUIT	TEST CONDITION	MIN.	TYP.	MAX.	UNIT
Power Supply Current At No Signal	IPIF	1		10	15	20	mA
Input Sensitivity	VinPMIN	2	(Note 1)	—	30	35	dB_μV
Maximum Input Level	VinPMIX	2	(Note 2)	100	105	—	dB_μV
No-Signal Level	V _{OUT}	2	(Note 3)	1.5	2.0	2.5	V
Sync. Tip Level	V _{SYNC}	2	(Note 4)	0.6	0.8	1.0	V
Video Output Amplitude	VDp	2	(Note 5)	0.7	1.0	1.3	V_{p-p}
Video S/N Ratio	S/N	2	(Note 6)	50	60	—	dB
Detection Output Bandwidth	BW	2	(Note 7)	4.0	5.0	—	MHz
Black Noise Inverter Level	VBTH	2	(Note 8)	0.2	0.5	0.8	V
Black Noise Clamp Level	VBCL			1.0	1.2	1.4	
Carrier Wave Rejection Ratio	CLP	2	(Note 9)	50	—	—	dB
Harmonic Rejection Ratio	CLP2	2	(Note 10)	50	—	—	dB
Intermodulation	IMP	2	(Note 11)	35	—	—	dB
Differential Gain	DG	2	(Note 12)	—	5.0	10.0	%
Differential Phase	DP			—	3.0	8.0	°
AFT Sensitivity	$\Delta f / \Delta V$	2	(Note 13)	10	20	30	kHz/V
AFT Mute Voltage	VMUTE	2	(Note 14)	2.0	2.3	2.6	V
AFT Minimum Output Voltage	VA MIN	2	(Note 15)	—	—	0.5	V
AFT Maximum Output Voltage	VA MAX	2	(Note 16)	4.0	—	—	V
RF AGC Maximum Voltage	VRFAGC	1	(Note 17)	3.5	3.8	4.0	V
RF AGC Output Current	IRFAGC	1	(Note 18)	3.0	—	—	mA
Detection Output Power Supply Dependence	VDp / V _{CC}	2	(Note 19)	—	±5	—	% / V
Input Impedance	RINp	—	(Note 20)	—	5.0	—	$\text{k}\Omega$
	CINp			—	3.8	—	pF

QUASI circuit (When using the specified coil)

CHARACTERISTIC	SYMBOL	TEST CIR-CUIT	TEST CONDITION	MIN.	TYP.	MAX.	UNIT
Power Supply Current At No Signal	IQ-SIF	1		15	20	25	mA
Input Sensitivity	VinQMIN	2	(Note 21)	—	30	35	dB μ V
Maximum Input Level	VinQMAX	2	(Note 22)	100	105	—	dB μ V
Gain Reduction	GRq	2	(Note 23)	—	65	—	dB
4.5 MHz Output Level	V4.5	2	(Note 24)	100	108	115	dB μ V
Carrier Wave Rejection Ratio	CLq	2	(Note 25)	50	—	—	dB
Harmonic Rejection Ratio	CLq2	2	(Note 26)	50	—	—	dB
Detection Output Power Supply Dependence	VDq / VCC	2	(Note 27)	—	± 5	—	% / V
Input Impedance	RINq	—	(Note 28)	—	5.0	—	k Ω
	CINq			—	3.8	—	pF

SIF circuit (When using the specified coil)

CHARACTERISTIC	SYMBOL	TEST CIR-CUIT	TEST CONDITION	MIN.	TYP.	MAX.	UNIT
Limiting Sensitivity	VLIM	2	(Note 29)	—	43	48	dB μ V
Sound Detection Output	VDs	2	(Note 30)	350	450	550	mV _{rms}
Sound S/N Ratio	S/N	2	(Note 31)	50	60	—	dB
- 3 dB Bandwidth	BW-3	2	(Note 32)	60	90	120	kHz
AM Suppression Ratio	AMR	2	(Note 33)	40	60	—	dB
Distortion Ratio	THD	2	(Note 34)	—	0.5	1.5	%
Detection Output Power Supply Dependence	VDs / VCC	2	(Note 35)	—	± 10	—	% / V
Input Impedance	RINs	—	(Note 36)	—	2.0	—	k Ω
	CINs			—	10.0	—	pF

Sync. separation circuit

CHARACTERISTIC	SYMBOL	TEST CIR-CUIT	TEST CONDITION	MIN.	TYP.	MAX.	UNIT
Sync. Separation Input Voltage	Vsync. IN	2		1.6	2.1	2.6	V
Sync. Separation Min. Voltage	Vsync. MIN	2	15 k Ω - load	—	—	0.4	V
Sync. Separation Max. Voltage	Vsync. MAX	2		4.3	4.5	—	V

TEST CONDITIONS

< PIF circuit >

(Note 1) Input sensitivity

PIF input : f = 58.75 MHz, fm = 15.75 kHz, 30% AM, 84 dB μ V.

Gradually reduce the input level. Measure the input level when the detection output at video output-2 will be -3 dB.

(Note 2) Maximum input level

PIF input : f = 58.75 MHz, fm = 15.75 kHz, 30% AM, 84 dB μ V.

Gradually raise the input level. Measure the input level when the detection output at video output-2 is at the noise inverter threshold.

(Note 3) No-signal level

PIF input : No input. 2nd AGC terminal : GND

Measure DC voltage at video output-2.

(Note 4) Sync. Tip level

PIF input : f = 58.75 MHz, standard television signal (V/S = 10 : 4 ramp waveform), 87.5% AM, 84 dB μ V.

Measure sync. Tip DC voltage at video output-2.

(Note 5) Video output amplitude

PIF input : f = 58.75 MHz, standard television signal (V/S = 10 : 4 ramp waveform), 87.5% AM, 84 dB μ V.

Measure amplitude level at video output-2.

(Note 6) Video S/N ratio

PIF input : f = 58.75 MHz, fm = 15.75 kHz, 30% AM, 84 dB μ V.

Using the RMS voltmeter, measure the detection output at video output-2.

Then, using the RMS voltmeter, measure the video detection output without modulation.

$$S/N = 20 \log \left[\frac{\text{Value with modulation (mV}_{rms})}{\text{Value without modulation (mV}_{rms})} \right] \times 6 \text{ [dB]}$$

(Note 7) Detection output bandwidth

PIF input : $f = 58.75 \text{ MHz}$, $84 \text{ dB}\mu\text{V}$ CW.

Measure 2nd AGC terminal voltage and fix the terminal to that voltage using the external power supply.

Then, input the following composite signals to the PIF input.

- (1) SG 1 : 58.75 MHz , $84 \text{ dB}\mu\text{V}$ (Frequency fixed)
- (2) SG 2 : $58.65 \text{ MHz} \sim 45 \text{ MHz}$, $64 \text{ dB}\mu\text{V}$ (Frequency variable)

Monitor video output-2 with a spectrum analyzer. Vary SG2 to find frequency f when the detection output will be -3 dB .

Calculate the difference between that frequency and 58.75 MHz .

(Note 8) Black noise inverter, clamp level

PIF input : $f = 58.75 \text{ MHz}$, $f_m = 15.75 \text{ kHz}$, $30\% \text{ AM}$, $84 \text{ dB}\mu\text{V}$.

Measure the 2nd AGC terminal voltage and fix the terminal to that voltage using the external power supply.

Then, gradually raise the 2nd AGC terminal voltage and fix the voltage when a waveform like that in the accompanying diagram is output.

At that time, the A and B voltages are :

- A : Black noise inverter level
- B : Black noise clamp level

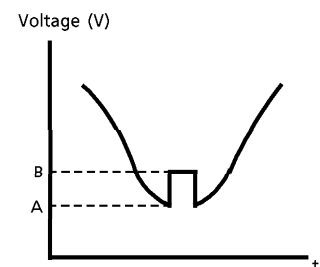

(Note 9) Carrier wave rejection ratio

PIF input : $f = 58.75 \text{ MHz}$, $f_m = 15.75 \text{ kHz}$, $78\% \text{ AM}$, $84 \text{ dB}\mu\text{V}$.

Monitor video output-2 detection output using a spectrum analyzer.

Measure the ratios of the 15.75 kHz and 58.75 MHz components.

(Note 10) Harmonic rejection ratio

Measure as in Note 9, above, and calculate the secondary harmonic level (117.5 MHz component) at video output-2.

(Note 11) Intermodulation

PIF input : Input the following composite signals to the PIF input.

- (1) SG 1 : 58.75 MHz (P) $84 \text{ dB}\mu\text{V}$
- (2) SG 2 : 54.25 MHz (S) $74 \text{ dB}\mu\text{V}$
- (3) SG 2 : 55.17 MHz (C) $74 \text{ dB}\mu\text{V}$

Monitor the video output-2 detection output waveform. Apply external voltage to the 2nd AGC terminal so that the waveform's lowest level matches the sync. Tip level.

Using a spectrum analyzer, measure the difference between the level of the chroma signal component of the video output-2 and the 920 kHz signal component.

(Note 12) Differential gain, Differential phase

PIF input : f = 58.75 MHz, standard television signal (V/S = 10 : 4 ramp waveform, 87.5% AM, 84 dB μ V).

Measure the differential gain and differential phase with a vector scope.

(Note 13) AFT sensitivity

PIF input : f = 58.75 MHz, 84 dB μ V, CW.

Input the above signal and adjust the AFT coil so that the AFT output pin voltage is 2.5 \pm 0.3 V.

Measure the output voltage differential (ΔV) of the AFT output pin when the frequency is raised by 20 kHz. Then, calculate the ratio using the following formula.

$$\frac{\Delta f}{\Delta V} = \frac{20}{\Delta V} \text{ [kHz/V]}$$

(Note 14) AFT mute voltage

PIF Input : No input. 2nd AGC terminal : GND. AFT coil terminal : GND.

Measure the AFT output terminal voltage.

(Note 15) AFT minimum output voltage

PIF input : f = 59.25 MHz, 84 dB μ V, CW.

Measure the AFT output pin voltage.

(Note 16) AFT maximum output voltage

PIF Input : f = 58.25 MHz, 84 dB μ V, CW.

Measure the AFT output terminal voltage.

(Note 17) RF AGC maximum output

PIF input : No input.

Set the RF AGC delay adjustment to the V_{CC} side.

Measure the RF AGC output terminal voltage.

(Note 18) RF AGC output current

PIF input : No input.

Turn switch 1 on. Measure the output current.

(Note 19) Detection output power supply dependence

PIF input : f = 58.75 MHz, standard television signal (V/S = 10 : 4 ramp waveform), 87.5% AM, 84 dB μ V.

Measure the video detection output.

Next, measure the video detection output when the power supply voltage is ± 1 V of the typ. level. Calculate the ratio.

(Note 20) Input impedance

Connect an impedance analyzer to the PIF input terminal. Measure the input resistance and the input capacitance.

< QIF circuit >

(Note 21) Input sensitivity

QIF input : Input the following composite signals to the QIF input.

- (1) $f = 58.75 \text{ MHz}$ $84 \text{ dB}\mu\text{V}$, CW.
- (2) $f = 54.25 \text{ MHz}$ $74 \text{ dB}\mu\text{V}$, CW.

Gradually reduce the composite signal level. Measure the input level when the 4.5 MHz detection output at the QIF output terminal will be 1/2.

(Note 22) Maximum input level

QIF input : Input the following composite signals to the QIF input.

- (1) $f = 58.75 \text{ MHz}$ $84 \text{ dB}\mu\text{V}$, CW.
- (2) $f = 54.25 \text{ MHz}$ $74 \text{ dB}\mu\text{V}$, CW.

Gradually raise the composite signal level. Measure the input level when the 4.5 MHz detection output at the QIF output terminal changes by $\pm 0.5 \text{ dB}$.

(Note 23) Gain reduction

$\text{GR} = (\text{Maximum input} - \text{Input sensitivity}) \quad [\text{dB}]$

(Note 24) 4.5 MHz output

QIF input : Input the following composite signals to the QIF input.

- (1) $f = 58.75 \text{ MHz}$ $84 \text{ dB}\mu\text{V}$, CW.
- (2) $f = 54.25 \text{ MHz}$ $74 \text{ dB}\mu\text{V}$, CW.

Measure output amplitude at the QIF output terminal. Convert the result to $\text{dB}\mu\text{V}$.

(Note 25) Carrier wave rejection ratio

As in Note 9, measure the QIF output terminal carrier wave rejection ratio.

(Note 26) Harmonic rejection ratio

As in Note 10, measure the QIF output terminal secondary harmonic rejection ratio.

(Note 27) Detection output power supply dependence

QIF input : Input the following composite signals to the QIF input.

- (1) $f = 58.75 \text{ MHz}$ $84 \text{ dB}\mu\text{V}$, CW.
- (2) $f = 54.25 \text{ MHz}$ $74 \text{ dB}\mu\text{V}$, CW.

Measure the 4.5 MHz detection output.

Next, measure the detection output when the power supply voltage is $\pm 1 \text{ V}$ of the typ. level. Calculate the ratio.

(Note 28) Input impedance

Connect an impedance analyzer to the QIF input terminal. Measure the input resistance and the input capacitance.

< SIF circuit >

(Note 29) Limiting sensitivity

Limiter input : $f = 4.5 \text{ MHz}$, $f_m = 400 \text{ Hz}$, 25 kHz/devi , $100 \text{ dB}\mu\text{V}$.

Gradually reduce the input signal. Measure the input level when the sound detection output of the sound output terminal will be -3 dB .

(Note 30) Sound detection output

Limiter input : $f = 4.5 \text{ MHz}$, $f_m = 400 \text{ Hz}$, 25 kHz/devi , $100 \text{ dB}\mu\text{V}$.

Measure the sound detection output of the sound output terminal.

(Note 31) Sound S/N ratio

Limiter input : $f = 4.5 \text{ MHz}$, $f_m = 400 \text{ Hz}$, 25 kHz/devi , $100 \text{ dB}\mu\text{V}$.

Measure the sound detection output level of the sound output pin.

Then, measure the sound detection output level without modulation.

$$S/N = 20 \log \left[\frac{\text{Value with modulation (mV}_{\text{rms}})}{\text{Value without modulation (mV}_{\text{rms}})} \right] [\text{dB}]$$

(Note 32) -3 dB bandwidth

Limiter input : $f = 4.5 \text{ MHz}$, $f_m = 400 \text{ Hz}$, 25 kHz/devi , $100 \text{ dB}\mu\text{V}$.

(1) fAFh : Gradually raise the frequency. Measure the input frequency when the sound detection output of the sound output terminal will be -3 dB .

(2) fAFI : Gradually lower the frequency. Measure the input frequency when the sound detection output of the sound output terminal will be -3 dB .

$$-3 \text{ dB bandwidth} = (f\text{AFh} - f\text{AFI}) \quad [\text{kHz}]$$

(Note 33) AM suppression ratio

Limiter input : $f = 4.5 \text{ MHz}$, $100 \text{ dB}\mu\text{V}$.

Measure the sound detection output level of the sound output terminal when the above signals are modulated as follows. Calculate the ratio.

(1) AM modulation : $f_m = 400 \text{ Hz}$, 30%

(2) FM modulation : $f_m = 400 \text{ Hz}$, 25 kHz/devi

$$\text{AMR} = 20 \log \left[\frac{\text{With FM modulation (mV}_{\text{rms}})}{\text{With AM modulation (mV}_{\text{rms}})} \right] [\text{dB}]$$

(Note 34) Distortion ratio

Limiter input : $f = 4.5 \text{ MHz}$, $f_m = 400 \text{ Hz}$, 25 kHz/devi , $100 \text{ dB}\mu\text{V}$.
 Measure the sound output terminal distortion ratio.

(Note 35) Detection output power supply dependence

Limiter input : $f = 4.5 \text{ MHz}$, $f_m = 400 \text{ Hz}$, 25 kHz/devi , $100 \text{ dB}\mu\text{V}$.
 Measure the sound detection output level of the sound output terminal.
 Next, measure the sound detection output when the power supply voltage is $\pm 1 \text{ V}$ of the typ. level. Calculate the ratio.

(Note 36) Input impedance

Connect an impedance analyzer to the limiter input terminal. Measure the input resistance and the input capacitance.

TEST CIRCUIT 1
 DC characteristics

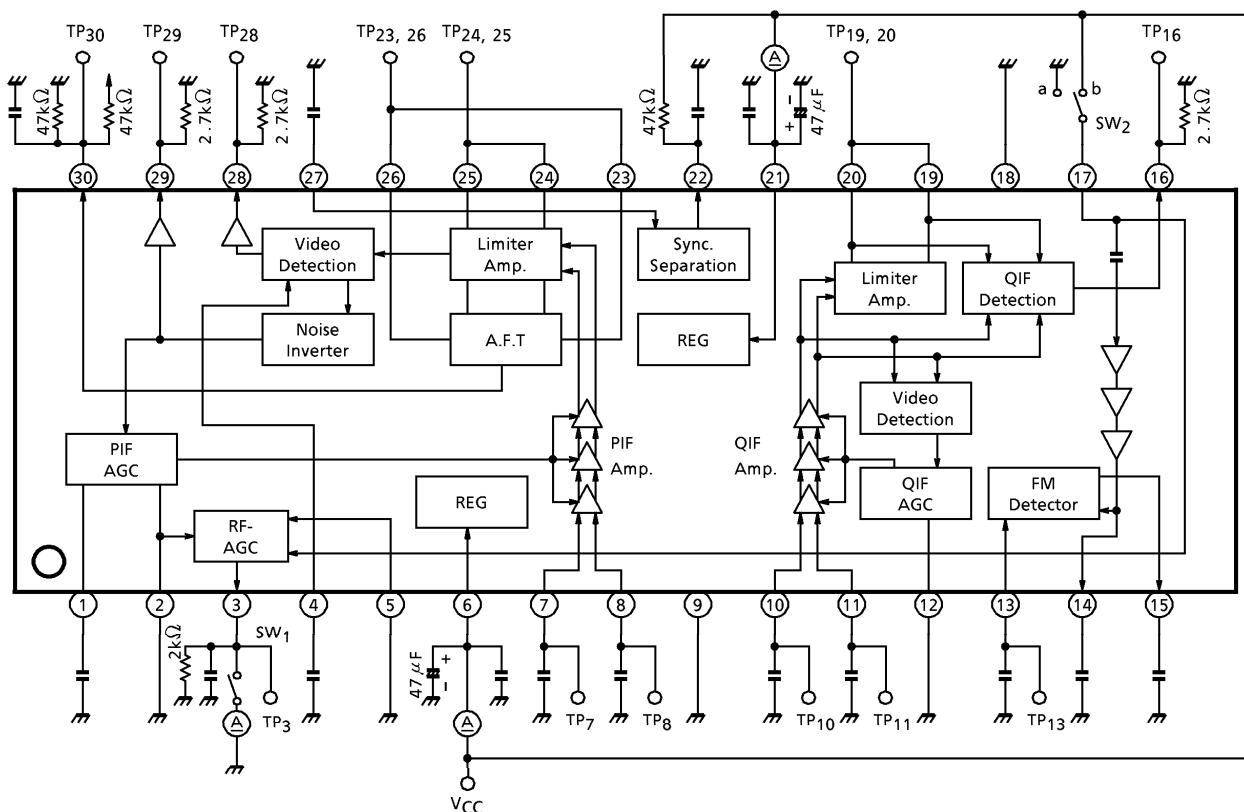

Unless otherwise specified, all capacitors are $0.01 \mu\text{F}$.

TEST CIRCUIT 2
AC characteristics

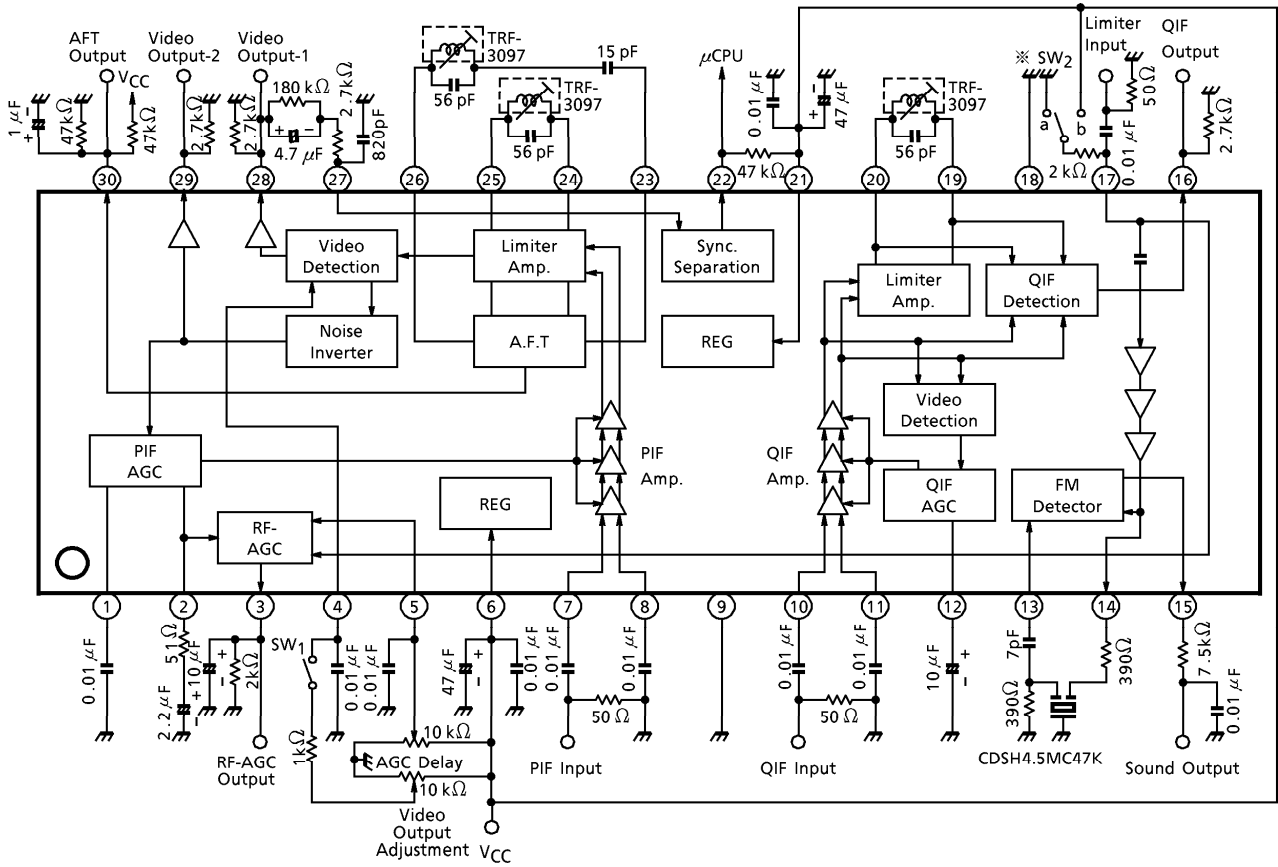

(Note) SW₂ a : Reverse RF AGC
b : Forward RF AGC

EXAMPLE OF APPLICATION CIRCUIT (Reverse RF AGC)

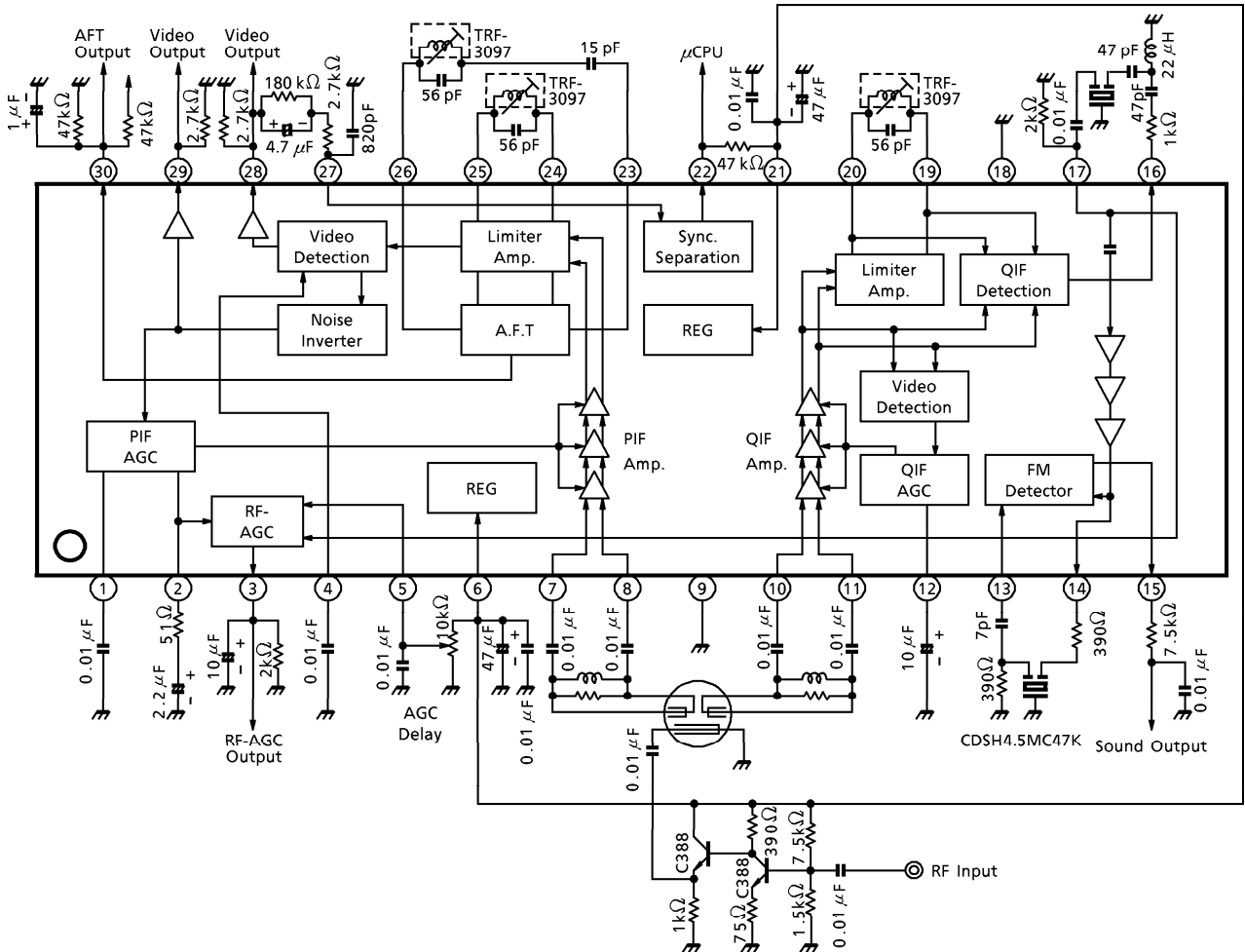

OUTLINE DRAWING
SSOP30-P-375-1.00

Unit : mm

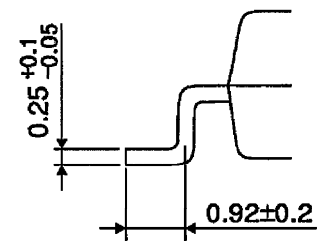
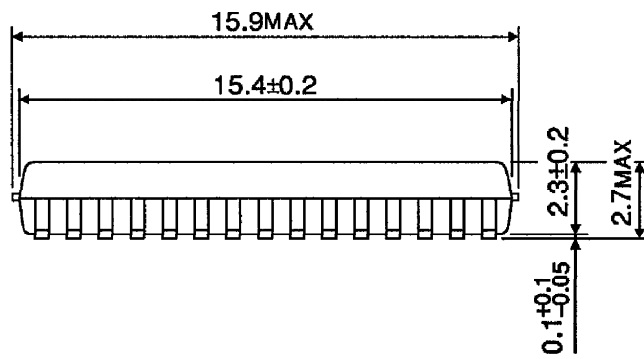
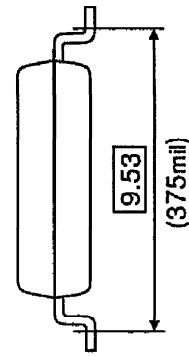
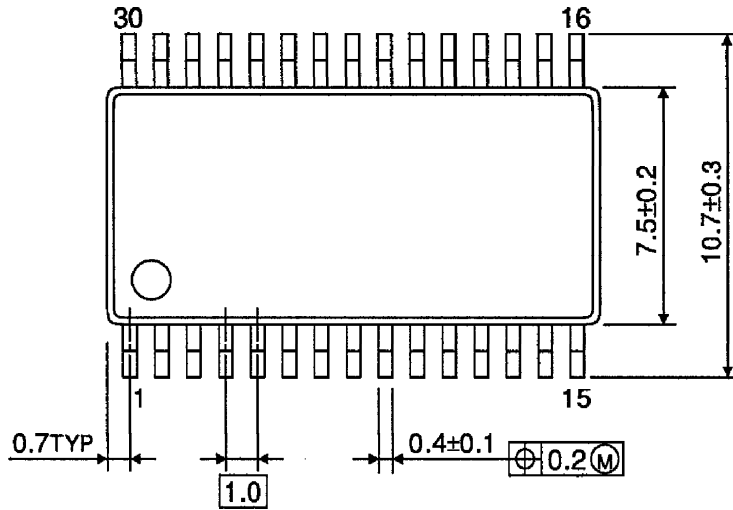

Weight : 0.63 g (Typ.)