

XC6385

Series



PFM (Frequency) Controlled, Step-Up DC/DC Converters

- ◆ **Pager Use** : Low Noise
- ◆ **Duty Ratio** : 75%
- ◆ **CMOS Structure** : Small Supply Current
- ◆ **Operating Voltage Range** : 0.9~10.0V
- ◆ **Output Voltage Range** : 2.0~7.0V
- ◆ **Output Voltage Accuracy** : $\pm 2.5\%$

General Description

The XC6385 series are a group of PFM (frequency) controlled step-up DC/DC converters.

The XC6385 series employs CMOS process and laser trimming technologies to attain low power and high accuracy.

A common problem among pagers is one of noise, but with the XC6385, high frequency noise that occurs during switching is reduced.

Output voltage is selectable in 0.1V steps within 2.0V ~ 7.0V and maximum frequency is 100kHz (Typ.)

With a built-in switching transistor, a step-up circuit can be configured using a coil, diode and capacitor connected externally.

Also available is a CE (chip enable) function that reduces power consumption during shut-down mode, and an independent V_{DD} pin function (separated power supply and voltage detect pins) for fly-back circuits.

SOT-89-5 and SOT-23/25 small packages.

Typical Application Circuit

Electrical Characteristics

For typical application circuit and electrical characteristics of XC6385 series, please refer to that of XC6382 series.

For more detail, please contact Torex sales offices or sales person.

Pin Configuration

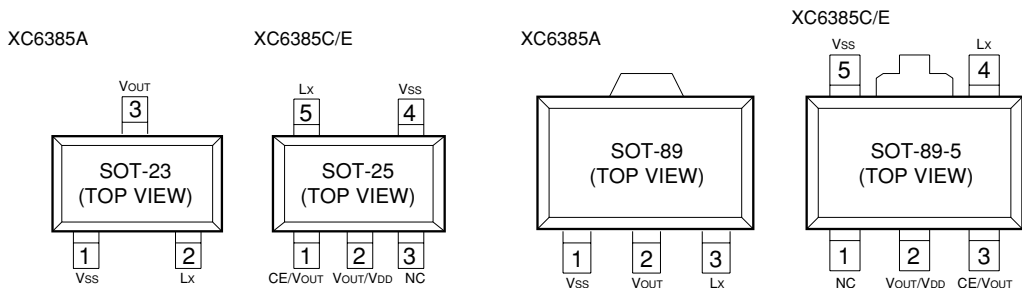

Applications

- Pagers
- Palmtops
- Cameras, Video cameras
- Various portable products

Features

Low noise

Operating voltage range : 0.9V~10V

Output voltage range : 2.0V~7.0V (programmable in 0.1V steps)

Output voltage accuracy : $\pm 2.5\%$

Maximum oscillator frequency : 100kHz ($\pm 15\%$)

Built-in switching transistor

CE function and/or separated V_{DD}/V_{OUT} types selectable with 5 pin packages

Small package : SOT-23/25 mini-mold (3pin, 5pin)
SOT-89/89-5 mini-power mold (3 pin, 5 pin)

Product Classification

Selection Guide

PARAT TYPE	DUTY RATIO	PACKAGE	SWITCHING TRANSISTOR	CE FUNCTION	V _{DD} PIN	FEATURES
XC6385A	75%	SOT-23 SOT-89	Built-in	NO	NO	Duty Ratio 75%
XC6385C	75%	SOT-23 SOT-89-5	Built-in	YES	NO	Stand-by (CE) function During stand-by (CE pin "Low"), Supply current = 0.50μA (max)
XC6385E	75%	SOT-23 SOT-89-5	Built-in	NO	YES	Since the power supply (V _{DD}) pin and the voltage sensor (V _{OUT}) pin are separated, use as a PFM controller is possible.

4

Ordering Information

XC6385①②③④⑤⑥

XC6385 Series PFM Controlled Duty 75%

①	A	3-pin. Built-in switching transistor	
	C	Stand-by capability. (5-pin) Built-in switching transistor	
	E	Stand-by capability. (5-pin) Built-in switching transistor	
② ③	Output Voltage e.g. V _{OUT} =3.5V → ②=3, ③=5		
④	1	Maximum Oscillator Frequency	100kHz
⑤	M	Package	①=A SOT-23 ①=C, E SOT-25
	P	Package	①=A SOT-89 ①=C, E SOT-89-5
⑥	R	Embossed tape: Standard Feed	
	L	Embossed tape: Reverse Feed	

■ Packaging Information

● SOT-23

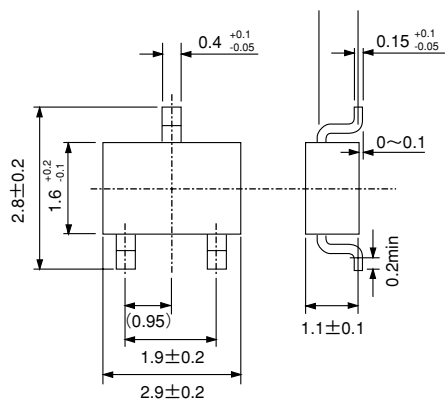

● SOT-25

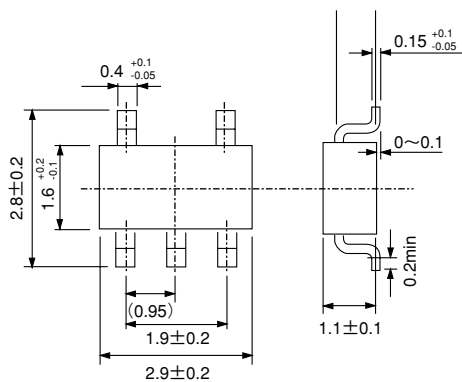

●SOT-89

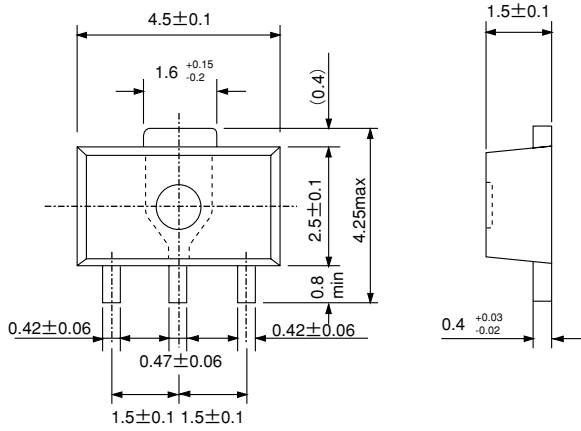

4

●SOT-89-5

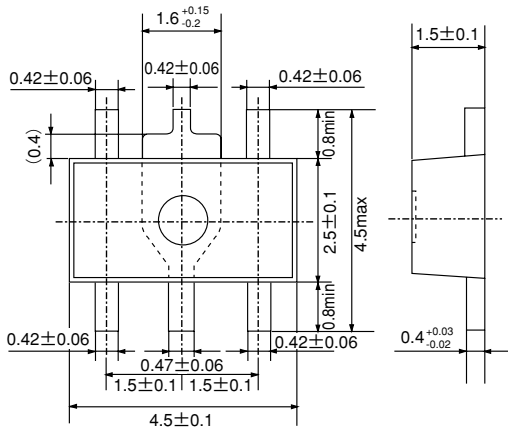

■ Marking

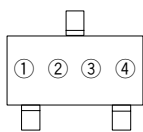

SOT-23
(TOP VIEW)

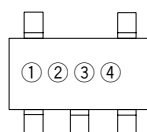

SOT-25
(TOP VIEW)

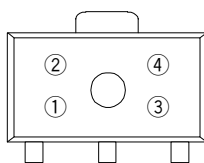

SOT-89
(TOP VIEW)

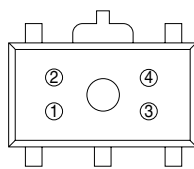

SOT-89-5
(TOP VIEW)

① Represents the Product Classification

DESIGNATOR	FUNCTION	PRODUCT NAME
E	—	Built-in Transistor
L	CE	Built-in Transistor
N	VDD/VIN	Built-in Transistor

② Represents the integer of the Output Voltage and Oscillator Frequency

INTEGER OF THE OUTPUT VOLTAGE	OSCILLATOR FREQUENCY (kHz)
	100
1	1
2	2
3	3
4	4
5	5
6	6
7	7

③ Represents the decimal number of the Output Voltage and Oscillator Frequency

OUTPUT VOLTAGE	OSCILLATOR FREQUENCY (kHz)
	100
0	0
1	1
2	2
3	3
4	4
5	5
6	6
7	7
8	8
9	9

④ Denotes the production lot number
0 to 9, A to Z repeated(G.I.J.O.Q.W excepted)

Block Diagram

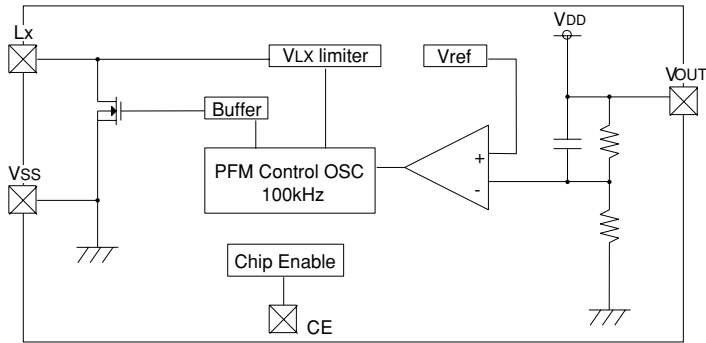

Note: The CE pin is set up for XC6385C.

4

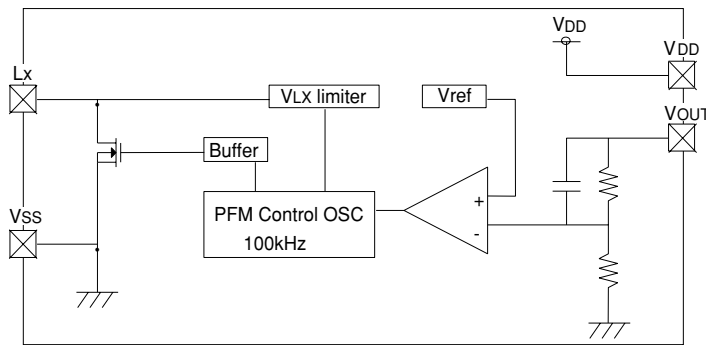

Note: The VDD pin is set up for XC6385E.

Electrical Characteristics

For electrical characteristics of XC6385 series, please refer to that of XC6382 series.

For more detail, please contact Torex sales offices or sales person.

Typical Performance Characteristics

●XC6385A301 (Output Voltage = 3.0V)

(1) OUTPUT VOLTAGE vs. OUTPUT CURRENT (2) EFFICIENCY vs. OUTPUT CURRENT

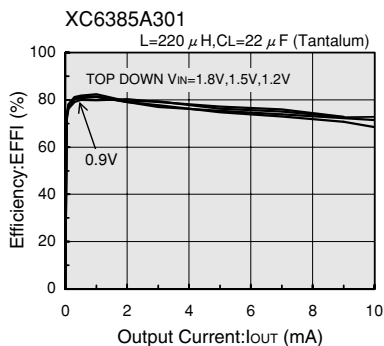
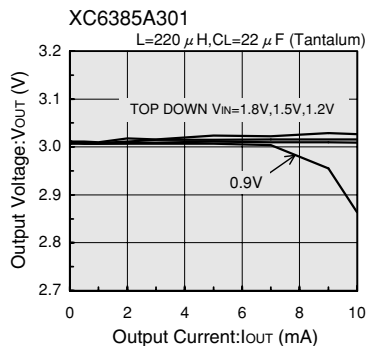

(3) RIPPLE VOLTAGE vs. OUTPUT CURRENT (4) NO LOAD INPUT CURRENT vs. INPUT VOLTAGE

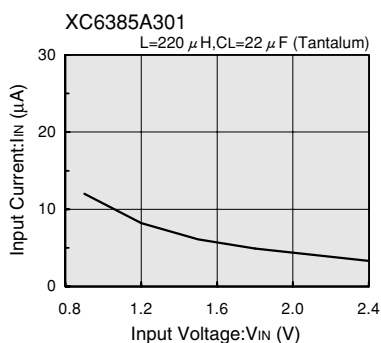
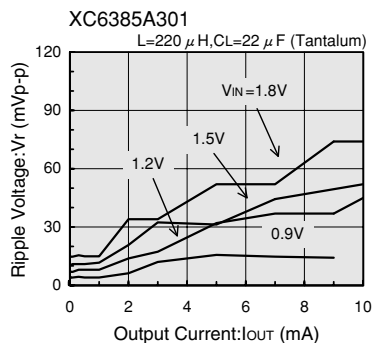

4