

# DATA SHEET

## **CGY2013G** GSM 4 W power amplifier

Preliminary specification  
Supersedes data of 1996 Jul 12  
File under Integrated Circuits, IC17

1998 Jan 23

**GSM 4 W power amplifier****CGY2013G****FEATURES**

- Power Amplifier (PA) overall efficiency 52%
- 35.5 dB gain
- 0 dBm input power
- Gain control range >55 dB
- Low output noise floor of PA < -130 dBm/Hz in GSM RX band
- Wide operating temperature range -20 to +85 °C
- LQFP 48 pin package
- Compatible with power ramping controller PCF5077
- Compatible with GSM RF transceiver SA1620.

**GENERAL DESCRIPTION**

The CGY2013G is a GSM class 4 GaAs Monolithic Microwave Integrated Circuit (MMIC) power amplifier specifically designed to operate at 3.6 V battery supply.

The PA requires only a 30 dB harmonic low-pass filter to comply with the GSM transmit spurious specification. It can be switched off and its power controlled by monitoring the actual drain voltage applied to the amplifier stages.

**APPLICATIONS**

- 880 to 915 MHz hand-held transceivers for E-GSM applications
- 900 MHz Time Division Multiple Access (TDMA) systems.

**QUICK REFERENCE DATA**

SYMBOL	PARAMETER <sup>(1)</sup>	MIN.	TYP.	MAX.	UNIT
V <sub>DD</sub>	positive supply voltage	-	3.6	-	V
I <sub>DD</sub>	positive peak supply current	-	2.4	-	A
P <sub>o(max)</sub>	maximum output power	-	35.5	-	dBm
T <sub>amb</sub>	operating ambient temperature	-20	-	+85	°C

**Note**

1. For conditions, see Chapters "AC characteristics" and "DC characteristics".

**ORDERING INFORMATION**

TYPE NUMBER	PACKAGE		
	NAME	DESCRIPTION	VERSION
CGY2013G	LQFP48	plastic low profile quad flat package; 48 leads; body 7 × 7 × 1.4 mm	SOT313-2

GSM 4 W power amplifier

CGY2013G

BLOCK DIAGRAM

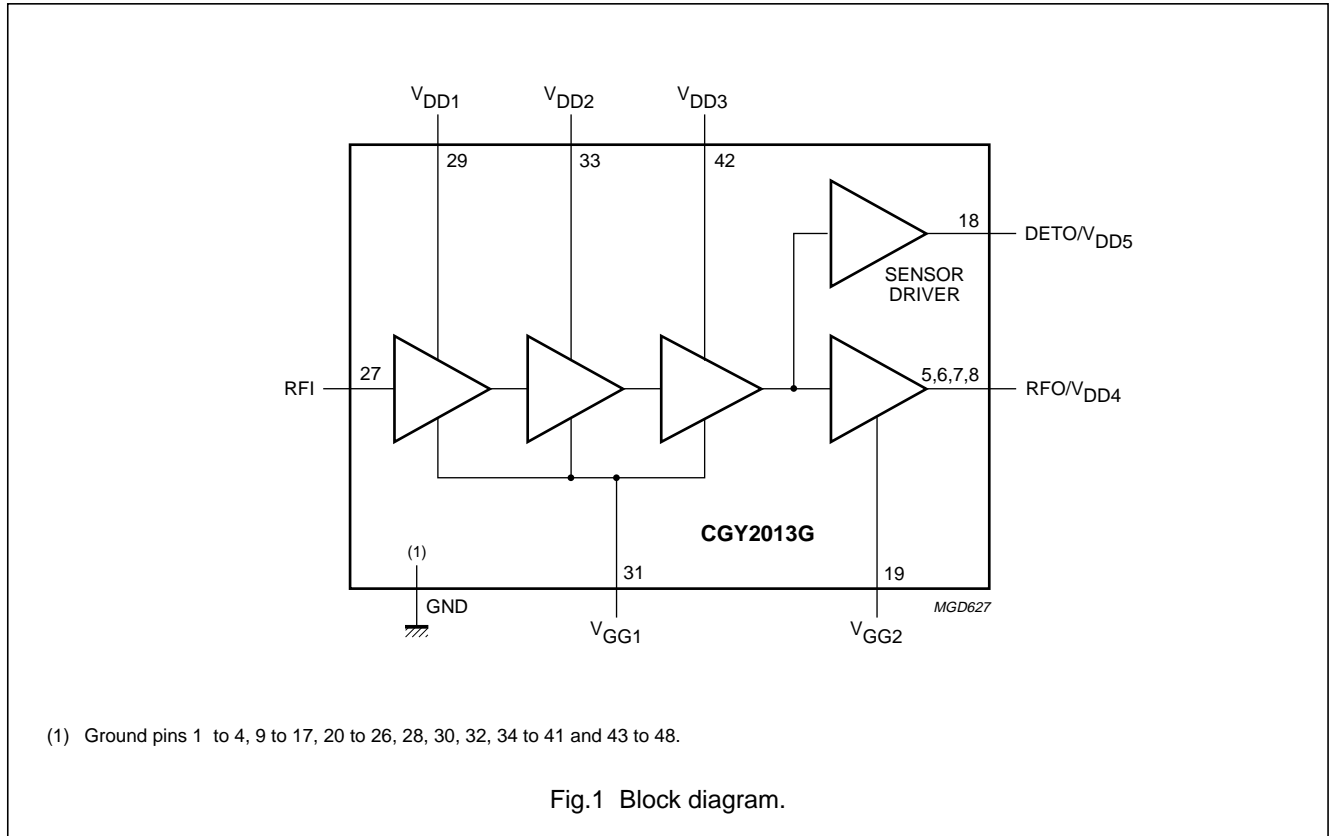

PINNING

SYMBOL	PIN	DESCRIPTION
GND	1 to 4	ground
RFO/V <sub>DD4</sub>	5 to 8	power amplifier output and fourth stage supply voltage
GND	9 to 17	ground
DETO/V <sub>DD5</sub>	18	power sensor output and supply voltage
V <sub>GG2</sub>	19	fourth stage negative gate supply voltage
GND	20 to 26	ground
RFI	27	power amplifier input
GND	28	ground
V <sub>DD1</sub>	29	first stage supply voltage
GND	30	ground
V <sub>GG1</sub>	31	first three stages negative gate supply voltage
GND	32	ground
V <sub>DD2</sub>	33	second stage supply voltage
GND	34 to 41	ground
V <sub>DD3</sub>	42	third stage supply voltage
GND	43 to 48	ground

GSM 4 W power amplifier

CGY2013G

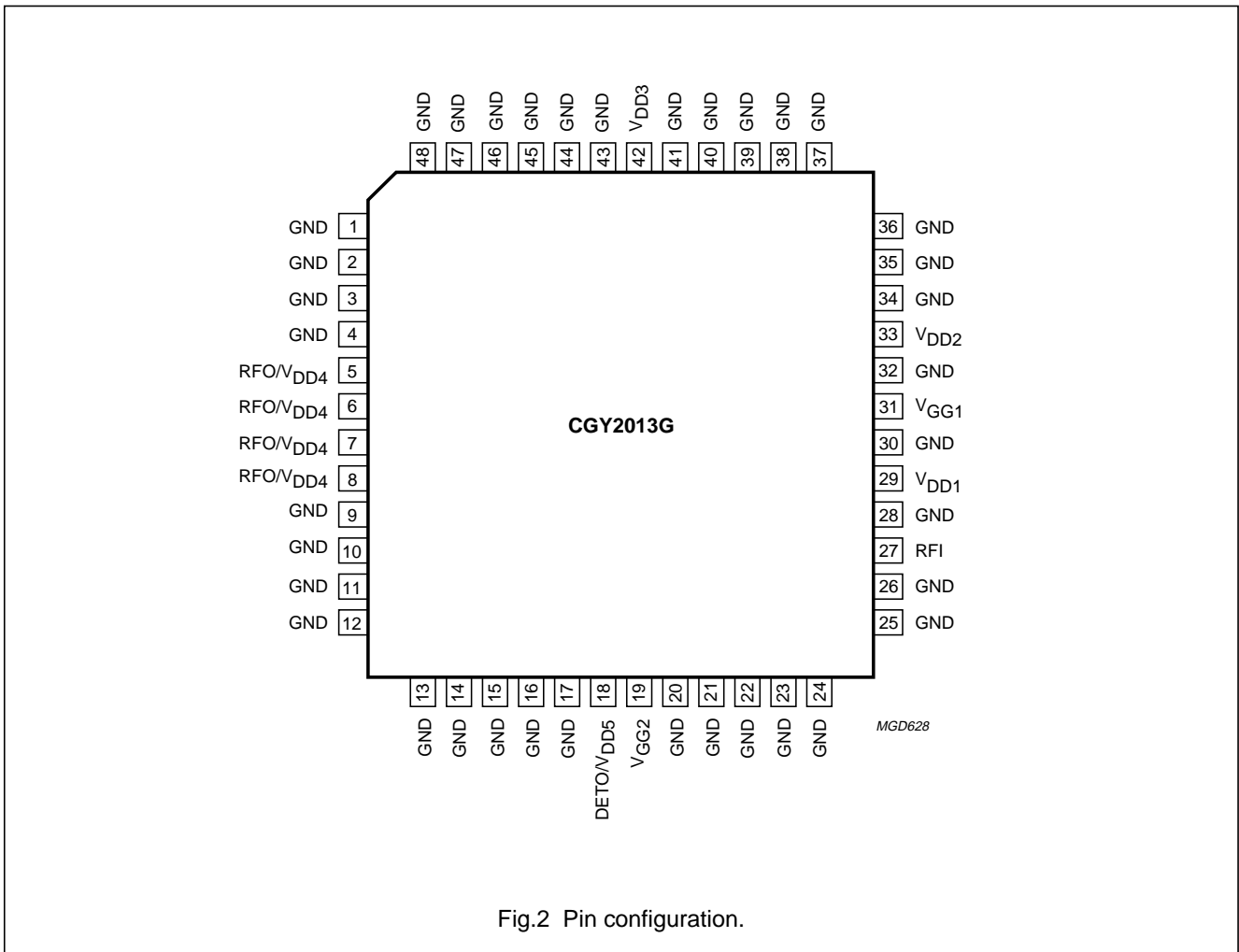

Fig.2 Pin configuration.

**FUNCTIONAL DESCRIPTION**

**Operating conditions**

The CGY2013G is designed to meet the European Telecommunications Standards Institute (ETSI) GSM documents, the "ETS 300 577 specification", which are defined as follows:

- $t_{on} = 542.8 \mu s$
- $T = 4.3 ms$
- Duty cycle = 1/8.

The device is specifically designed for pulse operation allowing the use of a LQFP48 plastic package.

**Power amplifier**

The power amplifier consists of four cascaded gain stages with an open-drain configuration. Each drain has to be loaded externally by an adequate reactive circuit which also has to be a DC path to the supply.

The amplifier bias is set using a negative voltage applied at pins  $V_{GG1}$  and  $V_{GG2}$ . This negative voltage must be present before the supply voltage is applied to the drains to avoid current overstress for the amplifier.

## GSM 4 W power amplifier

CGY2013G

**LIMITING VALUES**

In accordance with the Absolute Maximum Rating System (IEC 134); general operating conditions applied.

SYMBOL	PARAMETER	MIN.	MAX.	UNIT
$V_{DD}$	positive supply voltage	–	7	V
$V_{GG}$	negative supply voltage	–	–10	V
$T_{j(max)}$	maximum operating junction temperature	–	150	°C
$T_{stg}$	IC storage temperature	–	150	°C
$P_{tot}$	total power dissipation	–	1.5	W

**THERMAL CHARACTERISTICS**

General operating conditions applied.

SYMBOL	PARAMETER	VALUE	UNIT
$R_{th\ j-c}$	thermal resistance from junction to case; note 1	25	K/W

**Note**

1. This thermal resistance is measured under GSM pulse conditions.

**DC CHARACTERISTICS**

$V_{DD} = 3.6\text{ V}$ ;  $T_{amb} = 25\text{ °C}$ ; general operating conditions applied; peak current values during burst; unless otherwise specified.

SYMBOL	PARAMETER	CONDITIONS	MIN.	TYP.	MAX.	UNIT
<b>Pins RFO/<math>V_{DD4}</math>, <math>V_{DD3}</math>, <math>V_{DD2}</math>, <math>V_{DD1}</math> and DETO/<math>V_{DD5}</math></b>						
$V_{DD}$	positive supply voltage		0	3.6	5.5	V
$I_{DD}$	positive peak supply current		–	2.4	3.0	A
<b>Pins <math>V_{GG1}</math> and <math>V_{GG2}</math></b>						
$V_{GG1}$	negative supply voltage	note 1	–	–1.8	–	V
$V_{GG2}$	negative supply voltage	note 1	–	–1.8	–	V
$I_{GG1} + I_{GG2}$	negative peak supply current		–	2.5	5	mA

**Note**

1. The negative bias  $V_{GG1}$  and  $V_{GG2}$  must be applied 10  $\mu\text{s}$  before the power amplifier is switched on, and must remain applied until the power amplifier has been switched off.

## GSM 4 W power amplifier

CGY2013G

**AC CHARACTERISTICS**

$V_{DD} = 3.6 \text{ V}$ ;  $T_{amb} = 25 \text{ }^\circ\text{C}$ ;  $V_{GG1} = V_{GG2} = -1.8 \text{ V}$ ; measured on Philips demoboard.

SYMBOL	PARAMETER	CONDITIONS	MIN.	TYP.	MAX.	UNIT
<b>Power amplifier</b>						
$P_i$	input power		-2	-	+2	dBm
$f_{RF}$	RF frequency range		880	-	915	MHz
$P_{o(max)}$	maximum output power	$T_{amb} = 25 \text{ }^\circ\text{C}$ ; $V_{DD} = 3.6 \text{ V}$	33.5	35.5	-	dBm
		$T_{amb} = -20 \text{ to } +85 \text{ }^\circ\text{C}$ ; $V_{DD} = 3 \text{ V}$	32	-	-	dBm
$\eta$	efficiency	$V_{DD} = 3.6 \text{ V}$	42	52	-	%
$P_{o(min)}$	minimum output power	$V_{DD} < 0.1 \text{ V}$	-	-20	-15	dBm
$N_{RX}$	output noise in RX band	$f_{RF} = 925 \text{ to } 935 \text{ MHz}$ at $P_{o(max)}$	-	-	-117	dBm/Hz
		$f_{RF} = 935 \text{ to } 960 \text{ MHz}$ at $P_{o(max)}$	-	-	-125	dBm/Hz
H2	2nd harmonic level		-	-	-35	dBc
H3	3rd harmonic level		-	-	-35	dBc
Stab	stability	note 1	-	-	-70	dBc

**Note**

- The device is adjusted to provide nominal value of load power into a  $50 \text{ } \Omega$  load. The device is switched off and a 6 : 1 load replaces the  $50 \text{ } \Omega$  load. The device is switched on and the phase of the 6 : 1 load is varied 360 electrical degrees during a 60 second period.

GSM 4 W power amplifier

CGY2013G

APPLICATION INFORMATION

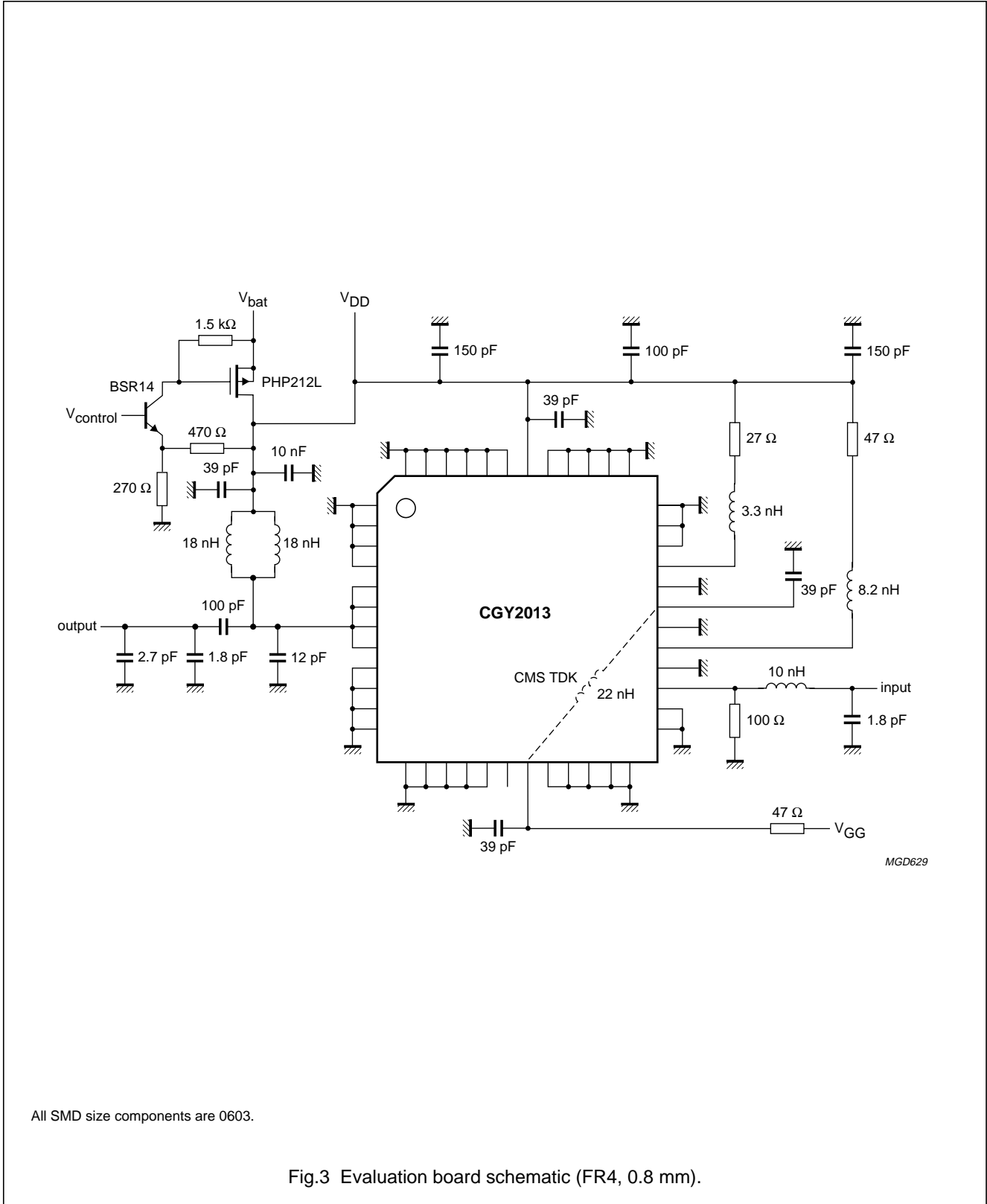

All SMD size components are 0603.

Fig.3 Evaluation board schematic (FR4, 0.8 mm).

GSM 4 W power amplifier

CGY2013G

PACKAGE OUTLINE

LQFP48: plastic low profile quad flat package; 48 leads; body 7 x 7 x 1.4 mm

SOT313-2

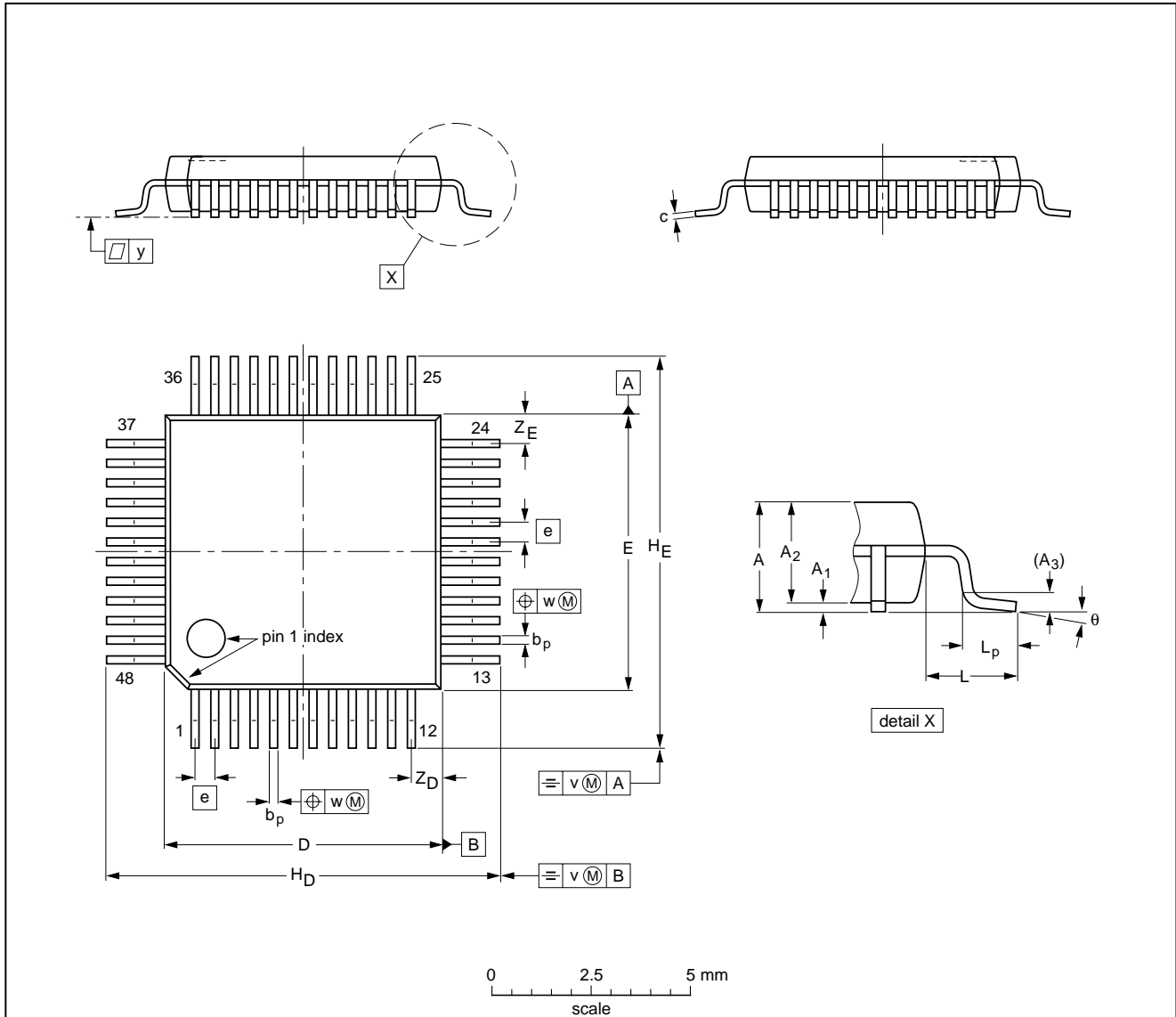

DIMENSIONS (mm are the original dimensions)

UNIT	A max.	A <sub>1</sub>	A <sub>2</sub>	A <sub>3</sub>	b <sub>p</sub>	c	D <sup>(1)</sup>	E <sup>(1)</sup>	e	H <sub>D</sub>	H <sub>E</sub>	L	L <sub>p</sub>	v	w	y	Z <sub>D</sub> <sup>(1)</sup>	Z <sub>E</sub> <sup>(1)</sup>	θ
mm	1.60	0.20 0.05	1.45 1.35	0.25	0.27 0.17	0.18 0.12	7.1 6.9	7.1 6.9	0.5	9.15 8.85	9.15 8.85	1.0	0.75 0.45	0.2	0.12	0.1	0.95 0.55	0.95 0.55	7° 0°

Note

1. Plastic or metal protrusions of 0.25 mm maximum per side are not included.

OUTLINE VERSION	REFERENCES				EUROPEAN PROJECTION	ISSUE DATE
	IEC	JEDEC	EIAJ			
SOT313-2						94-12-19 97-08-01



---

## GSM 4 W power amplifier

CGY2013G

---

### SOLDERING

#### Introduction

There is no soldering method that is ideal for all IC packages. Wave soldering is often preferred when through-hole and surface mounted components are mixed on one printed-circuit board. However, wave soldering is not always suitable for surface mounted ICs, or for printed-circuits with high population densities. In these situations reflow soldering is often used.

This text gives a very brief insight to a complex technology. A more in-depth account of soldering ICs can be found in our *"IC Package Databook"* (order code 9398 652 90011).

#### Reflow soldering

Reflow soldering techniques are suitable for all LQFP packages.

Reflow soldering requires solder paste (a suspension of fine solder particles, flux and binding agent) to be applied to the printed-circuit board by screen printing, stencilling or pressure-syringe dispensing before package placement.

Several techniques exist for reflowing; for example, thermal conduction by heated belt. Dwell times vary between 50 and 300 seconds depending on heating method. Typical reflow temperatures range from 215 to 250 °C.

Preheating is necessary to dry the paste and evaporate the binding agent. Preheating duration: 45 minutes at 45 °C.

#### Wave soldering

Wave soldering is **not** recommended for LQFP packages. This is because of the likelihood of solder bridging due to closely-spaced leads and the possibility of incomplete solder penetration in multi-lead devices.

**If wave soldering cannot be avoided, the following conditions must be observed:**

- **A double-wave (a turbulent wave with high upward pressure followed by a smooth laminar wave) soldering technique should be used.**
- **The footprint must be at an angle of 45° to the board direction and must incorporate solder thieves downstream and at the side corners.**

**Even with these conditions, do not consider wave soldering LQFP packages LQFP48 (SOT313-2), LQFP64 (SOT314-2) or LQFP80 (SOT315-1).**

During placement and before soldering, the package must be fixed with a droplet of adhesive. The adhesive can be applied by screen printing, pin transfer or syringe dispensing. The package can be soldered after the adhesive is cured.

Maximum permissible solder temperature is 260 °C, and maximum duration of package immersion in solder is 10 seconds, if cooled to less than 150 °C within 6 seconds. Typical dwell time is 4 seconds at 250 °C.

A mildly-activated flux will eliminate the need for removal of corrosive residues in most applications.

#### Repairing soldered joints

Fix the component by first soldering two diagonally-opposite end leads. Use only a low voltage soldering iron (less than 24 V) applied to the flat part of the lead. Contact time must be limited to 10 seconds at up to 300 °C. When using a dedicated tool, all other leads can be soldered in one operation within 2 to 5 seconds between 270 and 320 °C.

## GSM 4 W power amplifier

CGY2013G

**DEFINITIONS**

<b>Data sheet status</b>	
Objective specification	This data sheet contains target or goal specifications for product development.
Preliminary specification	This data sheet contains preliminary data; supplementary data may be published later.
Product specification	This data sheet contains final product specifications.
Short-form specification	The data in this specification is extracted from a full data sheet with the same type number and title. For detailed information see the relevant data sheet or data handbook.
<b>Limiting values</b>	
Limiting values given are in accordance with the Absolute Maximum Rating System (IEC 134). Stress above one or more of the limiting values may cause permanent damage to the device. These are stress ratings only and operation of the device at these or at any other conditions above those given in the Characteristics sections of the specification is not implied. Exposure to limiting values for extended periods may affect device reliability.	
<b>Application information</b>	
Where application information is given, it is advisory and does not form part of the specification.	

**LIFE SUPPORT APPLICATIONS**

These products are not designed for use in life support appliances, devices, or systems where malfunction of these products can reasonably be expected to result in personal injury. Philips customers using or selling these products for use in such applications do so at their own risk and agree to fully indemnify Philips for any damages resulting from such improper use or sale.

GSM 4 W power amplifier

CGY2013G

---

NOTES

# Philips Semiconductors – a worldwide company

**Argentina:** see South America

**Australia:** 34 Waterloo Road, NORTH RYDE, NSW 2113, Tel. +61 2 9805 4455, Fax. +61 2 9805 4466

**Austria:** Computerstr. 6, A-1101 WIEN, P.O. Box 213, Tel. +43 1 60 101, Fax. +43 1 60 101 1210

**Belarus:** Hotel Minsk Business Center, Bld. 3, r. 1211, Volodarski Str. 6, 220050 MINSK, Tel. +375 172 200 733, Fax. +375 172 200 773

**Belgium:** see The Netherlands

**Brazil:** see South America

**Bulgaria:** Philips Bulgaria Ltd., Energoproject, 15th floor, 51 James Bourchier Blvd., 1407 SOFIA, Tel. +359 2 689 211, Fax. +359 2 689 102

**Canada:** PHILIPS SEMICONDUCTORS/COMPONENTS, Tel. +1 800 234 7381, Fax. +1 708 296 8556

**China/Hong Kong:** 501 Hong Kong Industrial Technology Centre, 72 Tat Chee Avenue, Kowloon Tong, HONG KONG, Tel. +852 2319 7888, Fax. +852 2319 7700

**Colombia:** see South America

**Czech Republic:** see Austria

**Denmark:** Prags Boulevard 80, PB 1919, DK-2300 COPENHAGEN S, Tel. +45 32 88 2636, Fax. +45 31 57 1949

**Finland:** Sinikalliontie 3, FIN-02630 ESPOO, Tel. +358 615 800, Fax. +358 615 80920

**France:** 4 Rue du Port-aux-Vins, BP317, 92156 SURESNES Cedex, Tel. +33 1 40 99 6161, Fax. +33 1 40 99 6427

**Germany:** Hammerbrookstraße 69, D-20097 HAMBURG, Tel. +49 40 23 52 60, Fax. +49 40 23 536 300

**Greece:** No. 15, 25th March Street, GR 17778 TAVROS, Tel. +30 1 4894 339/911, Fax. +30 1 4814 240

**Hungary:** see Austria

**India:** Philips INDIA Ltd, Shivsagar Estate, A Block, Dr. Annie Besant Rd. Worli, MUMBAI 400 018, Tel. +91 22 4938 541, Fax. +91 22 4938 722

**Indonesia:** see Singapore

**Ireland:** Newstead, Clonskeagh, DUBLIN 14, Tel. +353 1 7640 000, Fax. +353 1 7640 200

**Israel:** RAPAC Electronics, 7 Kehilat Saloniki St, TEL AVIV 61180, Tel. +972 3 645 0444, Fax. +972 3 648 1007

**Italy:** PHILIPS SEMICONDUCTORS, Piazza IV Novembre 3, 20124 MILANO, Tel. +39 2 6752 2531, Fax. +39 2 6752 2557

**Japan:** Philips Bldg 13-37, Kohnan 2-chome, Minato-ku, TOKYO 108, Tel. +81 3 3740 5130, Fax. +81 3 3740 5077

**Korea:** Philips House, 260-199 Itaewon-dong, Yongsan-ku, SEOUL, Tel. +82 2 709 1412, Fax. +82 2 709 1415

**Malaysia:** No. 76 Jalan Universiti, 46200 PETALING JAYA, SELANGOR, Tel. +60 3 750 5214, Fax. +60 3 757 4880

**Mexico:** 5900 Gateway East, Suite 200, EL PASO, TEXAS 79905, Tel. +1 800 234 7381, Fax. +1 708 296 8556

**Middle East:** see Italy

**Netherlands:** Postbus 90050, 5600 PB EINDHOVEN, Bldg. VB, Tel. +31 40 27 83749, Fax. +31 40 27 88399

**New Zealand:** 2 Wagener Place, C.P.O. Box 1041, AUCKLAND, Tel. +64 9 849 4160, Fax. +64 9 849 7811

**Norway:** Box 1, Manglerud 0612, OSLO, Tel. +47 22 74 8000, Fax. +47 22 74 8341

**Philippines:** Philips Semiconductors Philippines Inc., 106 Valero St. Salcedo Village, P.O. Box 2108 MCC, MAKATI, Metro MANILA, Tel. +63 2 816 6380, Fax. +63 2 817 3474

**Poland:** Ul. Lukiska 10, PL 04-123 WARSZAWA, Tel. +48 22 612 2831, Fax. +48 22 612 2327

**Portugal:** see Spain

**Romania:** see Italy

**Russia:** Philips Russia, Ul. Usatcheva 35A, 119048 MOSCOW, Tel. +7 095 926 5361, Fax. +7 095 564 8323

**Singapore:** Lorong 1, Toa Payoh, SINGAPORE 1231, Tel. +65 350 2538, Fax. +65 251 6500

**Slovakia:** see Austria

**Slovenia:** see Italy

**South Africa:** S.A. PHILIPS Pty Ltd., 195-215 Main Road Martindale, 2092 JOHANNESBURG, P.O. Box 7430 Johannesburg 2000, Tel. +27 11 470 5911, Fax. +27 11 470 5494

**South America:** Rua do Rocio 220, 5th floor, Suite 51, 04552-903 São Paulo, SÃO PAULO - SP, Brazil, Tel. +55 11 821 2333, Fax. +55 11 829 1849

**Spain:** Balmes 22, 08007 BARCELONA, Tel. +34 3 301 6312, Fax. +34 3 301 4107

**Sweden:** Kottbygatan 7, Akalla, S-16485 STOCKHOLM, Tel. +46 8 632 2000, Fax. +46 8 632 2745

**Switzerland:** Allmendstrasse 140, CH-8027 ZÜRICH, Tel. +41 1 488 2686, Fax. +41 1 481 7730

**Taiwan:** PHILIPS TAIWAN Ltd., 23-30F, 66, Chung Hsiao West Road, Sec. 1, P.O. Box 22978, TAIPEI 100, Tel. +886 2 382 4443, Fax. +886 2 382 4444

**Thailand:** PHILIPS ELECTRONICS (THAILAND) Ltd., 209/2 Sanpavuth-Bangna Road Prakanong, BANGKOK 10260, Tel. +66 2 745 4090, Fax. +66 2 398 0793

**Turkey:** Talatpasa Cad. No. 5, 80640 GÜLTEPE/ISTANBUL, Tel. +90 212 279 2770, Fax. +90 212 282 6707

**Ukraine:** PHILIPS UKRAINE, 2A Akademika Koroleva str., Office 165, 252148 KIEV, Tel. +380 44 476 0297/1642, Fax. +380 44 476 6991

**United Kingdom:** Philips Semiconductors Ltd., 276 Bath Road, Hayes, MIDDLESEX UB3 5BX, Tel. +44 181 730 5000, Fax. +44 181 754 8421

**United States:** 811 East Arques Avenue, SUNNYVALE, CA 94088-3409, Tel. +1 800 234 7381, Fax. +1 708 296 8556

**Uruguay:** see South America

**Vietnam:** see Singapore

**Yugoslavia:** PHILIPS, Trg N. Pasica 5/v, 11000 BEOGRAD, Tel. +381 11 825 344, Fax. +381 11 635 777

**For all other countries apply to:** Philips Semiconductors, Marketing & Sales Communications, Building BE-p, P.O. Box 218, 5600 MD EINDHOVEN, The Netherlands, Fax. +31 40 27 24825

**Internet:** <http://www.semiconductors.philips.com/ps/>

© Philips Electronics N.V. 1996

SCA50

All rights are reserved. Reproduction in whole or in part is prohibited without the prior written consent of the copyright owner.

The information presented in this document does not form part of any quotation or contract, is believed to be accurate and reliable and may be changed without notice. No liability will be accepted by the publisher for any consequence of its use. Publication thereof does not convey nor imply any license under patent- or other industrial or intellectual property rights.

Printed in The Netherlands

437027/1200/02/pp12

Date of release: 1998 Jan 23

Document order number: 9397 750 03166

*Let's make things better.*

**Philips  
Semiconductors**



**PHILIPS**