



# XC3000A Logic Cell Array Family

## Product Specifications

### Features

- Enhanced, high performance FPGA family with five device types
  - Improved redesign of the basic XC3000 LCA Family
  - Logic densities from 1,000 to 6,000 gates
  - Up to 144 user-definable I/Os
- Superset of the industry-leading XC3000 family
  - Identical to the basic XC3000 in structure, pin out, design methodology, and software tools
  - 100% compatible with all XC3000, XC3000L, and XC3100 bitstreams
  - Improved routing and additional features
- Additional programmable interconnection points (PIPs)
  - Improved access to longlines and CLB clock enable inputs
  - Most efficient XC3000-class solution to bus-oriented designs
- Advanced 0.8  $\mu$  CMOS static memory technology
  - Low quiescent and active power consumption
- Performance specified by logic delays, faster than corresponding XC3000 versions
- XC3000A-specific features
  - 4 mA output sink and source current
  - Error checking of the configuration bitstream
  - Soft startup starts all outputs in slew-limited mode upon power-up
  - Easy migration to the XC3400 series of HardWire mask programmed devices for high-volume production.

### Description

The XC3000A family offers the following enhancements over the popular XC3000 family:

The XC3000A family has additional interconnect resources to drive the I-inputs of TBUFs driving horizontal Longlines. The CLB Clock Enable input can be driven from a second vertical Longline. These two additions result in more efficient and faster designs when horizontal Longlines are used for data bussing.

During configuration, the XC3000A devices check the bitstream format for stop bits in the appropriate positions. Any error terminates the configuration and pulls INIT Low.

When the configuration process is finished and the device starts up in user mode, the first activation of the outputs is automatically slew-rate limited. This feature, called Soft Startup, avoids the potential ground bounce when all outputs are turned on simultaneously. After start-up, the slew rate of the individual outputs is, as in the XC3000 family, determined by the individual configuration option.

The XC3000A family is a superset of the XC3000 family. Any bitstream used to configure an XC3000 or XC3100 device configures an XC3000A device exactly the same way.

Device	CLBs	Array	User I/Os Max	Flip-Flops	Horizontal Longlines	Configurable Data Bits
XC3020A	64	8 x 8	64	256	16	14,779
XC3030A	100	10 x 10	80	360	20	22,176
XC3042A	144	12 x 12	96	480	24	30,784
XC3064A	224	16 x 14	120	688	32	46,064
XC3090A	320	16 x 20	144	928	40	64,160

Xilinx maintains test specifications for each product as controlled documents. To insure the use of the most recently released device performance parameters, please request a copy of the current test-specification revision.

### Absolute Maximum Ratings

Symbol	Description		Units
$V_{CC}$	Supply voltage relative to GND	-0.5 to +7.0	V
$V_{IN}$	Input voltage with respect to GND	-0.5 to $V_{CC} + 0.5$	V
$V_{TS}$	Voltage applied to 3-state output	-0.5 to $V_{CC} + 0.5$	V
$T_{STG}$	Storage temperature (ambient)	-65 to +150	°C
$T_{SOL}$	Maximum soldering temperature (10 s @ 1/16 in.)	+260	°C
$T_J$	Junction temperature plastic	+125	°C
	Junction temperature ceramic	+150	°C

Note: Stresses beyond those listed under Absolute Maximum Ratings may cause permanent damage to the device. These are stress ratings only, and functional operation of the device at these or any other conditions beyond those listed under Recommended Operating Conditions is not implied. Exposure to Absolute Maximum Ratings conditions for extended periods of time may affect device reliability.

### Operating Conditions

Symbol	Description	Min	Max	Units
$V_{CC}$	Supply voltage relative to GND Commercial 0°C to +85°C junction	4.75	5.25	V
	Supply voltage relative to GND Industrial -40°C to +100°C junction	4.5	5.5	V
$V_{IHT}$	High-level input voltage — TTL configuration	2.0	$V_{CC}$	V
$V_{ILT}$	Low-level input voltage — TTL configuration	0	0.8	V
$V_{IHC}$	High-level input voltage — CMOS configuration	70%	100%	$V_{CC}$
$V_{ILC}$	Low-level input voltage — CMOS configuration	0	20%	$V_{CC}$
$T_{IN}$	Input signal transition time		250	ns

At junction temperatures above those listed as Operating Conditions, all delay parameters increase by 0.3% per °C.

## DC Characteristics Over Operating Conditions

Symbol	Description		Min	Max	Units
$V_{OH}$	High-level output voltage (@ $I_{OH} = -4.0$ mA, $V_{CC}$ min)	Commercial	3.86		V
$V_{OL}$	Low-level output voltage (@ $I_{OL} = 4.0$ mA, $V_{CC}$ min)			0.40	V
$V_{OH}$	High-level output voltage (@ $I_{OH} = -4.0$ mA, $V_{CC}$ min)	Industrial	3.76		V
$V_{OL}$	Low-level output voltage (@ $I_{OL} = 4.0$ mA, $V_{CC}$ min)			0.40	V
$V_{CCPD}$	Power-down supply voltage (PWRDWN must be Low)		2.30		V
$I_{CCPD}$	Power-down supply current ( $V_{CC(MAX)}$ @ $T_{MAX}$ )			50	$\mu$ A
$I_{CCO}$	Quiescent LCA supply current in addition to $I_{CCPD}$ * Chip thresholds programmed as CMOS levels			500	$\mu$ A
	Chip thresholds programmed as TTL levels			10	mA
$I_{IL}$	Input Leakage Current		-10	+10	$\mu$ A
$C_{IN}$	Input capacitance, all packages except PGA175 (sample tested) All Pins except XTL1 and XTL2 XTL1 and XTL2			10 15	pF pF
	Input capacitance, PGA 175 (sample tested) All Pins except XTL1 and XTL2 XTL1 and XTL2			15 20	pF pF
$I_{RIN}$	Pad pull-up (when selected) @ $V_{IN} = 0$ V (sample tested)		0.02	0.17	mA
$I_{RLL}$	Horizontal Longline pull-up (when selected) @ logic Low			3.4	mA

\* With no output current loads, no active input or Longline pull-up resistors, all package pins at  $V_{CC}$  or GND, and the LCA device configured with a MakeBits tie option.

### CLB Switching Characteristic Guidelines

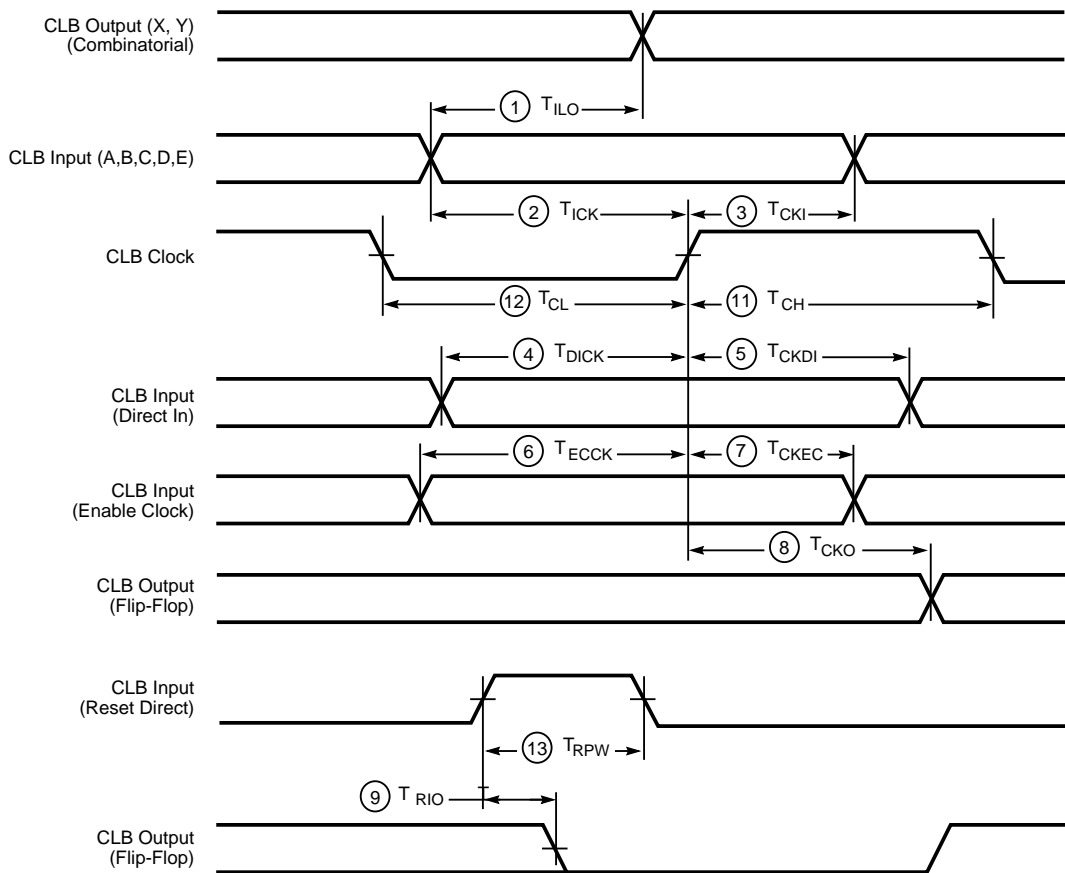

X5424

### Buffer (Internal) Switching Characteristic Guidelines

		Speed Grade	-7	-6	
Description	Symbol	Max	Max		Units
<b>Global and Alternate Clock Distribution*</b> Either: <b>Normal</b> IOB input pad through clock buffer to any CLB or IOB clock input Or: <b>Fast</b> (CMOS only) input pad through clock buffer to any CLB or IOB clock input	$T_{PID}$	7.5	7.0		ns
	$T_{PIDC}$	6.0	5.7		ns
<b>TBUF</b> driving a Horizontal Longline (L.L.)* I to L.L. while T is Low (buffer active) $T_{\downarrow}$ to L.L. active and valid with single pull-up resistor $T_{\downarrow}$ to L.L. active and valid with pair of pull-up resistors $T_{\uparrow}$ to L.L. High with single pull-up resistor $T_{\uparrow}$ to L.L. High with pair of pull-up resistors	$T_{IO}$	4.5	4.0		ns
	$T_{ON}$	9.0	8.0		ns
	$T_{ON}$	11.0	10.0		ns
	$T_{PUS}$	16.0	14.0		ns
	$T_{PUF}$	10.0	8.0		ns
<b>BIDI</b> Bidirectional buffer delay	$T_{BIDI}$	1.7	1.5		ns

\* Timing is based on the XC3042A, for other devices see XACT timing calculator.

## CLB Switching Characteristic Guidelines (continued)

Testing of the switching parameters is modeled after testing methods specified by MIL-M-38510/605. All devices are 100% functionally tested. Since many internal timing parameters cannot be measured directly, they are derived from benchmark timing patterns. The following guidelines reflect worst-case values over the recommended operating conditions. For more detailed, more precise, and more up-to-date timing information, use the values provided by the XACT timing calculator and used in the simulator.

Description	Speed Grade		-7		-6		Units
	Symbol		Min	Max	Min	Max	
Combinatorial Delay Logic Variables A, B, C, D, E, to outputs X or Y FG Mode F and FGM Mode	1	$T_{ILO}$		5.1 5.6		4.1 4.6	ns ns
Sequential delay Clock k to outputs X or Y Clock k to outputs X or Y when Q is returned through function generators F or G to drive X or Y FG Mode F and FGM Mode	8	$T_{CKO}$		4.5		4.0	ns
		$T_{QLO}$		9.5 10.0		8.0 8.5	ns ns
Set-up time before clock K Logic Variables A, B, C, D, E FG Mode F and FGM Mode Data In DI Enable Clock EC	2 4 6	$T_{ICK}$ $T_{DICK}$ $T_{ECCK}$		4.5 5.0 4.0 4.5		3.5 4.0 3.0 4.0	ns ns ns ns
Hold Time after clock K Logic Variables A, B, C, D, E Data In DI Enable Clock EC	3 5 7	$T_{CKI}$ $T_{CKDI}$ $T_{CKEC}$		0 1.0 2.0		0 1.0 2.0	ns ns ns
Clock Clock High time Clock Low time Max. flip-flop toggle rate	11 12	$T_{CH}$ $T_{CL}$ $F_{CLK}$		4.0 4.0 113.0		3.5 3.5 135.0	ns ns MHz
Reset Direct (RD) RD width delay from RD to outputs X or Y	13 9	$T_{RPW}$ $T_{RIO}$		6.0 6.0		5.0 5.0	ns ns
Global Reset ( <u>RESET</u> Pad)* <u>RESET</u> width (Low) delay from <u>RESET</u> pad to outputs X or Y		$T_{MRW}$ $T_{MRQ}$		16.0 19.0		14.0 17.0	ns ns

\*Timing is based on the XC3042A, for other devices see XACT timing calculator.

Notes: The CLB K to Q output delay ( $T_{CKO}$ , #8) of any CLB, plus the shortest possible interconnect delay, is always longer than the Data In hold time requirement ( $T_{CKDI}$ , #5) of any CLB on the same die.

### I/O Switching Characteristic Guidelines

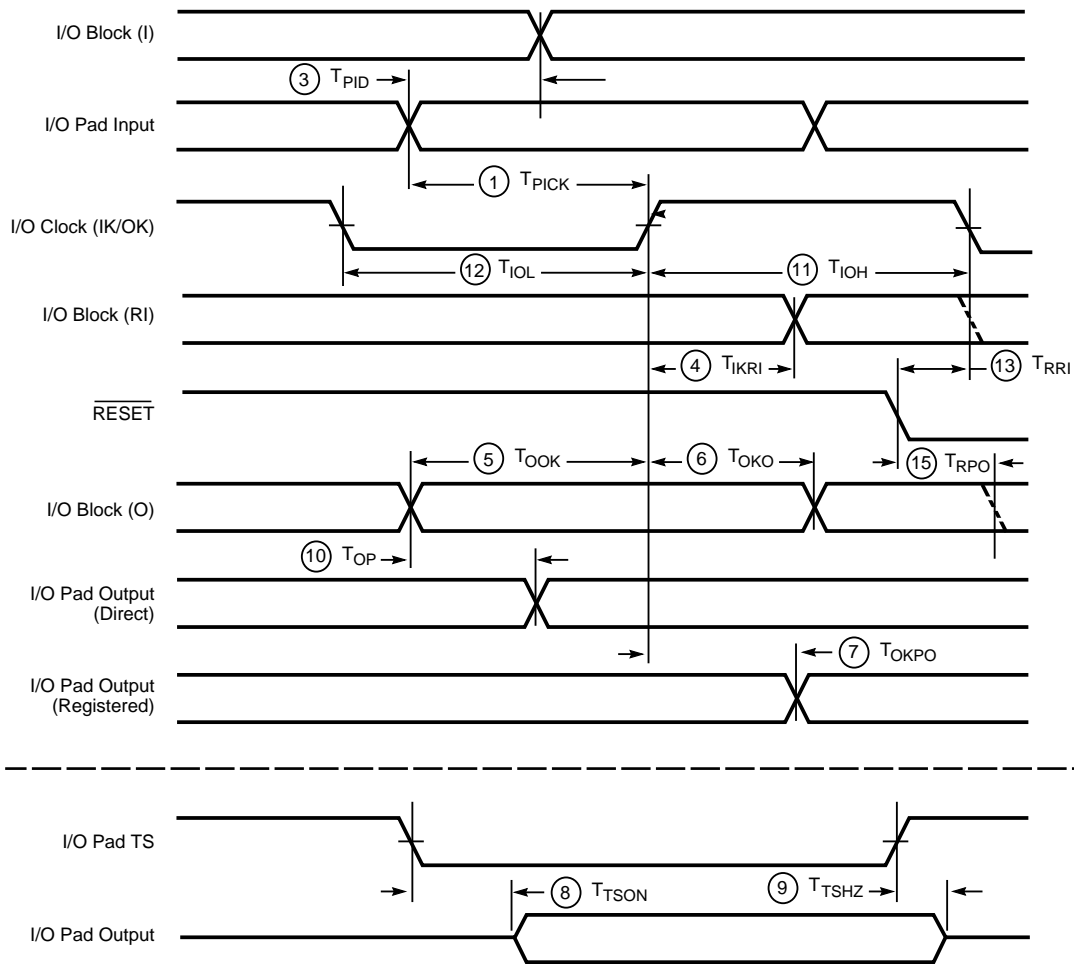

X5425

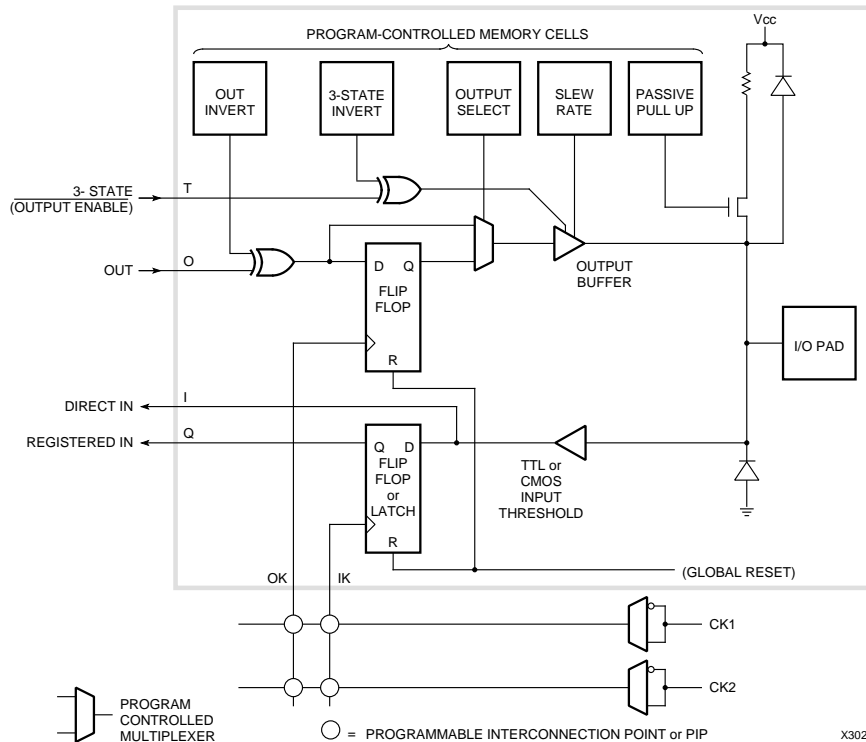

X3029

## IOB Switching Characteristic Guidelines (continued)

Testing of the switching parameters is modeled after testing methods specified by MIL-M-38510/605. All devices are 100% functionally tested. Since many internal timing parameters cannot be measured directly, they are derived from benchmark timing patterns. The following guidelines reflect worst-case values over the recommended operating conditions. For more detailed, more precise, and more up-to-date timing information, use the values provided by the XACT timing calculator and used in the simulator.

Description	Speed Grade		-7		-6		Units
	Symbol	Min	Max	Min	Max		
Propagation Delays (Input)							
Pad to Direct In (I)	3	$T_{PID}$		4.0		3.0	ns
Pad to Registered In (Q) with latch transparent		$T_{PTG}$		15.0		14.0	ns
Clock (IK) to Registered In (Q)	4	$T_{IKRI}$		3.0		2.5	ns
Set-up Time (Input)							
Pad to Clock (IK) set-up time	1	$T_{PICK}$	14.0		12.0		ns
Propagation Delays (Output)							
Clock (OK) to Pad (fast)	7	$T_{OKPO}$		8.0		7.0	ns
same (slew rate limited)	7	$T_{OKPO}$		18.0		15.0	ns
Output (O) to Pad (fast)	10	$T_{OPF}$		6.0		5.0	ns
same (slew-rate limited)	10	$T_{OPS}$		16.0		13.0	ns
3-state to Pad begin hi-Z (fast)	9	$T_{TSHZ}$		10.0		9.0	ns
same (slew-rate limited)	9	$T_{TSHZ}$		20.0		12.0	ns
3-state to Pad active and valid (fast)	8	$T_{TSON}$		11.0		10.0	ns
same (slew -rate limited)	8	$T_{TSON}$		21.0		18.0	ns
Set-up and Hold Times (Output)							
Output (O) to clock (OK) set-up time	5	$T_{OOK}$	8.0		7.0		ns
Output (O) to clock (OK) hold time	6	$T_{OKO}$	0		0		ns
Clock							
Clock High time	11	$T_{IOH}$	4.0		3.5		ns
Clock Low time	12	$T_{IOL}$	4.0		3.5		ns
Max. flip-flop toggle rate		$F_{CLK}$	113.0		135.0		MHz
Global Reset Delays (based on XC3042A)							
RESET Pad to Registered In (Q)	13	$T_{RRI}$		24.0		23.0	ns
RESET Pad to output pad (fast)	15	$T_{RPO}$		33.0		29.0	ns
(slew-rate limited)	15	$T_{RPO}$		43.0		37.0	ns

- Notes:
1. Timing is measured at pin threshold, with 50 pF external capacitive loads (incl. test fixture). For larger capacitive loads, see page XAPP024. Typical slew rate limited output rise/fall times are approximately four times longer.
  2. Voltage levels of unused (bonded and unbonded) pads must be valid logic levels. Each can be configured with the internal pull-up resistor or alternatively configured as a driven output or driven from an external source.
  3. Input pad set-up time is specified with respect to the internal clock (IK). In order to calculate system set-up time, subtract clock delay (pad to IK) from the input pad set-up time value. Input pad holdtime with respect to the internal clock (IK) is negative. This means that pad level changes immediately before the internal clock edge (IK) will not be recognized.
  4.  $T_{PID}$ ,  $T_{PTG}$ , and  $T_{PICK}$  are 3 ns higher for XTL2 when the pin is configured as a user input.

## XC3000A Logic Cell Array Family

For a detailed description of the device architecture, see pages 2-105 through 2-123.

For a detailed description of the configuration modes and their timing, see pages 2-124 through 2-132.

For detailed lists of package pin-outs, see pages 2-140 through 2-150.

For package physical dimensions and thermal data, see Section 4.

### Ordering Information

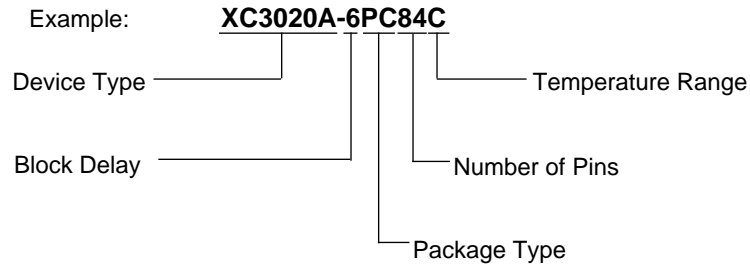

### Component Availability

PINS	44	64	68	84		100				132		144	160	164	175		176	208	223	
TYPE	PLAST. PLCC	PLAST. VQFP	PLAST. PLCC	PLAST. PLCC	CERAM. PGA	PLAST. PQFP	PLAST. TQFP	PLAST. VQFP	TOP-BRAZED CQFP	PLAST. PGA	CERAM. PGA	PLAST. TQFP	PLAST. PQFP	TOP-BRAZED CQFP	PLAST. PGA	CERAM. PGA	PLAST. TQFP	PLAST. PQFP	CERAM. PGA	
CODE	PC44	VQ64	PC68	PC84	PG84	PQ100	TQ100	VQ100	CB100	PP132	PG132	TQ144	PQ160	CB164	PP175	PG175	TQ176	PQ208	PG223	
XC3020A			C I	C I	C I	C I														
			C	C	C	C														
XC3030A	C I	C I	C I	C I	C I	C I		C I												
	C	C	C	C	C	C		C												
XC3042A				C I	C I	C I		C I		C I	C I	C I								
				C	C	C		C		C	C	C								
XC3064A				C I						C I	C I	C I	C I							
				C						C	C	C	C							
XC3090A				C I									C I		C I	C I	C I	C I		
				C									C		C	C	C	C		

C = Commercial = 0° to +85° C

I = Industrial = -40° to +100° C

M = Mil Temp = -55° to +125° C

B = MIL-STD-883C Class B