

Dolby Pro Logic Surround Decoder with Discrete 5.1ch Input

■ GENERAL DESCRIPTION

The **NJW1107** is a Dolby Pro Logic Surround Decoder with discrete 5.1ch input. It includes Dolby Pro Logic Surround decoder, 4 master volumes, 4 level trimmers and 6 switches.

The 6 switches choose internal Dolby Pro Logic Surround Decoder or discrete 5.1ch inputs. The **NJW1107** is most suitable for AV amplifier with discrete 5.1ch inputs for Dolby Digital.

In addition to Dolby Pro Logic Surround function, the **NJW1107** performs easily other surround function such as Hall, Live, Disco and others, and echo and microphone mixing functions for Karaoke.

■ PACKAGE OUTLINE

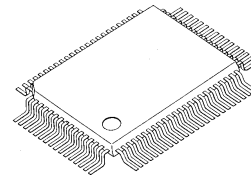

NJW1107FC3

Dolby and double-D symbol are trademarks of Dolby Laboratories Licensing Corporation. San Francisco, CA94103-4813.USA.
 This device is available only to licensees of Dolby Lab.
 Licensing and application information may be obtained from Dolby Lab.

■ FEATURES

- Operating Voltage: $V_{CC}=9V$ (Analog Block), $V_{DD}=5V$ (Digital Block)
- Digital Delay on chip
- Discrete 5.1ch Input for Dolby Digital
- Master Volume for Center, Surround and Subwoofer Channel: -79 to 0dB/1dB step (0dB = Dolby Level)
- Level Trimmer for Center, Surround and Subwoofer Channel: -31 to 0dB/1dB step (0dB = Dolby Level)
- Karaoke function (Echo, MIC mixing)
- Serial Data Interface (3-wire) DATA, REQ, SCK
- Bi-CMOS Technology
- Package Outline QFP80

■ FUNCTION

[Dolby Pro Logic Surround]

- Automatic input balance
- Noise sequencer
- Adaptive matrix
- Center mode control (Wide, Normal, Phantom, Off)
- Modified B-type noise reduction
- 7kHz low pass filter
- Dolby 3 stereo mode
- Digital time delay (15.4, 20.5, 25.6, 29.2ms)

[Other Surround]

- Sound field control
- Front mixing control
- Digital time delay (15.4, 20.5, 25.6, 29.2, 51.2ms)

[Karaoke]

- Echo control
- MIC mixing
- Digital time delay (123, 184ms)

■ SYSTEM BLOCK DIAGRAM

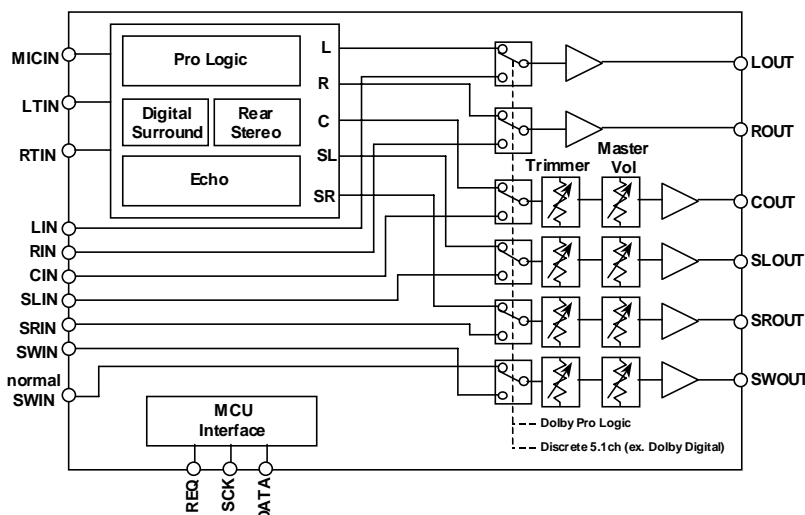

NJW1107

■ PIN CONNECTION

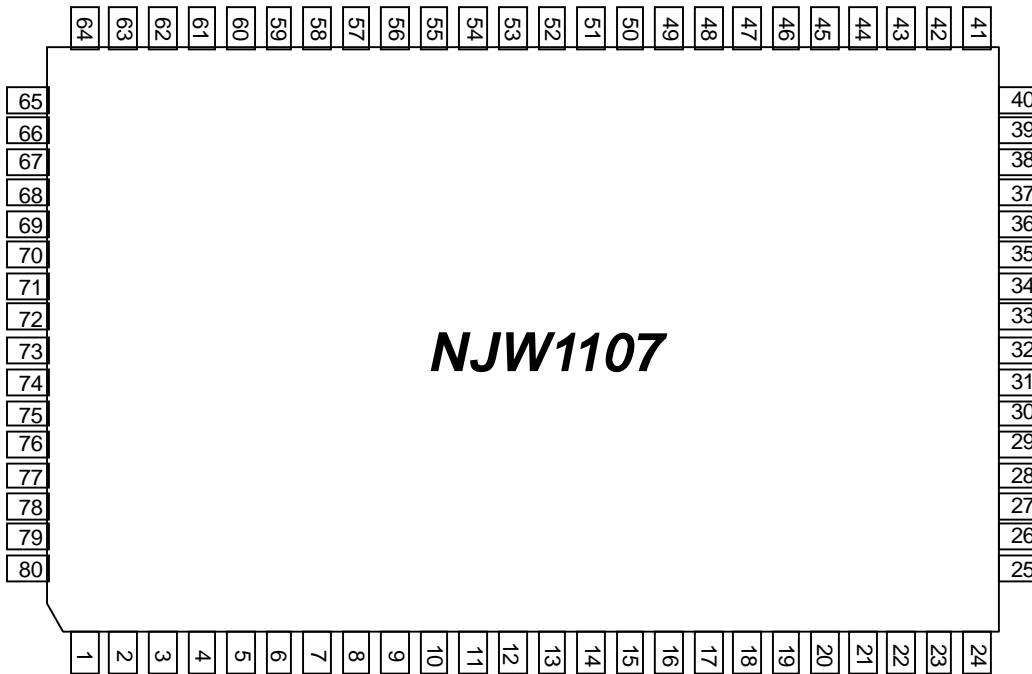

Pin No.	Pin Name	Pin No.	Pin Name	Pin No.	Pin Name	Pin No.	Pin Name
1	LOUT	21	DV _{DD}	41	ECHOOOUT	61	LBPF1
2	ROUT	22	DATA	42	BNRIN	62	RBPF2
3	CVOLOUT	23	SCK	43	DBC1	63	RBPF1
4	CVOLIN	24	REQ	44	DBC2	64	ABL
5	COUT	25	DV _{SS}	45	DBC3	65	ABR
6	SOUT	26	DSELOUT	46	PSC3	66	NGC3
7	PSLIN	27	DIN	47	PSC6	67	NGC2
8	PSRIN	28	LPF1IN1	48	PSC2	68	NGC1
9	SLVOLOUT	29	LPF1IN2	49	PSC5	69	AV _{CC}
10	SLVOLIN	30	LPF1OUT	50	PSC1	70	VREF1
11	SLOUT	31	ADINTIN	51	PSC4	71	REF
12	SROUT	32	ADINTOUT	52	RLC5	72	LIN
13	SRVOLIN	33	ADCONT	53	RLC2	73	RIN
14	SRVOLOUT	34	DACONT	54	RLC1	74	LTIN
15	SWOUT	35	DAINTIN	55	RLC4	75	RTIN
16	SWVOLIN	36	DAINTOUT	56	RLC7	76	CIN
17	SWVOLOUT	37	LPF2IN1	57	RLC3	77	SLIN
18	CMC	38	LPF2IN2	58	RLC8	78	SRIN
19	AGND	39	LPF2OUT	59	RLC6	79	SWIN
20	MICIN	40	DVOLOUT	60	LBPF2	80	VRSWIN

■ ABSOLUTE MAXIMUM RATING (Ta=25°C)

PARAMETER	SYMBOL	RATING	UNIT
Supply Voltage	V _{CC}	10.5	V
	V _{DD}	6.5	V
Power Dissipation	P _D	1.4*	W
Operating Temperature Range	T _{opr}	-20 to +75	°C
Storage Temperature Range	T _{stg}	-40 to +125	°C

*On board

■ ELECTRICAL CHARACTERISTICS (V_{CC}=9V, V_{DD}=5V, Ta=25°C, 0dBd=300mVrms, f=1kHz)

PARAMETER	SYMBOL	TEST CONDITION	MIN.	TYP.	MAX.	UNIT
◆ OVERALL						
Supply Voltage Range	V _{CC}		8	9	10	V
	V _{DD}		4.75	5	5.5	V
Supply Current	I _{CC}	No Signal	-	30	45	mA
	I _{DD}	No Signal	-	15	25	mA
Reference Voltage	V _{REF}	No Signal	-	4.5	-	V
Threshold Voltage	V _{thh}	Digital input high level	2.2	-	V _{DD}	V
	V _{thl}	Digital input low level	0	-	0.8	V
◆ INPUT AUTO BALANCE						
Capture Range	CPR		-	5	-	dB
Error Correction	CER		-	4	-	dB
◆ ADAPTIVE MATRIX						
Output Level	ΔVol	L, R, LSch out	-0.5	0	0.5	dB
Accuracy relative to Cch						
Matrix Rejection relative	MR	L, R, C, LSch out	25	40	-	dB
Headroom	HR-AM	THD=1%	15	17	-	dB
Total Harmonic Distortion	THD-AM	4ch.mode, 30kHz LPF	-	0.05	0.2	%
Signal to Noise Ratio	SNAM	Rg=0, wt: CCIR/ARM, 4ch.mode	70	80	-	dB
◆ NOISE SEQUENCER						
Output Noise Level	Vno	L, R, C, LSch out	-15	-12.5	-10	dB
Output Noise Level	ΔVno	L, R, LSch out	-0.5	0	0.5	dB
Accuracy relative to Cch						
◆ MODIFIED B-TYPE NOISE REDUCTION (0dBd=300mVrms, f=100Hz at LSch out)						
Voltage Gain	GV-NR	Vin=0dBd, f=100Hz	3.8	6.8	9.8	dB
Decode Responce1	DEC1	Vin=0dBd, f=1kHz	-1.6	-0.1	1.4	dB
Decode Responce2	DEC2	Vin=-15dBd, f=1.4kHz	-3.0	-1.5	0	dB
Decode Responce3	DEC3	Vin=-40dBd, f=5kHz	-6.8	-5.3	-3.8	dB
Total Harmonic Distortion	THDNR	Vin=0dBd, f=1kHz, 30kHz LPF	-	0.07	0.3	%
Headroom	HRNR	THD=1%	15	17	-	dB
Signal to Noise Ratio	SNNR	Rg=0, wt CCIR/ARM	68	78	-	dB
◆ Master Volume						
Maximum attenuation	ATT _{max}	ATT=-∞, Vi=2Vrms	-	-95	-87	dB
Minimum attenuation	ATT _{min}	ATT=0, TRIM=0dB	-3.0	0	3.0	dB
Volume Step1	VOLS1	ATT=0 to -40dB, TRIM=0dB	0.5	1.0	1.5	dB
Volume Step2	VOLS2	ATT=-40 to -79dB, TRIM=0dB	0.2	1.0	1.8	dB
Signal to Noise Ratio	SNVOL	ATT=-∞, CCIR/ARM	85	95	-	dB

■ ELECTRICAL CHARACTERISTICS ($V_{CC}=9V$, $V_{DD}=5V$, $T_a=25^{\circ}C$, $0dBd=300mV_{rms}$, $f=1kHz$)

PARAMETER	SYMBOL	TEST CONDITION	MIN.	TYP.	MAX.	UNIT
◆ Trimmer						
Maximum attenuation	$TRIM_{max}$	TRIM=-31dB, VOLATT=0dB	-34	-31	-28	dB
Minimum attenuation	$TRIM_{min}$	TRIM=0dB, VOLATT=0dB	-3.0	0	3.0	dB
Trimmer Step	TRIMS	VOLATT=0dB	0.6	1.0	1.4	dB
◆ Line						
Total Harmonic Distortion	THDLN	30kHz LPF	-	0.002	0.05	%
Signal to Noise Ratio	SNLN	DIN-AUDIO	95	100	-	dB
Line Cross-talk	CTLN		70	80	-	dB
Input Impedance	Z_i		11	22	44	k Ω
◆ DIGITAL TIME DELAY						
Delay Time	T_d	$T_d=20.5ms$	17.4	20.5	23.6	ms
Total Gain	G_vD	DIN-DVOLOUT, DDVOL=0dB	-3.0	0	3.0	dB
Total Harmonic Distortion	THDD	30kHz LPF $T_d=20.5ms$	-	0.5	0.9	%
		$T_d=51.2ms$	-	1.2	2.2	%
		$T_d=184ms$	-	3.0	5.6	%
Maximum Output Voltage	V_{omaxD}	THD=10%	0.7	1.0	-	Vrms
Output Noise Voltage	NoD	$V_{in}=0V_{rms}$ $T_d=20.5ms$	-	-92	-80	dBV
		JIS-A $T_d=51.2ms$	-	-84	-70	dBV
		$T_d=184ms$	-	-80	-65	dBV
LPF Cut-off Frequency	LPFfc	$T_d=15.4$ to $51.2ms$, $G_v=-3dB$	6.0	7.0	8.0	kHz
		$T_d=123, 184ms$, $G_v=-3dB$	-	3.0	-	kHz
◆ Feedback Volume						
Maximum attenuation	$FBATT_{max}$	ATT=- ∞ dB	-	-70	-60	dB
Minimum attenuation	$FBATT_{min}$	ATT=-3dB	-6.0	-3.0	0	dB
Volume Step	FBVOLS		1.5	3.0	4.5	dB
◆ Delay Volume						
Maximum attenuation	$DLATT_{max}$	ATT=- ∞ dB	-	-70	-60	dB
Minimum attenuation	$DLATT_{min}$	ATT=-3dB	-3.0	0	3.0	dB
Volume Step	DLVOLS		1.5	3.0	4.5	dB

APPLICATION CIRCUIT

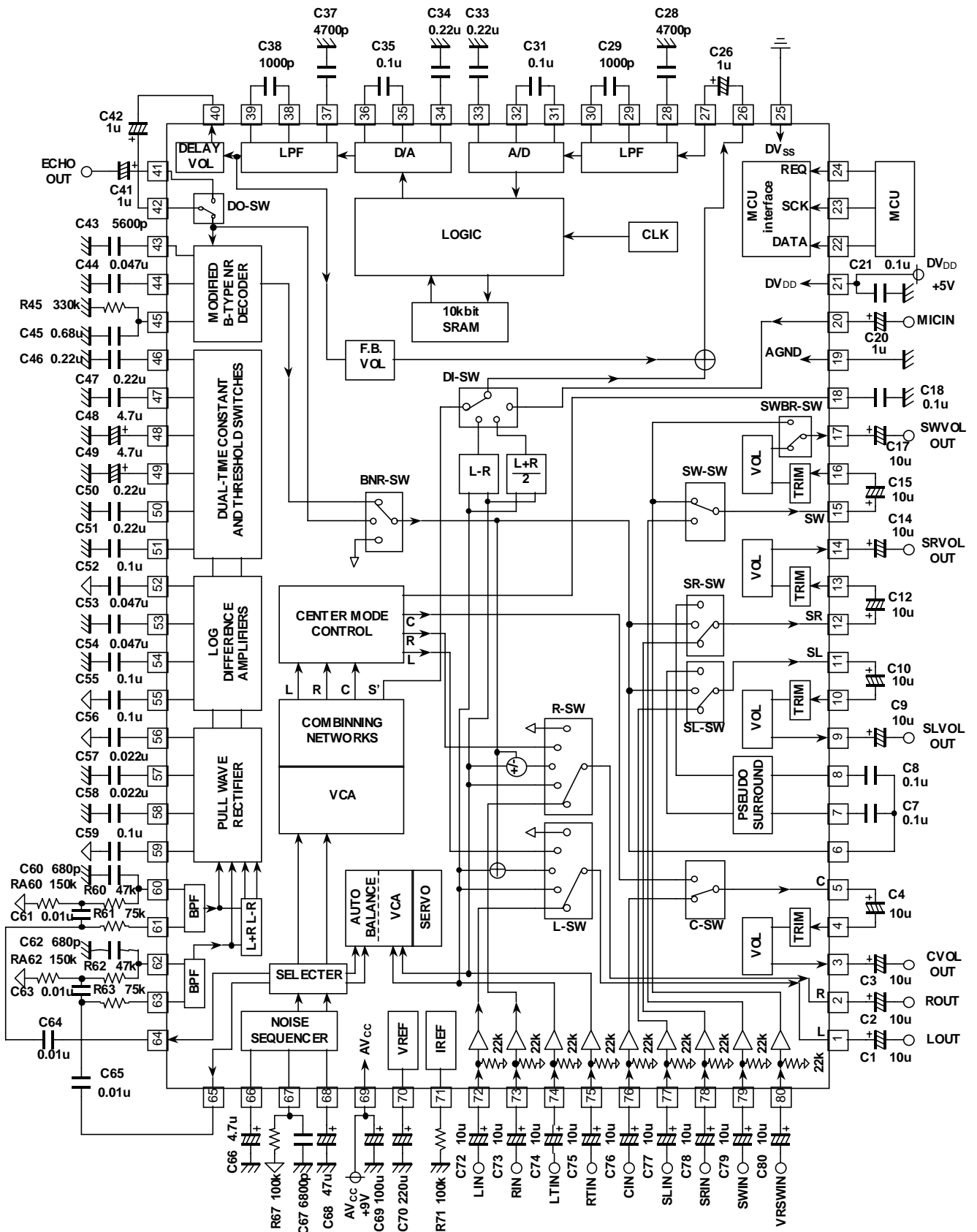

NJW1107

■ CONTROL DATA FORMAT

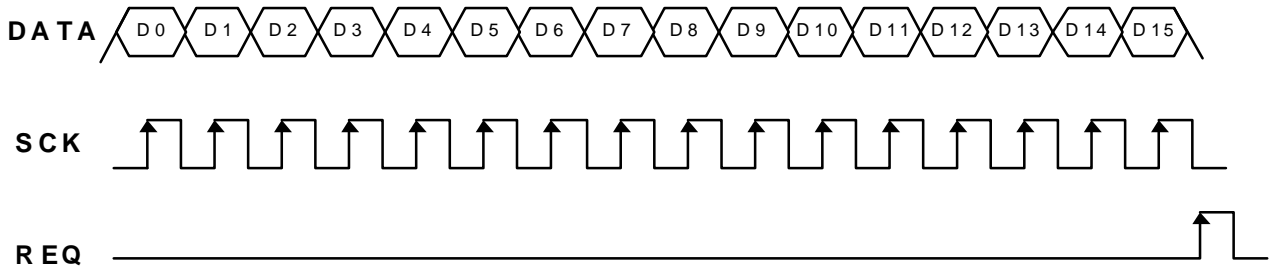

D0	D1	D2	D3	D4	D5	D6	D7	D8	D9	D10	D11	D12	D13	D14	D15	
0	0	0	-	Mode Set			Pro Logic Mode	Center Mode	Auto-Balance	Noise Sequencer			0	1		
		1	-	0	Delay Time			Other Surround Mode								
0	1	0	0	Delay Volume			Cch Volume			Chip Address						
		0	1	Feedback Volume			SLch Volume									
		1	0	-	-	-	SRch Volume									
		1	1	-	-	SW-VOL Set	SWch Volume									
1	0	0	-	Cch Trimmer				SWch Trimmer								
		1	-	SLch Trimmer				SRch Trimmer								
1	1	Test Mode (user inhibit)														

“-”: Don't care

■ DETAILED CONTROL DATA DESCRIPTION

No	Control Mode	Description
1	Mode Set	Analog 5.1ch / Bypass / Pro Logic / Other Surround / Echo / Mute
2	Pro Logic Mode	4ch Pro Logic / 3ch Stereo
3	Center Mode	Wide / Normal / Phantom / OFF
4	Auto-Balance	ON / OFF
5	Noise Sequencer	ON / OFF Lch / Cch / Rch / Sch
6	Delay Time	15.4, 20.5, 25.6, 29.2, 51.2 ms (Short Delay) 123, 184 ms (Long Delay)
7	Other Surround Mode	L/R Output : Pro Logic / Other Surround Mixing Polarity: Invert / Non-Invert Delay Input : S' / L-R / (L+R)/2 BNR : ON / OFF Pseudo Stereo : ON / OFF
8	Master Volume	C, SL, SR, SW ch Master Volume 0 to -79dB / 1dB step & -∞
9	SW Volume Set	Through / Bypass
10	Delay Volume	0 to -18dB / 3dB step & -∞
11	Feedback Volume	-3 to -21dB / 3dB step & -∞
12	Trimmer	C, SL, SR, SW ch Trimmer 0 to -31dB / 1dB step & -∞

1. 1st byte

D0	D1	D2	D3	D4	D5	D6	D7	D8	D9	D10	D11	D12	D13	D14	D15
0	0	0	-	Mode Set			Pro Logic Mode	Center Mode		Auto-Balance	Noise Sequencer			0	1

1-1. Mode Set

D4	D5	D6	Mode Set
0	0	0	Analog 5.1ch
0	0	1	Bypass
0	1	0	Dolby Pro Logic Surround
0	1	1	Other Surround
1	0	0	Echo
1	0	1	Mute

1-2. Pro Logic Mode

D7	Pro Logic Mode
0	4ch Pro Logic
1	3ch Stereo

1-3. Center Mode

D8	D9	Center Mode
0	0	Wide
0	1	Normal
1	0	Phantom
1	1	OFF

NJW1107

1-4. Auto-Balance

D10	Auto-Balance
0	OFF
1	ON

1-5. Noise Sequencer

D11	D12	D13	Noise Sequencer
0	-	-	OFF
1	0	0	ON Lcn
1	0	1	ON Rch
1	1	0	ON Cch
1	1	1	ON Sch

2. 2nd byte

D0	D1	D2	D3	D4	D5	D6	D7	D8	D9	D10	D11	D12	D13	D14	D15
0	0	1	-	0	Delay Time			Other Surround Mode					0	1	

2-1. Delay Time

D5	D6	D7	Delay Time
0	0	0	15.4ms, fs=500kHz, LPF:7kHz
0	0	1	20.5ms, fs=500kHz, LPF:7kHz
0	1	0	25.6ms, fs=400kHz, LPF:7kHz
0	1	1	29.2ms, fs=333kHz, LPF:7kHz
1	0	0	51.2ms, fs=200kHz, LPF:7kHz
1	0	1	123ms, fs=83.3kHz, LPF:3kHz
1	1	0	184ms, fs=55.6kHz, LPF:3kHz

2-2. Other Surround Mode

D8	L/R Output
0	Pro Logic
1	Other Surround

D9	Mixing Polarity
0	Invert
1	Non-Invert

D10	D11	Delay Input
0	-	S'
1	0	L-R
1	1	(L+R)/2

D12	BNR
0	OFF
1	ON

D13	Pseudo Stereo
0	OFF
1	ON

3. 3rd – 6th byte

D0	D1	D2	D3	D4	D5	D6	D7	D8	D9	D10	D11	D12	D13	D14	D15
0	1	0	0	Delay Volume			Cch Volume						0	1	
			1	Feedback Volume			SLch Volume								
		1	-0	-	-	-	SRch Volume								
			-1	-	-	SW-VOL Set	SWch Volume								

3-1. C, LS, RS, SW ch Master Volume

D7	D8	D9	D10	D11	Volume Level
0	0	0	0	0	0dB
1	0	0	0	0	-2dB
0	1	0	0	0	-4dB
1	1	0	0	0	-6dB
0	0	1	0	0	-8dB
1	0	1	0	0	-10dB
0	1	1	0	0	-12dB
1	1	1	0	0	-14dB
0	0	0	1	0	-16dB
1	0	0	1	0	-18dB
0	1	0	1	0	-20dB
1	1	0	1	0	-22dB
0	0	1	1	0	-24dB
1	0	1	1	0	-26dB
0	1	1	1	0	-28dB
1	1	1	1	0	-30dB
0	0	0	0	1	-32dB
1	0	0	0	1	-34dB
0	1	0	0	1	-36dB
1	1	0	0	1	-38dB
0	0	1	0	1	-40dB
1	0	1	0	1	-42dB
0	1	1	0	1	-44dB
1	1	1	0	1	-48dB
0	0	0	1	1	-52dB
1	0	0	1	1	-56dB
0	1	0	1	1	-60dB
1	1	0	1	1	-64dB
0	0	1	1	1	-68dB
1	0	1	1	1	-72dB
0	1	1	1	1	-76dB
1	1	1	1	1	-∞

D12	D13	Volume Level
0	0	0dB
1	0	-1dB
0	1	-2dB
1	1	-3dB

3-2. SW-VOL set

D6	SW-VOL Set
0	Bypass Volume
1	Through Volume

NJW1107

3-3. Delay Volume

D4	D5	D6	Delay Volume
0	0	0	0dB
0	0	1	-3dB
0	1	0	-6dB
0	1	1	-9dB
1	0	0	-12dB
1	0	1	-15dB
1	1	0	-18dB
1	1	1	-∞

3-4. Feedback Volume

D4	D5	D6	Feedback Volume
0	0	0	-3dB
0	0	1	-6dB
0	1	0	-9dB
0	1	1	-12dB
1	0	0	-15dB
1	0	1	-18dB
1	1	0	-21dB
1	1	1	-∞

4. 7th – 8th byte

D0	D1	D2	D3	D4	D5	D6	D7	D8	D9	D10	D11	D12	D13	D14	D15
1	0	0	-	Cch Trimmer				SWch Trimmer				0	1		
		1	-	SLch Trimmer				SRch Trimmer							

4-1. C, LS, RS, SW ch Trimmer

D4 /D9	D5 /D10	D6 /D11	D7 /D12	D8 /D13	Trimmer Level
0	0	0	0	0	0dB
1	0	0	0	0	-1dB
0	1	0	0	0	-2dB
1	1	0	0	0	-3dB
0	0	1	0	0	-4dB
1	0	1	0	0	-5dB
0	1	1	0	0	-6dB
1	1	1	0	0	-7dB
0	0	0	1	0	-8dB
1	0	0	1	0	-9dB
0	1	0	1	0	-10dB
1	1	0	1	0	-11dB
0	0	1	1	0	-12dB
1	0	1	1	0	-13dB
0	1	1	1	0	-14dB
1	1	1	1	0	-15dB

D4 /D9	D5 /D10	D6 /D11	D7 /D12	D8 /D13	Trimmer Level
0	0	0	0	1	-16dB
1	0	0	0	1	-17dB
0	1	0	0	1	-18dB
1	1	0	0	1	-19dB
0	0	1	0	1	-20dB
1	0	1	0	1	-21dB
0	1	1	0	1	-22dB
1	1	1	0	1	-23dB
0	0	0	1	1	-24dB
1	0	0	1	1	-25dB
0	1	0	1	1	-26dB
1	1	0	1	1	-27dB
0	0	1	1	1	-28dB
1	0	1	1	1	-29dB
0	1	1	1	1	-30dB
1	1	1	1	1	-31dB

When total attenuation (Volume level + Trimmer level) is less than -87dB, maximum attenuation level is held at -87dB.

DATA TIMING

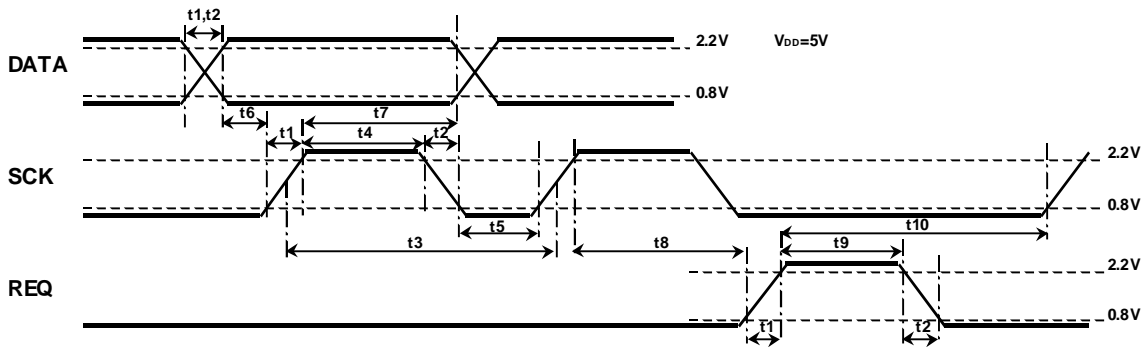

PARAMETER	SYMBOL	TEST CONDITION	MIN.	TYP.	MAX.	UNIT
Signal rise time	t1		-	-	0.5	μs
Signal fall time	t2				0.5	
SCK clock width	t3		2			
SCK "H" pulse width	t4		0.8	-	-	
SCK "L" pulse width	t5		0.8	-	-	
DATA setup time	t6		0.8	-	-	
DATA hold time	t7		0.8	-	-	
REQ rise hold time	t8		1.6	-	-	
REQ "H" pulse width	t9		0.8	-	-	
SCK setup time	t10		1.6	-	-	

NOTICE

The NJW1107 includes Auto-Reset circuit. The NJW1107 requires both analog power supply (AV_{CC}) and digital power supply (DV_{DD}). Internal digital circuits are initialized by AV_{CC} . The internal reset signal is released after t_{reset} period ($0.7\text{sec.} < t_{reset} < 1.3\text{sec.}$).

Power-on Sequence

1. Turn the AV_{CC} on first.
2. Provide the DV_{DD} within 0.7 seconds after the AV_{CC} turns on.
3. Keep the voltage of DV_{DD} below the voltage of AV_{CC} always.
4. Wait for 1.3 seconds and over after the AV_{CC} turns on.
5. Transmit the control data from MCU.

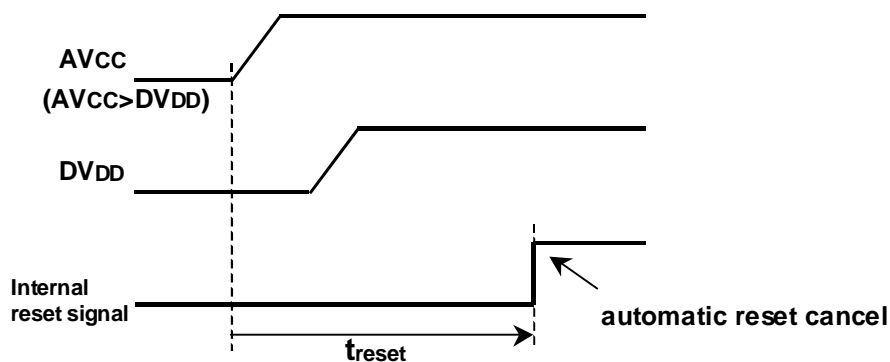

MEMO

[CAUTION]

The specifications on this databook are only given for information, without any guarantee as regards either mistakes or omissions. The application circuits in this databook are described only to show representative usages of the product and not intended for the guarantee or permission of any right including the industrial rights.