

HID & SYSTEM MANAGEMENT PRODUCTS, MOUSECODER™ FAMILY
DESCRIPTION

The ScreenCoder™ PS2 is a high-performance IC that interfaces any 4 or 8-wire resistive touch screen to the standard PS/2 mouse port. Low-power and tiny, the single IC is ideal for portable systems, web phones and interactive kiosks. It offers an advanced algorithm for enhanced motion control as well as an extra port for hot-plug connection of an external PS/2 pointing device. Both the touch screen and the external device can be operated concurrently without any penalty.

The UR7HCTS2-P840 is equipped with a special command protocol that enables the touch screen to operate in either relative (mouse-like) or absolute positioning mode. Because the IC interfaces via the PS/2 mouse port, it can utilize any standard mouse driver when operating in relative mode. For absolute positioning, offers a high-functionality driver which includes inking capabilities.

Mice connected to the ScreenCoder™ PS2 external mouse port will always act in relative mode, even if the touch screen is operating in the absolute mode. The PS/2 communication channel is bi-directional at 10 kbps.

The ScreenCoder™ PS2 offers built-in A/D. Touch detection and motion are handled in firmware, and no digitizer is required. The cost-effective solution requires few external components, allowing for a simple and real estate saving implementation.

FEATURES

- Controller & digitizer in a single IC; no need for external A/D
- Interfaces ANY 4- or 8-wire resistive touch screen to standard PS/2 mouse port; regardless of size, material or vendor
- High-performance IC offers accurate cursor control due to advanced algorithms
- Low-power consumption, due to sophisticated power management states, ideal for battery-operated systems
- Highly resistant to RF & other noise sources
- Enables hot-plug connection of an external pointing device
- Wheelmouse functionality is supported in the external pointing device
- Other interfaces available
- Embedded touch screen and external pointing device can operate concurrently with no performance penalty
- Supports both absolute and relative (mouse-like) modes of operation
- For relative mode, no special drivers are needed; high-functionality driver available for absolute mode
- Supports all commands defined in the IBM PS/2 Mouse Communication Protocol, as well as Semtech's extended PS/2 communication protocol with absolute positioning support
- Available in a low-profile 32-pin LQFP package
- Few external components required

APPLICATIONS

- Portable systems
- Notebooks and Laptops
- Interactive Kiosks
- Touch-enabled monitors

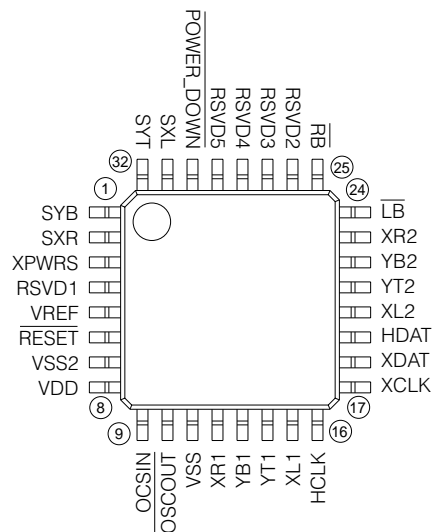
PIN ASSIGNMENTS

ORDERING CODE

Package Options	Pitch in mm's	TA=-20° C to +85° C
32-pin, Plastic LQFP	0.5	UR7HCTS2-P840-FG

Other Materials	Type	Order number
ScreenCoder™ PS2 Eval. Kit	Evaluation Kit	EVK7-TS2-P840-XXX

Note 1: XXX= Denotes Revision number

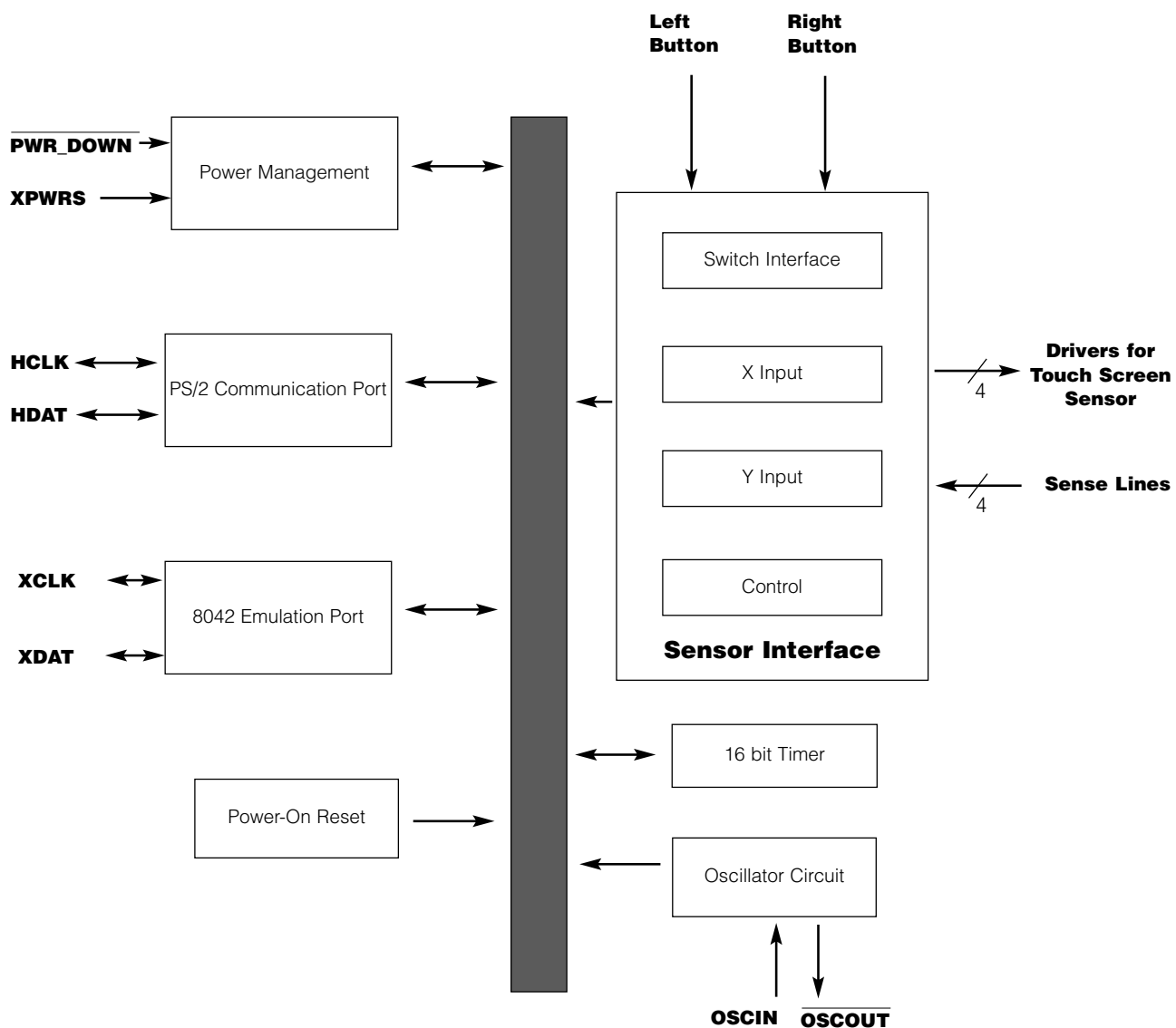
BLOCK DIAGRAM

PIN DEFINITIONS

Mnemonic	Pin #	Type	Name and Function
VDD	8	P	Power Supply
VSS	11	P	Ground
VSS2	7	P	Ground
OSCIN	9	I	Oscillator Input: external clock input or one side of the Ceramic Resonator with built-in Load Capacitors
<u>_</u> OSCOUT	10	O	Oscillator Output: open for external clock input or other side of the Ceramic Resonator with built-in Load Capacitors
<u>_</u> RESET	6	I	Reset: apply 0V to provide orderly start-up
HDAT	19	I/O (nd)	Mouse Data: connects to Host's data line
HCLK	16	I/O (nd)	Mouse Clock: connects to Host's clock line
XCLK	17	I/O (nd)	External Mouse Clock: PS/2 clock signal from external mouse; keep open if unused
XDAT	18	I/O (nd)	External Mouse Data: PS/2 data signal from external mouse; keep open if unused
<u>_</u> LB	24	I/O (nd)	Left Button: active low, strobed sampling
<u>_</u> RB	25	I/O (nd)	Right Button: active low, strobed sampling
XR1	12	I/O	Sensor's Excitation Driver: connect to X Right
YB1	13	I/O	Sensor's Excitation Driver: connect to Y Bottom
YT1	14	I/O	Sensor's Excitation Driver: connect to Y Top
XL1	15	I/O	Sensor's Excitation Driver: connect to X Left
XL2	20	I/O	Sensor's Excitation Driver: connect to X Left
YT2	21	I/O	Sensor's Excitation Driver: connect to Y Top
YB2	22	I/O	Sensor's Excitation Driver: connect to Y Bottom
XR2	23	I/O	Sensor's Excitation Driver: connect to X Right
VREF	5	AI	Reference Voltage for built-in A/D
SXL	31	AI	Sense line: for X Left
SYT	32	AI	Sense line: for Y Top
SYB	1	AI	Sense line: for Y Bottom
SXR	2	AI	Sense line: for X Right
<u>_</u> POWER_ DOWN	30	I	Hardware Power Down: tie high if unused
XPWRS	3	AI	External Mouse Power Sense: tie high if unused and external mouse port is used; tie low if external mouse port is unused
RSVD1-5	4, 26 27-29	I/O	Reserved

Note: An underscore before a pin mnemonic denotes an active low signal.

Pin Types Legend: AI=Analog Input; I=Input; O=Output; I/O=Input or Output; I/O (nd)=Input or Output with N-channel Open Drain driver



FUNCTIONAL DESCRIPTION

The ScreenCoder™ UR7HCTS2-P840 consists functionally of six major sections (see the Functional Diagram on page 2). These are the Sensor Interface, Power Management section, the 16-Bit Timer, the Oscillator Circuit, the PS/2 Communication Port and the 8042 Emulation Port. All sections communicate with each other and operate concurrently.

SENSOR INTERFACE

To obtain position information from the Resistive Touch Screen Sensor, the ScreenCoder™ PS2 uses four internal drivers (two pins for each driver) and four sensing lines. During sampling, first the drivers and sensing lines for X axis are activated, by setting one X driver high and the other X driver low; the drivers for Y axis are set floating. This action produces a voltage gradient across the touch screen's surface in the X direction.

The internal A/D measures both the voltage across the activated X plane and the voltage potential between the planes. Next, the drivers for the Y axis are activated, while the drivers for the X axis are set floating. Again, the internal A/D measures both voltage across the activated plane and potential between the planes. The X and Y absolute position information is calculated from these four A/D measurements.

Before the measurement of X and Y positions, the ScreenCoder™ PS2 checks if there is any touch pressure applied to the sensor. Proprietary touch detection algorithm performs this test very quickly, accommodating sensors with various plate-to-plate capacitances. Actual measurements are somewhat more complex and are covered by a US and international patent currently pending.

OSCILLATOR

This IC has a built-in Oscillator circuit capable of operations with an external 4.00 MHz Clock source, or a Ceramic Resonator (preferably with built-in Load Capacitors). Note that the Crystals can NOT be used. The ScreenCoder™ PS2 frequently switches its Oscillator OFF and ON in order to operate with the least amount of power consumption. Due to their very high Q, the Crystal-based oscillators have exceedingly long Start-up times and can NOT be used with the ScreenCoder™ PS2.

PS/2 COMMUNICATION

At start-up, or upon receiving a reset command, the UR7HCTS2-P840 will wait between 300 and 500 milliseconds before sending an AAh to the Host followed by a device ID of 00h. The IC will then set itself to its default values (i.e., Incremental Stream Mode with 1:1 scaling, and a report rate of 100 Hz). The device will then disable itself until an Enable (F4h) command is sent from the Host.

ERROR HANDLING

For every correct command or parameter received from the Host, the UR7HCTS2-P840 sends an Acknowledge (FAh). If an invalid command or parameter is received, the UR7HCTS2-P840 issues a Resend Request (FEh). If an invalid input is again received, the device transmits an Error Code (FCh) to the Host.

Both Error and Resend Request responses are sent by the device within 25 milliseconds. Host may not issue any new commands until either the ScreenCoder™ PS2 has responded or until 25 milliseconds have elapsed.

POWER MANAGEMENT

The ScreenCoder™ PS2 implements two power management methods: Self-Power Management™ and System-coordinated Power Management.

Self-Power Management

Self-Power Management™ of the ScreenCoder™ PS2 permits, independently of any system intervention, the lowest power consumption possible within the present parameters and conditions of operation. Through Self-Power Management™, the ScreenCoder™ PS2 is capable of operating - most of the time - at only 1uA, independently of the state of the system.

POWER MANAGEMENT (CON'T)

The "Stop" mode is the lowest power consumption mode. In this mode, the oscillator is stopped and the IC consumes only the leakage current. This is the default mode to which the IC will revert when it is idle. An event or signal conditions wake-up the IC. The ScreenCoder™ PS2 can still operate most of the time at only 1uA, even when the host is in the active state, and with active external PS/2 device attached to the ScreenCoder™ PS2. If an external PS/2 device sends a data packet, the ScreenCoder™ PS2 will exit the "Stop" mode for as long as it takes to process the message and relay the information to the system. This operation is done transparently to the host, without any data loss or any response delay from the input device.

System-coordinated Power Management
Normal Operation State

In normal operation state, both `_PWR_DOWN` and `XPWRS` pins are in high state. ScreenCoder™ PS2 operations are controlled by Self-Power Management™.

Critical Suspend

At any time, the Host may negate the `_PWR_DOWN` pin in order to force the ScreenCoder™ PS2 into a "Critical suspend" mode. This signal can be activated (driven low) due to specific conditions of the Host's operations (for example, a discharged battery), or due to actions of the Operating System or BIOS.

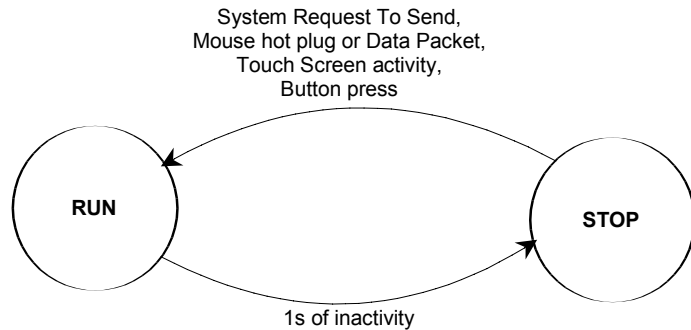
Figure 1: Semtech's Self-Power Management™ State

POWER MANAGEMENT (CON'T)

During the "Critical suspend", the ScreenCoder™ will shut down all of the pointing activities. However, the communications with the Host are still enabled.

External PS/2 power down

The ScreenCoder™ PS2 monitors the power state of the external PS/2 pointing device through the `XPWRS` pin. If the IC senses that the external PS/2 device has been powered-down by the host, it will actively eliminate shot-through current in the input buffers for the clock and data lines by driving both low.

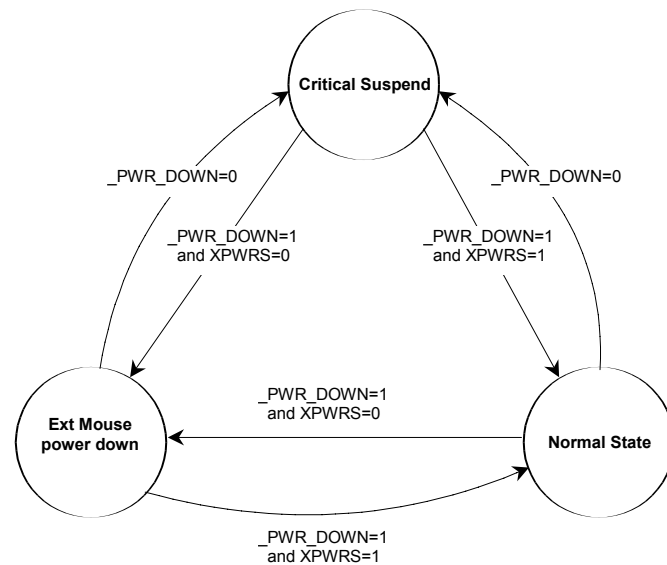
The ScreenCoder™ UR7HCTS2-P840 will re-initialize the external PS/2 pointing device when the power to the external PS/2 port is restored.

Figure 2: Semtech's System-coordinated Power Management



PS/2 DATA FORMAT

The following table shows the data report format. X and Y values are expressed as 9-bit Two's Complement signed integers, with the sign bit / most significant bit separate. If there is an overflow of the accumulator, the maximum positive or negative count is reported and the corresponding overflow bit is set.

EXTENDED PS/2 PROTOCOL

Semtech offers a high-performance driver for Windows 95, Windows 98, Windows Me, and Windows NT. Please check with Semtech for other driver availability.

Those that wish to undertake their own driver development will need to request from Semtech the document covering the extended PS/2 protocol used by the UR7HCTS2-P840.

DATA REPORT FORMAT TABLE

Byte 1		
b0	Left Button status	1 = depressed
b1	Right Button Status	1 = depressed
b2	Middle Button Status	1 = depressed
b3	Reserved	Always = 1
b4	X8: MSb of X data, sign bit	1 = negative
b5	Y8: MSb of Y data, sign bit	1 = negative
b6	X data overflow	1 = overflow
b7	Y data overflow	1 = overflow
Byte 2		
b0	X0: LSb of X data	
b1	X1	
b2	X2	
b3	X3	
b4	X4	
b5	X5	
b6	X6	
b7	X7:	
Byte 3		
b0	Y0: LSb of Y data	
b1	Y1	
b2	Y2	
b3	Y3	
b4	Y4	
b5	Y5	
b6	Y6	
b7	Y7:	
Byte 4 (only for Wheelmouse-type devices)		
b0	Z0: LSb of Z data	
b1	Z1	
b2	Z2	
b3	Z3	
b4	Z4	
b5	Z5	
b6	Z6	
b7	Z7: MSb of Z data	

STATUS REPORT FORMAT TABLE

Byte 1		
b0	Right Button	1 = depressed
b1	Middle Button	1 = depressed
b2	Left Button	1 = depressed
b3	Reserved	Always = 0
b4	Scaling - 1:1 (0) / 2:1 (1)	
b5	Disable - (0) / enable (1)	
b6	Stream - (0) / prompt (1) mode	
b7		Always = 0
Byte 2		
b0 - 1	Current resolution setting	
b2 - 7		Always = 0
Byte 3		
b0-7	Current sampling rate	

PS/2 MODE COMMANDS

When the **Reset Command (FFh)** is received, the UR7HCTS2-P840 sets the following default parameters: Incremental Stream Mode, 1:1 scaling, report rate of 100 Hz, and disabled. It then sends AAh to the host followed by a device ID of 00h.

The Host sends the **Resend Last Data Stream Command (FEh)** when the host detects an error in any UR7HCTS2-P840 transmission. The device then resends the last output data packet to the Host. This transmission occurs after a ScreenCoder™ PS2 transmission and before the Host enables the interface allowing the next ScreenCoder™ PS2 output.

The **Set Default Status Command (F6h)** re-initializes the device to its condition at power-up.

The **Disable Command (F5h)** stops the device from transmitting all reports. However, the mode does not change; the ScreenCoder™ PS2 is still able to respond to commands. If the Disable Command is issued while the device is transmitting a report, the UR7HCTS2-P840 immediately stops the transmission and disables itself.

The **Reset Echo Mode Command (ECh)** returns the device to its previous mode, and disabled.

The **Set Prompt (Remote) Mode Command (F0h)** sets the device to Prompt Mode. Data values are then only reported in response to a **Read Report Command (EBh)**.

If the **Set Echo Mode Command (EEh)** is received, the ScreenCoder™ PS2 will immediately return any data bytes except FFh or ECh.

If the ScreenCoder™ PS2 is in Incremental Stream Mode, the **Enable Command (F4h)** will allow it to begin data transmission. If the device is in Prompt Mode, the Enable Command will only update the internal status of the ScreenCoder™ PS2.

The ScreenCoder™ PS2 will respond to the **Set Sampling Rate Command (F3h)** in both Stream and Prompt Modes but will only update its internal status if this command is enacted while the device is in the Stream Mode.

The UR7HCTS2-P840 responds to the **Read Device Type Command (F2h)** with the device ID of 00h.

The **Read Report Command (EBh)** prompts the ScreenCoder™ PS2 for a report. The report occurs even if the device has not moved or if the status of the switches did not change.

The **Set Incremental Stream Mode Command (EAh)** sets the ScreenCoder™ PS2 to Stream Mode and disables the device.

The **Status Request Command (E9h)** returns a 3-byte status report.

The **Set Resolution Command (E8h)** controls resolution, the **Set 2:1 Scaling Command (E7h)** enables a coarse/fine tracking response, and the **Set 1:1 Scaling Command (E6h)** enables the values of movements to be transmitted to the Host without any scaling. Due to Semtech's Advanced Motion Algorithm, Set Resolution and Scaling Commands are acknowledged and reported as activated, but their status is ignored.



SEQUENTIAL COMMANDS

Unlike normal commands, sequential commands must be enacted with a sequence of commands. If the sequence is not consecutive or is incorrect, the ScreenCoder™ PS2 aborts the detection and responds the way it would normally respond to a command.

The individual commands that comprise a sequential command have been designed so that the elements of a sequential command can be sent to the ScreenCoder™ PS2 via the standard IBM PS/2 BIOS calls and the device returns a valid response to the Status Request. This ensures that, if the sequential command is sent via the BIOS, the status response will be accurately returned even if the BIOS performs error detection. Thus, a programmer can have complete control of the mouse without having to access the device hardware port directly.

The UR7HCTS2-P840 implements a special sequential command that can be used to determine its ability to report three buttons. The sequential command is a series of commands to the ScreenCoder™ PS2 that cause the device to respond to the last command (Read Status) with alternate information.

The sequence of commands is as follows.

1. Set Resolution = one count/ mm (E8H)
2. Set Scaling = 1:1 (E6H)
3. Set Scaling = 1:1 (E6H)
4. Set Scaling = 1:1 (E6H)
5. Read Status (E9H)

The response to the Read Status Command is in the following format.

Byte 1: Standard Status Information (buttons, scaling, etc.)

Byte 2: Number of mouse buttons (3)

Byte 3: Firmware Revision Number (encoded) or current sampling rate



SCREENCODER™ PS2 ABSOLUTE AND RELATIVE POSITIONING MODES OF OPERATION

The ScreenCoder™ PS2 supports both absolute and relative positioning modes. Details on how to use the IC in each mode are specified below.

ABSOLUTE POSITIONING MODE

To enable the ScreenCoder™ PS2 to operate in an absolute positioning mode, a ScreenCoder™ PS2 driver, or a driver compliant to the Semtech's Extended PS/2 protocol, must be installed. ScreenCoder™ PS2 drivers are available for use under Windows 95, Windows 98, Windows Me, and Windows NT. Other operating systems are also supported; please call Semtech for details. For Commands and Data Report organization, please refer to the *Semtech Extended PS/2 Protocol with Absolute Positioning Mode Support* document.

RELATIVE POSITIONING MODE

In relative positioning mode, the ScreenCoder™ PS2 operates like a normal mouse, using a standard system mouse driver.

Button functionality can be achieved as follows: actual switches will act as left and right buttons, or a tap on the screen will act as a left-button click.

By tapping on the touchscreen, the user can invoke click, double-click, and click-and-drag functions.

To click, lightly and quickly tap the surface of the touchscreen once.

To double click, rapidly tap on the touchscreen twice.

To click and drag, double-tap rapidly and hold your finger down on the second tap, then glide to move.



SEMTECH

SUGGESTED INTERFACING FOR THE SCREENCODER™ PS2 UR7HCTS2-P840-FG

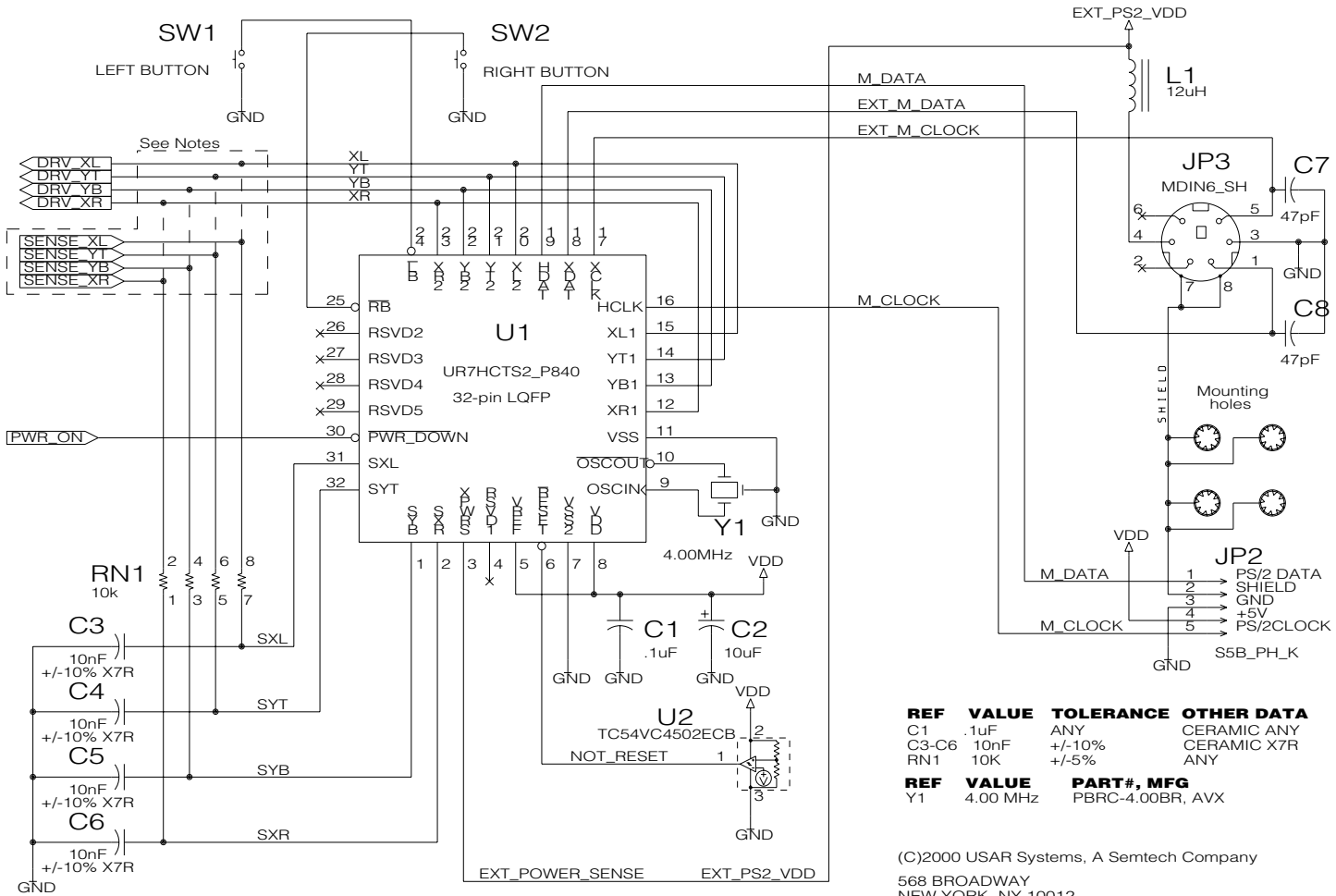

REF	VALUE	TOLERANCE	OTHER DATA
C1	.1uF	ANY	CERAMIC ANY
C3-C6	10nF	+/-10%	CERAMIC X7R
RN1	10K	+/-5%	ANY
REF	VALUE	PART#, MFG	
Y1	4.00 MHz	PBRC-4.00BR, AVX	

(C)2000 USAR Systems, A Semtech Company
 568 BROADWAY
 NEW YORK, NY 10012
 Ph 212.226.2042 Fax 212.226.3215
 ScreenCoder II UR7HCTS2-P840-FG
 UR7HCTS2P840 Rev 0.8

NOTES:

P840 == PS/2 In/Out, 4.00 MHz, 8/4-wire, Model 0.
 Connect Drive and Sense lines together for the 4-wire Sensor.
 Y1 == 4.00 MHz Ceramic Resonator with Built-in Load Capacitors.
 Crystals can NOT be used.

SilkScreen top

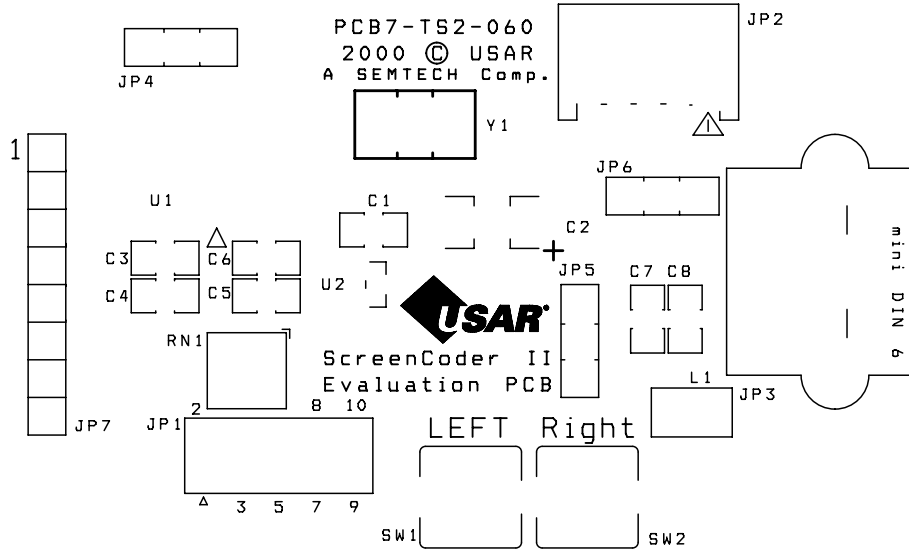

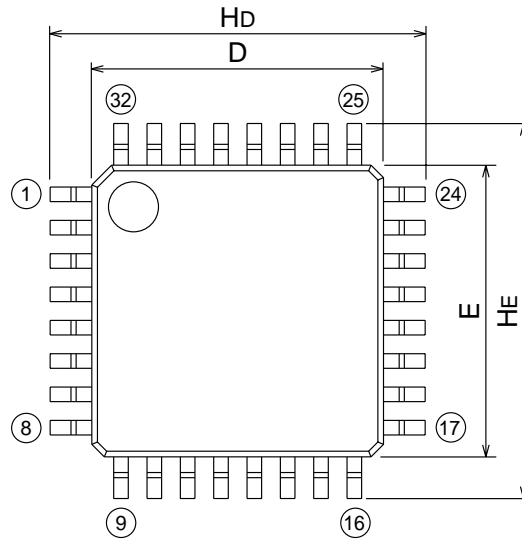
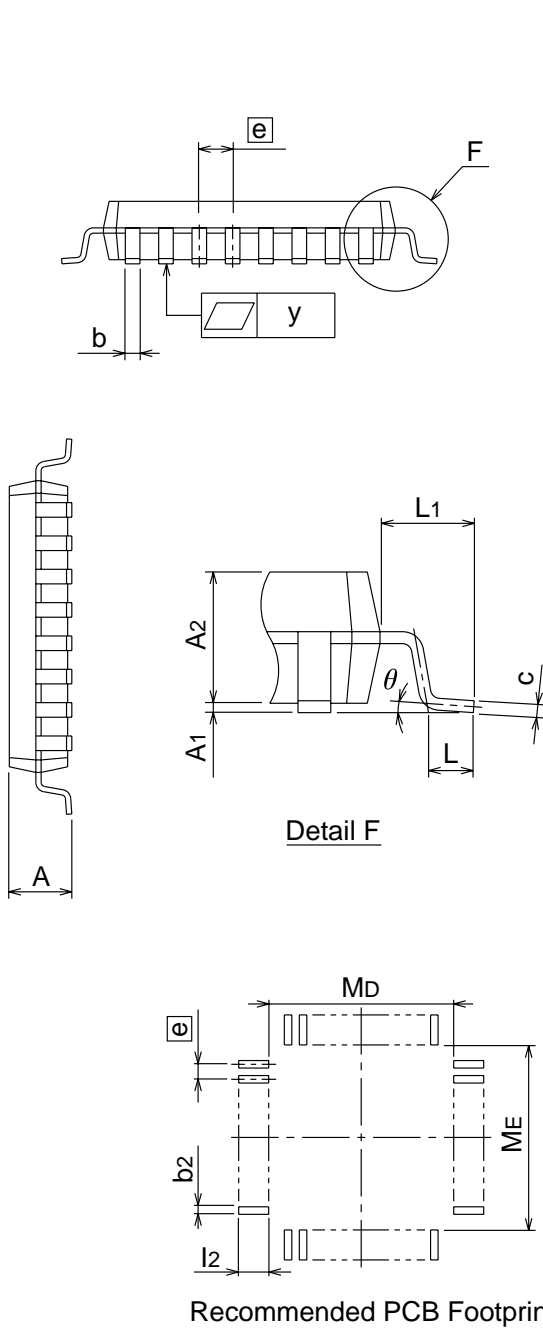

Symbol	Dimension in Millimeters		
	Min	Nom	Max
A	–	–	1.7
A1	0	0.1	0.2
A2	–	1.4	–
b	0.3	0.35	0.45
c	0.105	0.125	0.175
D	6.9	7.0	7.1
E	6.9	7.0	7.1
e	–	0.8	–
Hd	8.8	9.0	9.2
HE	8.8	9.0	9.2
L	0.3	0.5	0.7
L1	–	1.0	–
y	–	–	0.1
θ	0 $^\circ$	–	10 $^\circ$
b2	–	0.5	–
l2	1.0	–	–
MD	–	7.4	–
ME	–	7.4	–



ELECTRICAL SPECIFICATIONS

Absolute Maximum Ratings

Ratings	Symbol	Value	Unit
Supply Voltage	Vdd	-0.3 to 7.0	V
Input Voltage	Vin	Vss -0.3 to Vdd +0.3	V
Current Drain per Pin (not including Vss or Vdd)	I	20	mA
Operating Temperature	Ta	T low to T high	°C
UR7HCTS2-P840		-20 to +85	°C
Storage Temperature Range	Tstg	-40 to +125	°C

DC Electrical Characteristics, Temperature range=T low to T high unless otherwise noted)

Characteristic	Symbol	Min	Typ	Max	Unit
Supply Voltage		3.0	5.0	5.5	V
Output Voltage (10 μ A load)	Voh	Vdd-0.1			V
	Vol			0.1	
Input High Voltage	Vih	0.8 x Vdd		Vdd	V
Input Low Voltage	Vil	Vss		0.2xVdd	V
Input Current	Iin			+/- 10	μ A
Supply Current (Vdd=5.0 Vdc +/-10%, Vss=0)	Idd		3.0	TBD	mA

Control Timing (Vdd=5.0 Vdc +/-10%, Vss=0 Vdc, Temperature range=T low to T high unless otherwise noted)

Characteristic	Symbol	Min	Typ	Max	Unit
Frequency of Operation	fosc				MHz
■ Crystal Option			4.0		
■ External Clock Option			4.0		



SCREENCODER™ PS2 BILL OF MATERIALS FOR PAGE 10 SCHEMATIC

UR7HCTS2-P840-FG BOM

Description	Quantity	Manufacturer	Part#	Description
Capacitors:				
C1	1	Generic	Any	.1uF, 10%, Ceramic, X7R or Z5U
C2	1	Generic	Any	10uF, 10V, +80%/-20%, Tantalum
C3, C4, C5, C6	4	Generic	Any	10nF, 10%, Ceramic, X7R
C7, C8	2	Generic	Any	47pF, 10%, Ceramic, X7R
ICs:				
U1	1	Semtech	UR7HCTS2-P840-FG	ScreenCoder™ PS/2 Controller
U2	1	Telcom	TC54VC4502ECB	Reset IC
Resistor Network				
RN1	1	Generic	Any	10K, 4 independent resistors
Resonator:				
Y1	1	AVX	PBRC-4.00BR	4.00MHz Ceramic Resonator w/ Caps, SMT
Inductor				
L1	1	Generic	Any	12uH Inductor

Note: Auxillary components are not shown.



**For sales information
and product literature,
contact:**

HID & System Mgmt Division
Semtech Corporation
568 Broadway
New York, NY 10012
hidinfo@semtech.com
<http://www.semtech.com>
212 226 2042 Telephone
212 226 3215 Telefax

Semtech Western Regional Sales
805-498-2111 Telephone
805-498-3804 Telefax

Semtech Central Regional Sales
972-437-0380 Telephone
972-437-0381 Telefax

Semtech Eastern Regional Sales
203-964-1766 Telephone
203-964-1755 Telefax

Semtech Asia-Pacific Sales Office
+886-2-2748-3380 Telephone
+886-2-2748-3390 Telefax

Semtech Japan Sales Office
+81-45-948-5925 Telephone
+81-45-948-5930 Telefax

Semtech Korea Sales Sales
+82-2-527-4377 Telephone
+82-2-527-4376 Telefax

Northern European Sales Office
+44 (0)2380-769008 Telephone
+44 (0)2380-768612 Telefax

Southern European Sales Office
+33 (0)1 69-28-22-00 Telephone
+33 (0)1 69-28-12-98 Telefax

Central European Sales Office
+49 (0)8161 140 123 Telephone
+49 (0)8161 140 124 Telefax

Copyright ©1999-2001 Semtech Corporation. All rights reserved. MouseCoder, ScreenCoder and Self-Power Management are trademarks of Semtech Corporation. Semtech is a registered trademark of Semtech Corporation. All other trademarks belong to their respective companies.

INTELLECTUAL PROPERTY DISCLAIMER
This specification is provided "as is" with no warranties whatsoever including any warranty of merchantability, fitness for any particular purpose, or any warranty otherwise arising out of any proposal, specification or sample. A license is hereby granted to reproduce and distribute this specification for internal use only. No other license, expressed or implied to any other intellectual property rights is granted or intended hereby. Authors of this specification disclaim any liability, including liability for infringement of proprietary rights, relating to the implementation of information in this specification. Authors of this specification also do not warrant or represent that such implementation(s) will not infringe such rights.