

FEATURES

- 3.3V core supply, 1.8V output supply for reduced power
- LVPECL and HSTL inputs
- 9 differential HSTL (low-voltage swing) output pairs
- HSTL outputs drive 50Ω to ground with no offset voltage
- 500MHz maximum clock frequency
- Low part-to-part skew (200ps max.)
- Low pin-to-pin skew (50ps max.)
- Available in 32-pin TQFP package

PIN CONFIGURATION

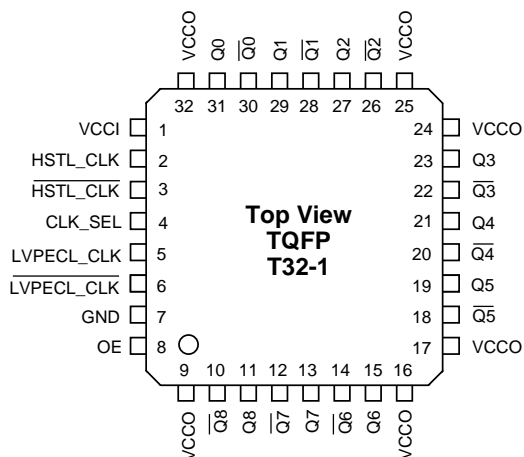

DESCRIPTION

The SY89809L is a High-Performance Bus Clock Driver with 9 differential HSTL (High-Speed Transceiver Logic) output pairs. The part is designed for use in low-voltage (3.3V/1.8V) applications which require a large number of outputs to drive precisely aligned, ultralow skew signals to their destination. The input is multiplexed from either HSTL or LVPECL (Low-Voltage Positive-Emitter-Coupled Logic) by the CLK_SEL pin. The Output Enable (OE) is synchronous so that the outputs will only be enabled/disabled when they are already in the LOW state. This avoids any chance of generating a runt clock pulse when the device is enabled/disabled as can happen with an asynchronous control.

The SY89809L features low pin-to-pin skew (50ps max.) and low part-to-part skew (200ps max.)—performance previously unachievable in a standard product having such a high number of outputs. The SY89809L is available in a single space saving package, enabling a lower overall cost solution.

APPLICATIONS

- High-performance PCs
- Workstations
- Parallel processor-based systems
- Other high-performance computing
- Communications

PIN NAMES

Pin	Function
HSTL_CLK, /HSTL_CLK	Differential HSTL Inputs
LVPECL_CLK, /LVPECL_CLK	Differential LVPECL Inputs
CLK_SEL	Input CLK Select (LVTTTL)
OE	Output Enable (LVTTTL)
Q ₀ -Q ₈ , /Q ₀ -/Q ₈	Differential HSTL Outputs
GND	Ground
V _{CCI}	V _{CC} Core
V _{CCO}	V _{CC} Output

LOGIC SYMBOL

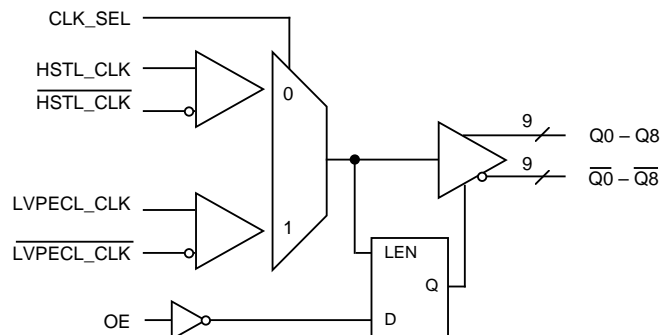

TRUTH TABLE

OE ⁽¹⁾	CLK_SEL	Q ₀ – Q ₈	/Q ₀ – /Q ₈
0	0	LOW	HIGH
0	1	LOW	HIGH
1	0	HSTL_CLK	/HSTL_CLK
1	1	LVPECL_CLK	/LVPECL_CLK

NOTE:

- The OE (output enable) signal is synchronized with the low level of the HSTL_CLK and LVPECL_CLK signal.

SIGNAL GROUPS

Level	Direction	Signal
HSTL	Input	HSTL_CLK, /HSTL_CLK
HSTL	Output	Q ₀ – Q ₈ , /Q ₀ – /Q ₈
LVPECL	Input	LVPECL_CLK, /LVPECL_CLK
LVCOS/LVTTL	Input	CLK_SEL, OE

ABSOLUTE MAXIMUM RATINGS⁽¹⁾

Symbol	Rating	Value	Unit
V _{CCI} , V _{CCO}	V _{CC} Pin Potential to Ground Pin	–0.5 to +4.0	V
V _{IN}	Input Voltage	–0.5 to V _{CCI}	V
I _{OUT}	DC Output Current (Output HIGH)	–50	mA
T _{store}	Storage Temperature	–65 to +150	°C

NOTE:

- Permanent device damage may occur if ABSOLUTE MAXIMUM RATINGS are exceeded. This is a stress rating only and functional operation is not implied at conditions other than those detailed in the operational sections of this data book. Exposure to ABSOLUTE MAXIMUM RATING conditions for extended periods may affect device reliability.

DC ELECTRICAL CHARACTERISTICS

Power Supply

Symbol	Parameter	T _A = 0°C			T _A = +25°C			T _A = +70°C			Unit
		Min.	Typ.	Max.	Min.	Typ.	Max.	Min.	Typ.	Max.	
V _{CCI}	V _{CC} Core	3.0	3.3	3.6	3.0	3.3	3.6	3.0	3.3	3.6	V
V _{CCO}	V _{CC} Output	1.6	1.8	2.0	1.6	1.8	2.0	1.6	1.8	2.0	V
I _{CCI}	I _{CC} Core	—	115	140	—	115	140	—	115	140	mA

HSTL

Symbol	Parameter	T _A = 0°C			T _A = +25°C			T _A = +70°C			Unit
		Min.	Typ.	Max.	Min.	Typ.	Max.	Min.	Typ.	Max.	
V _{OH}	Output HIGH Voltage ⁽¹⁾	1.0	—	1.2	1.0	—	1.2	1.0	—	1.2	V
V _{OL}	Output LOW Voltage ⁽¹⁾	0	—	0.4	0	—	0.4	0	—	0.4	V
V _{IH}	Input HIGH Voltage	V _X + 0.1	—	1.6	V _X + 0.1	—	1.6	V _X + 0.1	—	1.6	V
V _{IL}	Input LOW Voltage	–0.3	—	V _X – 0.1	–0.3	—	V _X – 0.1	–0.3	—	V _X – 0.1	V
V _X	Input Crossover Voltage	0.68	—	0.9	0.68	—	0.9	0.68	—	0.9	V
I _{IH}	Input HIGH Current	+20	—	–350	+20	—	–350	+20	—	–350	μA
I _{IL}	Input LOW Current	—	—	–500	—	—	–500	—	—	–500	μA

NOTE:

- Outputs loaded with 50Ω to ground.

DC ELECTRICAL CHARACTERISTICS

LVPECL

Symbol	Parameter	T _A = 0°C		T _A = +25°C		T _A = +70°C		Unit
		Min.	Max.	Min.	Max.	Min.	Max.	
V _{IH}	Input HIGH Voltage	V _{CCI} - 1.165	V _{CCI} - 0.880	V _{CCI} - 1.165	V _{CCI} - 0.880	V _{CCI} - 1.165	V _{CCI} - 0.880	V
V _{IL}	Input LOW Voltage	V _{CCI} - 1.810	V _{CCI} - 1.475	V _{CCI} - 1.810	V _{CCI} - 1.475	V _{CCI} - 1.810	V _{CCI} - 1.475	V
I _{IH}	Input HIGH Current	—	+150	—	+150	—	+150	μA
I _{IL}	Input LOW Current	0.5	—	0.5	—	0.5	—	μA

LVC MOS/LVTTL

Symbol	Parameter	T _A = 0°C			T _A = +25°C			T _A = +70°C			Unit
		Min.	Typ.	Max.	Min.	Typ.	Max.	Min.	Typ.	Max.	
V _{IH}	Input HIGH Voltage	2.0	—	—	2.0	—	—	2.0	—	—	V
V _{IL}	Input LOW Voltage	—	—	0.8	—	—	0.8	—	—	0.8	V
I _{IH}	Input HIGH Current	+20	—	-250	+20	—	-250	+20	—	-250	μA
I _{IL}	Input LOW Current	—	—	-600	—	—	-600	—	—	-600	μA

AC ELECTRICAL CHARACTERISTICS⁽¹⁾

Symbol	Parameter	T _A = 0°C			T _A = +25°C			T _A = +70°C			Unit
		Min.	Typ.	Max.	Min.	Typ.	Max.	Min.	Typ.	Max.	
t _{PHL} t _{PLH}	Propagation Delay ⁽²⁾	—	1.0	—	—	1.0	—	—	1.0	—	ns
f _{MAX}	Maximum Operating Freq. ⁽³⁾	500	—	—	500	—	—	500	—	—	MHz
t _{skew}	Within-Device Skew ⁽⁴⁾	—	—	50	—	—	50	—	—	50	ps
t _{skpp}	Part-to-Part Skew ⁽⁵⁾	—	—	200	—	—	200	—	—	200	ps
V _{PP}	Minimum Input Swing ⁽⁶⁾ LVPECL_CLK	600	—	—	600	—	—	600	—	—	mV
V _{CMR}	Common Mode Range ⁽⁷⁾ LVPECL_CLK	-1.5	—	-0.4	-1.5	—	-0.4	-1.5	—	-0.4	V
t _S	OE Set-Up Time ⁽⁸⁾	1.0	—	—	1.0	—	—	1.0	—	—	ns
t _H	OE Hold Time	0.5	—	—	0.5	—	—	0.5	—	—	ns
t _r t _f	Output Rise/Fall Time (20% – 80%)	300	—	800	300	—	800	300	—	800	ps

NOTES:

1. Outputs loaded with 50Ω to ground. Airflow ≥ 300 LFPM.
2. Differential propagation delay is defined as the delay from the crossing point of the differential input signals to the crossing point of the differential output signals.
3. Output swing greater than 450mV.
4. The within-device skew is defined as the worst case difference between any two similar delay paths within a single device operating at the same voltage and temperature.
5. The part-to-part skew is defined as the absolute worst case difference between any two delay paths on any two devices operating at the same voltage and temperature.
6. The V_{PP} (min.) is defined as the minimum input differential voltage which will cause no increase in the propagation delay.
7. V_{CMR} is defined as the range within which the V_{IH} level may vary, with the device still meeting the propagation delay specification. The numbers in the table are referenced to V_{CCI}. The V_{IL} level must be such that the peak-to-peak voltage is less than 1.0V and greater than or equal to V_{PP} (min.). The lower end of the CMR range varies 1:1 with V_{CCI}. The V_{CMR} (min) will be fixed at 3.3V - |V_{CMR} (min)|.
8. OE set-up time is defined with respect to the rising edge of the clock. OE HIGH-to-LOW transition ensures outputs remain disabled during the next clock cycle. OE LOW-to-HIGH transition enables normal operation of the next input clock.

PRODUCT ORDERING CODE

Ordering Code	Package Type	Operating Range
SY89809LTC	T32-1	Commercial

32 LEAD TQFP (T32-1)

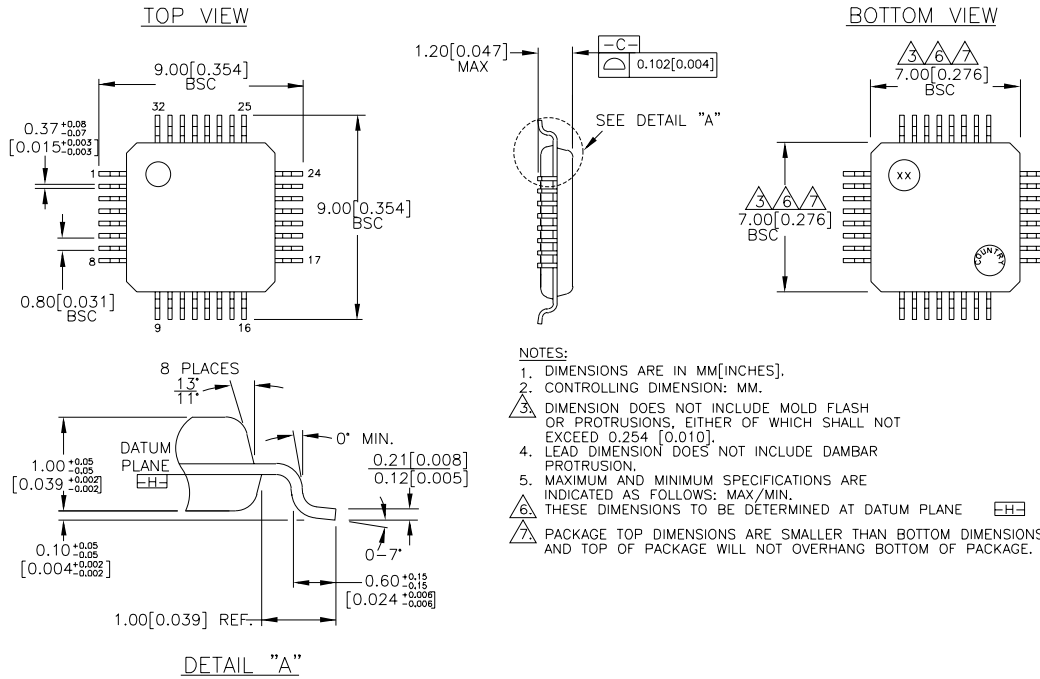

MICREL-SYNERGY 3250 SCOTT BOULEVARD SANTA CLARA CA 95054 USA

TEL + 1 (408) 980-9191 FAX + 1 (408) 914-7878 WEB <http://www.micrel.com>

This information is believed to be accurate and reliable, however no responsibility is assumed by Micrel for its use nor for any infringement of patents or other rights of third parties resulting from its use. No license is granted by implication or otherwise under any patent or patent right of Micrel Inc.

© 2000 Micrel Incorporated