

Voltage Regulator

Key Features

- Vbat monitor with fault signal generation when Vbat is out of operative range
- Vdd monitor with intelligent reset generation based on Vdd level
- Internal protections against transients up to 40V
- Over-temperature monitor
- Power down mode

General Description

This block provides a stable regulated output voltage starting from a battery input with the maximum current load allowed by the thermal package limitation (worst case 20mA). Higher current can be delivered using an external NPN transistor. External capacitors are required on the regulated line (VDD) and the battery supply voltage (VBAT). Battery input is monitored and a fault signal becomes active when VBAT is out of its operative range (an hysteresis is provided). VDD also is monitored and a fault signal becomes active when VDD is below a defined voltage threshold (an hysteresis is provided). Internal protections are designed to handle transients up to 40V. An external 45V zener diode between VBAT and ground with a 500Ω resistor in series with the battery supply and the VBAT pin is required to protect the device from power transients. An external blocking diode is required to provide reverse battery protection. Over-temperature monitor turns off the circuit when the die temperature exceeds the fixed threshold. The circuit has a power-down mode to permit very low standby currents.

Typical Application Diagrams

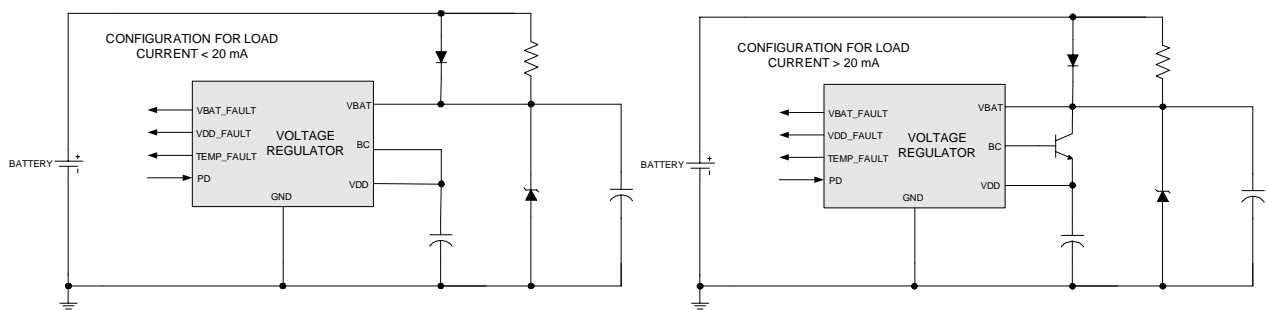

Key Parameters	Symbol	Min.	Max.	Notes
Battery Supply Voltage	VBAT	7V	18V	Load dump 42V.
Output Voltage	VDD	4.75V	5.25V	Recommended external capacitor $\geq 100\text{nF}$. 20mA max. load, higher current with external transistor.
Temperature Threshold	Toff	160°C		Hysteresis >10 degrees
Ambient Temperature	Tamb	-40°C	85°C	

For detailed information:

info@austriamicrosystems.com

<http://www.austriamicrosystems.com/>

Copyright © 2003 austriamicrosystems. Trademarks registered ®. All rights reserved. The material herein may not be reproduced, adapted, merged, translated, stored, or used without the prior written consent of the copyright owner. To the best of its knowledge, austriamicrosystems asserts that the information contained in this publication is accurate and correct.