



**USE ULTRA3700™ FOR  
ALL NEW DESIGNS**

**CY7C346**

# 128-Macrocell MAX® EPLD

## Features

- 128 macrocells in eight logic array blocks (LABs)
- 20 dedicated inputs, up to 64 bidirectional I/O pins
- Programmable interconnect array
- 0.8-micron double-metal CMOS EPROM technology
- Available in 84-pin CLCC, PLCC, and 100-pin PGA, PQFP

## Functional Description

The CY7C346 is an Erasable Programmable Logic Device (EPLD) in which CMOS EPROM cells are used to configure logic functions within the device. The MAX® architecture is 100% user-configurable, allowing the device to accommodate a variety of independent logic functions.

The 128 macrocells in the CY7C346 are divided into eight LABs, 16 per LAB. There are 256 expander product terms, 32 per LAB, to be used and shared by the macrocells within each LAB.

Each LAB is interconnected through the programmable interconnect array, allowing all signals to be routed throughout the chip.

The speed and density of the CY7C346 allow it to be used in a wide range of applications, from replacement of large amounts of 7400-series TTL logic, to complex controllers and multifunction chips. With greater than 25 times the functionality of 20-pin PLDs, the CY7C346 allows the replacement of over 50 TTL devices. By replacing large amounts of logic, the CY7C346 reduces board space, part count, and increases system reliability.

## Logic Block Diagram

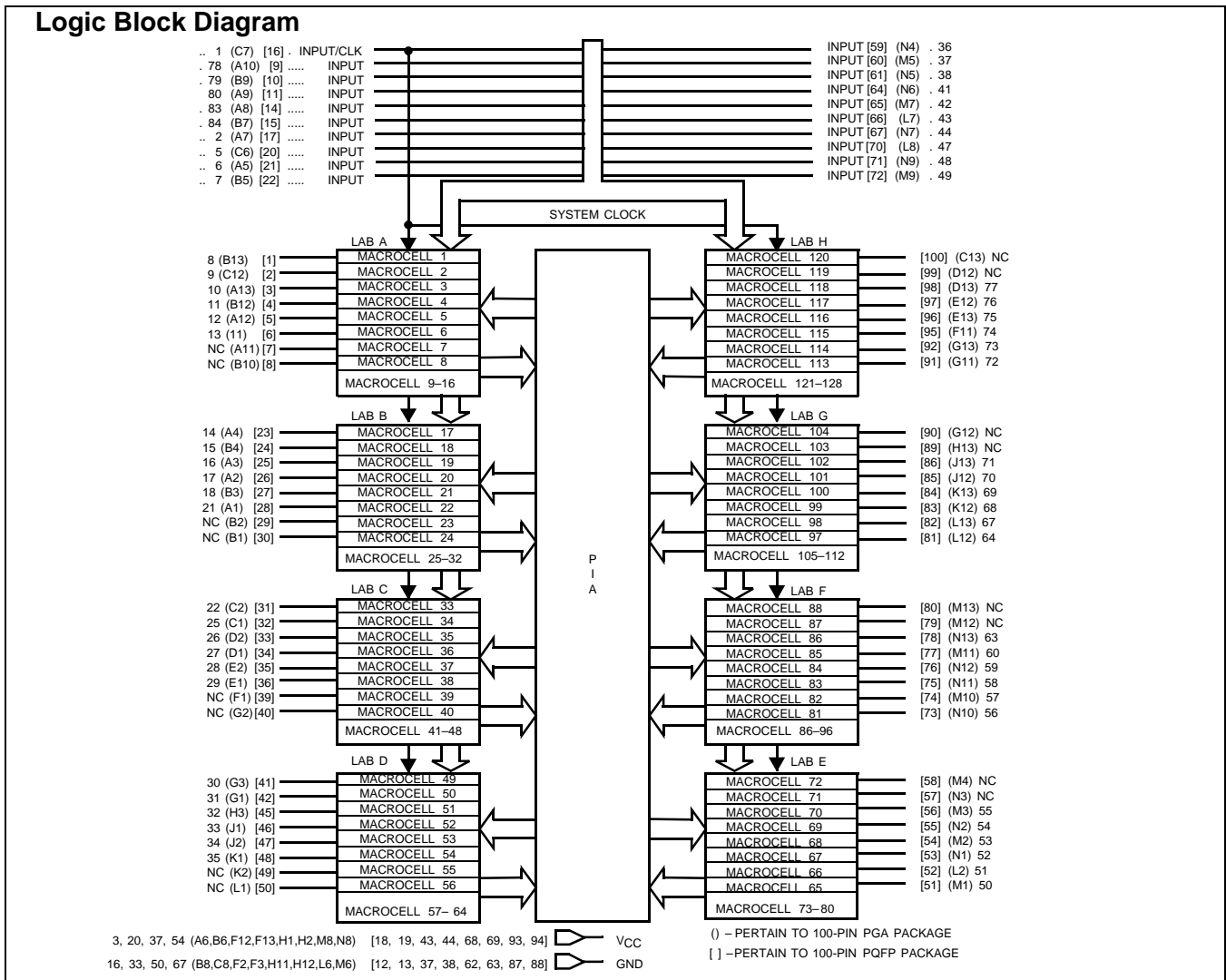

**Selection Guide**

		<b>7C346-25</b>	<b>7C346-30</b>	<b>7C346-35</b>	<b>Unit</b>
Maximum Access Time		25	30	35	ns
Maximum Operating Current	Commercial	250	250	250	mA
	Military	325	320	320	
	Industrial	320	320	320	
Maximum Standby Current	Commercial	225	225	225	mA
	Military	275	275	275	
	Industrial	275	275	275	

**Pin Configurations**

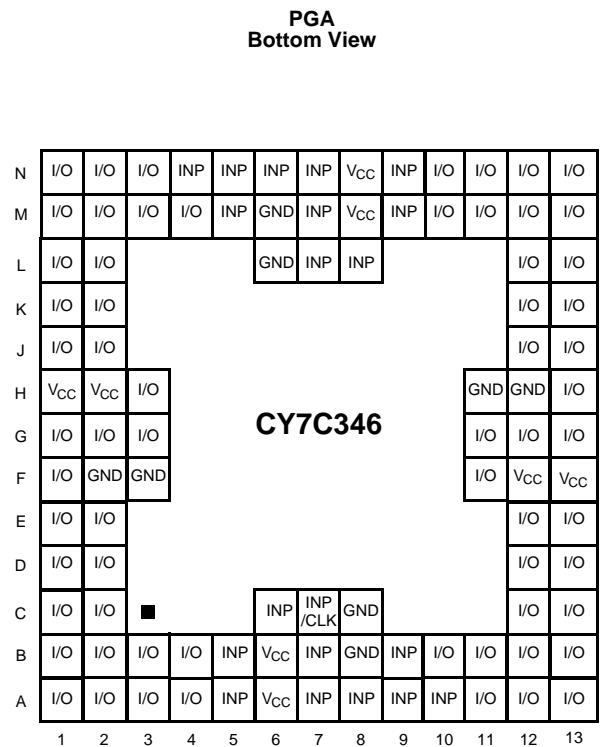
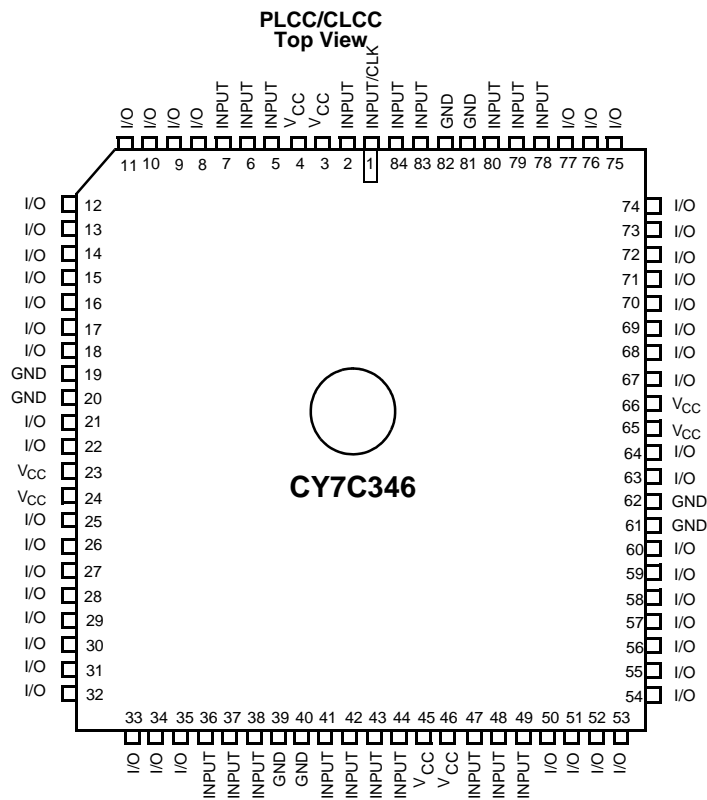

**Pin Configurations** (continued)

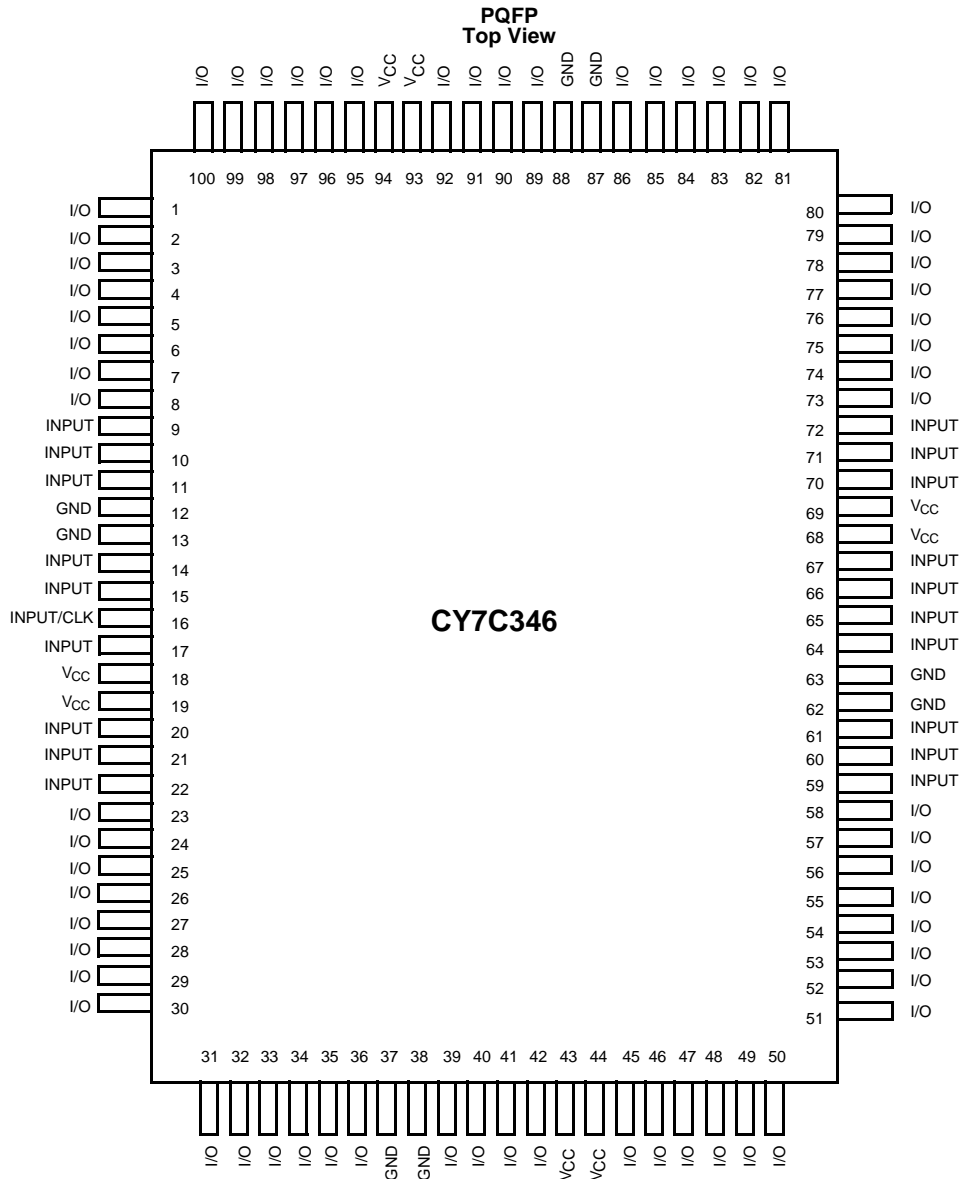

## Logic Array Blocks

There are eight logic array blocks in the CY7C346. Each LAB consists of a macrocell array containing 16 macrocells, an expander product term array containing 32 expanders, and an I/O block. The LAB is fed by the programmable interconnect array and the dedicated input bus. All macrocell feedbacks go to the macrocell array, the expander array, and the programmable interconnect array. Expanders feed themselves and the macrocell array. All I/O feedbacks go to the programmable interconnect array so that they may be accessed by macrocells in other LABs as well as the macrocells in the LAB in which they are situated.

Externally, the CY7C346 provides 20 dedicated inputs, one of which may be used as a system clock. There are 64 I/O pins

that may be individually configured for input, output, or bidirectional data flow.

## Programmable Interconnect Array

The Programmable Interconnect Array (PIA) solves interconnect limitations by routing only the signals needed by each logic array block. The inputs to the PIA are the outputs of every macrocell within the device and the I/O pin feedback of every pin on the device.

## Timing Delays

Timing delays within the CY7C346 may be easily determined using *Warp*®, *Warp Professional*™, or *Warp Enterprise*™ software. The CY7C346 has fixed internal delays, allowing the user to determine the worst case timing delays for any design.

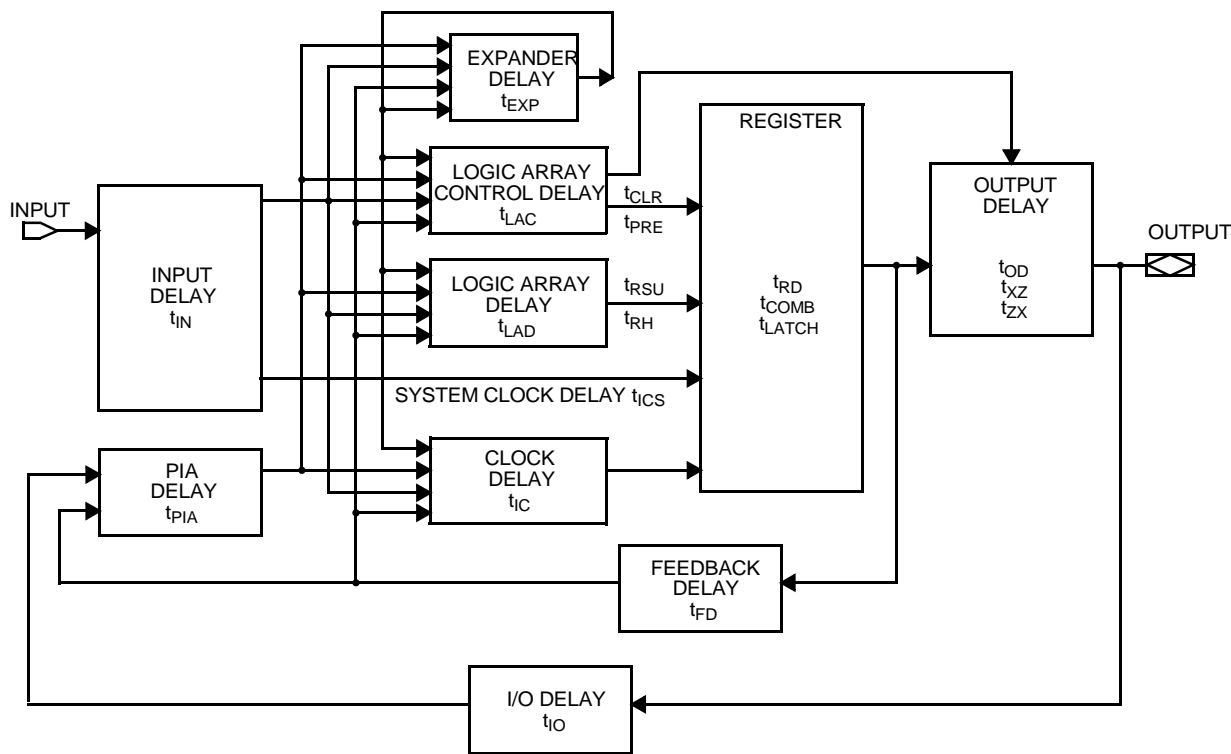

**Figure 1. CY7C346 Internal Timing Model**

## Design Recommendations

Operation of the devices described herein with conditions above those listed under "Maximum Ratings" may cause permanent damage to the device. This is a stress rating only and functional operation of the device at these or any other conditions above those indicated in the operational sections of this data sheet is not implied. Exposure to absolute maximum ratings conditions for extended periods of time may affect device reliability. The CY7C346 contains circuitry to protect device pins from high static voltages or electric fields, but normal precautions should be taken to avoid application of any voltage higher than the maximum rated voltages.

For proper operation, input and output pins must be constrained to the range  $GND \leq (V_{IN} \text{ or } V_{OUT}) \leq V_{CC}$ . Unused inputs must always be tied to an appropriate logic level

(either  $V_{CC}$  or GND). Each set of  $V_{CC}$  and GND pins must be connected together directly at the device. Power supply decoupling capacitors of at least 0.2  $\mu F$  must be connected between  $V_{CC}$  and GND. For the most effective decoupling, each  $V_{CC}$  pin should be separately decoupled to GND directly at the device. Decoupling capacitors should have good frequency response, such as monolithic ceramic types have.

## Design Security

The CY7C346 contains a programmable design security feature that controls the access to the data programmed into the device. If this programmable feature is used, a proprietary design implemented in the device cannot be copied or retrieved. This enables a high level of design control to be

obtained since programmed data within EPROM cells is invisible. The bit that controls this function, along with all other program data, may be reset simply by erasing the entire device.

The CY7C346 is fully functionally tested and guaranteed through complete testing of each programmable EPROM bit and all internal logic elements thus ensuring 100% programming yield.

The erasable nature of these devices allows test programs to be used and erased during early stages of the production flow. The devices also contain on-board logic test circuitry to allow verification of function and AC specification once encapsulated in non-windowed packages.

**Typical  $I_{CC}$  vs.  $f_{MAX}$**

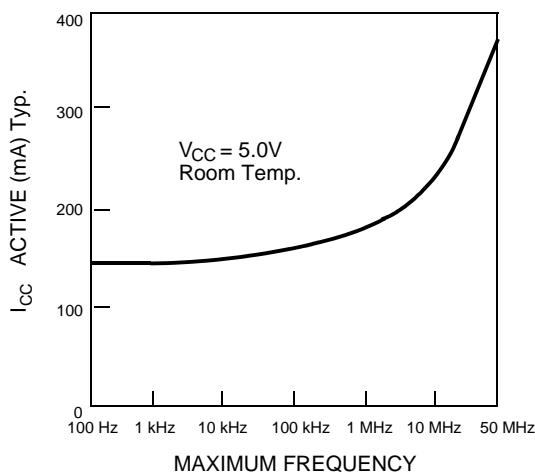

**Output Drive Current**

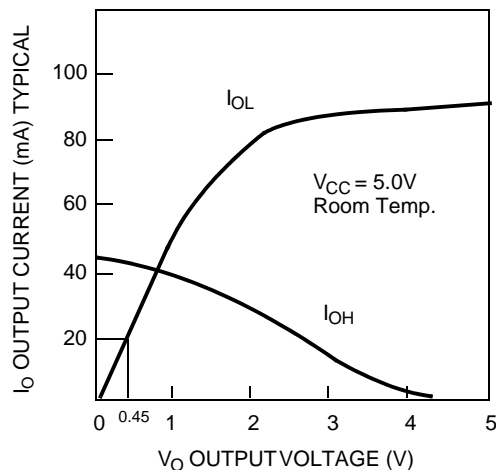

**Timing Considerations**

Unless otherwise stated, propagation delays do not include expanders. When using expanders, add the maximum expander delay  $t_{EXP}$  to the overall delay. Similarly, there is an additional  $t_{PIA}$  delay for an input from an I/O pin when compared to a signal from straight input pin.

When calculating synchronous frequencies, use  $t_{S1}$  if all inputs are on dedicated input pins. The parameter  $t_{S2}$  should be used if data is applied at an I/O pin. If  $t_{S2}$  is greater than  $t_{CO1}$ ,  $1/t_{S2}$  becomes the limiting frequency in the data path mode unless  $1/(t_{WH} + t_{WL})$  is less than  $1/t_{S2}$ .

When expander logic is used in the data path, add the appropriate maximum expander delay,  $t_{EXP}$  to  $t_{S1}$ . Determine which of  $1/(t_{WH} + t_{WL})$ ,  $1/t_{CO1}$ , or  $1/(t_{EXP} + t_{S1})$  is the lowest frequency. The lowest of these frequencies is the maximum data path frequency for the synchronous configuration.

When calculating external asynchronous frequencies, use  $t_{AS1}$  if all inputs are on the dedicated input pins. If any data is applied to an I/O pin,  $t_{AS2}$  must be used as the required set-up time. If  $(t_{AS2} + t_{AH})$  is greater than  $t_{ACO1}$ ,  $1/(t_{AS2} + t_{AH})$  becomes the limiting frequency in the data path mode unless  $1/(t_{AWH} + t_{AWL})$  is less than  $1/(t_{AS2} + t_{AH})$ .

When expander logic is used in the data path, add the appropriate maximum expander delay,  $t_{EXP}$  to  $t_{AS1}$ . Determine which of  $1/(t_{AWH} + t_{AWL})$ ,  $1/t_{ACO1}$ , or  $1/(t_{EXP} + t_{AS1})$  is the lowest frequency. The lowest of these frequencies is the maximum data path frequency for the asynchronous configuration.

The parameter  $t_{OH}$  indicates the system compatibility of this device when driving other synchronous logic with positive input hold times, which is controlled by the same synchronous clock. If  $t_{OH}$  is greater than the minimum required input hold time of the subsequent synchronous logic, then the devices are guaranteed to function properly with a common synchronous clock under worst-case environmental and supply voltage conditions.

The parameter  $t_{AOH}$  indicates the system compatibility of this device when driving subsequent registered logic with a positive hold time and using the same asynchronous clock as the CY7C346.

In general, if  $t_{AOH}$  is greater than the minimum required input hold time of the subsequent logic (synchronous or asynchronous) then the devices are guaranteed to function properly under worst-case environmental and supply voltage conditions, provided the clock signal source is the same. This also applies if expander logic is used in the clock signal path of the driving device, but not for the driven device. This is due to the expander logic in the second device's clock signal path adding an additional delay ( $t_{EXP}$ ) causing the output data from the preceding device to change prior to the arrival of the clock signal at the following device's register.



**Maximum Ratings**

(Above which the useful life may be impaired. For user guidelines, not tested.)

- Storage Temperature ..... -65°C to +150°C
- Ambient Temperature with Power Applied..... -55°C to +125°C
- Maximum Junction Temperature (under bias)..... 150°C
- Supply Voltage to Ground Potential ..... -2.0V to +7.0V
- Maximum Power Dissipation..... 2500 mW
- DC V<sub>CC</sub> or GND Current ..... 500 mA

- DC Output Current per Pin ..... -25 mA to +25 mA
- DC Input Voltage<sup>[1]</sup> ..... -3.0V to +7.0V
- DC Program Voltage..... 13.0V
- Static Discharge Voltage..... > 1100V (per MIL-STD-883, Method 3015)

**Operating Range**

Range	Ambient Temperature	V <sub>CC</sub>
Commercial	0°C to +70°C	5V ± 5%
Industrial	-40°C to +85°C	5V ± 10%
Military	-55°C to +125°C (Case)	5V ± 10%

**Electrical Characteristics Over the Operating Range<sup>[2]</sup>**

Parameter	Description	Test Conditions	Min.	Max.	Unit
V <sub>OH</sub>	Output HIGH Voltage	V <sub>CC</sub> = Min., I <sub>OH</sub> = -4.0 mA	2.4		V
V <sub>OL</sub>	Output LOW Voltage	V <sub>CC</sub> = Min., I <sub>OL</sub> = 8.0 mA		0.45	V
V <sub>IH</sub>	Input HIGH Voltage		2.2	V <sub>CC</sub> + 0.3	V
V <sub>IL</sub>	Input LOW Voltage		-0.3	0.8	V
I <sub>IX</sub>	Input Current	GND ≤ V <sub>IN</sub> ≤ V <sub>CC</sub>	-10	+10	μA
I <sub>OZ</sub>	Output Leakage Current	V <sub>O</sub> = V <sub>CC</sub> or GND	-40	+40	μA
I <sub>OS</sub>	Output Short Circuit Current	V <sub>CC</sub> = Max., V <sub>OUT</sub> = 0.5V <sup>[3, 4]</sup>	-30	-90	mA
I <sub>CC1</sub>	Power Supply Current (Standby)	V <sub>I</sub> = GND (No Load)		225	mA
		Commercial		275	
I <sub>CC2</sub>	Power Supply Current <sup>[5]</sup>	V <sub>I</sub> = V <sub>CC</sub> or GND (No Load) f = 1.0 MHz <sup>[4]</sup>		250	mA
		Commercial		320	
t <sub>R</sub>	Recommended Input Rise Time			100	ns
t <sub>F</sub>	Recommended Input Fall Time			100	ns

**Capacitance<sup>[6]</sup>**

Parameter	Description	Test Conditions	Max.	Unit
C <sub>IN</sub>	Input Capacitance	V <sub>IN</sub> = 2V, f = 1.0 MHz	10	pF
C <sub>OUT</sub>	Output Capacitance	V <sub>OUT</sub> = 2V, f = 1.0 MHz	20	pF

**AC Test Loads and Waveforms<sup>[6]</sup>**

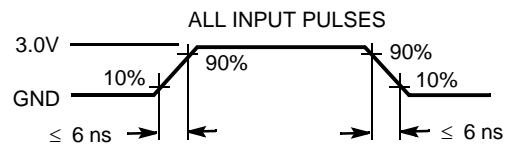
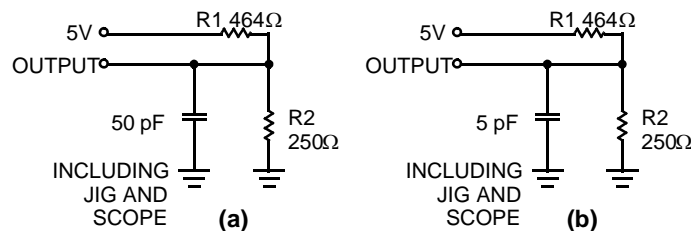

Equivalent to: THÉVENIN EQUIVALENT (Commercial/Military)

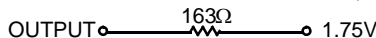

**Notes:**

1. Minimum DC input is -0.3V. During transitions, the inputs may undershoot to -3.0V for periods less than 20 ns.
2. Typical values are for T<sub>A</sub> = 25°C and V<sub>CC</sub> = 5V.
3. Not more than one output should be tested at a time. Duration of the short circuit should not be more than one second. V<sub>OUT</sub> = 0.5V has been chosen to avoid test problems caused by tester ground degradation.
4. Guaranteed by design but not 100% tested.
5. This parameter is measured with device programmed as a 16-bit counter in each LAB.
6. Part (a) in AC Test Load and Waveforms is used for all parameters except t<sub>ER</sub> and t<sub>XZ</sub>, which is used for part (b) in AC Test Load and Waveforms. All external timing parameters are measured referenced to external pins of the device.



**Commercial and Industrial External Synchronous Switching Characteristics<sup>[6]</sup> Over Operating Range**

Parameter	Description	7C346-25		7C346-30		7C346-35		Unit
		Min.	Max.	Min.	Max.	Min.	Max.	
t <sub>PD1</sub>	Dedicated Input to Combinatorial Output Delay <sup>[7]</sup>		25		30		35	ns
t <sub>PD2</sub>	I/O Input to Combinatorial Output Delay <sup>[10]</sup>		40		45		55	ns
t <sub>PD3</sub>	Dedicated Input to Combinatorial Output Delay with Expander Delay <sup>[11]</sup>		37		44		55	ns
t <sub>PD4</sub>	I/O Input to Combinatorial Output Delay with Expander Delay <sup>[4, 12]</sup>		52		59		75	ns
t <sub>EA</sub>	Input to Output Enable Delay <sup>[4, 7]</sup>		25		30		35	ns
t <sub>ER</sub>	Input to Output Disable Delay <sup>[4, 7]</sup>		25		30		35	ns
t <sub>CO1</sub>	Synchronous Clock Input to Output Delay		14		16		20	ns
t <sub>CO2</sub>	Synchronous Clock to Local Feedback to Combinatorial Output <sup>[4, 13]</sup>		30		35		42	ns
t <sub>S1</sub>	Dedicated Input or Feedback Set-Up Time to Synchronous Clock Input <sup>[7, 14]</sup>	15		20		25		ns
t <sub>S2</sub>	I/O Input Set-Up Time to Synchronous Clock Input <sup>[7]</sup>	30		36		45		ns
t <sub>H</sub>	Input Hold Time from Synchronous Clock Input <sup>[7]</sup>	0		0		0		ns
t <sub>WH</sub>	Synchronous Clock Input HIGH Time	8		10		12.5		ns
t <sub>WL</sub>	Synchronous Clock Input LOW Time	8		10		12.5		ns
t <sub>RW</sub>	Asynchronous Clear Width <sup>[4, 7]</sup>	25		30		35		ns
t <sub>RR</sub>	Asynchronous Clear Recovery Time <sup>[4, 7]</sup>	25		30		35		ns
t <sub>RO</sub>	Asynchronous Clear to Registered Output Delay <sup>[7]</sup>		25		30		35	ns
t <sub>PW</sub>	Asynchronous Preset Width <sup>[4, 7]</sup>	25		30		35		ns
t <sub>PR</sub>	Asynchronous Preset Recovery Time <sup>[4, 7]</sup>	25		30		35		ns
t <sub>PO</sub>	Asynchronous Preset to Registered Output Delay <sup>[7]</sup>		25		30		35	ns
t <sub>CF</sub>	Synchronous Clock to Local Feedback Input <sup>[4, 15]</sup>		3		3		6	ns
t <sub>P</sub>	External Synchronous Clock Period (1/(f <sub>MAX3</sub> ) <sup>[4]</sup> )	16		20		25		ns
f <sub>MAX1</sub>	External Feedback Maximum Frequency (1/(t <sub>CO1</sub> + t <sub>S1</sub> ) <sup>[4, 16]</sup> )	34.5		27.7		22.2		MHz
f <sub>MAX2</sub>	Internal Local Feedback Maximum Frequency, lesser of (1/(t <sub>S1</sub> + t <sub>CF</sub> )) or (1/t <sub>CO1</sub> ) <sup>[4, 17]</sup>	55.5		43.4		32.2		MHz
f <sub>MAX3</sub>	Data Path Maximum Frequency, lesser of (1/(t <sub>WL</sub> + t <sub>WH</sub> )), (1/(t <sub>S1</sub> + t <sub>H</sub> )) or (1/t <sub>CO1</sub> ) <sup>[4, 18]</sup>	62.5		50		40		MHz
f <sub>MAX4</sub>	Maximum Register Toggle Frequency (1/(t <sub>WL</sub> + t <sub>WH</sub> ) <sup>[4, 19]</sup> )	62.5		50		40		MHz
t <sub>OH</sub>	Output Data Stable Time from Synchronous Clock Input <sup>[4, 20]</sup>	3		3		3		ns

**Notes:**

7. This specification is a measure of the delay from input signal applied to a dedicated input (68-pin PLCC input pin 1, 2, 32, 34, 35, 66, or 68) to combinatorial output on any output pin. This delay assumes no expander terms are used to form the logic function.
8. When this note is applied to any parameter specification it indicates that the signal (data, asynchronous clock, asynchronous clear, and/or asynchronous preset) is applied to a dedicated input only and no signal path (either clock or data) employs expander logic.
9. If an input signal is applied to an I/O pin an additional delay equal to t<sub>PIA</sub> should be added to the comparable delay for a dedicated input. If expanders are used, add the maximum expander delay t<sub>EXP</sub> to the overall delay for the comparable delay without expanders.
10. This specification is a measure of the delay from input signal applied to an I/O macrocell pin to any output. This delay assumes no expander terms are used to form the logic function.
11. This specification is a measure of the delay from an input signal applied to a dedicated input (68-pin PLCC input pin 1, 2, 32, 34, 35, 66, or 68) to combinatorial output on any output pin. This delay assumes expander terms are used to form the logic function and includes the worst-case expander logic delay for one pass through the expander logic.
12. This specification is a measure of the delay from an input signal applied to an I/O macrocell pin to any output. This delay assumes expander terms are used to form the logic function and includes the worst-case expander logic delay for one pass through the expander logic. This parameter is tested periodically by sampling production material.
13. This specification is a measure of the delay from synchronous register clock to internal feedback of the register output signal to the input of the LAB logic array and then to a combinatorial output. This delay assumes no expanders are used, register is synchronously clocked and all feedback is within the same LAB. This parameter is tested periodically by sampling production material.
14. If data is applied to an I/O input for capture by a macrocell register, the I/O pin input set-up time minimums should be observed. These parameters are t<sub>S2</sub> for synchronous operation and t<sub>AS2</sub> for asynchronous operation.
15. This specification is a measure of the delay associated with the internal register feedback path. This is the delay from synchronous clock to LAB logic array input. This delay plus the register set-up time, t<sub>S1</sub>, is the minimum internal period for an internal synchronous state machine configuration. This delay is for feedback within the same LAB. This parameter is tested periodically by sampling production material.
16. This specification indicates the guaranteed maximum frequency, in synchronous mode, at which a state machine configuration with external feedback can operate. It is assumed that all data inputs and external feedback signals are applied to dedicated inputs.
17. This specification indicates the guaranteed maximum frequency at which a state machine with internal-only feedback can operate. If register output states must also control external points, this frequency can still be observed as long as this frequency is less than 1/t<sub>CO1</sub>. All feedback is assumed to be local originating within the same LAB.
18. This frequency indicates the maximum frequency at which the device may operate in data path mode (dedicated input pin to output pin). This assumes data input signals are applied to dedicated input pins and no expander logic is used. If any of the data inputs are I/O pins, t<sub>S2</sub> is the appropriate t<sub>S</sub> for calculation.
19. This specification indicates the guaranteed maximum frequency, in synchronous mode, at which an individual output or buried register can be cycled by a clock signal applied to the dedicated clock input pin.
20. This parameter indicates the minimum time after a synchronous register clock input that the previous register output data is maintained on the output pin. This specification is a measure of the delay from an asynchronous register clock input to internal feedback of the register output signal to the input of the LAB logic array and then to a combinatorial output. This delay assumes no expanders are used in the logic of combinatorial output or the asynchronous clock input. The clock signal is applied to the dedicated clock input pin and all feedback is within a single LAB. This parameter is tested periodically by sampling production material.





**Commercial and Industrial External Asynchronous Switching Characteristics<sup>[6]</sup> Over Operating Range**

Parameter	Description	7C346-25		7C346-30		7C346-35		Unit
		Min.	Max.	Min.	Max.	Min.	Max.	
t <sub>ACO1</sub>	Asynchronous Clock Input to Output Delay <sup>[7]</sup>		25		30		35	ns
t <sub>ACO2</sub>	Asynchronous Clock Input to Local Feedback to Combinatorial Output <sup>[20]</sup>		39		46		55	ns
t <sub>AS1</sub>	Dedicated Input or Feedback Set-Up Time to Asynchronous Clock Input <sup>[7]</sup>	5		6		8		ns
t <sub>AS2</sub>	I/O Input Set-Up Time to Asynchronous Clock Input <sup>[7]</sup>	19		22		28		ns
t <sub>AH</sub>	Input Hold Time from Asynchronous Clock Input <sup>[7]</sup>	6		8		10		ns
t <sub>AWH</sub>	Asynchronous Clock Input HIGH Time <sup>[7]</sup>	11		14		16		ns
t <sub>AWL</sub>	Asynchronous Clock Input LOW Time <sup>[7, 21]</sup>	9		11		14		ns
t <sub>ACF</sub>	Asynchronous Clock to Local Feedback Input <sup>[4, 22]</sup>		15		18		22	ns
t <sub>AP</sub>	External Asynchronous Clock Period (1/(f <sub>MAXA4</sub> )) <sup>[4]</sup>	20		25		30		ns
f <sub>MAXA1</sub>	External Feedback Maximum Frequency in Asynchronous Mode (1/(t <sub>ACO1</sub> + t <sub>AS1</sub> )) <sup>[4, 23]</sup>	33.3		27.7		23.2		MHz
f <sub>MAXA2</sub>	Maximum Internal Asynchronous Frequency <sup>[4, 24]</sup>	50		40		33.3		MHz
f <sub>MAXA3</sub>	Data Path Maximum Frequency in Asynchronous Mode <sup>[4, 25]</sup>	40		33.3		28.5		MHz
f <sub>MAXA4</sub>	Maximum Asynchronous Register Toggle Frequency 1/(t <sub>AWH</sub> + t <sub>AWL</sub> ) <sup>[4, 26]</sup>	50		40		33.3		MHz
t <sub>AOH</sub>	Output Data Stable Time from Asynchronous Clock Input <sup>[4, 27]</sup>	15		15		15		ns

**Notes:**

21. This parameter is measured with a positive-edge triggered clock at the register. For negative edge triggering, the t<sub>AWH</sub> and t<sub>AWL</sub> parameters must be swapped. If a given input is used to clock multiple registers with both positive and negative polarity, t<sub>AWH</sub> should be used for both t<sub>AWH</sub> and t<sub>AWL</sub>.
22. This specification is a measure of the delay associated with the internal register feedback path for an asynchronous clock to LAB logic array input. This delay plus the asynchronous register set-up time, t<sub>AS1</sub>, is the minimum internal period for an internal asynchronously clocked state machine configuration. This delay is for feedback within the same LAB, assumes no expander logic in the clock path, and assumes that the clock input signal is applied to a dedicated input pin. This parameter is tested periodically by sampling production material.
23. This specification indicates the guaranteed maximum frequency at which an asynchronously clocked state machine configuration with external feedback can operate. It is assumed that all data inputs, clock inputs, and feedback signals are applied to dedicated inputs and that no expander logic is employed in the clock signal path or data path.
24. This specification indicates the guaranteed maximum frequency at which an asynchronously clocked state machine with internal-only feedback can operate. This parameter is determined by the lesser of (1/(t<sub>ACF</sub> + t<sub>AS1</sub>)) or (1/(t<sub>AWH</sub> + t<sub>AWL</sub>)). If register output states must also control external points, this frequency can still be observed as long as this frequency is less than 1/t<sub>ACO1</sub>. This specification assumes no expander logic is utilized, all data inputs and clock inputs are applied to dedicated inputs, and all state feedback is within a single LAB. This parameter is tested periodically by sampling production material.
25. This frequency is the maximum frequency at which the device may operate in the asynchronously clocked data path mode. This specification is determined by the lesser of 1/(t<sub>AWH</sub> + t<sub>AWL</sub>), 1/(t<sub>AS1</sub> + t<sub>AH</sub>) or 1/t<sub>ACO1</sub>. It assumes data and clock input signals are applied to dedicated input pins and no expander logic is used.
26. This specification indicates the guaranteed maximum frequency at which an individual output or buried register can be cycled in asynchronously clocked mode by a clock signal applied to an external dedicated input pin.
27. This parameter indicates the minimum time that the previous register output data is maintained on the output after an asynchronous register clock input applied to an external dedicated input pin.





**Commercial and Industrial Internal Switching Characteristics** Over Operating Range

Parameter	Description	7C346-25		7C346-30		7C346-35		Unit
		Min.	Max.	Min.	Max.	Min.	Max.	
t <sub>IN</sub>	Dedicated Input Pad and Buffer Delay		5		7		9	ns
t <sub>IO</sub>	I/O Input Pad and Buffer Delay		6		6		9	ns
t <sub>EXP</sub>	Expander Array Delay		12		14		20	ns
t <sub>LAD</sub>	Logic Array Data Delay		12		14		16	ns
t <sub>LAC</sub>	Logic Array Control Delay		10		12		13	ns
t <sub>OD</sub>	Output Buffer and Pad Delay		5		5		6	ns
t <sub>ZX</sub>	Output Buffer Enable Delay <sup>[28]</sup>		10		11		13	ns
t <sub>XZ</sub>	Output Buffer Disable Delay		10		11		13	ns
t <sub>RSU</sub>	Register Set-Up Time Relative to Clock Signal at Register	6		8		10		ns
t <sub>RH</sub>	Register Hold Time Relative to Clock Signal at Register	6		8		10		ns
t <sub>LATCH</sub>	Flow Through Latch Delay		3		4		4	ns
t <sub>RD</sub>	Register Delay		1		2		2	ns
t <sub>COMB</sub>	Transparent Mode Delay <sup>[29]</sup>		3		4		4	ns
t <sub>CH</sub>	Clock HIGH Time	8		10		12.5		ns
t <sub>CL</sub>	Clock LOW Time	8		10		12.5		ns
t <sub>IC</sub>	Asynchronous Clock Logic Delay		14		16		18	ns
t <sub>ICS</sub>	Synchronous Clock Delay		1		1		1	ns
t <sub>FD</sub>	Feedback Delay		1		1		2	ns
t <sub>PRE</sub>	Asynchronous Register Preset Time		5		6		7	ns
t <sub>CLR</sub>	Asynchronous Register Clear Time		5		6		7	ns
t <sub>PCW</sub>	Asynchronous Preset and Clear Pulse Width	5		6		7		ns
t <sub>PCR</sub>	Asynchronous Preset and Clear Recovery Time	5		6		7		ns
t <sub>PIA</sub>	Programmable Interconnect Array Delay Time		14		16		20	ns

**Notes:**

28. Sample tested only for an output change of 500 mV.

29. This specification guarantees the maximum combinatorial delay associated with the macrocell register bypass when the macrocell is configured for combinatorial operation.



**Military External Synchronous Switching Characteristics<sup>[6]</sup> Over Operating Range**

Parameter	Description	7C346-30		7C346-35		Unit
		Min.	Max.	Min.	Max.	
t <sub>PD1</sub>	Dedicated Input to Combinatorial Output Delay <sup>[7]</sup>		30		35	ns
t <sub>PD2</sub>	I/O Input to Combinatorial Output Delay <sup>[10]</sup>		45		55	ns
t <sub>PD3</sub>	Dedicated Input to Combinatorial Output Delay with Expander Delay <sup>[11]</sup>		44		55	ns
t <sub>PD4</sub>	I/O Input to Combinatorial Output Delay with Expander Delay <sup>[4, 12]</sup>		59		75	ns
t <sub>EA</sub>	Input to Output Enable Delay <sup>[4, 7]</sup>		30		35	ns
t <sub>ER</sub>	Input to Output Disable Delay <sup>[4, 7]</sup>		30		35	ns
t <sub>CO1</sub>	Synchronous Clock Input to Output Delay		16		20	ns
t <sub>CO2</sub>	Synchronous Clock to Local Feedback to Combinatorial Output <sup>[4, 13]</sup>		35		42	ns
t <sub>S1</sub>	Dedicated Input or Feedback Set-Up Time to Synchronous Clock Input <sup>[7, 14]</sup>	20		25		ns
t <sub>S2</sub>	I/O Input Set-Up Time to Synchronous Clock Input <sup>[7]</sup>	36		45		ns
t <sub>H</sub>	Input Hold Time from Synchronous Clock Input <sup>[7]</sup>	0		0		ns
t <sub>WH</sub>	Synchronous Clock Input HIGH Time	10		12.5		ns
t <sub>WL</sub>	Synchronous Clock Input LOW Time	10		12.5		ns
t <sub>RW</sub>	Asynchronous Clear Width <sup>[4, 7]</sup>	30		35		ns
t <sub>RR</sub>	Asynchronous Clear Recovery Time <sup>[4, 7]</sup>	30		35		ns
t <sub>RO</sub>	Asynchronous Clear to Registered Output Delay <sup>[7]</sup>		30		35	ns
t <sub>PW</sub>	Asynchronous Preset Width <sup>[4, 7]</sup>	30		35		ns
t <sub>PR</sub>	Asynchronous Preset Recovery Time <sup>[4, 7]</sup>	30		35		ns
t <sub>PO</sub>	Asynchronous Preset to Registered Output Delay <sup>[7]</sup>		30		35	ns
t <sub>CF</sub>	Synchronous Clock to Local Feedback Input <sup>[4, 15]</sup>		3		6	ns
t <sub>P</sub>	External Synchronous Clock Period (1/(f <sub>MAX3</sub> )) <sup>[4]</sup>	20		25		ns
f <sub>MAX1</sub>	External Feedback Maximum Frequency (1/(t <sub>CO1</sub> + t <sub>S1</sub> )) <sup>[4, 16]</sup>	27.7		22.2		MHz
f <sub>MAX2</sub>	Internal Local Feedback Maximum Frequency, lesser of (1/(t <sub>S1</sub> + t <sub>CF</sub> )) or (1/t <sub>CO1</sub> ) <sup>[4, 17]</sup>	43.4		32.2		MHz
f <sub>MAX3</sub>	Data Path Maximum Frequency, lesser of (1/(t <sub>WL</sub> + t <sub>WH</sub> )), (1/(t <sub>S1</sub> + t <sub>H</sub> )) or (1/t <sub>CO1</sub> ) <sup>[4, 18]</sup>	50		40		MHz
f <sub>MAX4</sub>	Maximum Register Toggle Frequency (1/(t <sub>WL</sub> + t <sub>WH</sub> )) <sup>[4, 19]</sup>	50		40		MHz
t <sub>OH</sub>	Output Data Stable Time from Synchronous Clock Input <sup>[4, 20]</sup>	3		3		ns



**Military External Asynchronous Switching Characteristics<sup>[6]</sup> Over Operating Range**

Parameter	Description	7C346-30		7C346-35		Unit
		Min.	Max.	Min.	Max.	
t <sub>ACO1</sub>	Asynchronous Clock Input to Output Delay <sup>[7]</sup>		30		35	ns
t <sub>ACO2</sub>	Asynchronous Clock Input to Local Feedback to Combinatorial Output <sup>[20]</sup>		46		55	ns
t <sub>AS1</sub>	Dedicated Input or Feedback Set-Up Time to Asynchronous Clock Input <sup>[7]</sup>	6		8		ns
t <sub>AS2</sub>	I/O Input Set-Up Time to Asynchronous Clock Input <sup>[7]</sup>	22		28		ns
t <sub>AH</sub>	Input Hold Time from Asynchronous Clock Input <sup>[7]</sup>	8		10		ns
t <sub>AWH</sub>	Asynchronous Clock Input HIGH Time <sup>[7]</sup>	14		16		ns
t <sub>AWL</sub>	Asynchronous Clock Input LOW Time <sup>[7, 21]</sup>	11		14		ns
t <sub>ACF</sub>	Asynchronous Clock to Local Feedback Input <sup>[4, 22]</sup>		18		22	ns
t <sub>AP</sub>	External Asynchronous Clock Period (1/(f <sub>MAXA4</sub> )) <sup>[4]</sup>	25		30		ns
f <sub>MAXA1</sub>	External Feedback Maximum Frequency in Asynchronous Mode (1/(t <sub>ACO1</sub> + t <sub>AS1</sub> )) <sup>[4, 23]</sup>	27.7		23.2		MHz
f <sub>MAXA2</sub>	Maximum Internal Asynchronous Frequency <sup>[4, 24]</sup>	40		33.3		MHz
f <sub>MAXA3</sub>	Data Path Maximum Frequency in Asynchronous Mode <sup>[4, 25]</sup>	33.3		28.5		MHz
f <sub>MAXA4</sub>	Maximum Asynchronous Register Toggle Frequency 1/(t <sub>AWH</sub> + t <sub>AWL</sub> ) <sup>[4, 26]</sup>	40		33.3		MHz
t <sub>AOH</sub>	Output Data Stable Time from Asynchronous Clock Input <sup>[4, 27]</sup>	15		15		ns



**Military Typical Internal Switching Characteristics** Over Operating Range

Parameter	Description	7C346-30		7C346-35		Unit
		Min.	Max.	Min.	Max.	
t <sub>IN</sub>	Dedicated Input Pad and Buffer Delay		7		9	ns
t <sub>IO</sub>	I/O Input Pad and Buffer Delay		6		9	ns
t <sub>EXP</sub>	Expander Array Delay		14		20	ns
t <sub>LAD</sub>	Logic Array Data Delay		14		16	ns
t <sub>LAC</sub>	Logic Array Control Delay		12		13	ns
t <sub>OD</sub>	Output Buffer and Pad Delay		5		6	ns
t <sub>ZX</sub>	Output Buffer Enable Delay <sup>[28]</sup>		11		13	ns
t <sub>XZ</sub>	Output Buffer Disable Delay		11		13	ns
t <sub>RSU</sub>	Register Set-Up Time Relative to Clock Signal at Register	8		10		ns
t <sub>RH</sub>	Register Hold Time Relative to Clock Signal at Register	8		10		ns
t <sub>LATCH</sub>	Flow Through Latch Delay		4		4	ns
t <sub>RD</sub>	Register Delay		2		2	ns
t <sub>COMB</sub>	Transparent Mode Delay <sup>[29]</sup>		4		4	ns
t <sub>CH</sub>	Clock HIGH Time	10		12.5		ns
t <sub>CL</sub>	Clock LOW Time	10		12.5		ns
t <sub>IC</sub>	Asynchronous Clock Logic Delay		16		18	ns
t <sub>ICS</sub>	Synchronous Clock Delay		2		3	ns
t <sub>FD</sub>	Feedback Delay		1		2	ns
t <sub>PRE</sub>	Asynchronous Register Preset Time		6		7	ns
t <sub>CLR</sub>	Asynchronous Register Clear Time		6		7	ns
t <sub>PCW</sub>	Asynchronous Preset and Clear Pulse Width	6		7		ns
t <sub>PCR</sub>	Asynchronous Preset and Clear Recovery Time	6		7		ns
t <sub>PIA</sub>	Programmable Interconnect Array Delay Time		16		20	ns

### Switching Waveforms

#### External Combinatorial

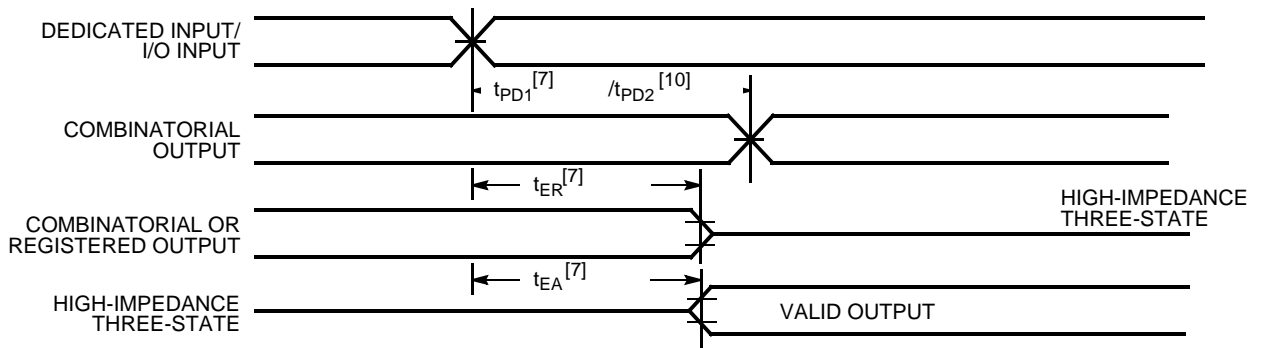

#### External Synchronous

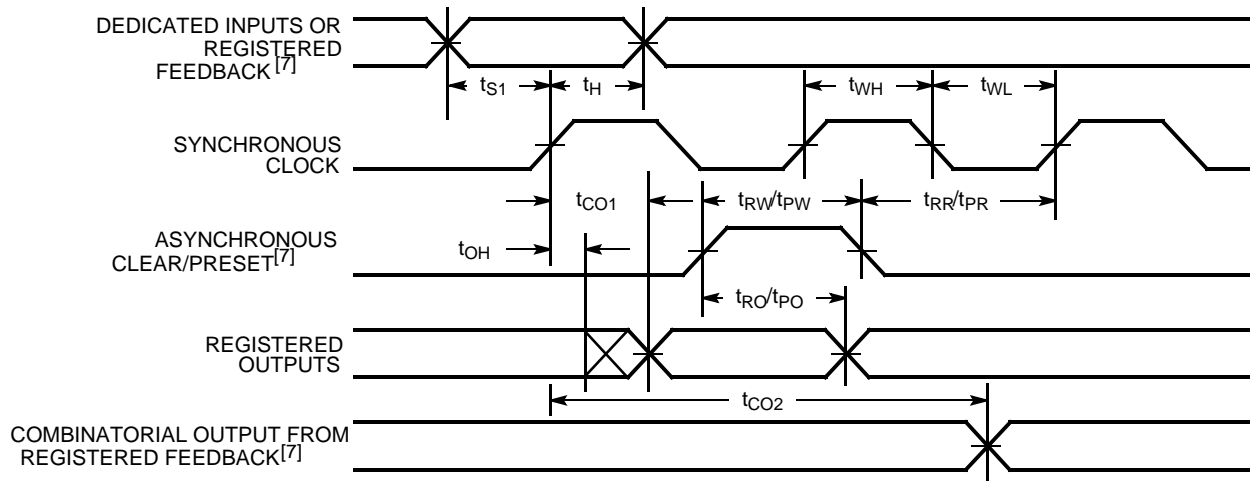

#### External Asynchronous

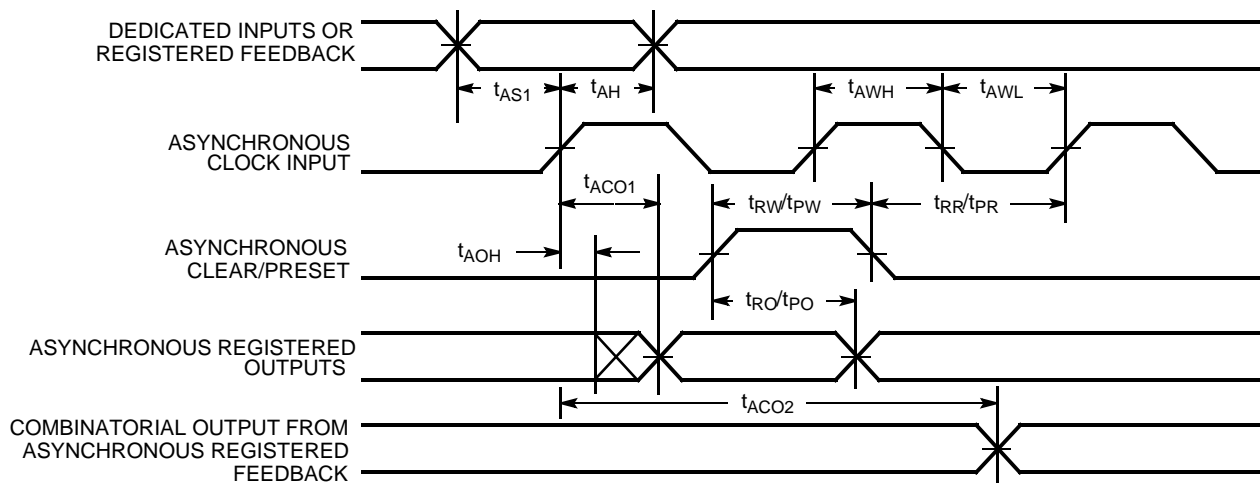

**Switching Waveforms (continued)**

**Internal Combinatorial**

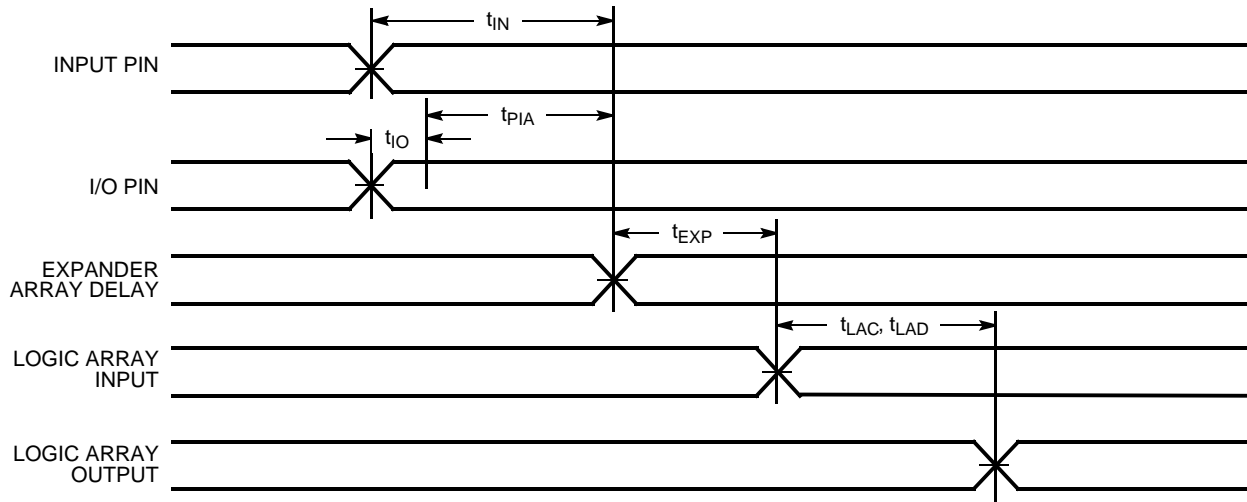

**Internal Asynchronous**

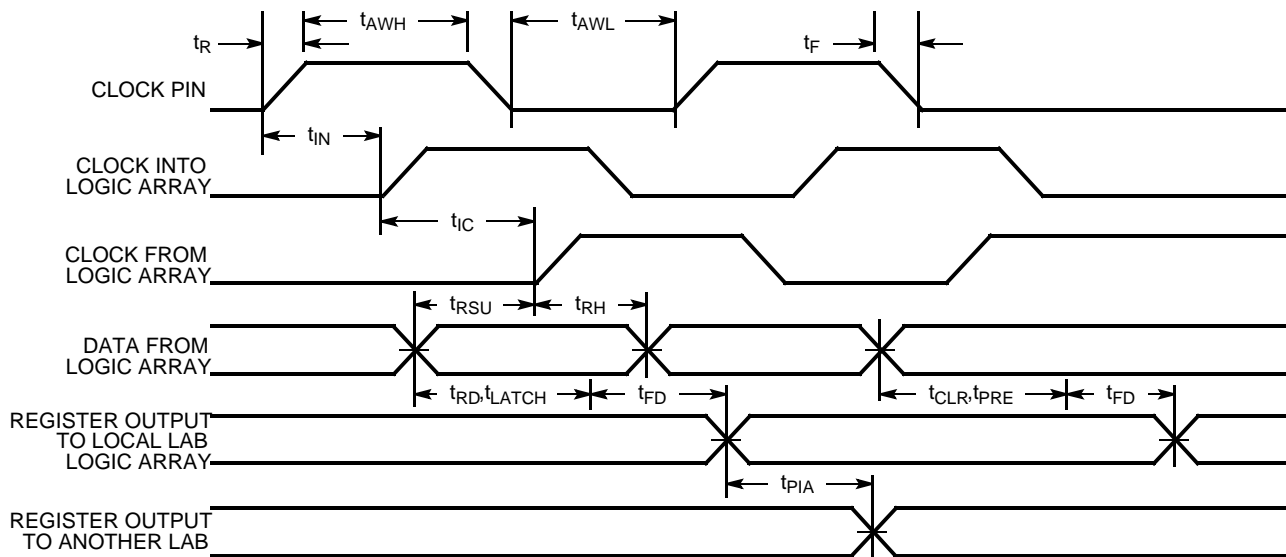

**Internal Synchronous**

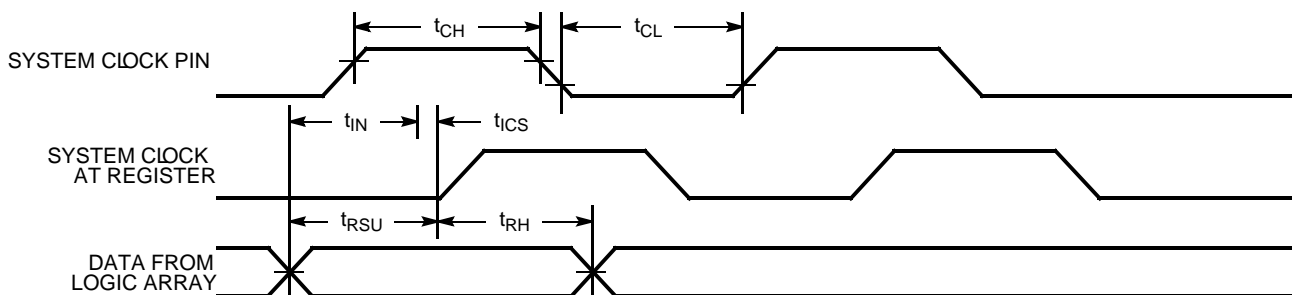

**Switching Waveforms** (continued)

**Internal Synchronous**

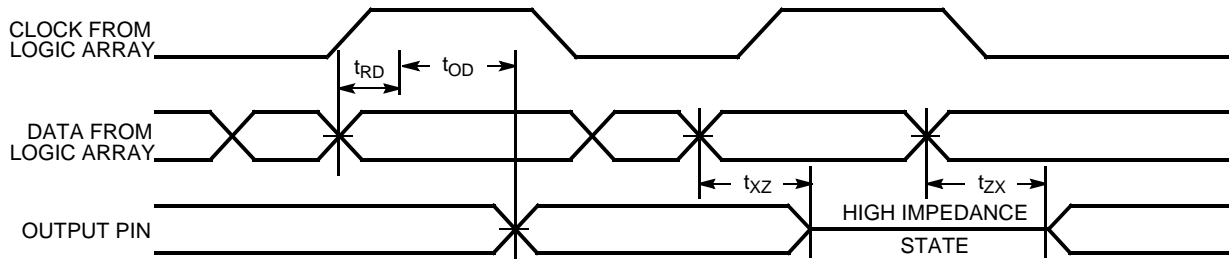





**MILITARY SPECIFICATIONS  
Group A Subgroup Testing**

**DC Characteristics**

Parameter	Subgroups
V <sub>OH</sub>	1, 2, 3
V <sub>OL</sub>	1, 2, 3
V <sub>IH</sub>	1, 2, 3
V <sub>IL</sub>	1, 2, 3
I <sub>Ix</sub>	1, 2, 3
I <sub>OZ</sub>	1, 2, 3
I <sub>CC1</sub>	1, 2, 3

**Switching Characteristics**

Parameter	Subgroups
t <sub>PD1</sub>	7, 8, 9, 10, 11
t <sub>PD2</sub>	7, 8, 9, 10, 11
t <sub>PD3</sub>	7, 8, 9, 10, 11
t <sub>CO1</sub>	7, 8, 9, 10, 11
t <sub>S1</sub>	7, 8, 9, 10, 11
t <sub>S2</sub>	7, 8, 9, 10, 11
t <sub>H</sub>	7, 8, 9, 10, 11
t <sub>WH</sub>	7, 8, 9, 10, 11
t <sub>WL</sub>	7, 8, 9, 10, 11
t <sub>RO</sub>	7, 8, 9, 10, 11
t <sub>PO</sub>	7, 8, 9, 10, 11
t <sub>ACO1</sub>	7, 8, 9, 10, 11
t <sub>ACO2</sub>	7, 8, 9, 10, 11
t <sub>AS1</sub>	7, 8, 9, 10, 11
t <sub>AH</sub>	7, 8, 9, 10, 11
t <sub>AWH</sub>	7, 8, 9, 10, 11
t <sub>AWL</sub>	7, 8, 9, 10, 11

**Ordering Information**

Speed (ns)	Ordering Code	Package Name	Package Type	Operating Range
25	CY7C346-25HC/HI	H84	84-pin Windowed Leaded Chip Carrier	Commercial/Industrial
	CY7C346-25JC/JI	J83	84-lead Plastic Leaded Chip Carrier	
	CY7C346-25NC/NI	N100	100-lead Plastic Quad Flatpack	
	CY7C346-25RC/RI	R100	100-pin Windowed Ceramic Pin Grid Array	
30	CY7C346-30HC/HI	H84	84-pin Windowed Leaded Chip Carrier	Commercial/Industrial
	CY7C346-30JC/JI	J83	84-lead Plastic Leaded Chip Carrier	
	CY7C346-30NC/NI	N100	100-lead Plastic Quad Flatpack	
	CY7C346-30HMB	H84	84-pin Windowed Leaded Chip Carrier	
	CY7C346-30RMB	R100	100-pin Windowed Ceramic Pin Grid Array	Military

**Ordering Information** (continued)

Speed (ns)	Ordering Code	Package Name	Package Type	Operating Range
35	CY7C346-35JC/JI	J83	84-lead Plastic Leaded Chip Carrier	Commercial/Industrial
	CY7C346-35NC/NI	N100	100-lead Plastic Quad Flatpack	
	CY7C346-35RC/RI	R100	100-pin Windowed Ceramic Pin Grid Array	
	CY7C346-35HMB	H84	84-pin Windowed Leaded Chip Carrier	Military
	CY7C346-35RMB	R100	100-pin Windowed Ceramic Pin Grid Array	

**Package Diagrams**

**84-Leaded Windowed Leaded Chip Carrier H84**

DIMENSIONS IN INCHES

MIN.  
MAX.

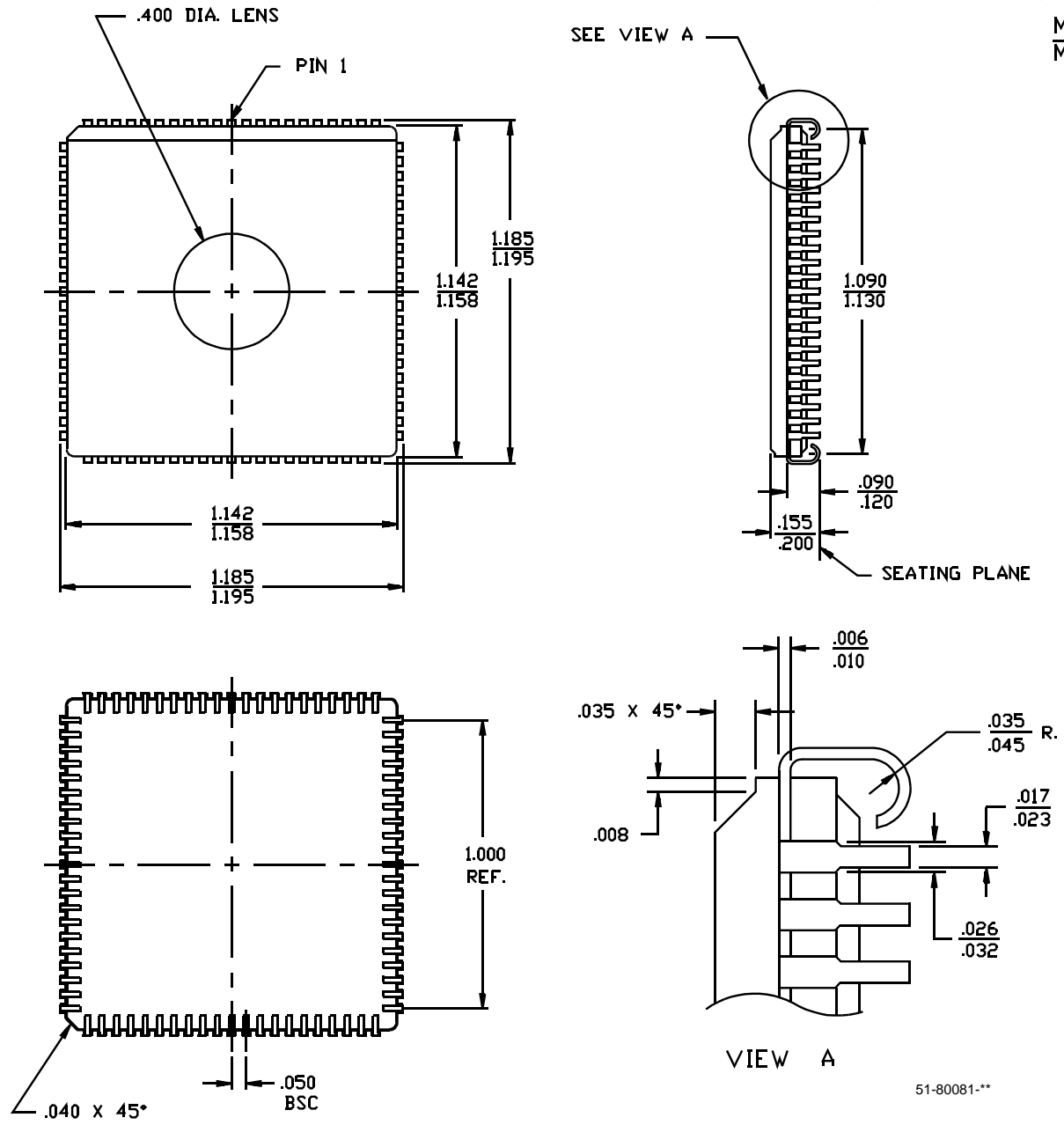

51-80081-\*\*

Package Diagrams (continued)

84-Lead Plastic Leaded Chip Carrier J83

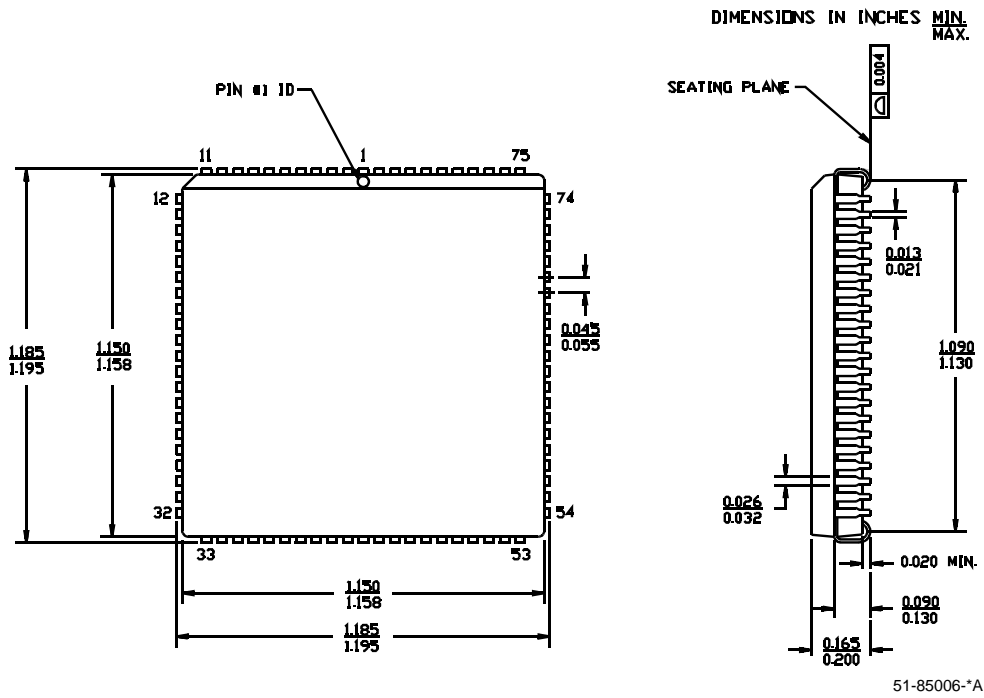

Package Diagrams (continued)

100-Lead Plastic Quad Flatpack N100

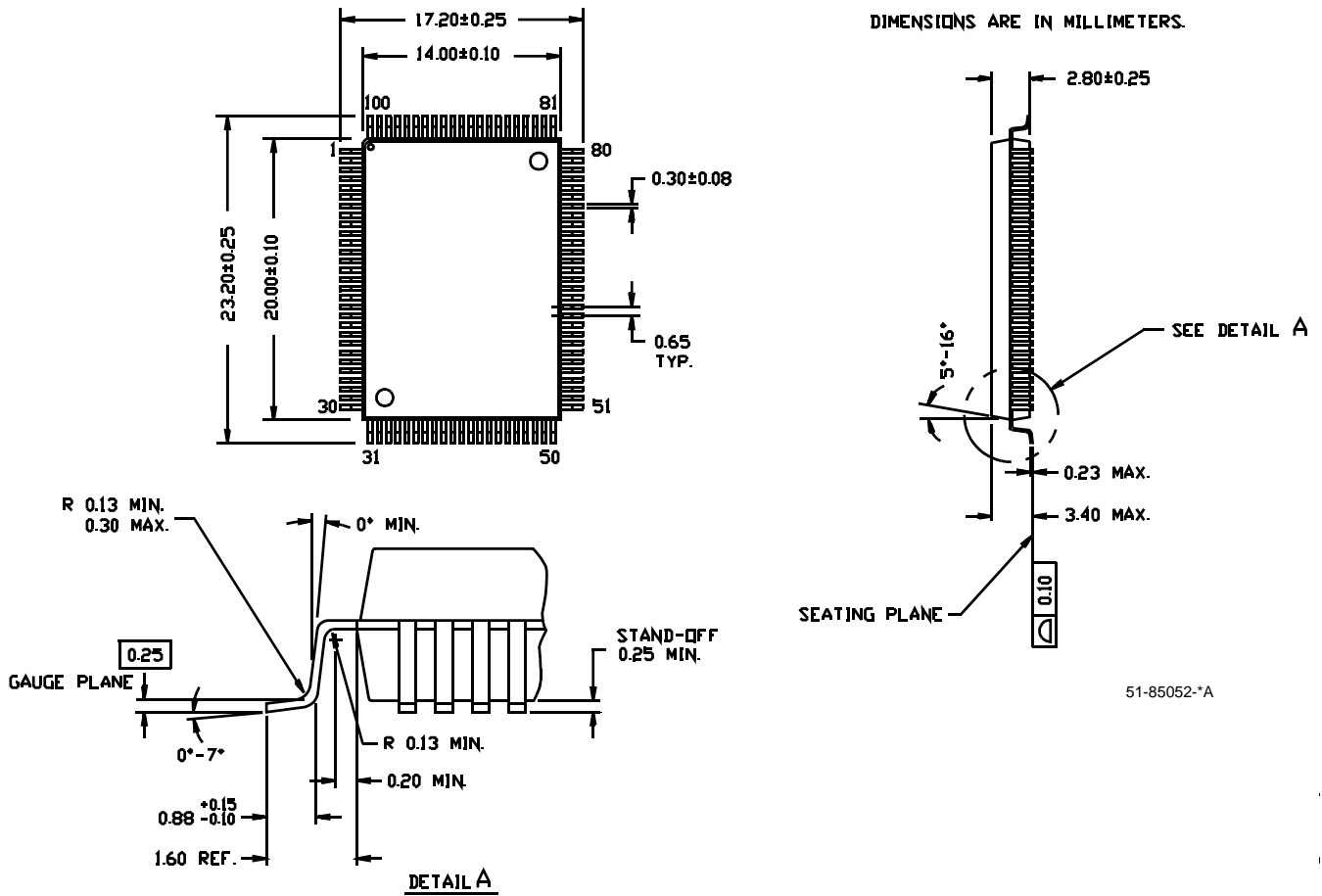

51-85052-\*A

**Package Diagrams** (continued)

**100-Pin Windowed Ceramic Pin Grid Array R100**

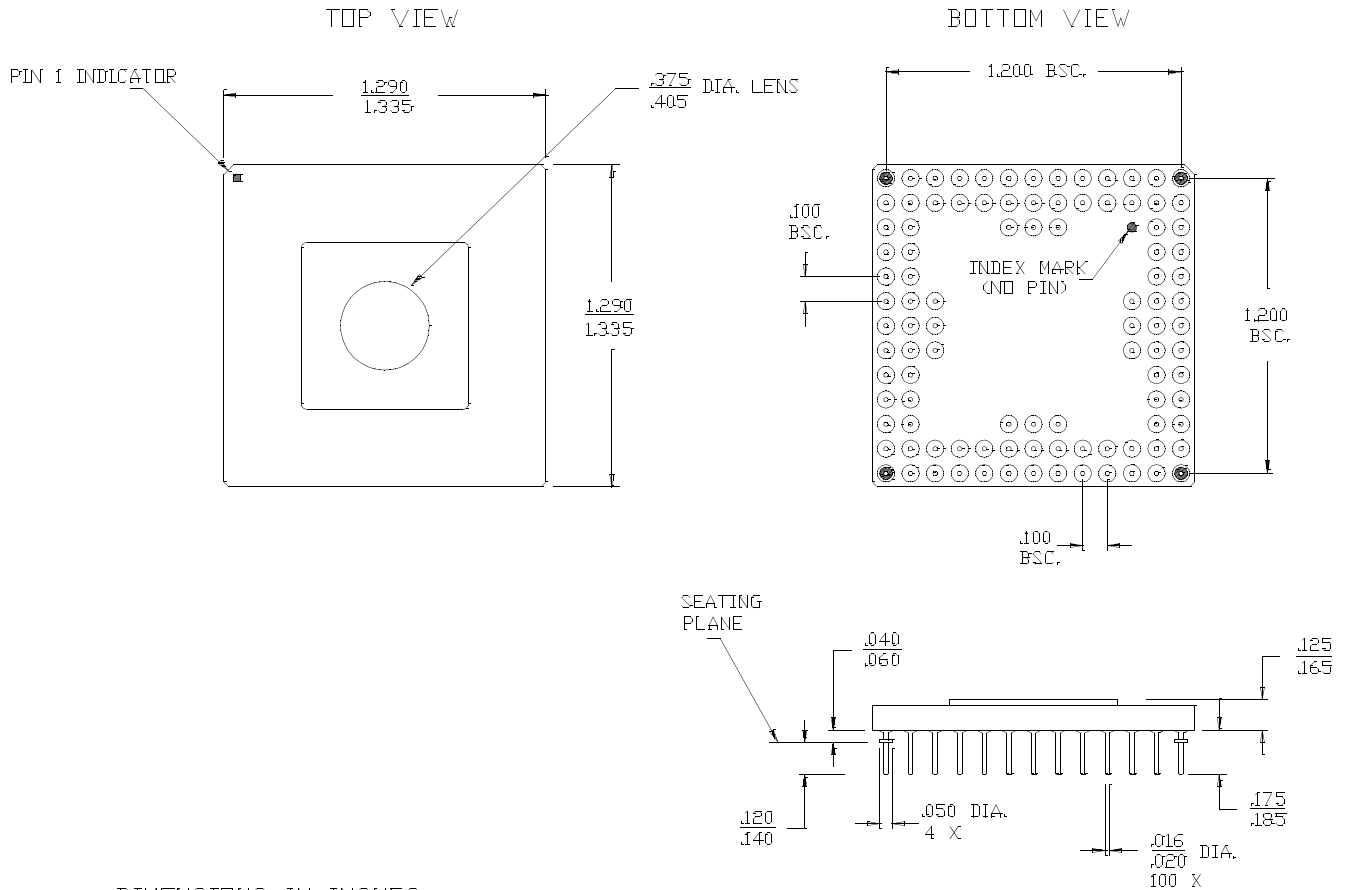

DIMENSIONS IN INCHES

MIN.  
MAX.

51-80010-°C

MAX and *Warp* are registered trademarks and Ultra37000, *Warp Professional* and *Warp Enterprise* are trademarks of Cypress Semiconductor Corporation. All product and company names mentioned in this document are the trademarks of their respective holders.



**USE ULTRA37000™ FOR  
ALL NEW DESIGNS**

**CY7C346**

**Document History Page**

<b>Document Title: CY7C346 128-Macrocell MAX® EPLD</b> <b>Document Number: 38-03005</b>				
<b>REV.</b>	<b>ECN NO.</b>	<b>Issue Date</b>	<b>Orig. of Change</b>	<b>Description of Change</b>
**	106270	04/23/01	SZV	Change from Spec number 38-00244 to 38-03005
*A	113614	04/11/02	OOR	PGA package diagram dimensions updated
*B	213375	See ECN	FSG	Added note to title page: "Use Ultra37000 For All New Designs"