

S6B33B0A

144 RGB Segment & 177 Common Driver For 65,536 Color STN LCD

August. 12. 2002
Ver. 1.1

Contents in this document are subject to change without notice. No part of this document may be reproduced or transmitted in any form or by any means, electronic or mechanical, for any purpose, without the express written permission of LCD Driver IC Team.

Precautions for Light

Light has characteristics to move electrons in the integrated circuitry of semiconductors, therefore may change the characteristics of semiconductor devices when irradiated with light. Consequently, the users of the packages which may expose chips to external light such as COB, COG, TCP and COF must consider effective methods to block out light from reaching the IC on all parts of the surface area, the top, bottom and the sides of the chip. Follow the precautions below when using the products.

1. Consider and verify the protection of penetrating light to the IC at substrate (board or glass) or product design stage.
2. Always test and inspect products under the environment with no penetration of light.

S6B33B0A Specification Revision History		
Version	Content	Date
0.0	Original Neglect the more past version than version 0.0	Mar. 2002
0.1	Add the schottky barrier diode connection between VEE and VSS at the system application diagram	May. 2002
0.2	Append the schottky barrier diode specification Append the addressing condition for the 256 color and 4.096 color mode	June. 2002
0.3	Append the power on/off sequences.	June. 2002
1.0	Definition of TBD items	July. 2002
1.1	Modify REG_OUT range: 1.8 to 1.9V -> 1.8 to 2.2V Add the DC spec for VIN2, DC2IN, VIN45.	Aug. 2002

CONTENTS

INTRODUCTION	1
FEATURES	1
BLOCK DIAGRAM	2
PAD CONFIGURATION	3
PIN CONFIGURATION.....	5
PAD CENTER COORDINATES	6
PIN DESCRIPTION	11
PIN DESCRIPTION	12
FUNCTIONAL DESCRIPTION	15
MPU INTERFACE	15
DISPLAY DATA RAM	19
INSTRUCTION DESCRIPTION	28
INSTRUCTION PARAMETER.....	56
POWER ON/OFF SEQUENCE	59
SPECIFICATIONS	61
ABSOLUTE MAXIMUM RATINGS	61
OPERATING VOLTAGE	61
DC CHARACTERISTICS (1)	62
DC CHARACTERISTICS (2)	63
DC CHARACTERISTICS (3)	64
DC CHARACTERISTICS (4)	65
DC CHARACTERISTICS (5)	66
AC CHARACTERISTICS.....	67
SYSTEM APPLICATION DIAGRAM.....	71

INTRODUCTION

S6B33B0A is a mid-display-size-compatible driver for liquid crystal dot matrix gray-scale graphic systems. With on-chip CR oscillator circuit, the display-timing signal is generated without being sent from MPU. Also, it is capable of using 8bit/16bit data bus alternatively and operating with 68/80-series MPU in asynchronous. Due to the LCD driving signal (144 RGB X 177 output) corresponding to the display data and the internal bit-map display RAM of 144 ×176 ×16-bit, S6B33B0A is capable of operating max. 144 RGB x 177 dot LCD panels in low-power consumption. Being the segment RGB 3-output, one pixel is 16-bit data and S6B33B0A can max display 65,536 color.

FEATURES

Driver Output

- 144 RGB x 177

Gray Scale Function

- 65,536 color display of R: 32 gray scale, G: 64 gray scale, B: 32 gray scale
- 4,096 color display of R: 16 gray scale, G: 16 gray scale, B: 16 gray scale
- 256 color display of R: 8 gray scale, G: 8 gray scale, B: 4 gray scale

On-chip Display Data RAM

- Capacity: 144 x 16 x 176 = 405.504k bits
- Burst RAM write function

Display Mode

- Normal display mode: Entire duty displaying
- Partial display mode: Partial duty displaying
- Standby mode: Internal display clocks off
- Area scroll mode: Particular area scrolling

Microprocessor Interface

- 8-bit/16 bit parallel bi-directional interface with 6800-series or 8080-series
- 3/4 Pin SPI (only write operation)

On-chip Low Power Analog Circuit

- On-chip CR oscillator (Internal cap. & external resistor), external clock available
- Voltage converter / Voltage regulator / Voltage follower
- On-chip electronic contrast control (256 steps)

Operating Voltage Range

- VDD : 1.8 to 3.3 [V] (without Internal Regulator), 2.4 to 3.3 [V] (With internal Regulator)
- VIN1: 2.4 to 3.6 [V]
- Display operating voltage(V1): 2.0 to 4.0 V
- LCD Operating Voltage Range : Max. 20 V

Low Power Consumption

- 650 μ A Typ. (Refer to DC CHARACTERISTICS (2))

Package Type

- COG (Output Pad Pitch Min. 40 μ m)



BLOCK DIAGRAM

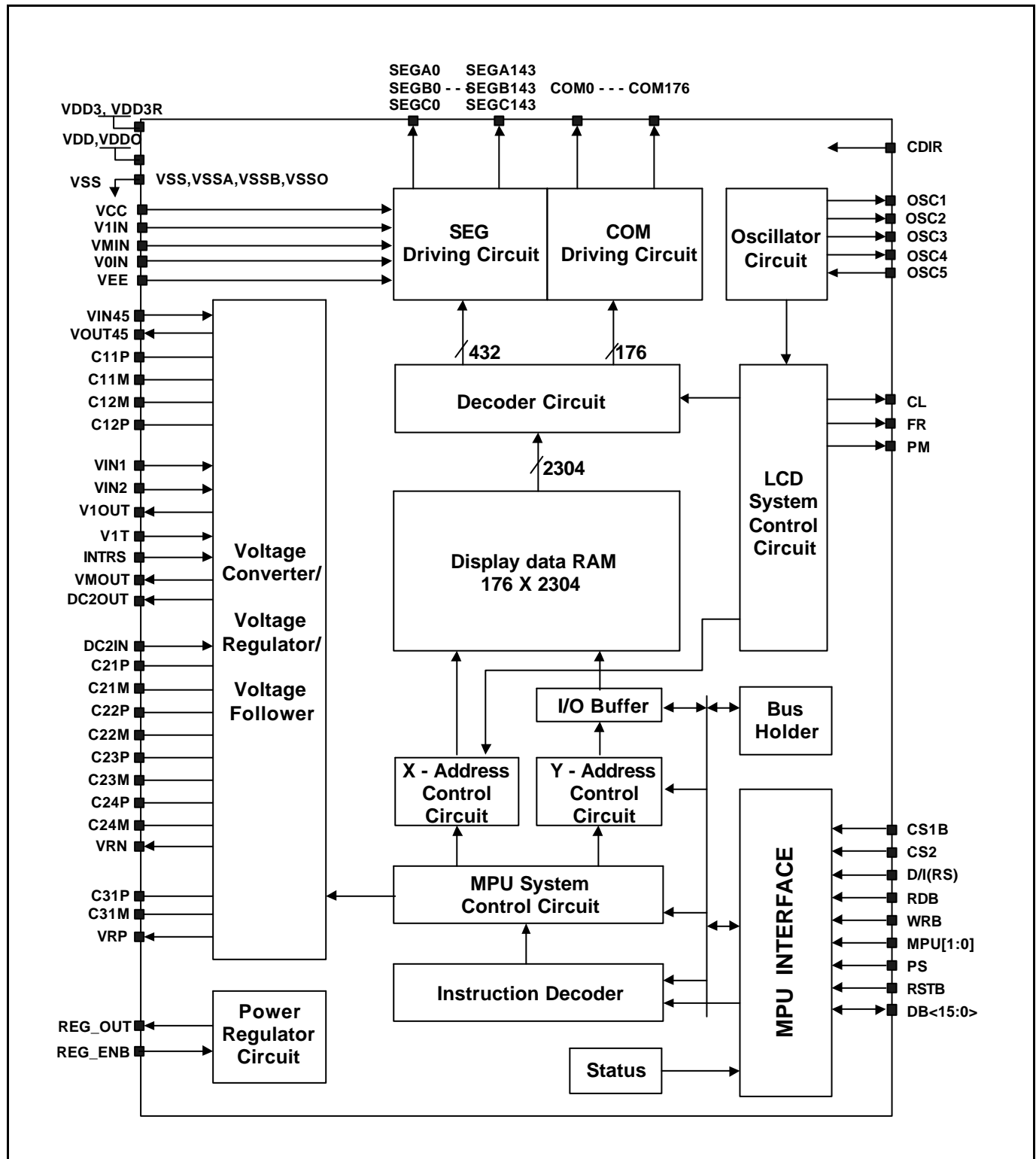

Figure 1. Block Diagram

PAD CONFIGURATION

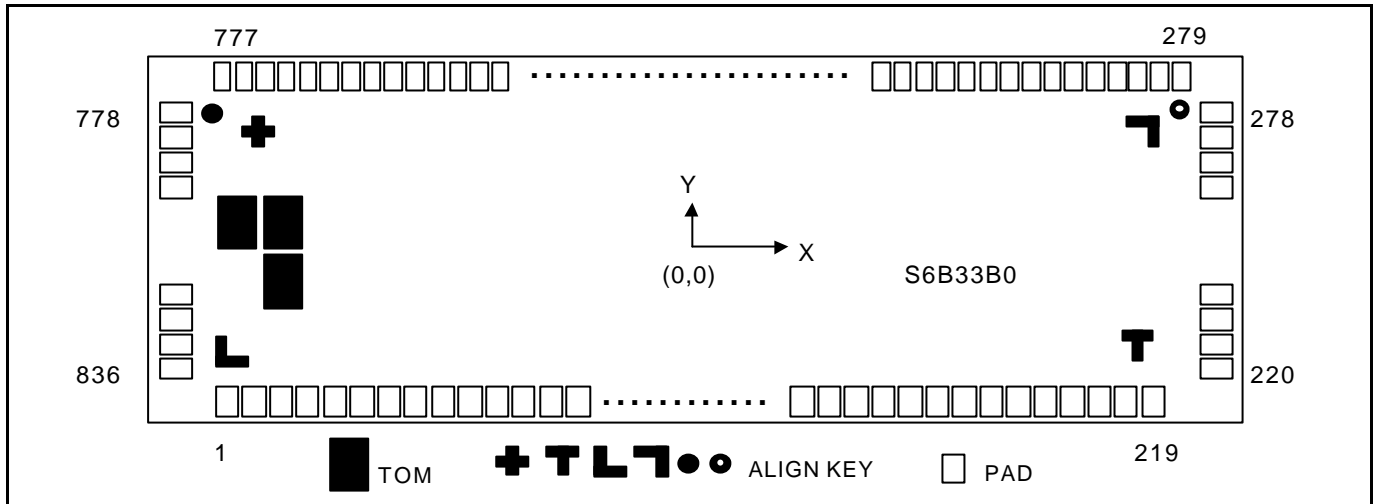

Figure 2. S6B33B0A Chip Pad Configuration

Table 1. S6B33B0A Pad Dimensions

Item	Pad No.	Size		Unit
		X	Y	
Chip size (with S/L 120µm)		20644	2870	µm
Pad pitch	1 to 219	90		
	220 to 278, 279 to 777, 778 to 836	40		
Bumped pad size	1 to 219	70	70	
	220 to 278, , 778 to 836	150	25	
	279 to 777	25	150	
Bumped pad height	All pad	17		

COG Align Key Coordinate

ILB Align Key Coordinate

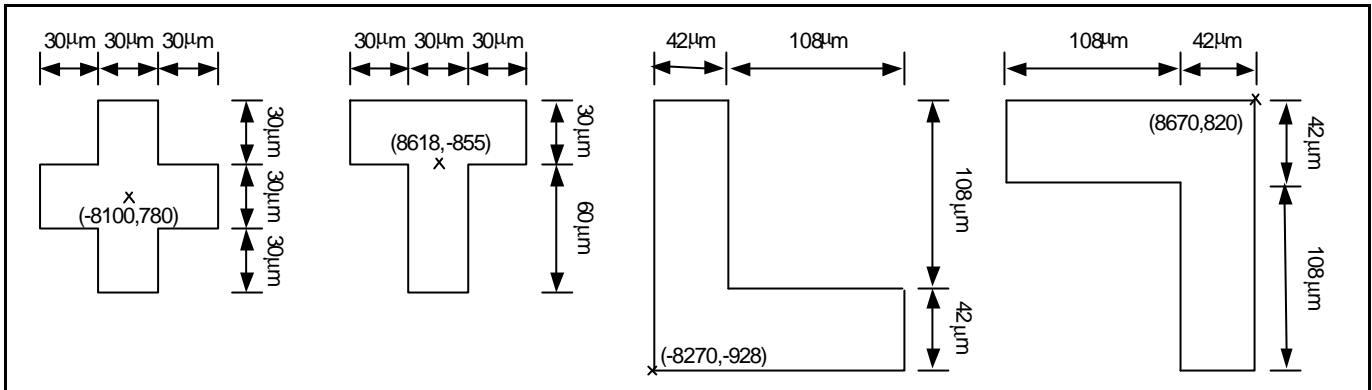
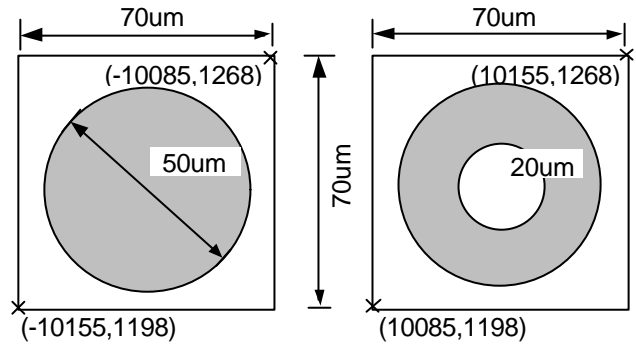
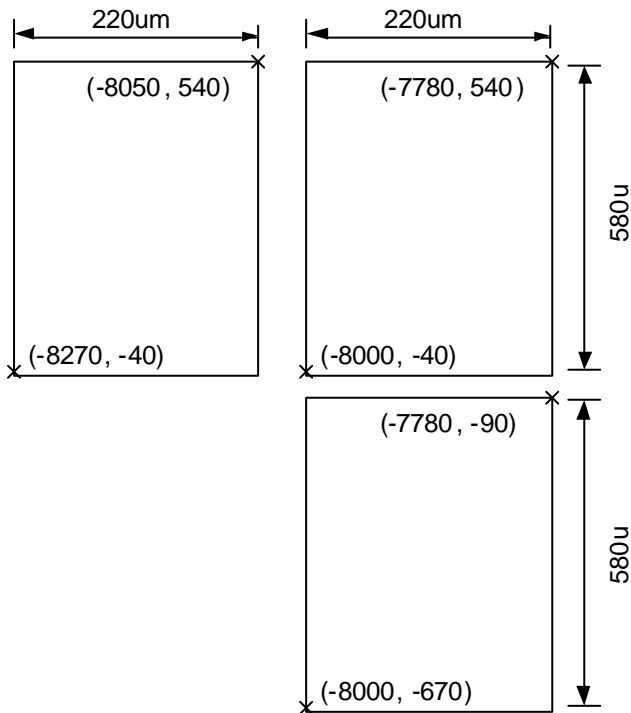

Figure 3. COG Align Key Coordinate

Figure 4. ILB Align Key Coordinate

TOM(TEG On Main chip) Coordinate

COF Align Key Coordinate



PIN CONFIGURATION

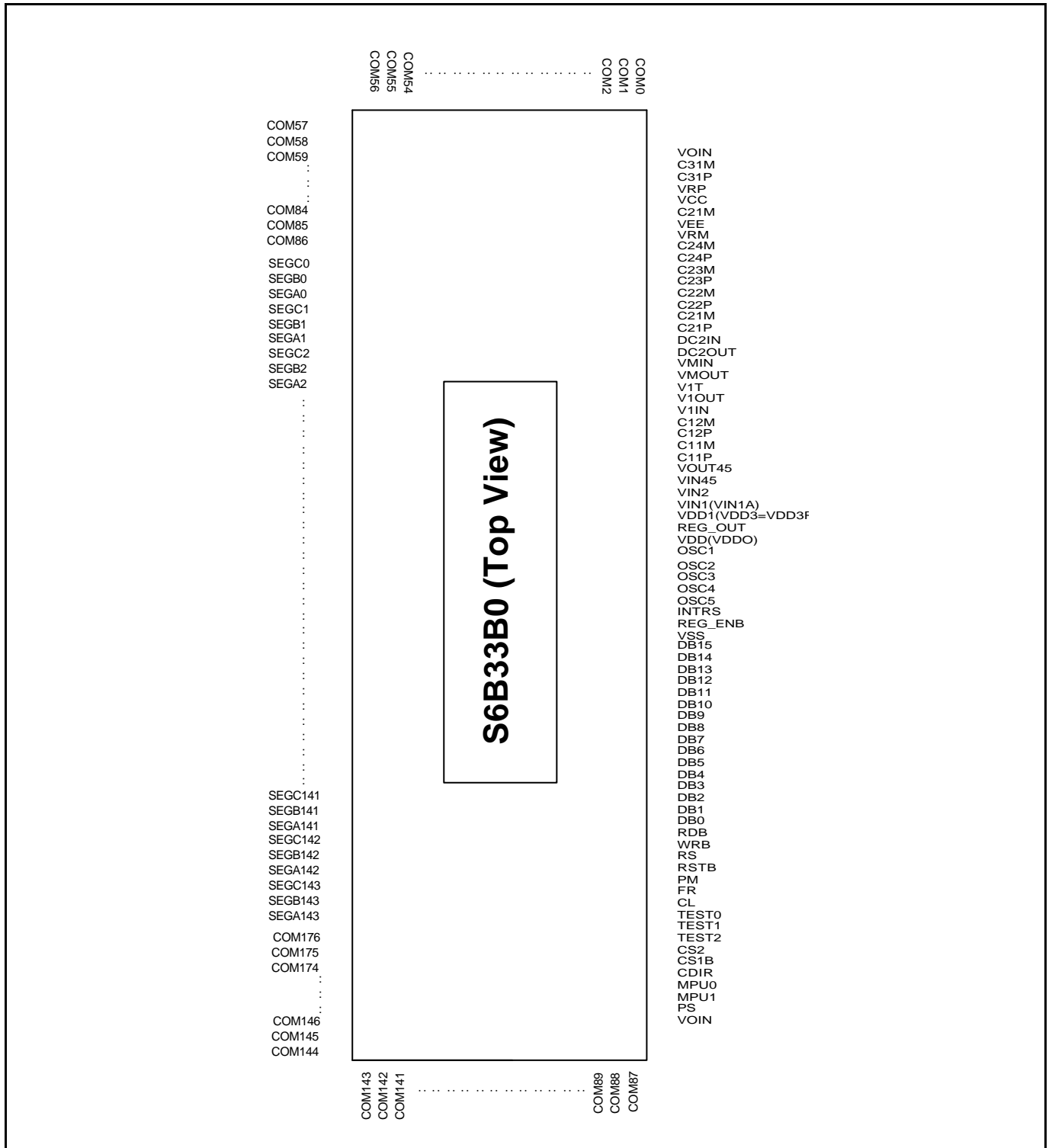

Figure 5. S6B33B0A Chip Pin Configuration

PAD CENTER COORDINATES

Table 2. Pad Center Coordinates

[Unit: μm]

No	X	Y	NAME	No	X	Y	NAME	No	X	Y	NAME
1	-9808	-1320	DUMMY<0>	51	-5308	-1320	VSS	101	-808	-1320	VDD3
2	-9718	-1320	DUMMY<1>	52	-5218	-1320	VSS	102	-718	-1320	VDD3
3	-9628	-1320	VOIN	53	-5128	-1320	VSS	103	-628	-1320	VDD3
4	-9538	-1320	VOIN	54	-5038	-1320	VSS	104	-538	-1320	VDD3
5	-9448	-1320	VOIN	55	-4948	-1320	VSSA	105	-448	-1320	VDD3
6	-9358	-1320	VOIN	56	-4858	-1320	VSSA	106	-358	-1320	VIN1
7	-9268	-1320	VSS	57	-4768	-1320	VSSA	107	-268	-1320	VIN1
8	-9178	-1320	PS	58	-4678	-1320	VSSA	108	-178	-1320	VIN1
9	-9088	-1320	VDD3	59	-4588	-1320	VSSO	109	-88	-1320	VIN1
10	-8998	-1320	MPU1	60	-4498	-1320	VSSO	110	2	-1320	VIN1
11	-8908	-1320	VSS	61	-4408	-1320	VSSB	111	92	-1320	VIN1
12	-8818	-1320	MPU0	62	-4318	-1320	VSSB	112	182	-1320	VIN1
13	-8728	-1320	VDD3	63	-4228	-1320	VSSB	113	272	-1320	VIN1
14	-8638	-1320	CDIR	64	-4138	-1320	VSSB	114	362	-1320	VIN1
15	-8548	-1320	VSS	65	-4048	-1320	VSSB	115	452	-1320	VIN1
16	-8458	-1320	CS1B	66	-3958	-1320	VSSB	116	542	-1320	VIN1
17	-8368	-1320	CS2	67	-3868	-1320	VSSB	117	632	-1320	VIN1
18	-8278	-1320	TEST2	68	-3778	-1320	VSSB	118	722	-1320	VIN1A
19	-8188	-1320	TEST1	69	-3688	-1320	VSSB	119	812	-1320	VIN1A
20	-8098	-1320	TEST0	70	-3598	-1320	VSSB	120	902	-1320	VIN1A
21	-8008	-1320	VDD3	71	-3508	-1320	REG_ENB	121	992	-1320	VIN1A
22	-7918	-1320	CL	72	-3418	-1320	VDD3	122	1082	-1320	VIN2
23	-7828	-1320	FR	73	-3328	-1320	INTRS	123	1172	-1320	VIN2
24	-7738	-1320	PM	74	-3238	-1320	OSC5	124	1262	-1320	VIN2
25	-7648	-1320	RSTB	75	-3148	-1320	VSS	125	1352	-1320	VIN2
26	-7558	-1320	RS	76	-3058	-1320	OSC4	126	1442	-1320	VIN2
27	-7468	-1320	VSS	77	-2968	-1320	OSC3	127	1532	-1320	VIN45
28	-7378	-1320	WRB	78	-2878	-1320	OSC2	128	1622	-1320	VIN45
29	-7288	-1320	RDB	79	-2788	-1320	OSC1	129	1712	-1320	VIN45
30	-7198	-1320	VDD3	80	-2698	-1320	VDDO	130	1802	-1320	VOUT45
31	-7108	-1320	DB0	81	-2608	-1320	VDDO	131	1892	-1320	VOUT45
32	-7018	-1320	DB1	82	-2518	-1320	VDD	132	1982	-1320	VOUT45
33	-6928	-1320	DB2	83	-2428	-1320	VDD	133	2072	-1320	C11P
34	-6838	-1320	DB3	84	-2338	-1320	VDD	134	2162	-1320	C11P
35	-6748	-1320	DB4	85	-2248	-1320	VDD	135	2252	-1320	C11P
36	-6658	-1320	DB5	86	-2158	-1320	VDD	136	2342	-1320	C11M
37	-6568	-1320	DB6	87	-2068	-1320	VDD	137	2432	-1320	C11M
38	-6478	-1320	DB7	88	-1978	-1320	REG_OUT	138	2522	-1320	C11M
39	-6388	-1320	DB8	89	-1888	-1320	REG_OUT	139	2612	-1320	C12P
40	-6298	-1320	DB9	90	-1798	-1320	REG_OUT	140	2702	-1320	C12P
41	-6208	-1320	DB10	91	-1708	-1320	REG_OUT	141	2792	-1320	C12P
42	-6118	-1320	DB11	92	-1618	-1320	REG_OUT	142	2882	-1320	C12M
43	-6028	-1320	DB12	93	-1528	-1320	REG_OUT	143	2972	-1320	C12M
44	-5938	-1320	DB13	94	-1438	-1320	VDD3R	144	3062	-1320	C12M
45	-5848	-1320	DB14	95	-1348	-1320	VDD3R	145	3152	-1320	V1IN
46	-5758	-1320	DB15	96	-1258	-1320	VDD3R	146	3242	-1320	V1IN
47	-5668	-1320	VSS	97	-1168	-1320	VDD3R	147	3332	-1320	V1IN
48	-5578	-1320	VSS	98	-1078	-1320	VDD3R	148	3422	-1320	V1OUT
49	-5488	-1320	VSS	99	-988	-1320	VDD3R	149	3512	-1320	V1OUT
50	-5398	-1320	VSS	100	-898	-1320	VDD3	150	3602	-1320	V1OUT

Table 2. Pad Center Coordinates (Continued)

[Unit: μm]

No	X	Y	NAME	No	X	Y	NAME	No	X	Y	NAME
151	3692	-1320	V1T	201	8192	-1320	VCC	251	10120	0	COM<30>
152	3782	-1320	V1T	202	8282	-1320	VCC	252	10120	40	COM<31>
153	3872	-1320	VMOUT	203	8372	-1320	VCC	253	10120	80	COM<32>
154	3962	-1320	VMOUT	204	8462	-1320	VRP	254	10120	120	COM<33>
155	4052	-1320	VMOUT	205	8552	-1320	VRP	255	10120	160	COM<34>
156	4142	-1320	VMOUT	206	8642	-1320	VRP	256	10120	200	COM<35>
157	4232	-1320	VMIN	207	8732	-1320	C31P	257	10120	240	COM<36>
158	4322	-1320	VMIN	208	8822	-1320	C31P	258	10120	280	COM<37>
159	4412	-1320	VMIN	209	8912	-1320	C31P	259	10120	320	COM<38>
160	4502	-1320	VMIN	210	9002	-1320	C31M	260	10120	360	COM<39>
161	4592	-1320	DC2OUT	211	9092	-1320	C31M	261	10120	400	COM<40>
162	4682	-1320	DC2OUT	212	9182	-1320	C31M	262	10120	440	COM<41>
163	4772	-1320	DC2OUT	213	9272	-1320	DUMMY<4>	263	10120	480	COM<42>
164	4862	-1320	DC2IN	214	9362	-1320	VSS	264	10120	520	COM<43>
165	4952	-1320	DC2IN	215	9452	-1320	V0IN	265	10120	560	COM<44>
166	5042	-1320	DC2IN	216	9542	-1320	V0IN	266	10120	600	COM<45>
167	5132	-1320	C21P	217	9632	-1320	V0IN	267	10120	640	COM<46>
168	5222	-1320	C21P	218	9722	-1320	DUMMY<5>	268	10120	680	COM<47>
169	5312	-1320	C21P	219	9812	-1320	DUMMY<6>	269	10120	720	COM<48>
170	5402	-1320	C21M	220	10120	-1240	DUMMY<7>	270	10120	760	COM<49>
171	5492	-1320	C21M	221	10120	-1200	COM<0>	271	10120	800	COM<50>
172	5582	-1320	C21M	222	10120	-1160	COM<1>	272	10120	840	COM<51>
173	5672	-1320	C22P	223	10120	-1120	COM<2>	273	10120	880	COM<52>
174	5762	-1320	C22P	224	10120	-1080	COM<3>	274	10120	920	COM<53>
175	5852	-1320	C22P	225	10120	-1040	COM<4>	275	10120	960	COM<54>
176	5942	-1320	C22M	226	10120	-1000	COM<5>	276	10120	1000	COM<55>
177	6032	-1320	C22M	227	10120	-960	COM<6>	277	10120	1040	COM<56>
178	6122	-1320	C22M	228	10120	-920	COM<7>	278	10120	1080	DUMMY<8>
179	6212	-1320	C23P	229	10120	-880	COM<8>	279	9960	1233	DUMMY<9>
180	6302	-1320	C23P	230	10120	-840	COM<9>	280	9920	1233	COM<57>
181	6392	-1320	C23P	231	10120	-800	COM<10>	281	9880	1233	COM<58>
182	6482	-1320	C23M	232	10120	-760	COM<11>	282	9840	1233	COM<59>
183	6572	-1320	C23M	233	10120	-720	COM<12>	283	9800	1233	COM<60>
184	6662	-1320	C23M	234	10120	-680	COM<13>	284	9760	1233	COM<61>
185	6752	-1320	C24P	235	10120	-640	COM<14>	285	9720	1233	COM<62>
186	6842	-1320	C24P	236	10120	-600	COM<15>	286	9680	1233	COM<63>
187	6932	-1320	C24P	237	10120	-560	COM<16>	287	9640	1233	COM<64>
188	7022	-1320	C24M	238	10120	-520	COM<17>	288	9600	1233	COM<65>
189	7112	-1320	C24M	239	10120	-480	COM<18>	289	9560	1233	COM<66>
190	7202	-1320	C24M	240	10120	-440	COM<19>	290	9520	1233	COM<67>
191	7292	-1320	VRN	241	10120	-400	COM<20>	291	9480	1233	COM<68>
192	7382	-1320	VRN	242	10120	-360	COM<21>	292	9440	1233	COM<69>
193	7472	-1320	VRN	243	10120	-320	COM<22>	293	9400	1233	COM<70>
194	7562	-1320	VEE	244	10120	-280	COM<23>	294	9360	1233	COM<71>
195	7652	-1320	VEE	245	10120	-240	COM<24>	295	9320	1233	COM<72>
196	7742	-1320	VEE	246	10120	-200	COM<25>	296	9280	1233	COM<73>
197	7832	-1320	VEES	247	10120	-160	COM<26>	297	9240	1233	COM<74>
198	7922	-1320	VEES	248	10120	-120	COM<27>	298	9200	1233	COM<75>
199	8012	-1320	DUMMY<2>	249	10120	-80	COM<28>	299	9160	1233	COM<76>
200	8102	-1320	DUMMY<3>	250	10120	-40	COM<29>	300	9120	1233	COM<77>

Table 2. Pad Center Coordinates (Continued)

[Unit: μm]

No	X	Y	NAME	No	X	Y	NAME	No	X	Y	NAME
301	9080	1233	COM<78>	351	7080	1233	SEGB<13>	401	5080	1233	SEGC<30>
302	9040	1233	COM<79>	352	7040	1233	SEGA<13>	402	5040	1233	SEGB<30>
303	9000	1233	COM<80>	353	7000	1233	SEGC<14>	403	5000	1233	SEGA<30>
304	8960	1233	COM<81>	354	6960	1233	SEGB<14>	404	4960	1233	SEGC<31>
305	8920	1233	COM<82>	355	6920	1233	SEGA<14>	405	4920	1233	SEGB<31>
306	8880	1233	COM<83>	356	6880	1233	SEGC<15>	406	4880	1233	SEGA<31>
307	8840	1233	COM<84>	357	6840	1233	SEGB<15>	407	4840	1233	SEGC<32>
308	8800	1233	COM<85>	358	6800	1233	SEGA<15>	408	4800	1233	SEGB<32>
309	8760	1233	COM<86>	359	6760	1233	SEGC<16>	409	4760	1233	SEGA<32>
310	8720	1233	DUMMY<10>	360	6720	1233	SEGB<16>	410	4720	1233	SEGC<33>
311	8680	1233	SEGC<0>	361	6680	1233	SEGA<16>	411	4680	1233	SEGB<33>
312	8640	1233	SEGB<0>	362	6640	1233	SEGC<17>	412	4640	1233	SEGA<33>
313	8600	1233	SEGA<0>	363	6600	1233	SEGB<17>	413	4600	1233	SEGC<34>
314	8560	1233	SEGC<1>	364	6560	1233	SEGA<17>	414	4560	1233	SEGB<34>
315	8520	1233	SEGB<1>	365	6520	1233	SEGC<18>	415	4520	1233	SEGA<34>
316	8480	1233	SEGA<1>	366	6480	1233	SEGB<18>	416	4480	1233	SEGC<35>
317	8440	1233	SEGC<2>	367	6440	1233	SEGA<18>	417	4440	1233	SEGB<35>
318	8400	1233	SEGB<2>	368	6400	1233	SEGC<19>	418	4400	1233	SEGA<35>
319	8360	1233	SEGA<2>	369	6360	1233	SEGB<19>	419	4360	1233	SEGC<36>
320	8320	1233	SEGC<3>	370	6320	1233	SEGA<19>	420	4320	1233	SEGB<36>
321	8280	1233	SEGB<3>	371	6280	1233	SEGC<20>	421	4280	1233	SEGA<36>
322	8240	1233	SEGA<3>	372	6240	1233	SEGB<20>	422	4240	1233	SEGC<37>
323	8200	1233	SEGC<4>	373	6200	1233	SEGA<20>	423	4200	1233	SEGB<37>
324	8160	1233	SEGB<4>	374	6160	1233	SEGC<21>	424	4160	1233	SEGA<37>
325	8120	1233	SEGA<4>	375	6120	1233	SEGB<21>	425	4120	1233	SEGC<38>
326	8080	1233	SEGC<5>	376	6080	1233	SEGA<21>	426	4080	1233	SEGB<38>
327	8040	1233	SEGB<5>	377	6040	1233	SEGC<22>	427	4040	1233	SEGA<38>
328	8000	1233	SEGA<5>	378	6000	1233	SEGB<22>	428	4000	1233	SEGC<39>
329	7960	1233	SEGC<6>	379	5960	1233	SEGA<22>	429	3960	1233	SEGB<39>
330	7920	1233	SEGB<6>	380	5920	1233	SEGC<23>	430	3920	1233	SEGA<39>
331	7880	1233	SEGA<6>	381	5880	1233	SEGB<23>	431	3880	1233	SEGC<40>
332	7840	1233	SEGC<7>	382	5840	1233	SEGA<23>	432	3840	1233	SEGB<40>
333	7800	1233	SEGB<7>	383	5800	1233	SEGC<24>	433	3800	1233	SEGA<40>
334	7760	1233	SEGA<7>	384	5760	1233	SEGB<24>	434	3760	1233	SEGC<41>
335	7720	1233	SEGC<8>	385	5720	1233	SEGA<24>	435	3720	1233	SEGB<41>
336	7680	1233	SEGB<8>	386	5680	1233	SEGC<25>	436	3680	1233	SEGA<41>
337	7640	1233	SEGA<8>	387	5640	1233	SEGB<25>	437	3640	1233	SEGC<42>
338	7600	1233	SEGC<9>	388	5600	1233	SEGA<25>	438	3600	1233	SEGB<42>
339	7560	1233	SEGB<9>	389	5560	1233	SEGC<26>	439	3560	1233	SEGA<42>
340	7520	1233	SEGA<9>	390	5520	1233	SEGB<26>	440	3520	1233	SEGC<43>
341	7480	1233	SEGC<10>	391	5480	1233	SEGA<26>	441	3480	1233	SEGB<43>
342	7440	1233	SEGB<10>	392	5440	1233	SEGC<27>	442	3440	1233	SEGA<43>
343	7400	1233	SEGA<10>	393	5400	1233	SEGB<27>	443	3400	1233	SEGC<44>
344	7360	1233	SEGC<11>	394	5360	1233	SEGA<27>	444	3360	1233	SEGB<44>
345	7320	1233	SEGB<11>	395	5320	1233	SEGC<28>	445	3320	1233	SEGA<44>
346	7280	1233	SEGA<11>	396	5280	1233	SEGB<28>	446	3280	1233	SEGC<45>
347	7240	1233	SEGC<12>	397	5240	1233	SEGA<28>	447	3240	1233	SEGB<45>
348	7200	1233	SEGB<12>	398	5200	1233	SEGC<29>	448	3200	1233	SEGA<45>
349	7160	1233	SEGA<12>	399	5160	1233	SEGB<29>	449	3160	1233	SEGC<46>
350	7120	1233	SEGC<13>	400	5120	1233	SEGA<29>	450	3120	1233	SEGB<46>

Table 2. Pad Center Coordinates (Continued)

[Unit: μm]

No	X	Y	NAME	No	X	Y	NAME	No	X	Y	NAME
451	3080	1233	SEGA<46>	501	1080	1233	SEGB<63>	551	-920	1233	SEGC<80>
452	3040	1233	SEGC<47>	502	1040	1233	SEGA<63>	552	-960	1233	SEGB<80>
453	3000	1233	SEGB<47>	503	1000	1233	SEGC<64>	553	-1000	1233	SEGA<80>
454	2960	1233	SEGA<47>	504	960	1233	SEGB<64>	554	-1040	1233	SEGC<81>
455	2920	1233	SEGC<48>	505	920	1233	SEGA<64>	555	-1080	1233	SEGB<81>
456	2880	1233	SEGB<48>	506	880	1233	SEGC<65>	556	-1120	1233	SEGA<81>
457	2840	1233	SEGA<48>	507	840	1233	SEGB<65>	557	-1160	1233	SEGC<82>
458	2800	1233	SEGC<49>	508	800	1233	SEGA<65>	558	-1200	1233	SEGB<82>
459	2760	1233	SEGB<49>	509	760	1233	SEGC<66>	559	-1240	1233	SEGA<82>
460	2720	1233	SEGA<49>	510	720	1233	SEGB<66>	560	-1280	1233	SEGC<83>
461	2680	1233	SEGC<50>	511	680	1233	SEGA<66>	561	-1320	1233	SEGB<83>
462	2640	1233	SEGB<50>	512	640	1233	SEGC<67>	562	-1360	1233	SEGA<83>
463	2600	1233	SEGA<50>	513	600	1233	SEGB<67>	563	-1400	1233	SEGC<84>
464	2560	1233	SEGC<51>	514	560	1233	SEGA<67>	564	-1440	1233	SEGB<84>
465	2520	1233	SEGB<51>	515	520	1233	SEGC<68>	565	-1480	1233	SEGA<84>
466	2480	1233	SEGA<51>	516	480	1233	SEGB<68>	566	-1520	1233	SEGC<85>
467	2440	1233	SEGC<52>	517	440	1233	SEGA<68>	567	-1560	1233	SEGB<85>
468	2400	1233	SEGB<52>	518	400	1233	SEGC<69>	568	-1600	1233	SEGA<85>
469	2360	1233	SEGA<52>	519	360	1233	SEGB<69>	569	-1640	1233	SEGC<86>
470	2320	1233	SEGC<53>	520	320	1233	SEGA<69>	570	-1680	1233	SEGB<86>
471	2280	1233	SEGB<53>	521	280	1233	SEGC<70>	571	-1720	1233	SEGA<86>
472	2240	1233	SEGA<53>	522	240	1233	SEGB<70>	572	-1760	1233	SEGC<87>
473	2200	1233	SEGC<54>	523	200	1233	SEGA<70>	573	-1800	1233	SEGB<87>
474	2160	1233	SEGB<54>	524	160	1233	SEGC<71>	574	-1840	1233	SEGA<87>
475	2120	1233	SEGA<54>	525	120	1233	SEGB<71>	575	-1880	1233	SEGC<88>
476	2080	1233	SEGC<55>	526	80	1233	SEGA<71>	576	-1920	1233	SEGB<88>
477	2040	1233	SEGB<55>	527	40	1233	SEGC<72>	577	-1960	1233	SEGA<88>
478	2000	1233	SEGA<55>	528	0	1233	SEGB<72>	578	-2000	1233	SEGC<89>
479	1960	1233	SEGC<56>	529	-40	1233	SEGA<72>	579	-2040	1233	SEGB<89>
480	1920	1233	SEGB<56>	530	-80	1233	SEGC<73>	580	-2080	1233	SEGA<89>
481	1880	1233	SEGA<56>	531	-120	1233	SEGB<73>	581	-2120	1233	SEGC<90>
482	1840	1233	SEGC<57>	532	-160	1233	SEGA<73>	582	-2160	1233	SEGB<90>
483	1800	1233	SEGB<57>	533	-200	1233	SEGC<74>	583	-2200	1233	SEGA<90>
484	1760	1233	SEGA<57>	534	-240	1233	SEGB<74>	584	-2240	1233	SEGC<91>
485	1720	1233	SEGC<58>	535	-280	1233	SEGA<74>	585	-2280	1233	SEGB<91>
486	1680	1233	SEGB<58>	536	-320	1233	SEGC<75>	586	-2320	1233	SEGA<91>
487	1640	1233	SEGA<58>	537	-360	1233	SEGB<75>	587	-2360	1233	SEGC<92>
488	1600	1233	SEGC<59>	538	-400	1233	SEGA<75>	588	-2400	1233	SEGB<92>
489	1560	1233	SEGB<59>	539	-440	1233	SEGC<76>	589	-2440	1233	SEGA<92>
490	1520	1233	SEGA<59>	540	-480	1233	SEGB<76>	590	-2480	1233	SEGC<93>
491	1480	1233	SEGC<60>	541	-520	1233	SEGA<76>	591	-2520	1233	SEGB<93>
492	1440	1233	SEGB<60>	542	-560	1233	SEGC<77>	592	-2560	1233	SEGA<93>
493	1400	1233	SEGA<60>	543	-600	1233	SEGB<77>	593	-2600	1233	SEGC<94>
494	1360	1233	SEGC<61>	544	-640	1233	SEGA<77>	594	-2640	1233	SEGB<94>
495	1320	1233	SEGB<61>	545	-680	1233	SEGC<78>	595	-2680	1233	SEGA<94>
496	1280	1233	SEGA<61>	546	-720	1233	SEGB<78>	596	-2720	1233	SEGC<95>
497	1240	1233	SEGC<62>	547	-760	1233	SEGA<78>	597	-2760	1233	SEGB<95>
498	1200	1233	SEGB<62>	548	-800	1233	SEGC<79>	598	-2800	1233	SEGA<95>
499	1160	1233	SEGA<62>	549	-840	1233	SEGB<79>	599	-2840	1233	SEGC<96>
500	1120	1233	SEGC<63>	550	-880	1233	SEGA<79>	600	-2880	1233	SEGB<96>

Table 2. Pad Center Coordinates (Continued)

[Unit: μm]

No	X	Y	NAME	No	X	Y	NAME	No	X	Y	NAME
601	-2920	1233	SEGA<96>	651	-4920	1233	SEGB<113>	701	-6920	1233	SEGC<130>
602	-2960	1233	SEGC<97>	652	-4960	1233	SEGA<113>	702	-6960	1233	SEGB<130>
603	-3000	1233	SEGB<97>	653	-5000	1233	SEGC<114>	703	-7000	1233	SEGA<130>
604	-3040	1233	SEGA<97>	654	-5040	1233	SEGB<114>	704	-7040	1233	SEGC<131>
605	-3080	1233	SEGC<98>	655	-5080	1233	SEGA<114>	705	-7080	1233	SEGB<131>
606	-3120	1233	SEGB<98>	656	-5120	1233	SEGC<115>	706	-7120	1233	SEGA<131>
607	-3160	1233	SEGA<98>	657	-5160	1233	SEGB<115>	707	-7160	1233	SEGC<132>
608	-3200	1233	SEGC<99>	658	-5200	1233	SEGA<115>	708	-7200	1233	SEGB<132>
609	-3240	1233	SEGB<99>	659	-5240	1233	SEGC<116>	709	-7240	1233	SEGA<132>
610	-3280	1233	SEGA<99>	660	-5280	1233	SEGB<116>	710	-7280	1233	SEGC<133>
611	-3320	1233	SEGC<100>	661	-5320	1233	SEGA<116>	711	-7320	1233	SEGB<133>
612	-3360	1233	SEGB<100>	662	-5360	1233	SEGC<117>	712	-7360	1233	SEGA<133>
613	-3400	1233	SEGA<100>	663	-5400	1233	SEGB<117>	713	-7400	1233	SEGC<134>
614	-3440	1233	SEGC<101>	664	-5440	1233	SEGA<117>	714	-7440	1233	SEGB<134>
615	-3480	1233	SEGB<101>	665	-5480	1233	SEGC<118>	715	-7480	1233	SEGA<134>
616	-3520	1233	SEGA<101>	666	-5520	1233	SEGB<118>	716	-7520	1233	SEGC<135>
617	-3560	1233	SEGC<102>	667	-5560	1233	SEGA<118>	717	-7560	1233	SEGB<135>
618	-3600	1233	SEGB<102>	668	-5600	1233	SEGC<119>	718	-7600	1233	SEGA<135>
619	-3640	1233	SEGA<102>	669	-5640	1233	SEGB<119>	719	-7640	1233	SEGC<136>
620	-3680	1233	SEGC<103>	670	-5680	1233	SEGA<119>	720	-7680	1233	SEGB<136>
621	-3720	1233	SEGB<103>	671	-5720	1233	SEGC<120>	721	-7720	1233	SEGA<136>
622	-3760	1233	SEGA<103>	672	-5760	1233	SEGB<120>	722	-7760	1233	SEGC<137>
623	-3800	1233	SEGC<104>	673	-5800	1233	SEGA<120>	723	-7800	1233	SEGB<137>
624	-3840	1233	SEGB<104>	674	-5840	1233	SEGC<121>	724	-7840	1233	SEGA<137>
625	-3880	1233	SEGA<104>	675	-5880	1233	SEGB<121>	725	-7880	1233	SEGC<138>
626	-3920	1233	SEGC<105>	676	-5920	1233	SEGA<121>	726	-7920	1233	SEGB<138>
627	-3960	1233	SEGB<105>	677	-5960	1233	SEGC<122>	727	-7960	1233	SEGA<138>
628	-4000	1233	SEGA<105>	678	-6000	1233	SEGB<122>	728	-8000	1233	SEGC<139>
629	-4040	1233	SEGC<106>	679	-6040	1233	SEGA<122>	729	-8040	1233	SEGB<139>
630	-4080	1233	SEGB<106>	680	-6080	1233	SEGC<123>	730	-8080	1233	SEGA<139>
631	-4120	1233	SEGA<106>	681	-6120	1233	SEGB<123>	731	-8120	1233	SEGC<140>
632	-4160	1233	SEGC<107>	682	-6160	1233	SEGA<123>	732	-8160	1233	SEGB<140>
633	-4200	1233	SEGB<107>	683	-6200	1233	SEGC<124>	733	-8200	1233	SEGA<140>
634	-4240	1233	SEGA<107>	684	-6240	1233	SEGB<124>	734	-8240	1233	SEGC<141>
635	-4280	1233	SEGC<108>	685	-6280	1233	SEGA<124>	735	-8280	1233	SEGB<141>
636	-4320	1233	SEGB<108>	686	-6320	1233	SEGC<125>	736	-8320	1233	SEGA<141>
637	-4360	1233	SEGA<108>	687	-6360	1233	SEGB<125>	737	-8360	1233	SEGC<142>
638	-4400	1233	SEGC<109>	688	-6400	1233	SEGA<125>	738	-8400	1233	SEGB<142>
639	-4440	1233	SEGB<109>	689	-6440	1233	SEGC<126>	739	-8440	1233	SEGA<142>
640	-4480	1233	SEGA<109>	690	-6480	1233	SEGB<126>	740	-8480	1233	SEGC<143>
641	-4520	1233	SEGC<110>	691	-6520	1233	SEGA<126>	741	-8520	1233	SEGB<143>
642	-4560	1233	SEGB<110>	692	-6560	1233	SEGC<127>	742	-8560	1233	SEGA<143>
643	-4600	1233	SEGA<110>	693	-6600	1233	SEGB<127>	743	-8600	1233	DUMMY<11>
644	-4640	1233	SEGC<111>	694	-6640	1233	SEGA<127>	744	-8640	1233	COM<176>
645	-4680	1233	SEGB<111>	695	-6680	1233	SEGC<128>	745	-8680	1233	COM<175>
646	-4720	1233	SEGA<111>	696	-6720	1233	SEGB<128>	746	-8720	1233	COM<174>
647	-4760	1233	SEGC<112>	697	-6760	1233	SEGA<128>	747	-8760	1233	COM<173>
648	-4800	1233	SEGB<112>	698	-6800	1233	SEGC<129>	748	-8800	1233	COM<172>
649	-4840	1233	SEGA<112>	699	-6840	1233	SEGB<129>	749	-8840	1233	COM<171>
650	-4880	1233	SEGC<113>	700	-6880	1233	SEGA<129>	750	-8880	1233	COM<170>

Table 2. Pad Center Coordinates (Continued)

[Unit: μm]

No	X	Y	NAME	No	X	Y	NAME
751	-8920	1233	COM<169>	801	-10120	160	COM<121>
752	-8960	1233	COM<168>	802	-10120	120	COM<120>
753	-9000	1233	COM<167>	803	-10120	80	COM<119>
754	-9040	1233	COM<166>	804	-10120	40	COM<118>
755	-9080	1233	COM<165>	805	-10120	0	COM<117>
756	-9120	1233	COM<164>	806	-10120	-40	COM<116>
757	-9160	1233	COM<163>	807	-10120	-80	COM<115>
758	-9200	1233	COM<162>	808	-10120	-120	COM<114>
759	-9240	1233	COM<161>	809	-10120	-160	COM<113>
760	-9280	1233	COM<160>	810	-10120	-200	COM<112>
761	-9320	1233	COM<159>	811	-10120	-240	COM<111>
762	-9360	1233	COM<158>	812	-10120	-280	COM<110>
763	-9400	1233	COM<157>	813	-10120	-320	COM<109>
764	-9440	1233	COM<156>	814	-10120	-360	COM<108>
765	-9480	1233	COM<155>	815	-10120	-400	COM<107>
766	-9520	1233	COM<154>	816	-10120	-440	COM<106>
767	-9560	1233	COM<153>	817	-10120	-480	COM<105>
768	-9600	1233	COM<152>	818	-10120	-520	COM<104>
769	-9640	1233	COM<151>	819	-10120	-560	COM<103>
770	-9680	1233	COM<150>	820	-10120	-600	COM<102>
771	-9720	1233	COM<149>	821	-10120	-640	COM<101>
772	-9760	1233	COM<148>	822	-10120	-680	COM<100>
773	-9800	1233	COM<147>	823	-10120	-720	COM<99>
774	-9840	1233	COM<146>	824	-10120	-760	COM<98>
775	-9880	1233	COM<145>	825	-10120	-800	COM<97>
776	-9920	1233	COM<144>	826	-10120	-840	COM<96>
777	-9960	1233	DUMMY<12>	827	-10120	-880	COM<95>
778	-10120	1080	DUMMY<13>	828	-10120	-920	COM<94>
779	-10120	1040	COM<143>	829	-10120	-960	COM<93>
780	-10120	1000	COM<142>	830	-10120	-1000	COM<92>
781	-10120	960	COM<141>	831	-10120	-1040	COM<91>
782	-10120	920	COM<140>	832	-10120	-1080	COM<90>
783	-10120	880	COM<139>	833	-10120	-1120	COM<89>
784	-10120	840	COM<138>	834	-10120	-1160	COM<88>
785	-10120	800	COM<137>	835	-10120	-1200	COM<87>
786	-10120	760	COM<136>	836	-10120	-1240	DUMMY<14>
787	-10120	720	COM<135>				
788	-10120	680	COM<134>				
789	-10120	640	COM<133>				
790	-10120	600	COM<132>				
791	-10120	560	COM<131>				
792	-10120	520	COM<130>				
793	-10120	480	COM<129>				
794	-10120	440	COM<128>				
795	-10120	400	COM<127>				
796	-10120	360	COM<126>				
797	-10120	320	COM<125>				
798	-10120	280	COM<124>				
799	-10120	240	COM<123>				
800	-10120	200	COM<122>				

PIN DESCRIPTION

Table 3. Power Supply Pins

Name	I/O	Description
VDD3	Supply	Main power supply
VDD3R	Supply	Internal regulator power supply This pin is connected to VDD3.
VDD	Supply	Regulated power supply input pin for internal digital and DDRAM block. This pin is connected to REG_OUT outside the chip with stabilization capacitor. When the internal regulator is not used, VDD1 should be tied to VDD directly.
VDDO	Supply	Internal oscillator power supply This pin is connected to VDD.
VSS VSSO VSSA VSSB	GND	Ground
V1IN	I	LCD segment high selected driving voltage input pin
V1OUT	O	LCD segment high driving voltage output pin
VMIN	I	LCD common/segment non-selected driving voltage input pin
VMOUT	O	LCD common/segment non-selected driving voltage output pin
V0IN	I	LCD segment low selected driving voltage input pin
VCC	I	LCD common high selected driving voltage input pin
VRP	O	LCD common high selected driving voltage output pin
VEE VEES	I	LCD common low selected driving voltage input pin The relationship between VCC, V1, VM, V0 and VEE: $VCC > V1 > VM > V0(=VSS) > VEE$ ($V1 - VM = VM - V0$, $VCC - VM = VM - VEE$)
VRN	O	LCD common low selected driving voltage output pin
VIN1 VIN1A	I	Power supply for 1' st booster circuit and VM amp
VIN2	I	Power supply for 2' nd booster circuit
VOUT45	O	1' st booster output pin
VIN45	I	Power supply for V1. Connect to VOUT45 or VIN1
C11P C11M C12P C12M	O	External capacitor connection pins used for 1' st booster circuit
V1T	I	Thermistor resistor connection pin
INTRS	I	External resistor select pin for temperature compensation circuit - INTRS = L : External resistor mode, INTRS = H : Internal resistor mode
DC2IN	I	Power supply for 2' nd booster. Connect to DC2OUT pin
DC2OUT	O	Power output pin for 2' nd booster input
C21P C21M C22P C22M C23P C23M C24P C24M	O	External capacitor connection pins used for 2' nd booster circuit
C31P C31M	O	External capacitor connection pins used for 3' rd booster circuit

Table 4. MPU Interface Pins

Name	I/O	Description				
RSTB	I	Reset input pin. When RSTB is "L", initialization is executed.				
PS MPU[1:0]	I	MPU interface select pin				
		PS	MPU[1]	MPU[0]	Description	
		H	L	L	8080-series 8bit interface	
		H	L	H	8080-series 16bit interface	
		H	H	L	6800-series 8bit interface	
		H	H	H	6800-series 16bit interface	
		L	L	X	3 pin SPI(Write only)	
		L	H	X	4 pin SPI(Write only)	
CS1B CS2	I	Chip select input pins Data / instruction I/O is enabled only when CS1B is "L" and CS2 is "H". When chip select is non-active, DB0 to DB15 may be high impedance.				
D/I (RS)	I	Data / Instruction select input pin – D/I = "H": DB0 to DB15 are display data – D/I = "L": DB0 to DB7 are instruction data				
WRB (R/W)	I	Read / Write execution control pin				
		PS	MPU	MPU Type	WRB	Description
		H	H	6800-series	R/W	ReadWRBite control input pin – R/W = "H": read – R/W = "L": write
H	L	8080-series	WRB	Write enable clock input pin The data on DB0 to DB15 are latched at the rising edge of the WRB signal.		
RDB (E)	I	Read / Write execution control pin				
		MPU[1]	MPU type	RDB	Description	
		H	6800-series	E	Read / Write control input pin – R/W = "H": When E is "H", DB0 to DB15 are in an output status. – R/W = "L": The data on DB0 to DB15 are latched at the falling edge of the E signal.	
L	8080-series	RDB	Read enable clock input pin When RDB is "L", DB0 to DB15 are in an output status.			
DB[15:8] DB[7]/SDI DB[6]/SCL DB[5:0]	I/O	-DB[15:0]: 16-bit bi-directional data bus. -SDI: Serial data input pin. The data is latched at the rising edge of SCL. -SCL: Serial clock input pin.				
CDIR	I	Common direction select pin.				



Table 5. Oscillator and Power Regulator Pins

Name	I/O	Description
OSC1 OSC2 OSC3 OSC4	O	CR oscillator output pin When the internal CR oscillator is used, connect to OSC1, OSC3 through a resistor. OSC1 – OSC2: Using in normal display mode, partial display mode 0 OSC3 – OSC4: Using in partial display mode 1 When an external oscillator is used, OSC1 pin is connected to VDD or VSS.
OSC5	I	External clock input pin When an external input is used, it is input to this pin. But the internal oscillator is used, this pin is connected to VDD or VSS.
REG_ENB	I	Internal regulator enable/disable input pin - REG_ENB = "L" (tied to VSS) : enable internal regulator - REG_ENB = "H" (tied to VDD) : disable internal regulator
REG_OUT	O	Internal voltage regulator output pin The regulator output port from this pin is used as a power supplier for an internal digital block via VDD pins.

Table 6. Timing signal Pins for monitoring

Name	I/O	Description
CL	O	Shift clock output pin
PM	O	Field delimiter output pin
FR	O	Liquid crystal alternating current output pin

Table 7. LCD driver output pins

Name	I/O	Description
SEGA0 to 143	O	LCD driving segment output (Red or Blue)
SEGB0 to 143	O	LCD driving segment output (Green)
SEGC0 to 143	O	LCD driving segment output (Blue or Red)
COM0 to 176	O	LCD common outputs

Table 8. Test pins

Name	I/O	Description
TEST[2:0]	I	Don't use these pins. IC maker's test pins These pins must be tied to VDD.

FUNCTIONAL DESCRIPTION

MPU INTERFACE

Chip Select Input

There are CS1B and CS2 pins for chip selection. The S6B33B0A can interface with an MPU only when CS1B is "L" and CS2 is "H". When these pins are set to any other combination, D/I, RDB, and WRB inputs are disabled and DB0 to DB15 are to be high impedance. And, in case of serial interface, the internal shift register and the counter are reset.

Parallel/Serial Interface

The S6B33B0A has four types of interface with an MPU, which are two serial and two parallel interfaces. This parallel or serial interface is determined by PS pin as shown in Table9.

Table 9. Parallel / Serial Interface Mode.

PS	MPU[1]	CS1B	CS2	MPU bus type
H	L	CS1B	CS2	8080-Series MPU
	H			6800-Series MPU
L	L	CS1B	CS2	3-Pin SPI
	H			4-Pin SPI

Parallel Interface (PS="H")

The 8-bit/16-bit bi-directional data bus is used in parallel interface. The type of MPU is selected by MPU[1] and the mode of data-bus is controlled by MPU[0] as shown in below. In accessing internal registers (D/I = "L"), only DB[7:0] are valid.

Table 10. Microprocessor Selection for Parallel Interface

MPU[1]	MPU[0]	CS1B	CS2	RDB	WRB	Data Bus	MPU bus type
L	L	CS1B	CS2	RDB	WRB	DB[7:0]	8080-series MPU
	H					DB[15:0]	
H	L	CS1B	CS2	E	R/W	DB[7:0]	6800-series MPU
	H					DB[15:0]	

Table 11. Parallel Data Transfer

D/I	6800-series		8080-series		Description
	RDB	WRB	RDB	WRB	
H	H	H	L	H	Read display data
H	H	L	H	L	Write display data
L	H	H	L	H	Read out internal status register
L	H	L	H	L	Write instruction data

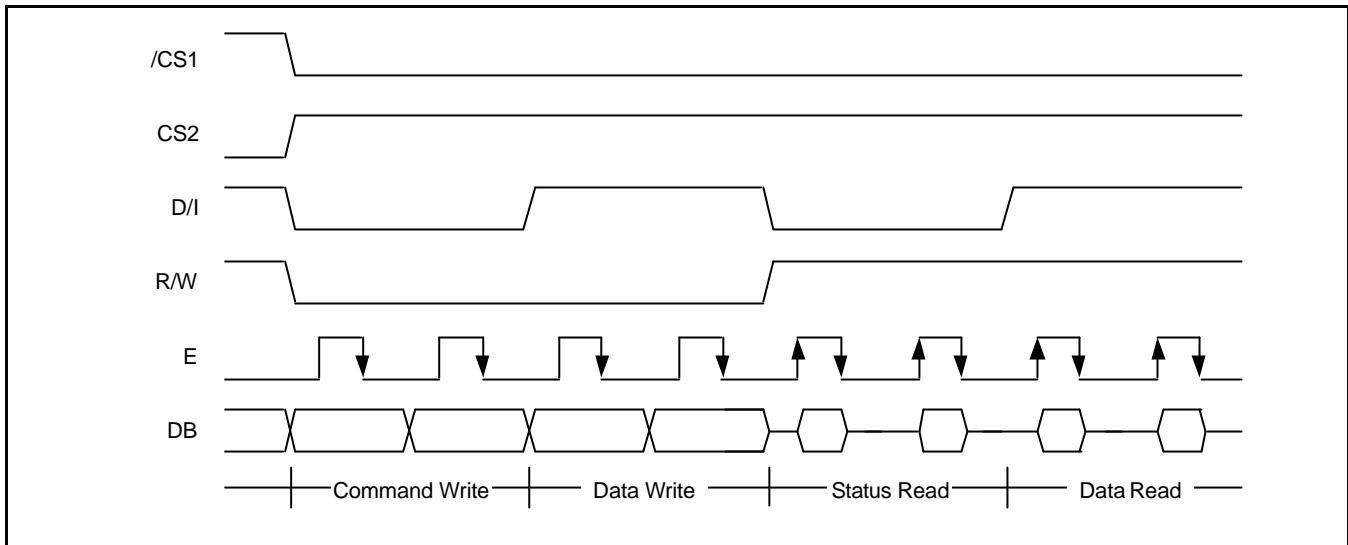

Figure 6. 6800-Series MPU Interface protocol (MPU[1]="H")

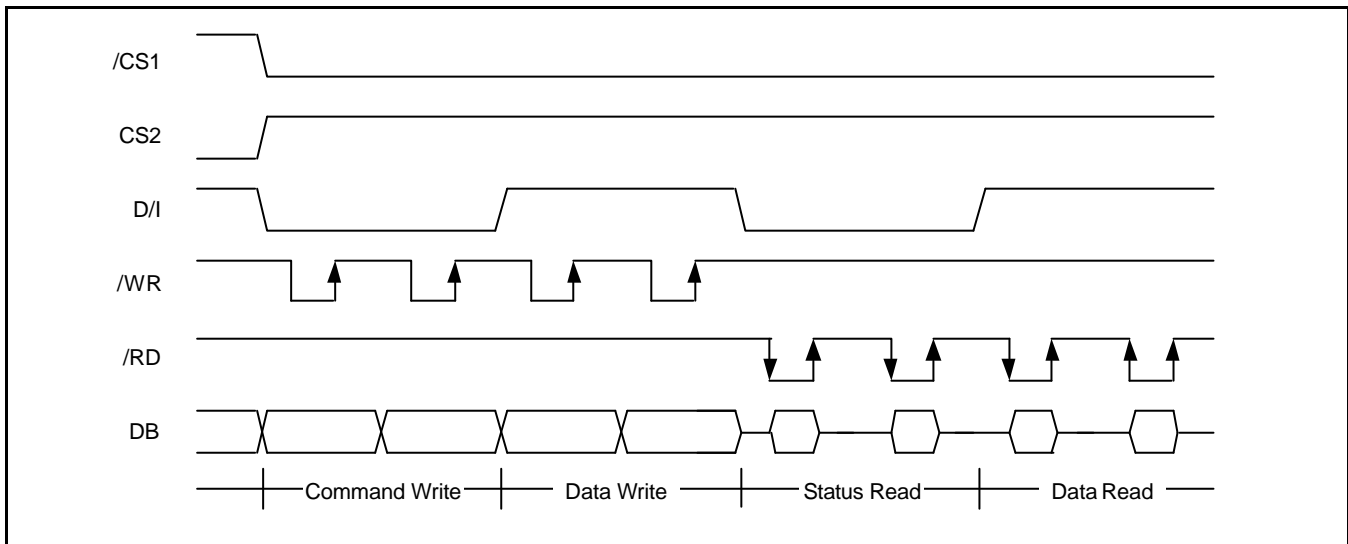

Figure 7. 8080-Series MPU Interface Protocol (MPU[1]="L")

Serial Interface(PS="L")

Communication with the microprocessor occurs via a clock-synchronized serial peripheral interface when PS is low. When using the serial interface, read operations are not allowed. When the chip select inputs are valid (CS1B = "L" & CS2 = "H"), the serial data is sent most significant bit first on the rising edge of a serial clock going into DB6 and processed as 8 bit parallel data on the eighth clock. Since the clock signal is easy to be affected by the external noise caused by the line length, the operation check on the actual machine is recommended. And Invalid, the internal shift register and the counter are reset.

The serial interface type is selected by setting PS as shown in Table12.

Table 12. Microprocessor Selection for Serial Interface

PS	MPU[1]	CS1B	CS2	D/I	Serial Data	Serial Clock	SPI Mode
L	L	CS1B	CS2	By S/W	DB[7]	DB[6]	3-Pin
	H	CS1B	CS2	D/I			4-Pin

3-Pin SPI Interface (PS = "L" & MPU[1] = "L")

In 3-Pin SPI Interface mode, the pre-defined instruction called Display Data Length is used to indicate whether serial data input is display or instruction data instead of D/I pin. The data is handled as instruction data until the Display Data Length instruction is issued. This Display Data Length instruction consists of three bytes instruction. The first byte instruction enables the next instruction to be valid, and data of the second two bytes indicate that a specified number of display data bytes(1 to 65536) are to be transmitted. Next two bytes after the display data string is handled as instruction data. For details, refer the Figure 8.

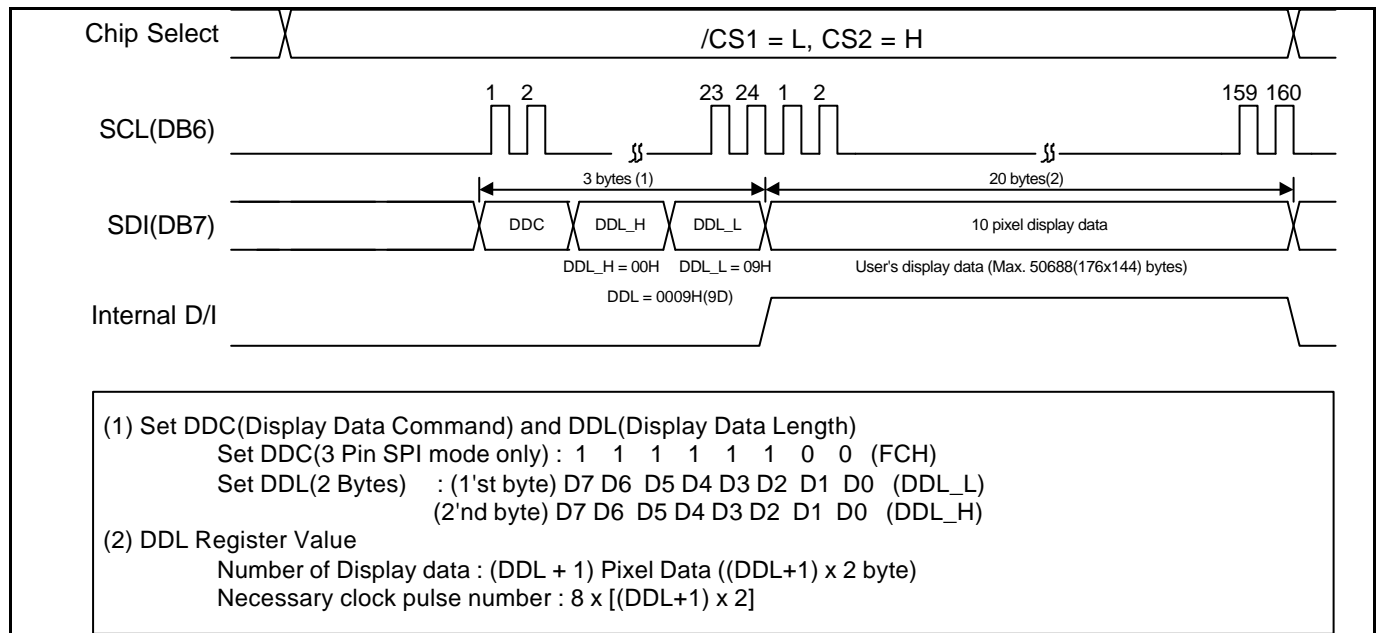

Figure 8. 3-Pin SPI Timing (D/I is not used)

4-Pin Serial Interface (PS="L" & MPU[1]="H")

In 4-pin SPI interface mode, D/I pin is used for indicating whether serial data input is display or instruction data. Data is display data when D/I is high and instruction data when D/I is low. Serial data can be read on the rising edge of serial clock going into DB6 and processed as 8-bit parallel data on the eighth serial clock.

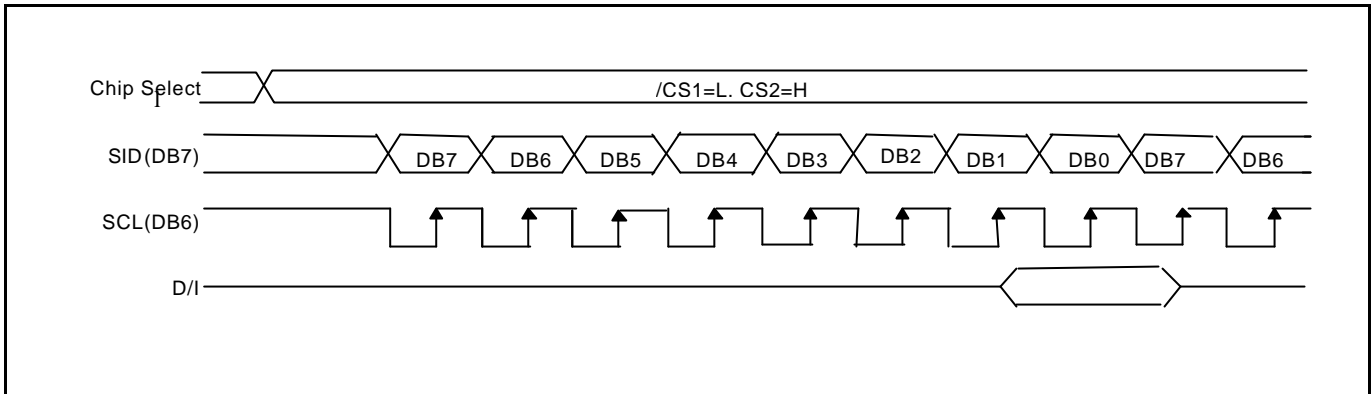

Figure 9. 4-Pin Serial Interface Timing

DISPLAY DATA RAM

The on-chip display data RAM of S6B33B0A is a static RAM that is stored the data for the display. It is a 2,304 x 176 structure. It is controlled by 2 addresses, X and Y. And, RAM area selection and automatic address count up functions are accomplished by the internal instructions.

DDRAM Address Area Selection

A part of DDRAM address area of S6B33B0A can be accessed by X and Y address area settings. After setting RAM area, the addresses become the start address.

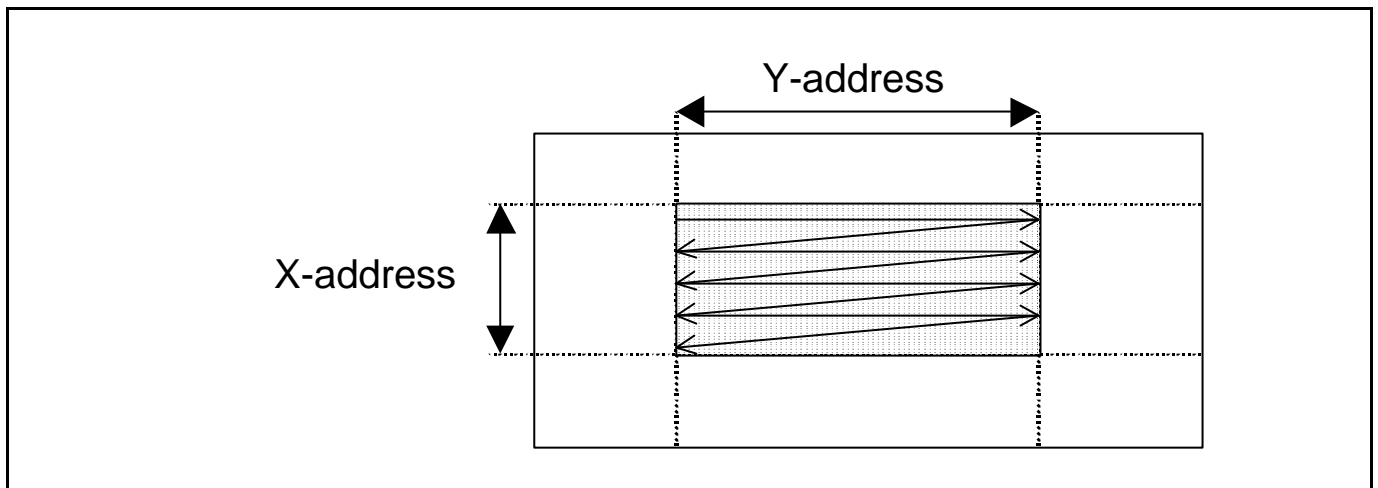

Figure 10. DDRAM Address Area

Table 13. X address Control

	DB7	DB6	DB5	DB4	DB3	DB2	DB1	DB0
Code	0	0	1	0	0	0	0	1
P1	X start address set(Initial Status = 00H)							
P2	X end address set(Initial Status = AFH)							

Table 14. Y address Control

	DB7	DB6	DB5	DB4	DB3	DB2	DB1	DB0
Code	0	0	1	1	0	0	0	1
P1	Y start address set (Initial status = 00H)							
P2	Y end address set (Initial status =8FH)							

RAM Addressing Count up

By selecting the X address and Y address area by the internal instructions, the address counts up from its start address to end address after data access operation. When one address is equal to the end address, it returns to the start address. At this time, the other address is increased by 1.

Y address count mode (Y address = 00h to 8Fh, X address = 00h to AFh)

		Y-address									
		00h	01h	02h	03h	04h	05h	06h	07h	08h	8Fh
X-address	00h	1	2	3	4	5	6	7	8	9	144
	01h	145									288
	02h	289									432
	03h	433									576
	AFh	25201									

Figure 11. Y address count mode

X address count mode (Y address = 00h to 8Fh, X address = 00h to AFh)

		Y-address									
		00h	01h	02h	03h	04h	05h	06h	07h	08h	8Fh
X-address	00h	1	177	324	486	648	810	972	1134	1296	21222
	01h	2									
	02h	3									
	03h	4									
	AFh	176	352	528	704	880	1056	1232	1408	1584	25344

Figure 12. X address count mode

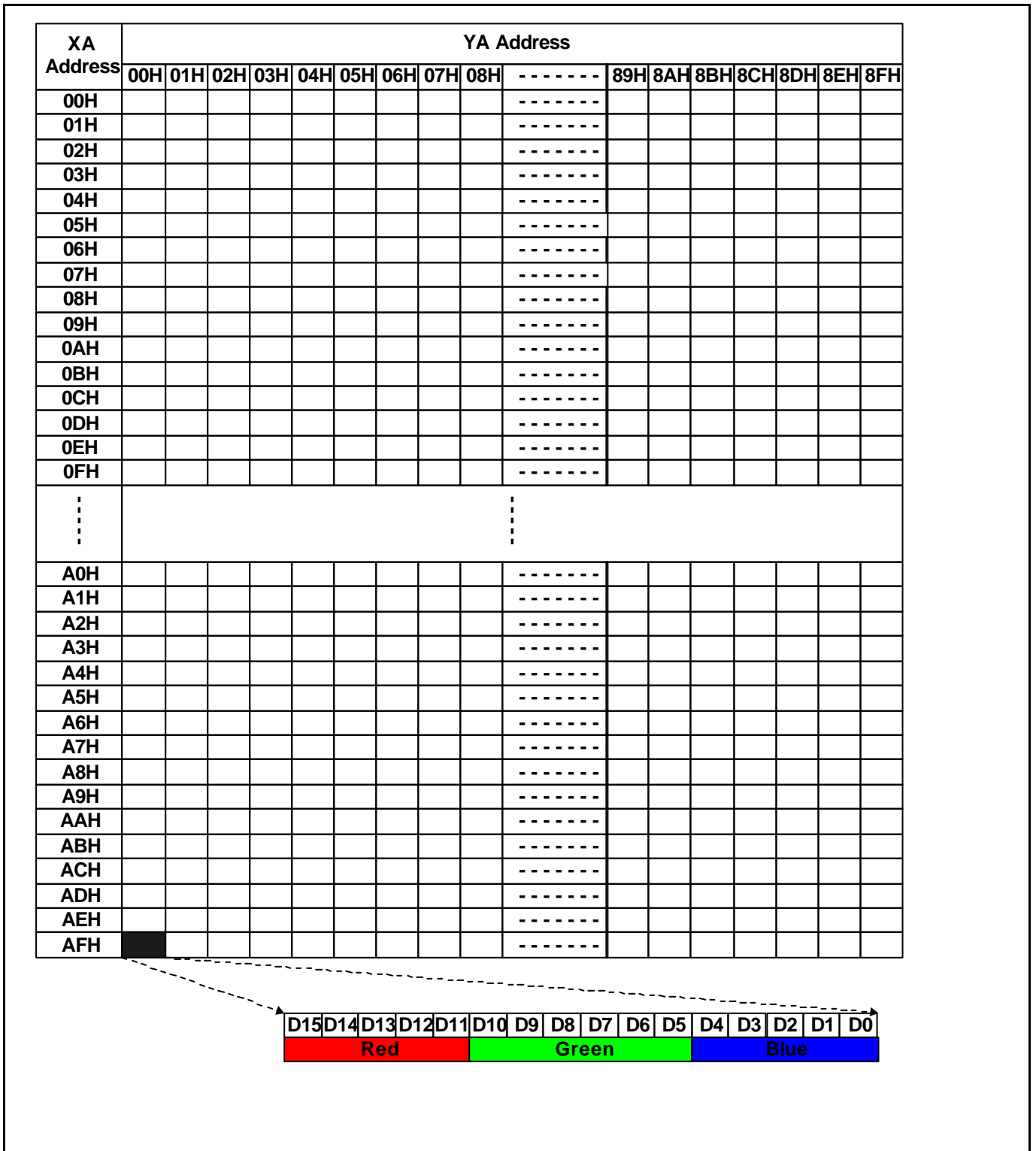

Figure 13. Display Data RAM Map

Partial Display Mode

The S6B33B0A realizes the partial display function with low duty driving for saving power consumption and showing the various display duties. It is set as display start/end line number.

Area Scroll Function

The S6B33B0A realizes the specific area scroll function. (1/176 duty case).

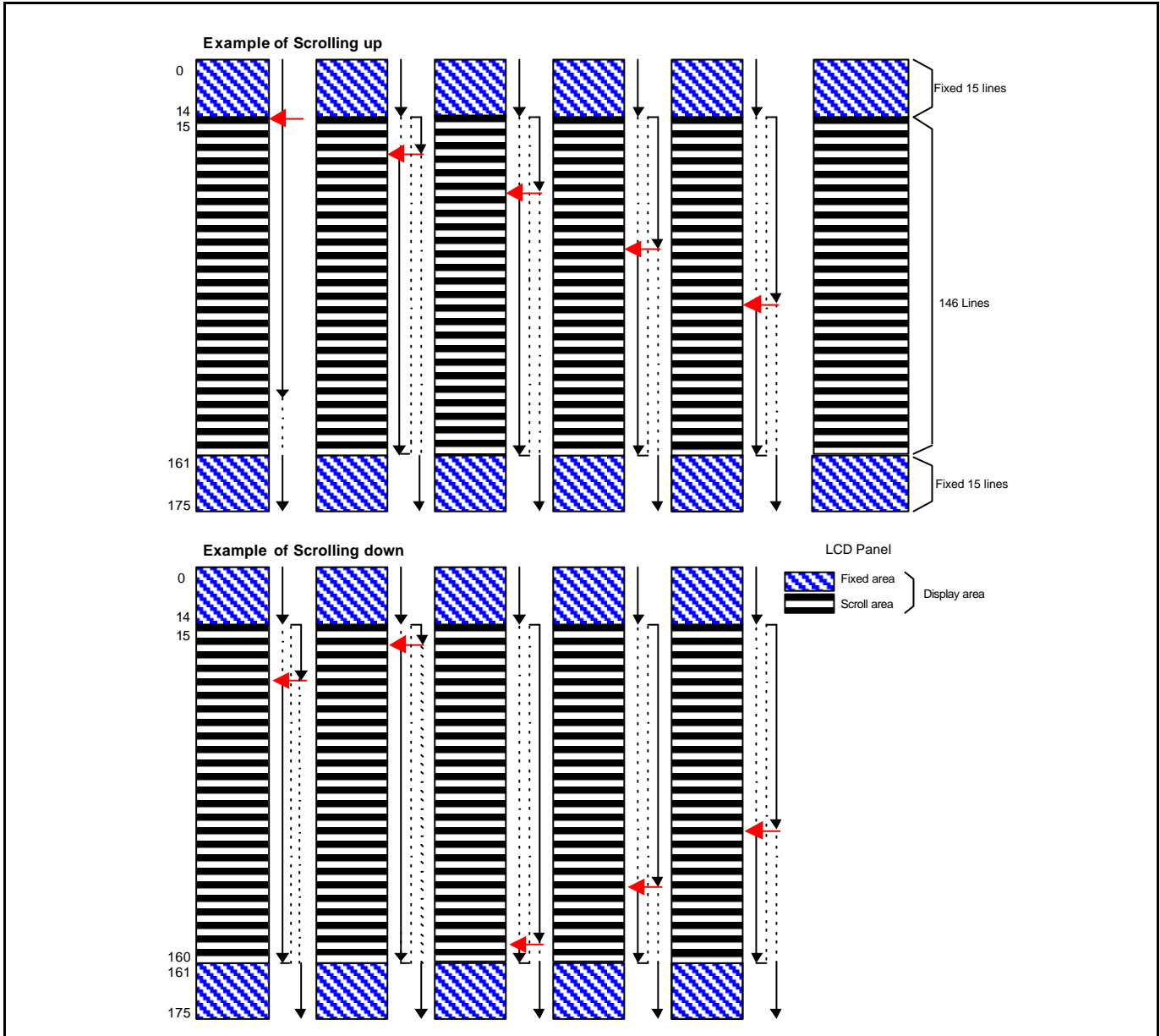

Figure 14. Area scroll examples (duty = 1/176, center scroll mode)

Display Direction

SDIR

The SDIR flag of Driver Output Mode Set instruction selects the direction of segment display.

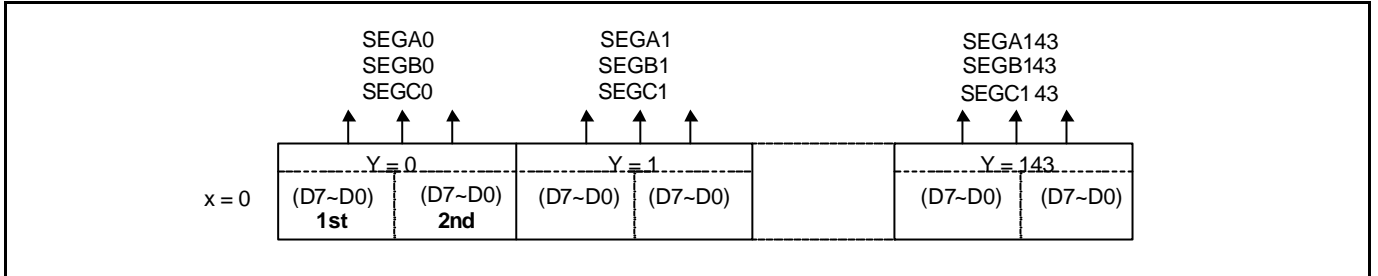

Figure 15. 8-bit data bus mode when SDIR = L

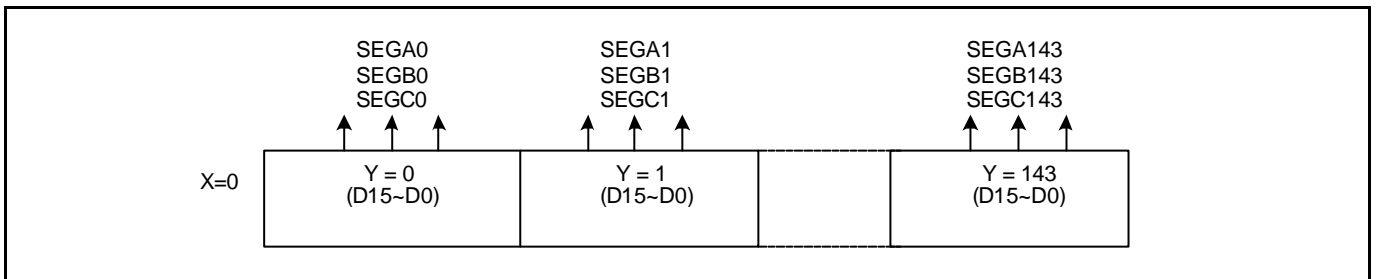

Figure 16. 16-bit data bus mode when SDIR = L

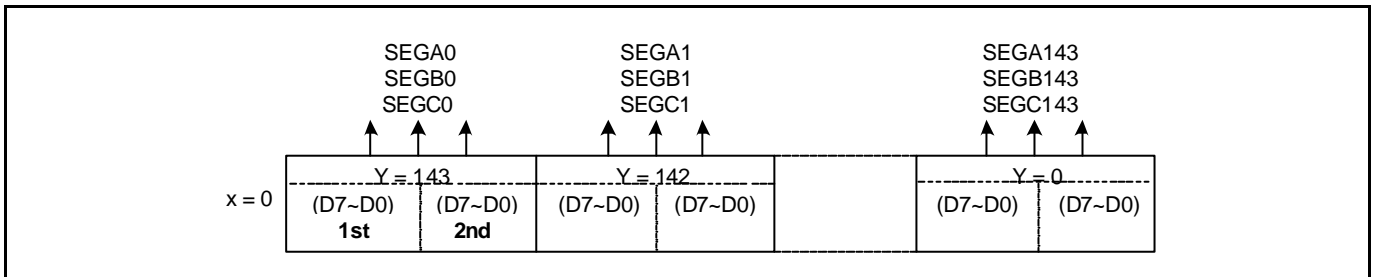

Figure 17. 8-bit data bus mode when SDIR = H

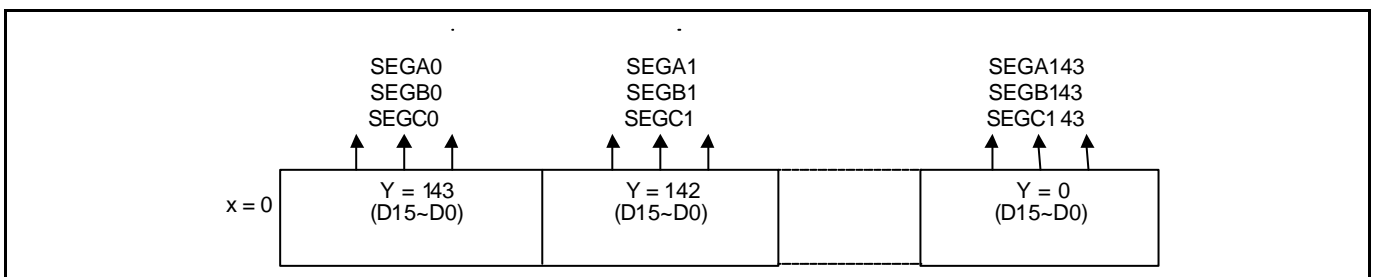
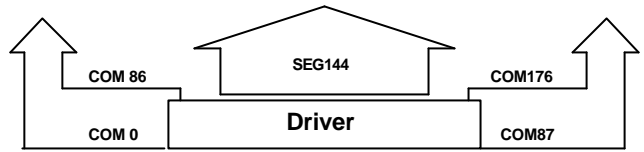

Figure 18. 16-bit data bus mode when SDIR = H

CDIR

The direction of common scanning is selected by CDIR pin.



128 Display Lines (DLN=00)

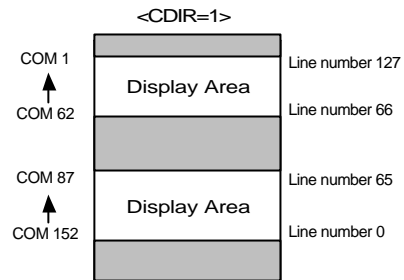
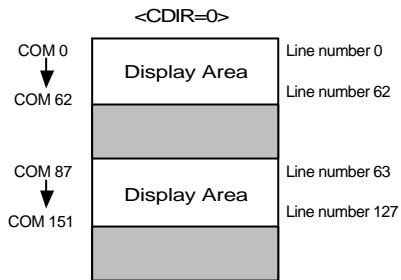

144 Display Lines (DLN=01)

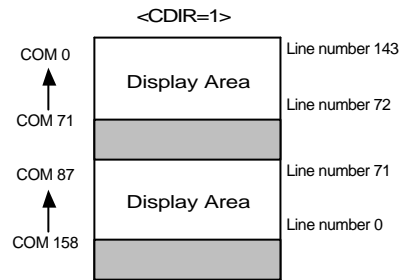
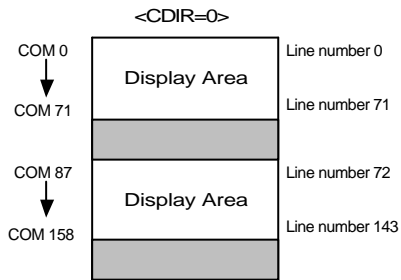

160 Display Lines (DLN=10)

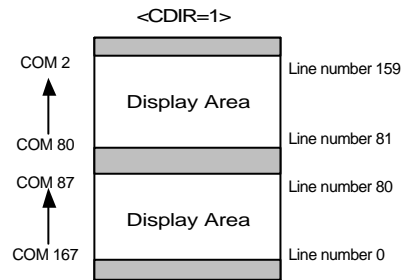
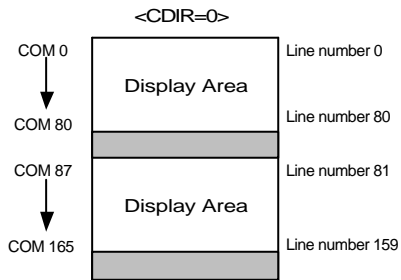

176 Display Lines (DLN=11)

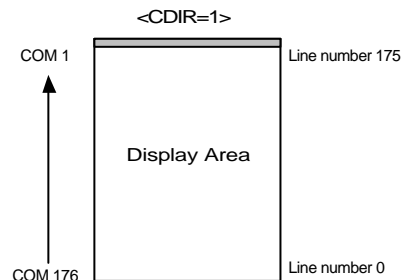
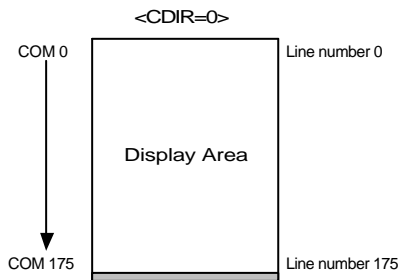

SWP

The SWP flag of Driver Output Mode Set instruction selects the swapping of segment display.

SWP=1

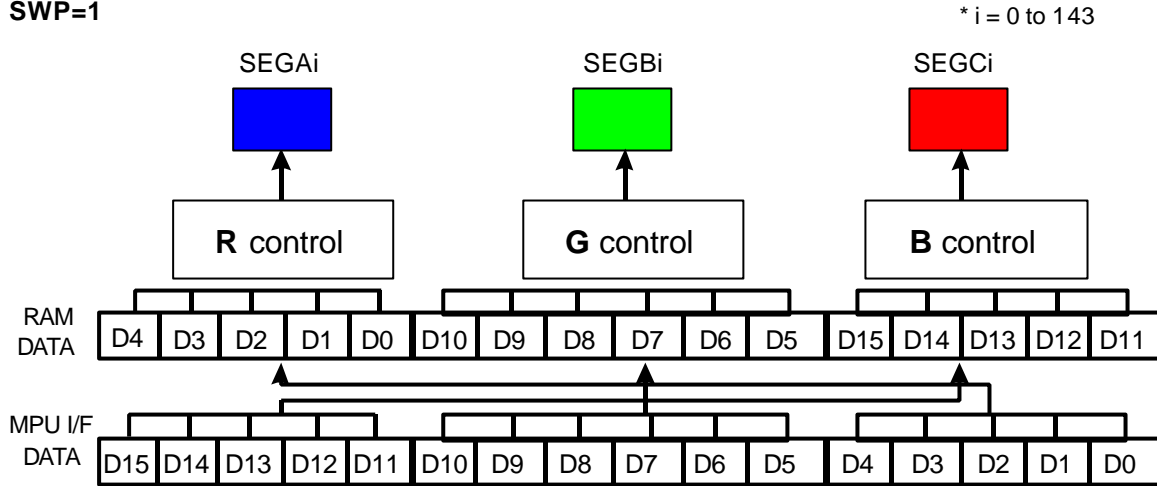

SWP=0

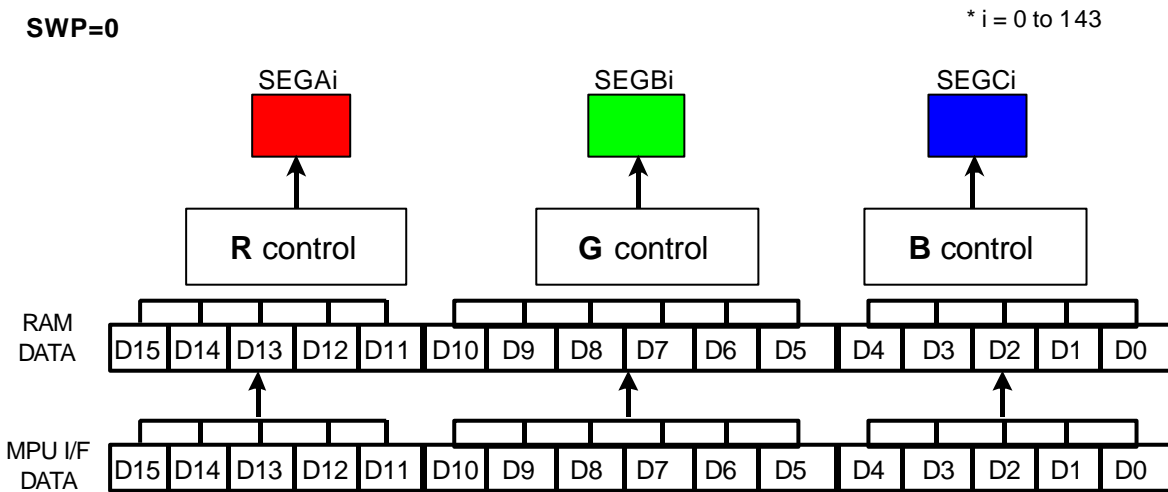

	SEGAi	SEGBi	SEGCi	
SWP = 0	RED	GREEN	BLUE	Color
	D15 ~ D11	D10 ~ D5	D4 ~ D0	Assigned Bit
SWP = 1	BLUE	GREEN	RED	Color
	D4 ~ D0	D10 ~ D5	D15 ~ D11	Assigned Bit

Figure 19. The relationship between SEG outputs and RGB color

On-Chip Regulator Configuration

The output voltage of regulator circuit(REG_OUT) is ranging from 1.8V to 2.2V and nominal value is 1.8V.

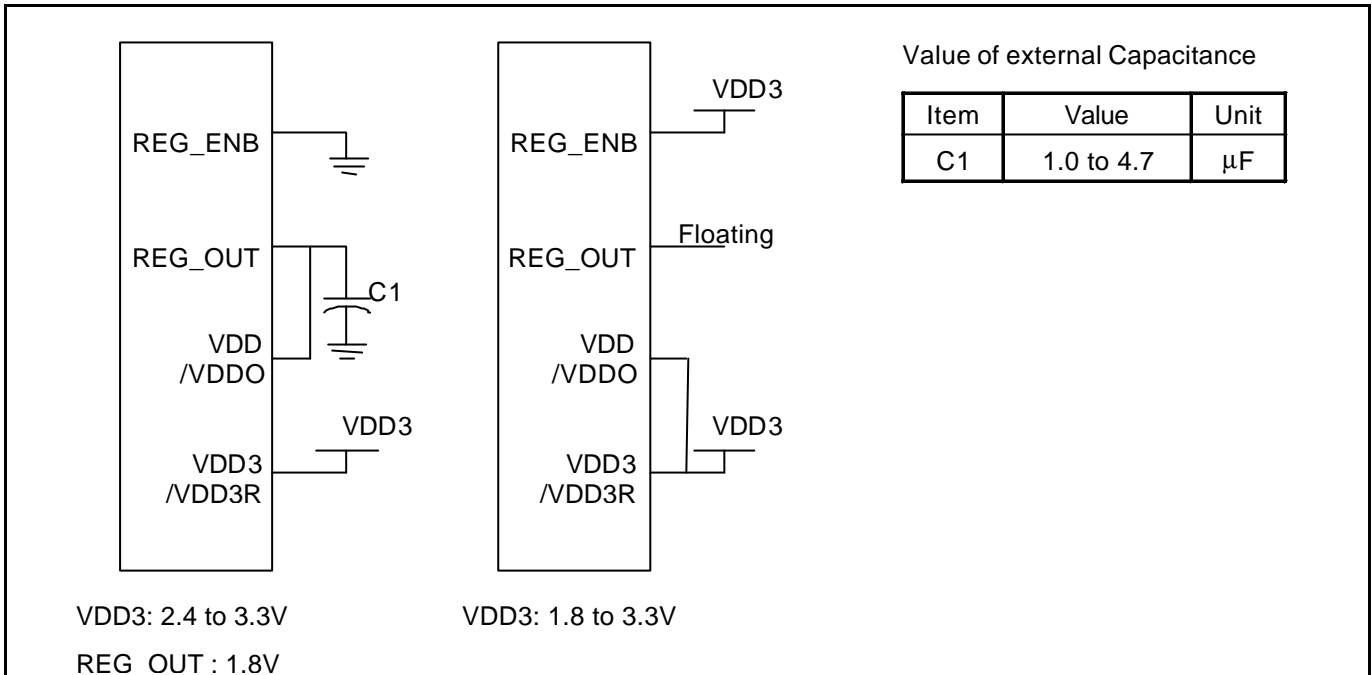

Figure 20. Regulator Application

Oscillator Circuit

When internal oscillator is used(EXT=0), the selection of oscillator resistor is determined by display mode.

- Normal display mode/ Partial display mode 0 : resistor1 between OSC1 and OSC2
- Partial display mode 1 : resistor2 between OSC3 and OSC4

When external clock is used (EXT=1), clock frequency should be adjusted to display mode which is selected.

Example of external oscillator application

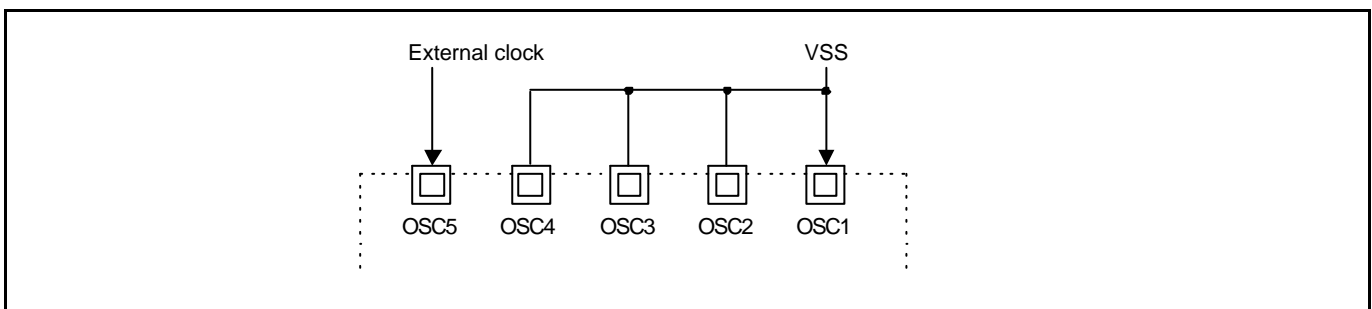
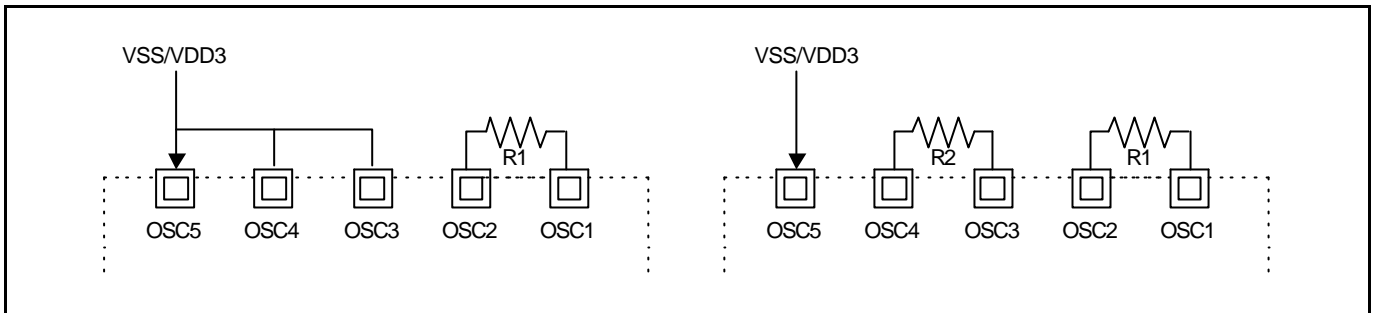

Figure 21. External oscillator application

Example of internal oscillator application



When partial display mode 1 is not used.

When partial display mode 1 is used.

Figure 22. Internal oscillator application

Discharge Circuit

Driving voltage level discharge time at standby ON.

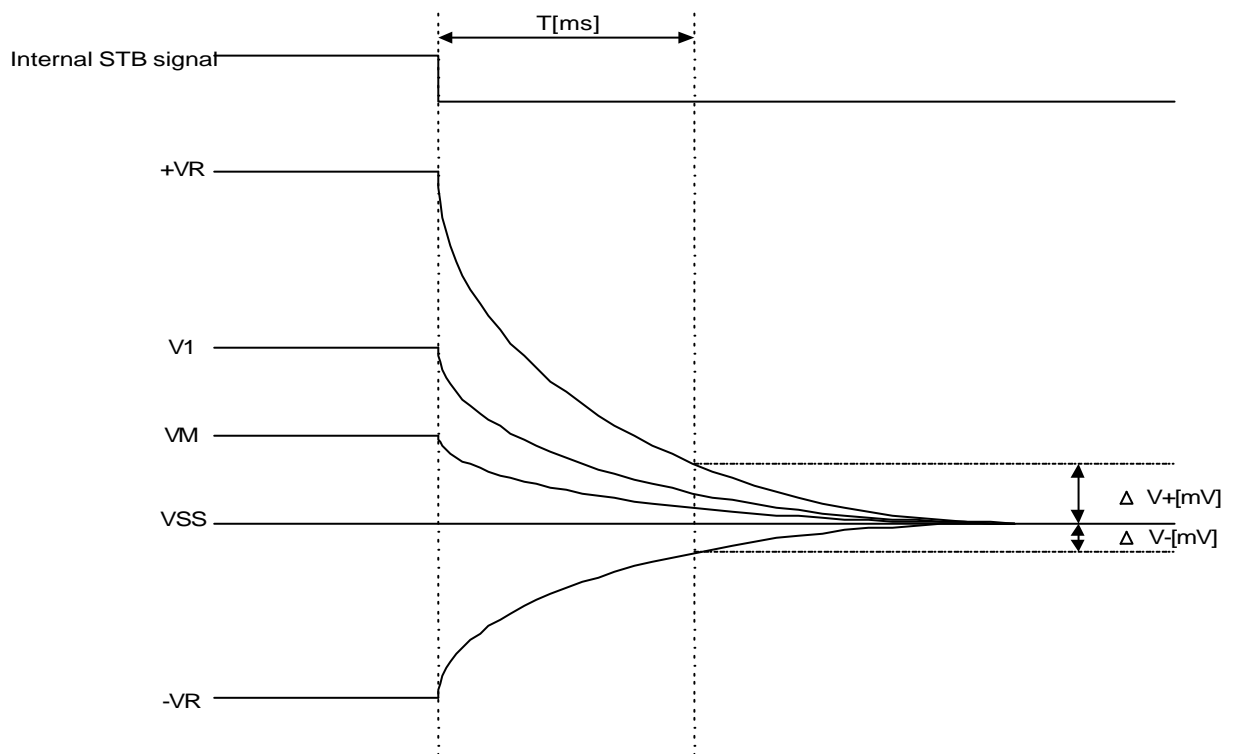

The relation between voltage level and discharge time from when “Standby ON” command is inputted.

LEVEL	CONDITION	T[ms]	$\Delta V+, \Delta V- [mV]$
+VR, V1, VM, -VR	+VR=12.0V, V1=3.0V, VM=1.5V, -VR=-9.0V at T=0	100	< 50
		300	< 20

INSTRUCTION DESCRIPTION

Table 15. Instruction Table

Instruction Name	D/I	WRB	RDB	DB15 ~DB8	DB7	DB6	DB5	DB4	DB3	DB2	DB1	DB0	Hex.	Parameter
Non Operation	0	0	1	*	0	0	0	0	0	0	0	0	00	
Oscillation Mode Set	0	0	1	*	0	0	0	0	0	0	1	0	02	1Byte
Driver Output Mode Set	0	0	1	*	0	0	0	1	0	0	0	0	10	1Byte
DC-DC Select	0	0	1	*	0	0	1	0	0	0	0	0	20	1Byte
Bias Set	0	0	1	*	0	0	1	0	0	0	1	0	22	1Byte
DCDC Clock Division Set	0	0	1	*	0	0	1	0	0	1	0	0	24	1Byte
DCDC and AMP ON/OFF set	0	0	1	*	0	0	1	0	0	1	1	0	26	1Byte
Temperature Compensation Set	0	0	1	*	0	0	1	0	1	0	0	0	28	1Byte
Contrast Control(1)	0	0	1	*	0	0	1	0	1	0	1	0	2A	1Byte
Contrast Control(2)	0	0	1	*	0	0	1	0	1	0	1	1	2B	1Byte
Standby Mode OFF	0	0	1	*	0	0	1	0	1	1	0	0	2C	-
Standby Mode ON	0	0	1	*	0	0	1	0	1	1	0	1	2D	-
DDRAM Burst Mode OFF	0	0	1	*	0	0	1	0	1	1	1	0	2E	-
DDRAM Burst Mode ON	0	0	1	*	0	0	1	0	1	1	1	1	2F	-
Addressing Mode Set	0	0	1	*	0	0	1	1	0	0	0	0	30	1Byte
ROW Vector Mode Set	0	0	1	*	0	0	1	1	0	0	1	0	32	1Byte
N-line Inversion Set	0	0	1	*	0	0	1	1	0	1	0	0	34	1Byte
Entry Mode Set	0	0	1	*	0	1	0	0	0	0	0	0	40	1Byte
X-address Area Set	0	0	1	*	0	1	0	0	0	0	1	0	42	2Byte
Y-address Area Set	0	0	1	*	0	1	0	0	0	0	1	1	43	2Byte
RAM Skip Area Set	0	0	1	*	0	1	0	0	0	1	0	1	45	1Byte
Display OFF	0	0	1	*	0	1	0	1	0	0	0	0	50	-
Display ON	0	0	1	*	0	1	0	1	0	0	0	1	51	-
Specified Display Pattern Set	0	0	1	*	0	1	0	1	0	0	1	1	53	1Byte
Partial Display Mode Set	0	0	1	*	0	1	0	1	0	1	0	1	55	1Byte
Partial Display Start Line Set	0	0	1	*	0	1	0	1	0	1	1	0	56	1Byte
Partial Display End Line Set	0	0	1	*	0	1	0	1	0	1	1	1	57	1Byte
Area Scroll Mode Set	0	0	1	*	0	1	0	1	1	0	0	1	59	4Byte
Scroll Start Line Set	0	0	1	*	0	1	0	1	1	0	1	0	5A	1Byte
Set Display Data Length	X	X	X	*	1	1	1	1	1	1	0	0	FC	1Byte
Display Data Write	1	0	1		Display Data Write							-	-	
Display Data Read	1	1	0		Display Data Read							-	-	
Status Read	0	1	0	0	Status Data Read							-	-	
Test Mode1	0	0	1	*	1	1	1	1	1	1	1	1	FF	-
Test Mode2	0	0	1	*	1	1	1	1	1	1	1	0	FE	-
Test Mode3	0	0	1	*	1	1	1	1	1	1	0	1	FD	-
Test Mode4	0	0	1	*	1	1	1	1	1	0	1	1	FB	-
Test Mode5	0	0	1	*	1	1	1	1	1	0	1	0	FA	-
Test Mode6	0	0	1	*	1	1	1	1	1	0	0	1	F9	-

*: Don' t care

Parameter: The number of parameter bytes that follows instruction data.

Non Operation (00H)

This instruction is Non operation.

D/I	WRB	RDB	DB7	DB6	DB5	DB4	DB3	DB2	DB1	DB0
0	0	1	0	0	0	0	0	0	0	0

Oscillation Mode Set (02H)

Setting internal function mode.

D/I	WRB	RDB	DB7	DB6	DB5	DB4	DB3	DB2	DB1	DB0
0	0	1	0	0	0	0	0	0	1	0
			0	0	0	0	0	0	0	EXT

EXT: External clock selecting

EXT = 0: Internal clock mode (Initial status)

EXT = 1: External clock mode

OSC: Internal oscillator ON/OFF

OSC = 0: Internal oscillator OFF(Initial status)

OSC = 1: Internal oscillator ON

Driver Output Mode Set(10H)

This instruction sets the display direction.

D/I	WRB	RDB	DB7	DB6	DB5	DB4	DB3	DB2	DB1	DB0
0	0	1	0	0	0	1	0	0	0	0
			0	0	DLN		0	SDIR	SWP	0

DLN: Display Line number selecting

DB5	DB4	Display Duty
0	0	1/128
0	1	1/144
1	0	1/160
1	1	1/176

SDIR: Segment direction

This bit is for controlling the direction of segment driver.

SDIR = 0 (Initial status)

SWP: Swap segment output SEG_{Ai} and SEG_{Gi}

This bit is for swapping the output of segment driver.

SWP = 0 (Initial status)

DC-DC Select (20H)

Selects DC-DC step-up of the common driver in normal and partial mode

D/I	WRB	RDB	DB7	DB6	DB5	DB4	DB3	DB2	DB1	DB0
0	0	1	0	0	1	0	0	0	0	0
			0	0	0	0	DC(2)		DC(1)	

DC(1) : 1' st DC-DC booster boosting step select for V1 generation in normal mode and partial mode 0.

DC(2) : 1' st DC-DC booster boosting step select for V1 generation in partial mode 1.

DC(2) : In partial mode 1		
DB3	DB2	DC-DC step up
0	0	X1.0
0	1	X1.5
1	0	X2.0
1	1	X2.0

DC(1) : In normal mode, partial mode 0		
DB1	DB0	DC-DC step up
0	0	X1.0
0	1	X1.5
1	0	X2.0
1	1	X2.0

DC-DC Select and power supply for V1 Op-Amp.

Even if VIN45 is connected to VOUT45 or VIN1, a setup by software must be able to be performed.
 Power supply for V1 Op.Amp. is decided by Hardware setting and Software setting.

The example of usage is shown below.

Figure28. Example : Hardware Setting : VIN45 connected to VOUT45
 Software Setting : Power supply for V1 Op.Amp. uses VIN1 (not VOUT45).

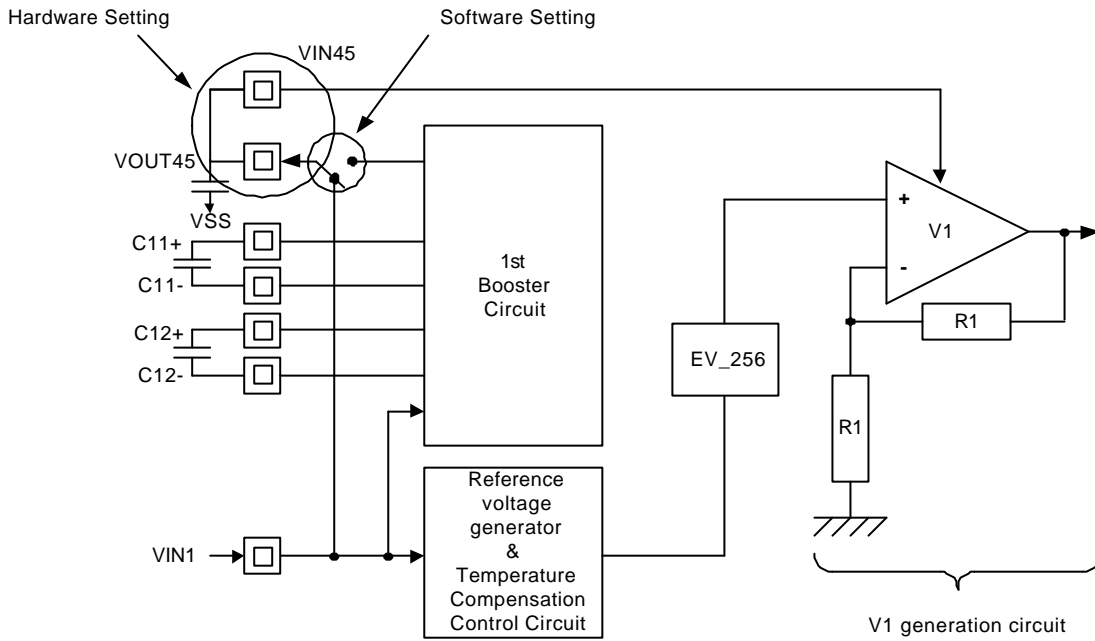

Hardware setting : VIN45 connected to (1) VIN1 (when 1' st boosting is not used)
 (2) VOUT45 (when 1' st boosting is used)

Software setting : DC-DC Select(20H) - DC(1), DC(2)

Set value "00" Power supply for V1 Op.Amp. uses VIN1 directly.

Set value "01" or "10" Power supply for V1 Op.Amp. uses VOUT45.

Bias Set (22H)

This instruction set up the value of bias in normal mode and in partial mode.

D/I	WRB	RDB	DB7	DB6	DB5	DB4	DB3	DB2	DB1	DB0
0	0	1	0	0	1	0	0	0	1	0
			0	0	Bias(2)		0	0	Bias(1)	

Bias(1): Bias value selecting in normal mode and partial mode0.

Bias(2): Bias value selecting in partial mode1.

Bias (2) : In partial mode 1			
DB5	DB4	Bias(2)	2' nd boosting step
0	0	1/4	x(-3)
0	1	1/5	x(-4)
1	0	1/6	x(-4)
1	1	1/7	x(-5)

Bias (1) : In normal mode, partial mode 0			
DB1	DB0	Bias(1)	2' nd boosting step
0	0	1/4	x(-3)
0	1	1/5	x(-4)
1	0	1/6	x(-4)
1	1	1/7	x(-5)

DCDC Clock Division Set(24H)

This instruction sets the internal booster clock frequency.

D/I	WRB	RDB	DB7	DB6	DB5	DB4	DB3	DB2	DB1	DB0
0	0	1	0	0	1	0	0	1	0	0
			0	0	DIV(2)		0	0	DIV(1)	

DIV(1) : DC-DC Charge Pump Division Ratio in Normal Mode Display and Partial Display Mode0

- DIV(1) = 10 (Initial status)

DIV(2) : Division Ratio in Partial Display Mode1

- DIV(2) = 10 (Initial status)

DB5	DB4	DIV(2)
0	0	fPCK = fOSC/4
0	1	fPCK = fOSC/8
1	0	fPCK = fOSC/16
1	1	fPCK = fOSC/32

DB1	DB0	DIV(1)
0	0	fPCK = fOSC/4
0	1	fPCK = fOSC/8
1	0	fPCK = fOSC/16
1	1	fPCK = fOSC/32

Note: fOSC = (ROUNDUP (Duty/3) + dummy) x 4 x 8 x frame frequency

DC/DC and AMP ON/OFF Set (26H)

This instruction set up the DC/DC and Op-amp in common start up setting.

D/I	WRB	RDB	DB7	DB6	DB5	DB4	DB3	DB2	DB1	DB0
0	0	1	0	0	1	0	0	1	1	0
			0	0	0	0	AMP	DCDC3	DCDC2	DCDC1

AMP: Built-in OP-AMP ON/OFF.

- AMP=0: OP-AMP OFF (Initial status)
- AMP=1: OP-AMP ON

DCDC1: Built-in 1' st Booster ON/OFF

- DCDC1= 0: 1' st Booster OFF (Initial status)
- DCDC1= 1: 1' st Booster ON

DCDC2: Built-in 2' nd Booster ON/OFF

- DCDC2= 0: 2' nd Booster OFF (Initial status)
- DCDC2= 1: 2' nd Booster ON

DCDC3: Built-in 3' rd Booster ON/OFF

- DCDC3= 0: 3' rd Booster OFF (Initial status)
- DCDC3= 1: 3' rd Booster ON

Temperature Compensation Set (28H)

This Instruction sets up the driving voltage slope for temperature compensation.

D/I	WRB	RDB	DB7	DB6	DB5	DB4	DB3	DB2	DB1	DB0
0	0	1	0	0	1	0	1	0	0	0
			0	0	0	0	0	0	TCS	

TCS: Temperature compensation slope set

- TCS = 00 : 0.00%/degC (Initial status)
- TCS = 01 : -0.05%/degC
- TCS = 10 : -0.10%/degC
- TCS = 11 : -0.15%/degC

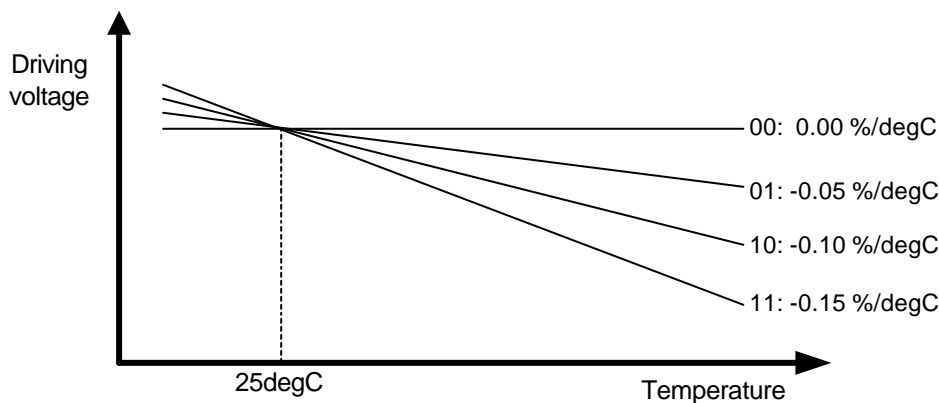

Temperature Compensation

If external temperature compensation is needed, circuit diagram is described as below.
 To use temperature compensation, two resistors and one thermistor are needed.

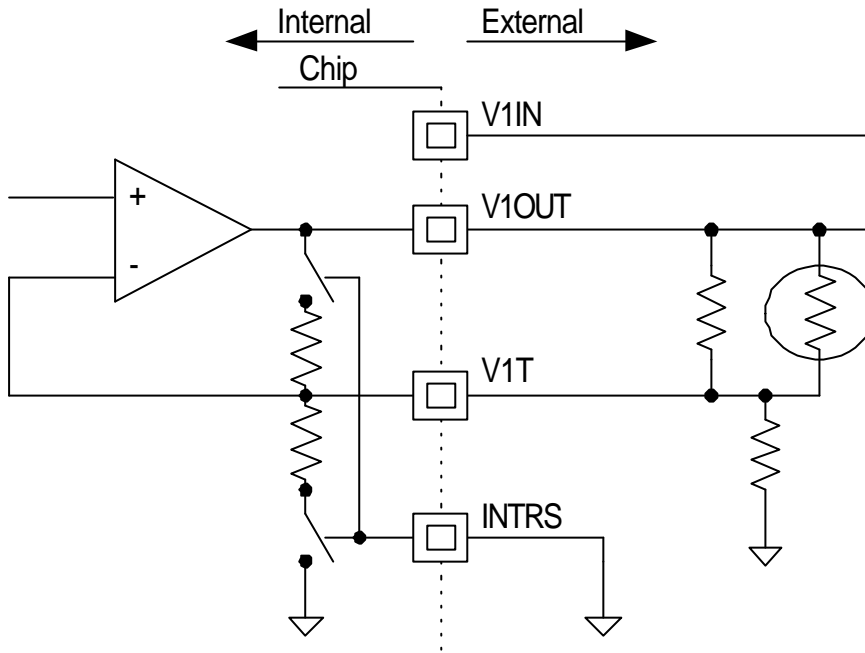

Contrast Control (1) (2AH)

This instruction updates the contrast control value in normal display mode and partial display mode 0.

D/I	WRB	RDB	DB7	DB6	DB5	DB4	DB3	DB2	DB1	DB0
0	0	1	0	0	1	0	1	0	1	0
Contrast control value (0 to 255)										

The relation between V1 voltage (typ.) and Contrast(1) set value (3bit step case)

Contrast(1) (HEX)	V1 [V]	Contrast(1) (HEX)	V1 [V]	Contrast(1) (HEX)	V1 [V]	Contrast(1) (HEX)	V1 [V]	Contrast(1) (HEX)	V1 [V]	Contrast(1) (HEX)	V1 [V]
00h	2.000	30h	2.376	60h	2.753	90h	3.129	C0h	3.506	F0h	3.882
08h	2.063	38h	2.439	68h	2.816	98h	3.192	C8h	3.569	F8h	3.945
10h	2.125	40h	2.502	70h	2.878	A0h	3.255	D0h	3.631	FFh	4.000
18h	2.188	48h	2.565	78h	2.941	A8h	3.318	D8h	3.694		
20h	2.251	50h	2.627	80h	3.004	B0h	3.380	E0h	3.757		
28h	2.314	58h	2.690	88h	3.067	B8h	3.443	E8h	3.820		

Contrast Control (2) (2BH)

This instruction updates the contrast control value in partial display mode 1.

D/I	WRB	RDB	DB7	DB6	DB5	DB4	DB3	DB2	DB1	DB0
0	0	1	0	0	1	0	1	0	1	1
Contrast control value (0 to 255)										

The relation between V1 voltage (typ.) and Contrast(2) set value (3 bit step case)

Contrast(2) (HEX)	V1 [V]	Contrast(2) (HEX)	V1 [V]	Contrast(2) (HEX)	V1 [V]	Contrast(2) (HEX)	V1 [V]	Contrast(2) (HEX)	V1 [V]	Contrast(2) (HEX)	V1 [V]
00h	2.000	30h	2.376	60h	2.753	90h	3.129	C0h	3.506	F0h	3.882
08h	2.063	38h	2.439	68h	2.816	98h	3.192	C8h	3.569	F8h	3.945
10h	2.125	40h	2.502	70h	2.878	A0h	3.255	D0h	3.631	FFh	4.000
18h	2.188	48h	2.565	78h	2.941	A8h	3.318	D8h	3.694		
20h	2.251	50h	2.627	80h	3.004	B0h	3.380	E0h	3.757		
28h	2.314	58h	2.690	88h	3.067	B8h	3.443	E8h	3.820		

Note :

S6B33B0A has a hardware protection for "2VR < 20V". It means the limitation of contrast value in each bias.

If 1/6 bias is set, max contrast value is limited to A9h, and if 1/7 bias is set, max contrast value is limited to 6Dh.

Standby Mode OFF (2CH)

This instruction releases the standby mode.

D/I	WRB	RDB	DB7	DB6	DB5	DB4	DB3	DB2	DB1	DB0
0	0	1	0	0	1	0	1	1	0	0

The internal statuses during standby off are as following:

- All common and segment output: VSS or V1
- Oscillator circuit: On (EXT = 0, OSC=1),OFF (others)
- Displaying clocks (FR, PM, CL): In operation

Function and Pin condition at standby OFF

Function/Pin	Condition
DC/DC booster(1' st,2' nd,3' rd)	ON(Operate)
COM outputs	+VR or VM or VSS or -VR
SEG outputs	V1 or VSS

Standby Mode ON (2DH)

This instruction enters the standby mode to reduce the power consumption to the static power consumption value (Initial status). The following instructions, standby off and display on, cause returning to the normal operation status.

D/I	WRB	RDB	DB7	DB6	DB5	DB4	DB3	DB2	DB1	DB0
0	0	1	0	0	1	0	1	1	0	1

The internal statuses during standby on are as following:

- All common and segment output: VSS
- Oscillator circuit: OFF
- Displaying clocks (FR, PM, CL) are held.

Function and Pin condition at standby ON

Function/Pin	Condition
DC/DC booster(1' st,2' nd,3' rd)	OFF
SEG and COM outputs	VSS

LCD driving power output condition at Standby ON.

level	Condition
+VR	VSS
V1	VSS
VM	VSS
-VR	VSS

DDRAM Burst Mode OFF(2EH) /ON(2FH)

D/I	WRB	RDB	DB7	DB6	DB5	DB4	DB3	DB2	DB1	DB0
0	0	1	0	0	1	0	1	1	1	BM

BM: Internal DDRAM Burst Mode Interface Off/On Control
 - 0 : Burst Mode Interface Off(Initial Status)
 - 1 : Burst Mode Interface On

When BM=0, If MPU[0] is 0 then internal DDRAM I/F bpw(bits per word) is 8 bits.
 Else MPU[0] is 1 then internal DDRAM I/F bpw(bits per word) is 16bits.
 When BM=1, Regardless of MPU[0] bit, Internal DDRAM I/F bpw(bits per word) is 32 bits.

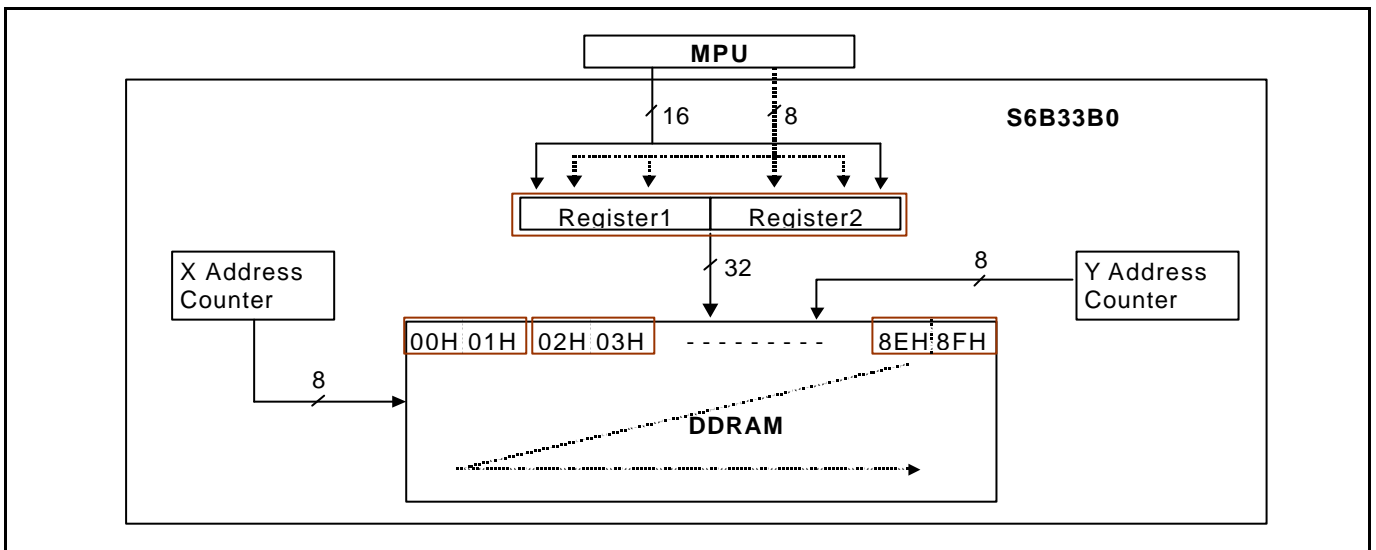

Figure 23. Burst mode writing to DDRAM

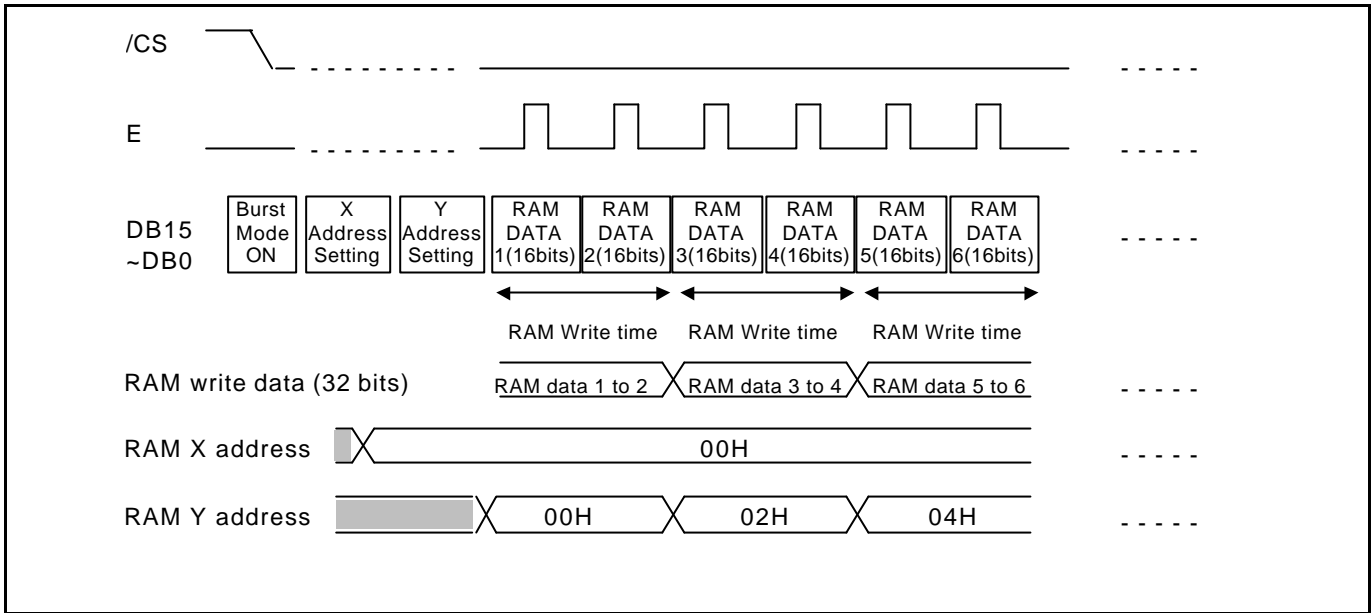

Figure 24. Example of the Burst mode writing to DDRAM (68-mode 16-bit parallel interface)

When DDRAM burst mode is used, note the following.

Notes:

1. Data is written to DDRAM each two words. If only one word data is written to DDRAM, the data will not be written.
So, the number of word data must be even. It means that Y start address must be even and Y end address must be odd.
2. X address count mode can't be used.
3. Burst mode and normal mode write operation cannot be executed at the same time.
4. In the read data mode and serial interface mode, the burst mode can't be used.
5. In the 256 color mode with 16-bit data bus mode and 4,096 color mode with 8-bit data bus mode, The address is counted as burst mode enable. So these modes are influenced by above notes.

Addressing Mode Set (30H)

D/I	WRB	RDB	DB7	DB6	DB5	DB4	DB3	DB2	DB1	DB0
0	0	1	0	0	1	1	0	0	0	0
			0	GSM		DSG	SGF	SGP		SGM

GSM: Gray Scale Mode

- 00 : 65,536 color mode(Initial status)
- 01 : 4,096 color mode* (refer to "Data Format Select(60H/61H)")
- 10 : 256 color mode*
- 11 : 256 color mode*

* In the 256 color mode with 16-bit data bus mode and 4,096 color mode with 8-bit data format B, the address is counted as burst mode enable. So, In this case, refer to notes of burst mode at page 39.

DSG : Duty Adjust Setting

- 0 : Dummy subgroup is one subgroup (Initial status)
- 1 : Dummy subgroup is none

SGF : Sub Group Frame Inversion mode setting

- 0: SG Frame inversion OFF (Initial status)
- 1: SG Frame inversion ON

SGM : Sub Group inversion mode setting

- 0: SG inversion OFF (Initial status)
- 1: SG inversion ON

SGP : Sub Group Phase mode setting

- 00 : Same phase in all pixels
- 01 : Different phase by 1pixel-unit
- 10 : Different phase by 2pixel-unit
- 11 : Different phase by 4pixel-unit

Row Vector Mode Set (32H)

Setting ROW function.

D/I	WRB	RDB	DB7	DB6	DB5	DB4	DB3	DB2	DB1	DB0
0	0	1	0	0	1	1	0	0	1	0
			0	0	0	0	INC			VEC

INC: Row Vector Increment Mode. This Parameter set up Row vector increment period

DB3	DB2	DB1	Row Vector Increment Period
0	0	0	Every subgroup
0	0	1	Every 2subgroup
0	1	0	Every 4subgroup
0	1	1	Every 8subgroup
1	0	0	Every 16subgroup
1	0	1	Every 16subgroup
1	1	0	Every 16subgroup
1	1	1	Every subframe

VEC: ROW Vector Sequence Mode

- 0: R1->R2->R3->R4 -> R1..... (initial status)
- 1: R1->R3->R2->R4 -> R1.....



256 Color Mode Palettes

At 256-color mode, the instruction and parameter below set each Gray Scale level of the Red/Green/Blue. Gray scale level is determined by GS data.

Red Palette (38H)

D/I	WRB	RDB	DB7	DB6	DB5	DB4	DB3	DB2	DB1	DB0		
0	0	1	0	0	1	1	1	0	0	0		
			0	0	0	GS data "000" to RAM data						
			0	0	0	GS data "001" to RAM data						
			0	0	0	GS data "010" to RAM data						
			0	0	0	GS data "011" to RAM data						
			0	0	0	GS data "100" to RAM data						
			0	0	0	GS data "101" to RAM data						
			0	0	0	GS data "110" to RAM data						
			0	0	0	GS data "111" to RAM data						

Green Palette (3AH)

D/I	WRB	RDB	DB7	DB6	DB5	DB4	DB3	DB2	DB1	DB0	
0	0	1	0	0	1	1	1	0	1	0	
			0	0	GS data "000" to RAM data						
			0	0	GS data "001" to RAM data						
			0	0	GS data "010" to RAM data						
			0	0	GS data "011" to RAM data						
			0	0	GS data "100" to RAM data						
			0	0	GS data "101" to RAM data						
			0	0	GS data "110" to RAM data						
			0	0	GS data "111" to RAM data						

Blue Palette (3CH)

D/I	WRB	RDB	DB7	DB6	DB5	DB4	DB3	DB2	DB1	DB0		
0	0	1	0	0	1	1	1	1	0	0		
			0	0	0	GS data "00" to RAM data						
			0	0	0	GS data "01" to RAM data						
			0	0	0	GS data "10" to RAM data						
			0	0	0	GS data "11" to RAM data						

Initial value for each Palette

Gray Scale Data	Initial Gray Scale Level		
	Red	Green	Blue
000	0	0	0
001	8	16	12
010	12	24	20
011	16	32	31
100	20	40	-
101	24	48	-
110	28	56	-
111	31	63	-

The relationship between Gray Scale level and RAM data for Red/Blue

RAM Data					GS Level	RAM Data					GS Level
DB4	DB3	DB2	DB1	DB0		DB4	DB3	DB2	DB1	DB0	
0	0	0	0	0	0	1	0	0	0	0	16
0	0	0	0	1	1	1	0	0	0	1	17
0	0	0	1	0	2	1	0	0	1	0	18
0	0	0	1	1	3	1	0	0	1	1	19
0	0	1	0	0	4	1	0	1	0	0	20
0	0	1	0	1	5	1	0	1	0	1	21
0	0	1	1	0	6	1	0	1	1	0	22
0	0	1	1	1	7	1	0	1	1	1	23
0	1	0	0	0	8	1	1	0	0	0	24
0	1	0	0	1	9	1	1	0	0	1	25
0	1	0	1	0	10	1	1	0	1	0	26
0	1	0	1	1	11	1	1	0	1	1	27
0	1	1	0	0	12	1	1	1	0	0	28
0	1	1	0	1	13	1	1	1	0	1	29
0	1	1	1	0	14	1	1	1	1	0	30
0	1	1	1	1	15	1	1	1	1	1	31

The relationship between Gray Scale level and Gray Scale data for Green

GS Data						GS Level	GS Data						GS Level
DB5	DB4	DB3	DB2	DB1	DB0		DB5	DB4	DB3	DB2	DB1	DB0	
0	0	0	0	0	0	0	1	0	0	0	0	0	32
0	0	0	0	0	1	1	1	0	0	0	0	1	33
0	0	0	0	1	0	2	1	0	0	0	1	0	34
0	0	0	0	1	1	3	1	0	0	0	1	1	35
0	0	0	1	0	0	4	1	0	0	1	0	0	36
0	0	0	1	0	1	5	1	0	0	1	0	1	37
0	0	0	1	1	0	6	1	0	0	1	1	0	38
0	0	0	1	1	1	7	1	0	0	1	1	1	39
0	0	1	0	0	0	8	1	0	1	0	0	0	40
0	0	1	0	0	1	9	1	0	1	0	0	1	41
0	0	1	0	1	0	10	1	0	1	0	1	0	42
0	0	1	0	1	1	11	1	0	1	0	1	1	43
0	0	1	1	0	0	12	1	0	1	1	0	0	44
0	0	1	1	0	1	13	1	0	1	1	0	1	45
0	0	1	1	1	0	14	1	0	1	1	1	0	46
0	0	1	1	1	1	15	1	0	1	1	1	1	47
0	1	0	0	0	0	16	1	1	0	0	0	0	48
0	1	0	0	0	1	17	1	1	0	0	0	1	49
0	1	0	0	1	0	18	1	1	0	0	1	0	50
0	1	0	0	1	1	19	1	1	0	0	1	1	51
0	1	0	1	0	0	20	1	1	0	1	0	0	52
0	1	0	1	0	1	21	1	1	0	1	0	1	53
0	1	0	1	1	0	22	1	1	0	1	1	0	54
0	1	0	1	1	1	23	1	1	0	1	1	1	55
0	1	1	0	0	0	24	1	1	1	0	0	0	56
0	1	1	0	0	1	25	1	1	1	0	0	1	57
0	1	1	0	1	0	26	1	1	1	0	1	0	58
0	1	1	0	1	1	27	1	1	1	0	1	1	59
0	1	1	1	0	0	28	1	1	1	1	0	0	60
0	1	1	1	0	1	29	1	1	1	1	0	1	61
0	1	1	1	1	0	30	1	1	1	1	1	0	62
0	1	1	1	1	1	31	1	1	1	1	1	1	63

N-block inversion Set (34H)

This instruction set up N block inversion for AC driving.

D/I	WRB	RDB	DB7	DB6	DB5	DB4	DB3	DB2	DB1	DB0
0	0	1	0	0	1	1	0	1	0	0
			FIM	FIP	0	N-block inversion				

FIM: Forcing Inversion Mode

FIM = 0: Forcing Inversion OFF (Initial status)

FIM = 1: Forcing Inversion ON

FIP: Forcing Inversion Period

FIP = 0: Forcing Inversion Period is one frame

FIP = 1: Forcing Inversion Period is two frames

N-block Inversion : This parameter indicates the basic period of polarity inversion.

The whole period of polarity inversion is decided by FIM, FIP and this parameter.

DB7	DB6	DB5	DB4 – DB0	Polarity Inversion Period
x	X	x	0	every frame
0	X	x	1	every 1 block
:	:	:	:	:
0	X	x	31	every 31 blocks
1	0	x	1	every 1 block and every frame
:	:	:	:	:
1	0	x	31	every 31 blocks and every frame
1	1	x	1	every 1 block and every 2 frames
:	:	:	:	:
1	1	x	31	every 31 blocks and every 2 frames

Entry Mode Set (40H)

Setting internal function mode.

D/I	WRB	RDB	DB7	DB6	DB5	DB4	DB3	DB2	DB1	DB0
0	0	1	0	1	0	0	0	0	0	0
			0	0	0	0	HL	MDI	X/Y	RMW

HL: When GSM is 10 or 11 (256 color mode),

Exchange higher and lower byte in 16-bit data bus mode only for "Display Data Write/Read"

HL = 0: Not exchanged status (Initial status)

HL = 1: Exchanged status

MDI: Memory data inversion setting for low power consumption.

MDI = 0: Memory data inversion OFF (Initial status)

MDI = 1: Memory data inversion ON

<MDI=0>

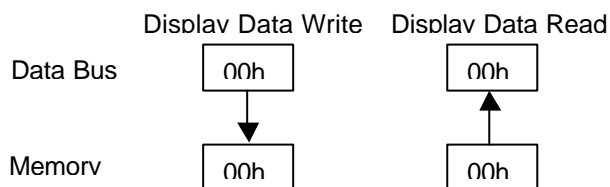

<MDI=1>

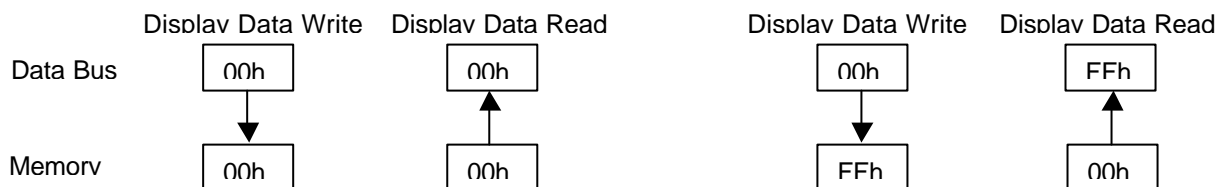

X/Y: Memory address counter mode setting

X/Y = 0: Y address counter mode (Initial status)

X/Y = 1: X address counter mode

RMW: Read modify write mode ON/OFF select

RMW = 0: Read modify write OFF (Initial status)

RMW = 1: Read modify write ON. When this mode is on, X(Y) address of on-chip display RAM is not increment in reading display data but in writing display data.

X Address Area Set (42H)

This instruction and parameter set up the X address areas of the on-chip display data RAM.

D/I	WRB	RDB	DB7	DB6	DB5	DB4	DB3	DB2	DB1	DB0		
0	0	1	0	1	0	0	0	0	1	0		
			X start address set (Initial Status = 00H)									
			X end address set (Initial Status = AFH)									

The current X address of the on-chip display data RAM is the X start address by setting this instruction. In X address count mode (X/Y = "H"), the X address is increased from X start address to X end address. When X address is equal to the X end address, the Y address is increased by 1 and the X address returns to X start address. The X start and X end addresses must be set as a pair and X start address must be less than X end address.

Y Address Area Set (43H)

This instruction and parameter set up the Y address areas of the on-chip display data RAM.

D/I	WRB	RDB	DB7	DB6	DB5	DB4	DB3	DB2	DB1	DB0
0	0	1	0	1	0	0	0	0	1	1
Y start address set (Initial Status = 00H)										
Y end address set (Initial Status = 8FH)										

The current Y address of the on-chip display data RAM is the Y start address by setting this instruction. In Y address count mode (X/Y = "L"), the Y address is increased from Y start address to Y end address. When Y address is equal to the Y end address, the X address is increased by 1 and the Y address returns to Y start address. The Y start and Y end address must be set as a pair and Y start address must be less than Y end address.

RAM Skip Area Set (45H)

This instruction and parameter set up the X address areas of the on-chip display data RAM.

D/I	WRB	RDB	DB7	DB6	DB5	DB4	DB3	DB2	DB1	DB0
0	0	1	0	1	0	0	0	1	0	1
			0	0	0	0	0	0	RSK	

RSK : RAM Skip function ON/OFF set

- RSK = 00 : No Skip
- RSK = 01 : Y address 44h-4Bh skip
- RSK = 10 : Y address 40h-4Fh skip
- RSK = 11 : Y address 3Ch-53h skip

RAM Skip Area Set

RAM Skip Area Set can skip a part of RAM Y-address area. After setting RAM skip area, Y-address count skip this area and count. In other words, Y address after skip area is changed into Y address which added a part for skip area.

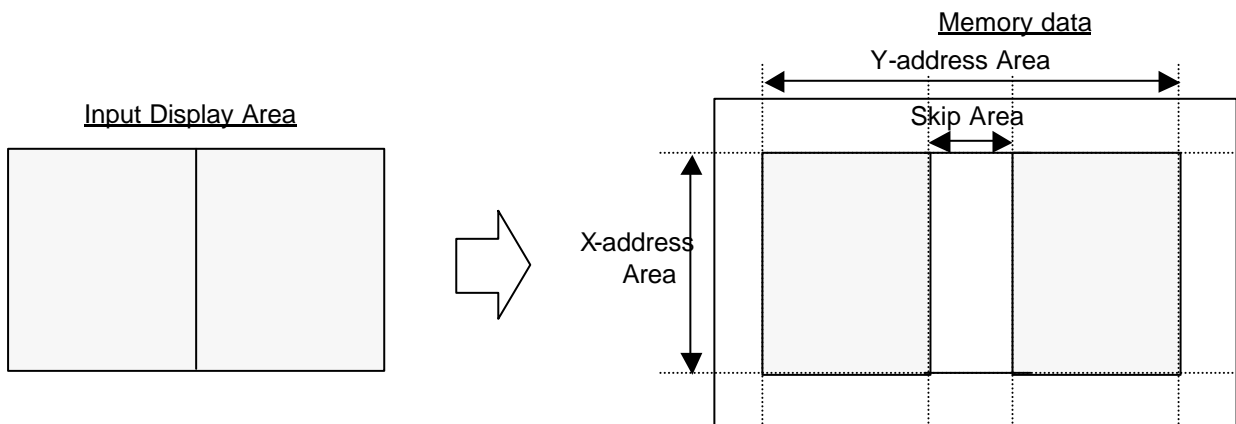

Display OFF (50H)

Turn the display OFF(Initial status).

When display is off, all segment and common output are VSS level.

D/I	WRB	RDB	DB7	DB6	DB5	DB4	DB3	DB2	DB1	DB0
0	0	1	0	1	0	1	0	0	0	0

Function and Pin condition at Display OFF

Function/Pin	Condition
DC/DC booster(1' st,2' nd,3' rd)	ON(Operate)
SEG and COM outputs	VSS

Display ON (51H)

Turns the display ON.

In case of being standby mode, this instruction does not work. This instruction is executed after standby mode off.

D/I	WRB	RDB	DB7	DB6	DB5	DB4	DB3	DB2	DB1	DB0
0	0	1	0	1	0	1	0	0	0	1

Function and Pin condition at Display ON

Function/Pin	Condition
DC/DC booster(1' st,2' nd,3' rd)	ON(Operate)
COM outputs	+VR or VM or -VR
SEG outputs	V1 or VSS

Specified Display Pattern Set (53H)

This instruction sets the specified display pattern.

D/I	WRB	RDB	DB7	DB6	DB5	DB4	DB3	DB2	DB1	DB0
0	0	1	0	1	0	1	0	0	1	1
			0	0	0	0	0	0	0	SDP

SDP : Specified Display Pattern set

- SDP = 00 : Normal display
- SDP = 01 : Reverse display : Display data reversing mode setting without the contents of the display RAM
- SDP = 10 : Whole display pattern becomes OFF regardless of the RAM data.
- SDP = 11 : Whole display pattern becomes ON regardless of the RAM data.

Partial Display Mode Set (55H)

D/I	WRB	RDB	DB7	DB6	DB5	DB4	DB3	DB2	DB1	DB0
0	0	1	0	1	0	1	0	1	0	1
			0	0	0	0	0	0	0	PDM

PT: Partial Display ON/OFF

- PT = 0: Partial display OFF = Normal mode (Initial status)
- PT = 1: Partial display ON

PDM: Partial Display mode set

- PDM = 0: Partial mode 0 : Duty ratio is same as Normal display mode(initial status)
- PDM = 1: Partial mode 1 : Duty ratio is changed from Normal display mode
(DSG = 0 : 69 line fixed(including 1 dummy subgroup),
DSG = 1 : 66 line fixed(no dummy subgroup))

Applied parameter in PDM0 and PDM1 are summarized as below

PDM	Contrast	Duty	Bias	DC-DC Select	OSC	PCK
0	Contrast control(1)	Normal	Bias(1)	DC(1)	OSC1-OSC2	DIV(1)
1	Contrast control(2)	1/69	Bias(2)	DC(2)	OSC3-OSC4	DIV(2)

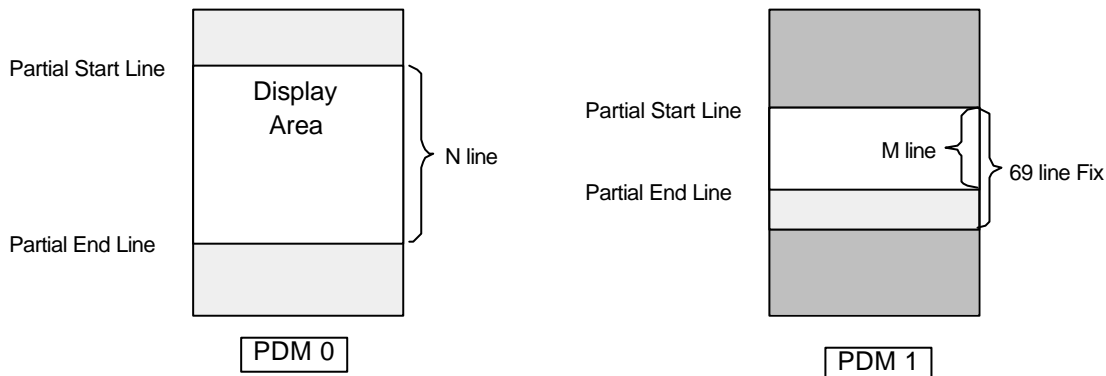

- No display Area : No COM Scanning field (COM = Vm fixed)
- Except Partial Display Area : COM Timing is existing, but COM = Vm fixed
- Partial Display Area : Real display field

Operation in Partial Display Mode 0 (PDM=0)

- On scanning except partial display area
 - SEG output select V0 or V1 level depend on "FR" value. Refer to Page51.
 - All of COM output is fixed VM level.
- On scanning partial display area
 - It is equal to be in normal mode

Operation in Partial Display Mode 1 (PDM=1)

- Display area is from partial start line to partial end line.
(COM driver output is fixed VM except display area, only max69 line output COM signal.)
- On scanning except partial display area
 - SEG output select V0 or V1 level depend on "FR" value. Refer to Page51.
 - All of COM output is fixed VM level.
- On scanning partial display area
 - It is equal to be in normal mode



Partial Display Mode0

Item	Partial Display Area	Out of Partial Display Area
Duty	Same as normal display mode	
Bias	Same as normal display mode (Bias(1) setting)	
Contrast	Same as normal display mode (Contrast(1) setting)	
Oscillator	Same as normal display mode (OSC1 – OSC2)	
SEG Output level	Same as normal mode (V1,V0)	Depends on Internal "FR" signal See page 51
COM Output level	Same as normal mode (+VR,VM,-VR)	VM fixed

In case of COM 6 to COM11 Partial display

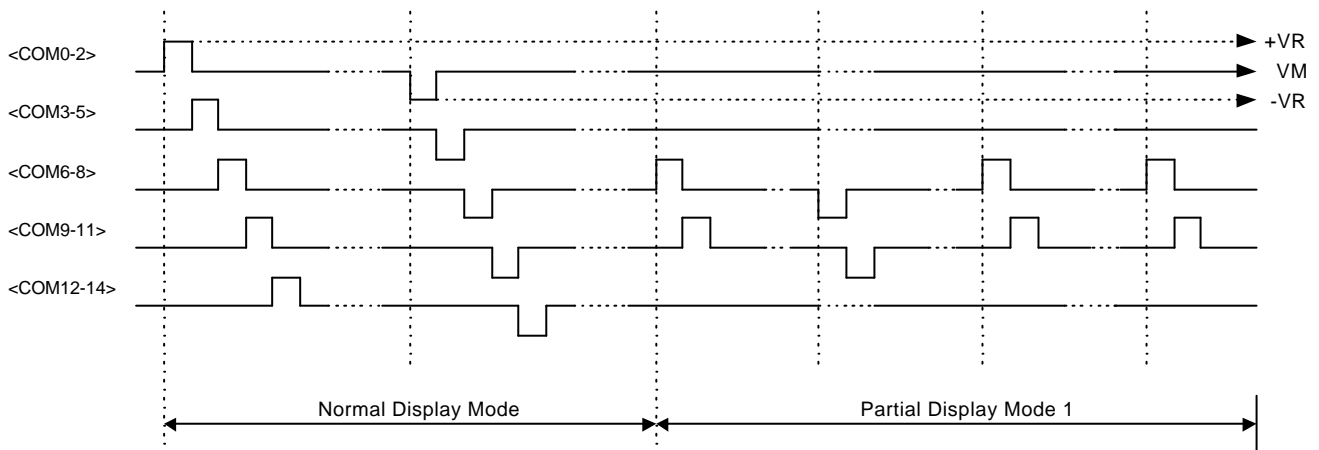
**Partial display mode1**

Item	Partial Display Area	Out of Partial Display Area	Out of Display Area
Duty	1/69duty		
Bias	Bias(2) setting		
Contrast	Contrast(2) setting		
Oscillator	(OSC3 – OSC4) setting value		
SEG Output level	Same as normal mode (V1,V0)	Depends on "FR" signal See page 51	-
COM Output level	Same as normal mode (+VR, VM, -VR)	VM fixed	VM fixed

Partial Display Start Line Set (56H), Partial Display End Line Set(57H)

These 2 instructions set the partial display area and it is possible to display a part.

Partial Display Start Line Set (56H)

D/I	WRB	RDB	DB7	DB6	DB5	DB4	DB3	DB2	DB1	DB0
0	0	1	0	1	0	1	0	1	1	0
Partial start line										

Partial Display End Line Set (57H)

D/I	WRB	RDB	DB7	DB6	DB5	DB4	DB3	DB2	DB1	DB0
0	0	1	0	1	0	1	0	1	1	1
Partial end line										

COM 0	line 0
COM 1	line 1
COM 2	line 2
COM 3	line 3
	:
	:
	:
COM 172	line 172
COM 173	line 173
COM 174	line 174
COM 175	line 175

Parameter set appoints display line number. At PDM 0, Parameter Size is able to be in a number of Display lines. But that is not able to be over max 69 line at PDM 1. Partial end line must set bigger number than Partial start line.

Example of Segment Voltage in non-display area

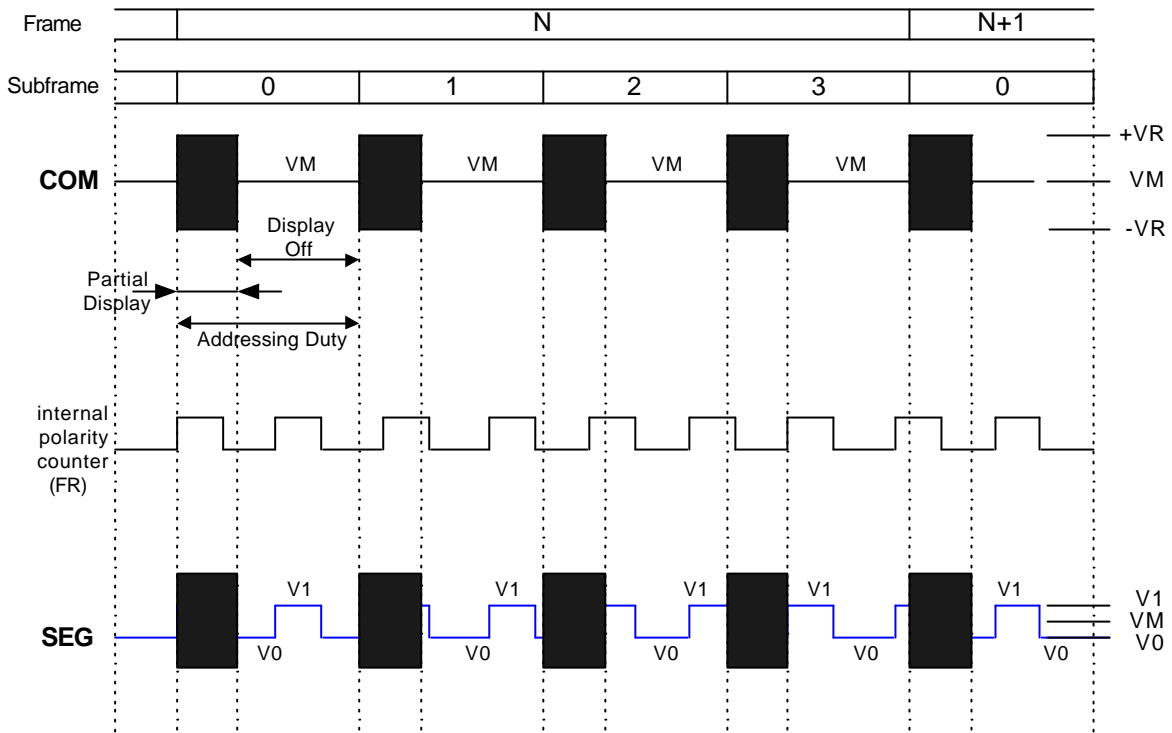

Area scroll Set (59H)

This instruction sets up area scroll field (start line, end line, Lower fixed line number), and it is possible to make screen to display as partial scroll field.

D/I	WRB	RDB	DB7	DB6	DB5	DB4	DB3	DB2	DB1	DB0	
0	0	1	0	1	0	1	1	0	0	1	
			0	0	0	0	0	0	SCM		
			Scroll area start line								
			Scroll area end line								
Lower fixed number											

SCM: Scroll mode setting

DB1	DB0	Mode
0	0	Entire display(Initial status)
0	1	Upper scroll display
1	0	Lower scroll display
1	1	Center scroll display

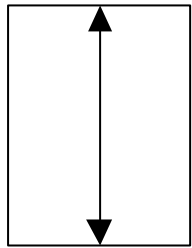

Entire Display

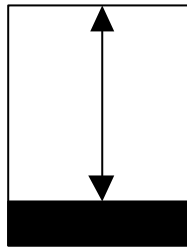

Upper Display

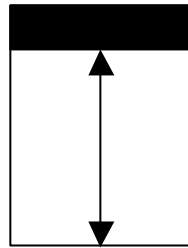

Lower Display

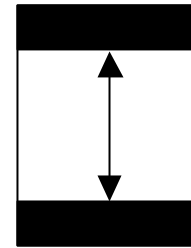

Center Display

Scroll Start Line Set (5AH)

This instruction and parameter set up scroll start line. On this instruction, scroll start line becomes the first of area scroll field. Scroll operation is occurred every issue of this instruction.

D/I	WRB	RDB	DB7	DB6	DB5	DB4	DB3	DB2	DB1	DB0
0	0	1	0	1	0	1	1	0	1	0
Scroll start line										

<Example>

- DLN : 2' b11 (1/176 duty)
- SCM : 2' b11 (Center display mode)
- Scroll area start line : 6
- Scroll area end line : 166
- Lower fixed number : 9
- Scroll start line : 40

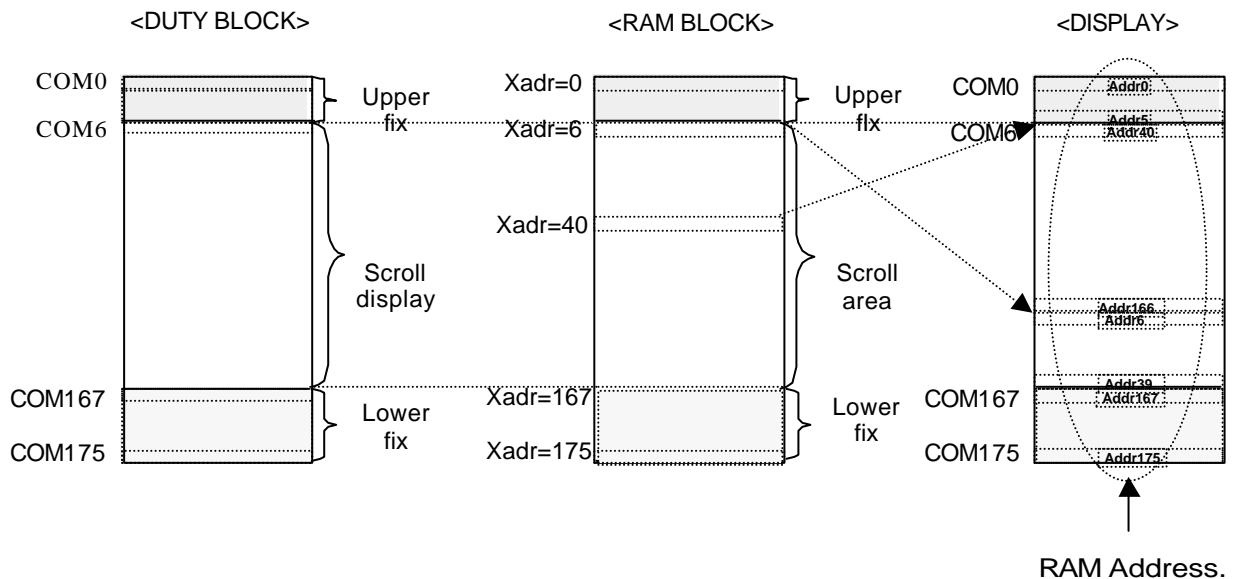

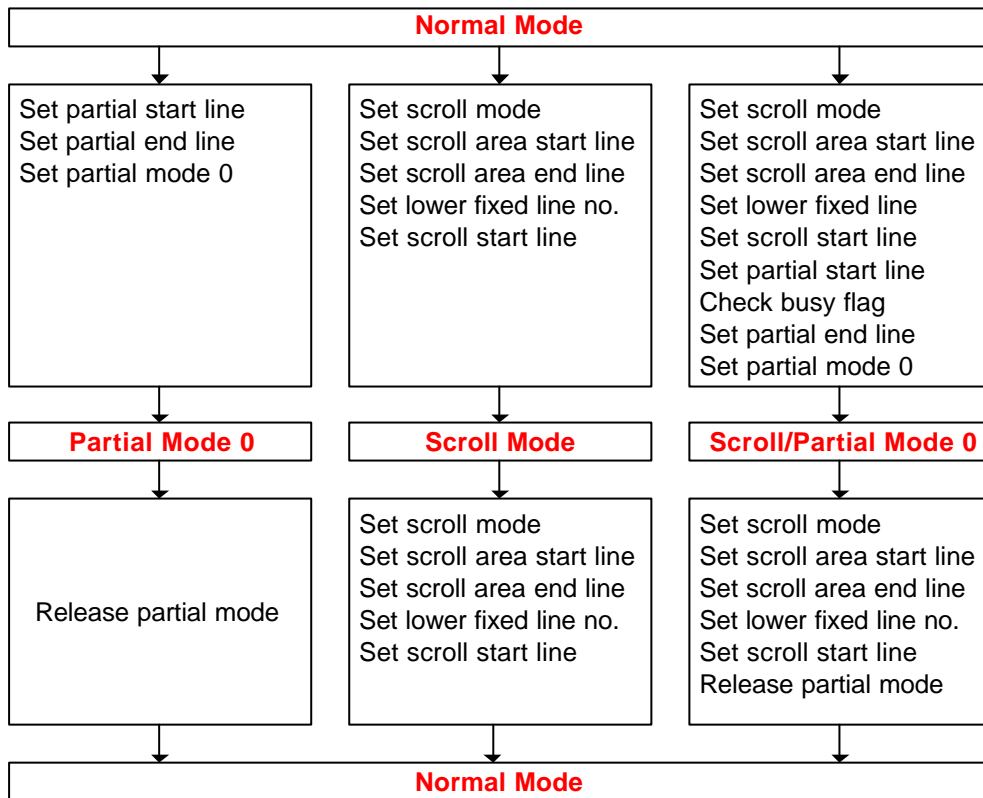

Data Format Select (60H/61H)

D/I	WRB	RDB	DB7	DB6	DB5	DB4	DB3	DB2	DB1	DB0
0	0	1	0	1	1	0	0	0	0	DFS

DFS: 4,096 Color Mode Data Format Select

- 0 : 4,096 Color Data Format A (Initial Status)

8 bit mode :

DB[7:0] : XXXRRRR (1' st write)

DB[7:0] : GGGBBBB (2' nd write)

16 bit mode :

DB[15:0] : XXXRRRRGGGGBBBB (12 bit)

- 1 : 4,096 Color Data Format B

8 bit mode :

DB[7:0] : RRRRGGGG (1' st write)

DB[7:0] : BBBRRRR (2' nd write)

DB[7:0] : GGGBBBB (3' rd write)

16 bit mode :

DB[15:0] : RRRRGGGGBBBBXXXX (12 bit)

Display Data Write/Read

D/I	WRB	RDB	DB15 ~ DB8	DB7	DB6	DB5	DB4	DB3	DB2	DB1	DB0
1	0	1	Display RAM write in data								
1	1	0	Display RAM read out data								

GSM = 00(65,536 Color Mode)

(1) 16bit access mode

	15	14	13	12	11	10	9	8	7	6	5	4	3	2	1	0
1' st cycle	R4	R3	R2	R1	R0	G5	G4	G3	G2	G1	G0	B4	B3	B2	B1	B0
2' nd cycle	R4	R3	R2	R1	R0	G5	G4	G3	G2	G1	G0	B4	B3	B2	B1	B0

(2) 8bit access mode

	7	6	5	4	3	2	1	0
1' st cycle	R4	R3	R2	R1	R0	G5	G4	G3
2' nd cycle	G2	G1	G0	B4	B3	B2	B1	B0
3' rd cycle	R4	R3	R2	R1	R0	G5	G4	G3
4' th cycle	G2	G1	G0	B4	B3	B2	B1	B0

GSM = 01(4,096 Color Mode)

(1) 16bit access mode

	15	14	13	12	11	10	9	8	7	6	5	4	3	2	1	0
1' st cycle	X	X	X	X	R3	R2	R1	R0	G3	G2	G1	G0	B3	B2	B1	B0
2' nd cycle	X	X	X	X	R3	R2	R1	R0	G3	G2	G1	G0	B3	B2	B1	B0

(2) 8bit access mode

	7	6	5	4	3	2	1	0
1' st cycle	X	X	X	X	R3	R2	R1	R0
2' nd cycle	G3	G2	G1	G0	B3	B2	B1	B0
3' rd cycle	X	X	X	X	R3	R2	R1	R0
4' th cycle	G3	G2	G1	G0	B3	B2	B1	B0

GSM = 10 or 11 (256 Color Mode)

(1) 16bit access mode

	15	14	13	12	11	10	9	8	7	6	5	4	3	2	1	0
1' st cycle	R2	R1	R0	G2	G1	G0	B1	B0	R2	R1	R0	G2	G1	G0	B1	B0
2' nd cycle	R2	R1	R0	G2	G1	G0	B1	B0	R2	R1	R0	G2	G1	G0	B1	B0

(2) 8bit access mode

	7	6	5	4	3	2	1	0
1' st cycle	R2	R1	R0	G2	G1	G0	B1	B0
2' nd cycle	R2	R1	R0	G2	G1	G0	B1	B0
3' rd cycle	R2	R1	R0	G2	G1	G0	B1	B0
4' th cycle	R2	R1	R0	G2	G1	G0	B1	B0



Status Read

D/I	WRB	RDB	DB7	DB6	DB5	DB4	DB3	DB2	DB1	DB0
0	1	0	BSY	X/Y	0	PDM	PT	STB	REV	DP

This instruction indicates the internal status of the S6B33B0A.

DP: (0 : Display OFF Status, 1 : Display ON Status)

REV: (0 : Display Image Non-Reversing, 1 : Display Image Reversing)

STB: (0 : Standby Mode OFF Status, 1 : Standby Mode ON Status)

PT: (0 : Partial Display Mode OFF Status, 1 : Partial Display Mode ON Status)

PDM: (0 : Partial Display Mode 0, 1 : Partial Display Mode 1)

X/Y: (0 : Y-address Count Mode, 1 : X-address Count Mode)

BSY: (0 : No Busy, 1 : Busy)

Set Display Data Length (FCH)

This Instruction is only used in 3-pin SPI MPU interface mode(PS=" L" , MPU[1]=" L"). It consists of two continuous commands, the first byte control the data direction(write mode only) and inform the LCD driver the second and third bytes will be number of data bytes will be write. When DI is not used, the Display Data Length instruction is used to indicate that a specified number of display data bytes are to be transmitted. The next byte after the display data string is handled as command data.

D/I	WRB	RDB	DB7	DB6	DB5	DB4	DB3	DB2	DB1	DB0
0	0	1	1	1	1	1	1	1	0	0
			Number of display data upper 8bits (DDL_H)							
			Number of display data lower 8bits (DDL_L)							

Test Mode1 (FFH)

This Instruction is for testing IC. User is not permitted to access. if access, have to reset.

D/I	WRB	RDB	DB7	DB6	DB5	DB4	DB3	DB2	DB1	DB0
0	0	1	1	1	1	1	1	1	1	1

Test Mode2 (FEH)

This Instruction is for testing IC. User is not permitted to access. if access, have to reset.

D/I	WRB	RDB	DB7	DB6	DB5	DB4	DB3	DB2	DB1	DB0
0	0	1	1	1	1	1	1	1	1	0

Test Mode3 (FDH)

This Instruction is for testing IC. User is not permitted to access. if access, have to reset.

D/I	WRB	RDB	DB7	DB6	DB5	DB4	DB3	DB2	DB1	DB0
0	0	1	1	1	1	1	1	1	0	1

Test Mode4 (FBH)

This Instruction is for testing IC. User is not permitted to access. if access, have to reset.

D/I	WRB	RDB	DB7	DB6	DB5	DB4	DB3	DB2	DB1	DB0
0	0	1	1	1	1	1	1	0	1	1

Test Mode5 (FAH)

This Instruction is for testing IC. User is not permitted to access. if access, have to reset.

D/I	WRB	RDB	DB7	DB6	DB5	DB4	DB3	DB2	DB1	DB0
0	0	1	1	1	1	1	1	0	1	0

Test Mode6 (F9H)

This Instruction is for testing IC. User is not permitted to access. if access, have to reset.

D/I	WRB	RDB	DB7	DB6	DB5	DB4	DB3	DB2	DB1	DB0
0	0	1	1	1	1	1	1	0	0	1

INSTRUCTION PARAMETER

Table 16. Instruction Parameter

Instruction	Hex	Para.	DB7	DB6	DB5	DB4	DB3	DB2	DB1	DB0
Oscillation Mode Set	02H	1	0	0	0	0	0	0	EXT	OSC
			*	*	*	*	*	*	0	0
Driver Output Mode Set	10H	1	0	0	DLN		0	SDIR	SWP	0
			*	*	0	0	*	0	0	0
DC-DC Set	20H	1	0	0	0	0	DC(2)		DC(1)	
			0	0	0	0	0	0	0	0
Bias Set	22H	1	0	0	Bias(2)		0	0	Bias(1)	
			0	*	0	0	*	*	0	0
DCDC Clock Division Set	24H	1	0	0	DIV(2)		0	0	DIV(1)	
			*	*	1	0	*	*	1	0
DCDC and AMP ON/OFF Set	26H	1	0	0	0	0	AMP	DCDC3	DCDC2	DCDC1
			*	*	*	*	0	0	0	0
Temperature Compensation Set	28H	1	0	0	0	0	0	0	TCS	
			*	*	*	*	*	*	0	0
Contrast Control (1)	2AH	1	Contrast control value in normal and partial display mode0(0 to 255)							
			0	0	0	0	0	0	0	0
Contrast Control(2)	2BH	1	Contrast control value in partial display mode 1(0 to 255)							
			0	0	0	0	0	0	0	0
Addressing Mode Set	30H	1	0	GSM		DSG	SGF	SGP		SGM
			*	*	0	0	0	0	0	0
ROW Vector Mode Set	32H	1	0	0	0	0	INC			VEC
			*	*	*	*	0	0	0	0
N-line Inversion Set	34H	1	FIM	FIP	0	N-block Inversion				
			0	0	*	0	0	0	0	0
Entry Mode Set	40H	1	0	0	0	0	HL	MDI	X/Y	RMW
			*	*	*	*	*	0	0	0
X-address Area Set	42H	2	X Start address set							
			0	0	0	0	0	0	0	0
			X end address set							
Y-address Area Set	43H	2	Y start address set							
			0	0	0	0	0	0	0	0
			Y end address set							
RAM Skip Area Set	42H	1	1	0	0	0	1	1	1	1
			0	0	0	0	0	0	RSK	
Set Display Data Length	FCH	2	*	*	*	*	*	*	0	0
			Number of display data DDL_H							
Specified Display Pattern Set	53H	1	Number of display data DDL_L							
			0	0	0	0	0	0	SDP	
Partial Display Mode Set	55H	1	*	*	*	*	*	*	0	0
			0	0	0	0	0	0	PDM	PT
Partial Display Start Line Set	56H	1	*	*	*	*	*	*	0	0
			Partial start line							
Partial Display End Line Set	57H	1	0	0	0	0	0	0	0	0
			Partial end line							
			0	0	0	0	0	0	0	0

Table 16. Instruction Parameter (Continued)

Instruction	Hex	Para.	DB7	DB6	DB5	DB4	DB3	DB2	DB1	DB0	
Area Scroll Mode Set	59H	4	0	0	0	0	0	0	SCM		
			*	*	*	*	*	*	0	0	
			Scroll area start line								
			0	0	0	0	0	0	0	0	0
			Scroll area end line								
			1	0	1	0	1	1	1	1	1
			Lower Fixed number								
			0	0	0	0	0	0	0		
Scroll Start Line Set	5AH	1	Scroll start line								
			0	0	0	0	0	0	0	0	

Reset Operation

When RSTB becomes "L", following procedure is occurred.

- X start address: 0, X end address: 176
- Y start address: 0, Y end address: 143
- Display OFF
- Read Modify Write Mode OFF
- Function Mode Set
 - MDI = 0: Memory Data Inversion OFF
 - OSC = 0: Oscillator OFF
 - EXT = 0: Internal Oscillator Mode
 - REV = 0: Reversing mode OFF
 - X/Y = 0: Y-address Count Mode
 - Standby Mode ON
- DCDC Clock Division Set
 - DIV(1) = 10: fPCK = fOSC/16x
 - DIV(2) = 10: fPCK = fOSC/16x
- Duty Set
 - Display Duty = 00H: 1/128 duty
- DC-DC Select
 - DC(1) = 0: X1 step-up
 - DC(2) = 0: X1 step-up
- Bias Set
 - Bias(1) = 0H: 1/4 bias
 - Bias(2) = 0H: 1/4 bias
- DC/DC and AMP ON/OFF Set
 - AMP =0: Built-in OP-AMP OFF
 - DCDC1 =0: Built-in 1' st booster OFF
 - DCDC2 =0: Built-in 2' nd booster OFF
 - DCDC3 =0: Built-in 3' rd booster OFF
- N-block inversion
 - FIM =0: Forcing Inversion OFF
 - FIP =0: Forcing Inversion Period in one frame
 - N-block inversion = 00H: frame inversion
- Partial Display Mode
 - PT = 0: Partial Display Mode OFF
 - PDM = 0: Partial Mode 0
- Partial Display Area Set
 - Partial start line = 00H
 - Partial end line = 00H
- Area Scroll Set
 - Mode = 00H : Entire Display Scroll Mode
 - Area Start Line: 00H
 - Area End Line: AFH
 - Lower Fixed Line Number: 00H
- Scroll Start Line Set
 - Scroll Start Line: 00H
- Addressing Mode Set
 - GSM=00: 65,536 Color Mode
- DSG = 0: Mode 0
- SGF = 0: SG Frame Inversion OFF
- SGM = 0: SG Reverse Mode OFF
 - SGP=00: Same phase in all pixel
- Row Vector Mode Set
 - INC =000: Increment every subgroup
 - VEC=0: R1->R2->R3->R4->R1->...

POWER ON/OFF SEQUENCE

Power ON Sequence

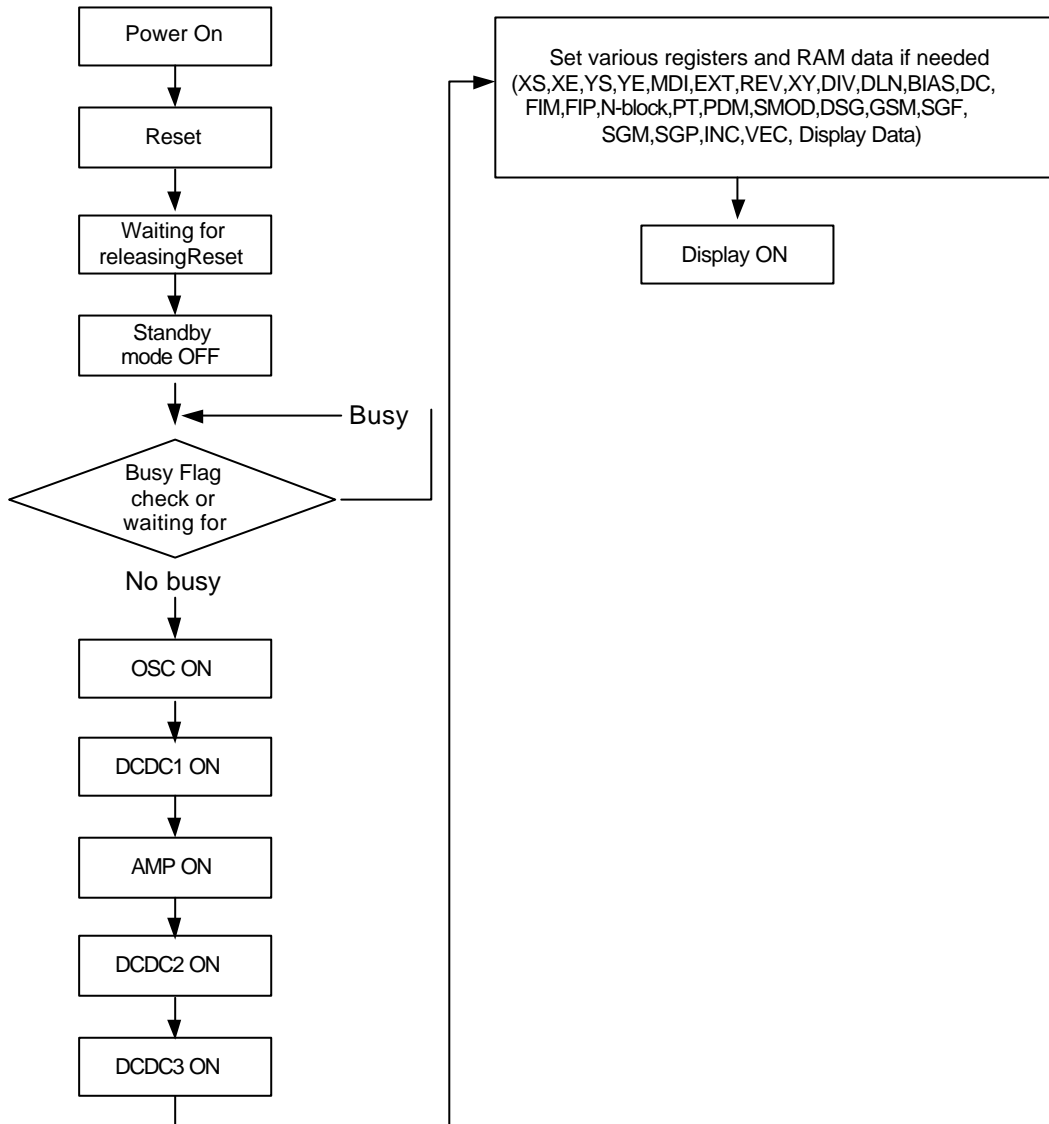

Power OFF Sequence

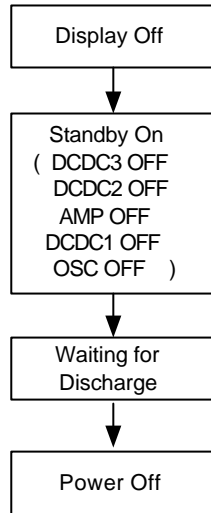

SPECIFICATIONS

ABSOLUTE MAXIMUM RATINGS

Item	Symbol	Rating	Unit
Supply Voltage range	VDD3	-0.3 to +4.0	V
LCD Supply Voltage range	VCC – VEE	22	V
Input Voltage range	V _{in}	- 0.3 to VDD +0.3	V
Operating Temperature range	TOPR	-30 to +70	°C
Storage Temperature range	TSTR	-55 to +150	°C

OPERATING VOLTAGE

Item	Symbol	Min.	Typ.	Max.	Unit
Supply Voltage (1)	VDD3	1.8	-	3.3	V
Supply Voltage (2)	2V _r	4.0	-	20	V
Supply Voltage (3)	V _{IN}	2.4	3.0	3.6	V

DC CHARACTERISTICS (1)

(V_{SS} = 0V, V_{DD3} = 1.8 to 3.3V, T_a = -30 to 70 °C)

Item	Symbol	Condition	Min	Typ	Max	Unit	Remarks	
Operating voltage	VDD3		1.8		3.3	V	VDD3	
Operating voltage	VIN1		2.4	-	3.6	V	VIN1, VIN1A	
Operating voltage	VIN2		2.4	-	7.2	V		
Operating voltage	VIN45		2.4	-	7.2	V	VOUT45	
Operating voltage	DC2IN	1/4 Bias	1.5	-	3.0	V	DC2OUT	
		1/5 Bias	1.33	-	2.67			
		1/6 Bias	1.67	-	3.33			
		1/7 Bias	1.5	-	3.0			
Operating voltage	2Vr	2Vr = [(+VR) - (-VR)]	4.0	-	20	V	+VR, -VR	
Driving voltage input range	VM	External power supply mode	1.0		2.0	V	VMOUT	
	VCC		5.0		12.0	V	VRP	
	VEE		-3.0		-8.0	V	VRN	
Input voltage	High	V _{IH}	0.8VDD	-	VDD	V		
	Low	V _{IL}	VSS	-	0.2VDD			
Output voltage	High	V _{OH}	I _{OH} = 0.5mA	0.8VDD	-	VDD	V	
	Low	V _{OL}	I _{OL} = 0.5mA	VSS	-	0.2VDD		
Input leakage current	I _{IL}	V _{IN} = VDD or VSS	-1.0	-	+1.0	μA		
Output leakage current	I _{OZ}	V _{IN} = VDD or VSS	-3.0	-	+3.0	μA		
Oscillator Frequency Tolerance	Normal or Partial 0	FOSC1	R1=80kOhm (fFR=100Hz target), DSG=0, 176 display lines	172.8	192.0	211.2	kHz	OSC1 OSC2
	Partial 1	FOSC2	R1=300kOhm (fFR=70Hz target), 69 display lines	46.36	51.52	56.68	kHz	OSC3 OSC4
Oscillator Frequency Range	Normal or Partial 0	FOSC1	(*1)	84.48		288	kHz	OSC1 OSC2
	Partial 1	FOSC2	(*2)	29.44		88.32	kHz	OSC3 OSC4
Driving voltage input range	V1		2.0	-	4.0	V		
	VM		1.0	-	2.0			
Regulator output range	REG_OUT	REG_ENB = "L"	1.8	-	2.2	V		

(*1) Minimum oscillator frequency range is defined at fFR=60Hz and display line number=128
Maximum oscillator frequency range is defined at fFR=150Hz and display line number=176

(*2) Minimum oscillator frequency range is defined at fFR=40Hz and display line number=69

Maximum oscillator frequency range is defined at fFR=120Hz and display line number=69

DC CHARACTERISTICS (2)

Item	Symbol	Condition	Min	Typ	Max	Unit	Remarks
Driver output resistance	SEG	R _{ON-Seg}		1.5	3.0	kΩ	SEg _n
	COM	R _{ON-Com}		1.0	1.5	kΩ	COM _n
Current consumption	Normal Mode	IDD		650	750	μA	VDD3 + VIN1
	Partial1 Mode			200	250	μA	

* : "IDD" is determined from lowest power consumption for dc-dc converter.

DC CHARACTERISTICS (3)

(V_{SS} = 0V, V_{DD3} = 1.8 to 3.3V, V_{IN1}=2.4 to 3.6V, T_a = -30 to 70 °C)

Item	Symbol	Condition	Min	Typ	Max	Unit	Remarks
Voltage shift range(*1)	$\Delta (+VR)$	I _{source} = 80uA	-	-	150	mV	+VR
	$\Delta (V1)$	I _{source} = 250uA	-	-	20	mV	V1
	$\Delta (VM)$	I _{source,sink} = 250uA	-	-	20	mV	VM
	$\Delta (-VR)$	I _{sink} = 80uA	-	-	150	mV	-VR

(*1) Voltage shift means output voltage deference between output current = I_{load} and no-load.
Refer to the following figure. (in case of source current mode)

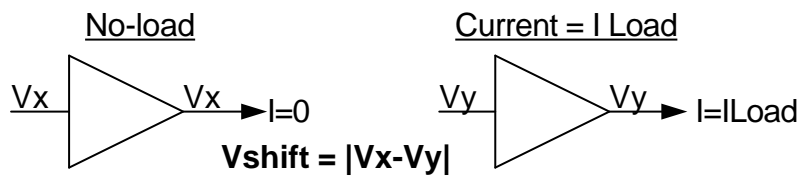

Item	Symbol	Condition	Min	Typ	Max	Unit	Remarks
Tolerance of Bias ratio	$\Delta (+VR)_0$ $\Delta (-VR)_0(*1)$	No load	-100	-	+100	mV	+VR -VR

(*1) Tolerance of bias ratio definition
 $\Delta (+VR)_0 = ((+VR) - VM) - VM / \text{Bias}$
 $\Delta (-VR)_0 = (VM - (-VR)) - VM / \text{Bias}$

DC CHARACTERISTICS (4)

(V_{SS} = 0V, V_{DD3} = 1.8 to 3.3V, V_{IN1}=2.4 to 3.6V, T_a = -30 to 70 °C)

Item	Symbol	Condition	Min	Typ	Max	Unit	Remarks	
Temperature compensation	ΔV_t	V _{DD3} =V _{IN1} =V ₁ =3.0V, -20 to 70 °C	-0.02	-	+0.02	%/°C	V1	
Tolerance of Contrast step of V1	ΔV_{step}		3.13	6.27	9.41	mV	V1	
Voltage range	ΔV_1 ΔV_M	Contrast set = FFh	V1	3.95	4.00	4.05	V	V1
			V _M	1.95	2.00	2.05	V	V _M
		Contrast set = 00h	V1	1.95	2.00	2.05	V	V1
			V _M	0.95	1.00	1.05	V	V _M

Item		Condition		Max	Unit	Ref
		Load current	Voltage range			
Offset Voltage	$ +VR-VM - VM-(-VR) $	I Load = +100uA (+VR) I Load = -100uA (-VR)	+VR=5.0~12.0 V V1=2.0~4.0V VM=1.0~2.0V -VR=-3.0~-8.0 V	100	mV	Fig.1
	$ V1-VM - VM-V0 $	A I Load = +100uA (V1, VM) B I Load = +100uA (+VR) I Load = -100uA (-VR)		50	mV	Fig.2

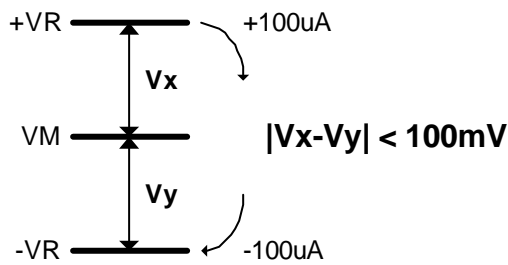

Fig. 1: Offset voltage definition (+VR,VM,-VR)

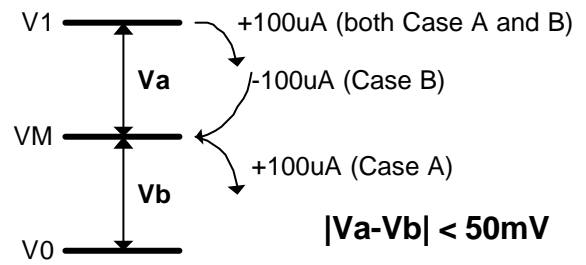

Fig. 2: Offset voltage definition (V1,VM,V0)

DC CHARACTERISTICS (5)

(V_{SS} = 0V, V_{DD3} = 1.8 to 3.3V, VIN1=2.4 to 3.6V, Ta = -30 to 70 °C)

Item		Range	
		Min	Max
Voltage Level	V1OUT	2.0 V	4.0 V (DC(1) and DC(2) = X2) (*1)
	VMOUT	1.0 V	2.0 V (DC(1) and DC(2) = X2) (*2)
	DC2OUT	1.33V (1/5 Bias, V1OUT = 2V)	3.33V (DC(1) and DC(2) = X2) (*3) (1/6 Bias, V1OUT = 4V)

(*1) This definition is shown as below

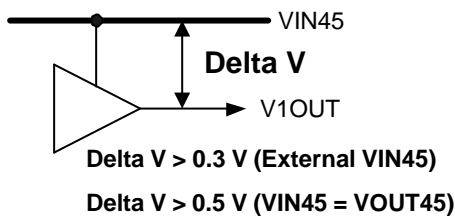

If V1OUT input voltage is set over VIN45, V1OUT output voltage must be clipped near VIN45. In this case, V1OUT output level must not be unstable. Refer to Fig.1

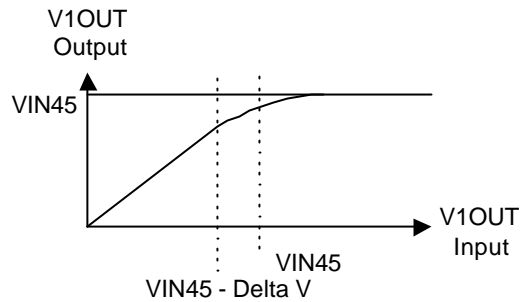

(*2) This definition is shown as below

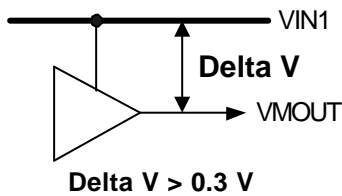

If VMOUT input voltage is set over VIN1, VMOUT output voltage must be clipped near VIN1. In this case, VMOUT output level must not be unstable. Refer to Fig.2

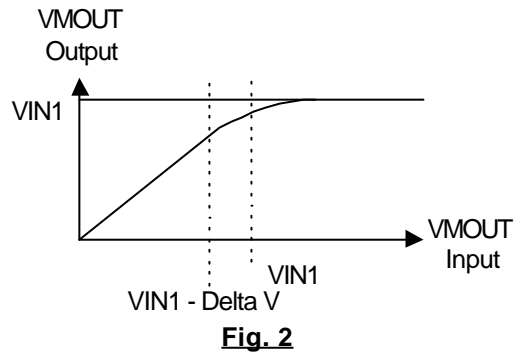

(*3) This definition is shown as below

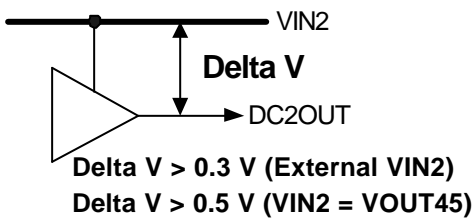

If DC2OUT input voltage is set over VIN2, DC2OUT output voltage must be clipped near VIN2. In this case, VMOUT output level must not be unstable. Refer to Fig.3

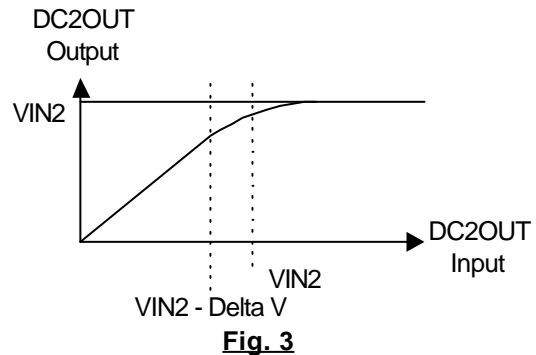

AC CHARACTERISTICS

Read / Write Characteristics (8080-series MPU)

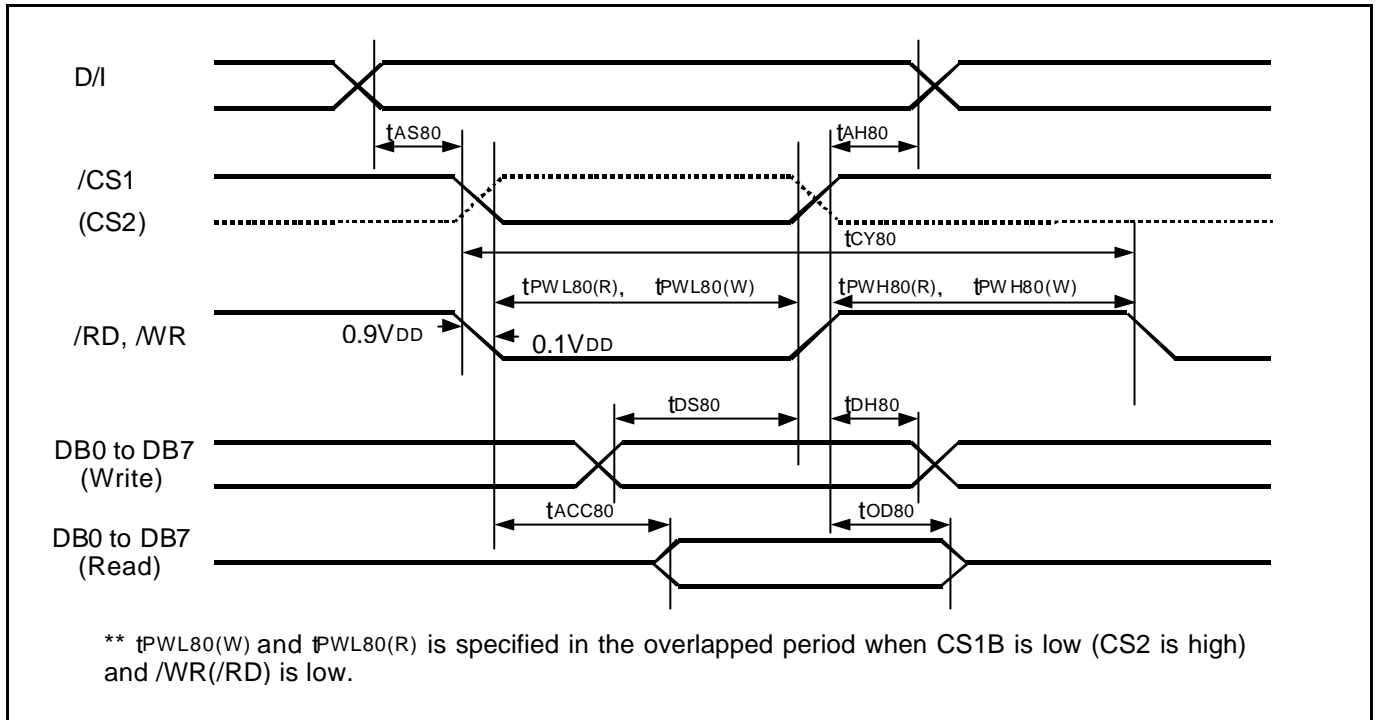

Figure 25. Parallel Interface (8080-series MPU) Timing Diagram

Table 17. AC Characteristics (8080-series Parallel Mode)

(VDD3 = 1.8 to 3.3V, Ta = -30 to +70°C)

Item	Signal	Symbol	Condition	Min.		Max. (3.3V/1.8V)	Unit
				3.3V	1.8V		
Address setup time Address hold time	D/I	t_{AS80} t_{AH80}		0 0	0 0	- -	ns
System cycle time		t_{CY80}		150	360	-	ns
Pulse width low for write Pulse width High for write	WRB (WRB)	t_{PWLW} t_{PWHW}		50 30	100 75	- -	ns
Pulse width low for read Pulse width high for read	RDB (RDB)	$t_{PWL R}$ $t_{PWH R}$		50 30	100 75	- -	ns
Data setup time Data hold time	DB0 to DB15	t_{DS80} t_{DH80}		5 8	10 14	- -	ns
Read access time Output disable time		t_{ACC80} t_{OD80}	CL = 100 pF	-	60 / 120		ns
				t_{EWHR}			

NOTE: *1. The input signal rise time and fall time (tr, tf) is specified at 10 ns or less.
 (tr + tf) < (tCY80 - tPWLW - tPWHW) for write, (tr + tf) < (tCY80 - tPWL R - tPWH R) for read

Read / Write Characteristics (6800-series Microprocessor)

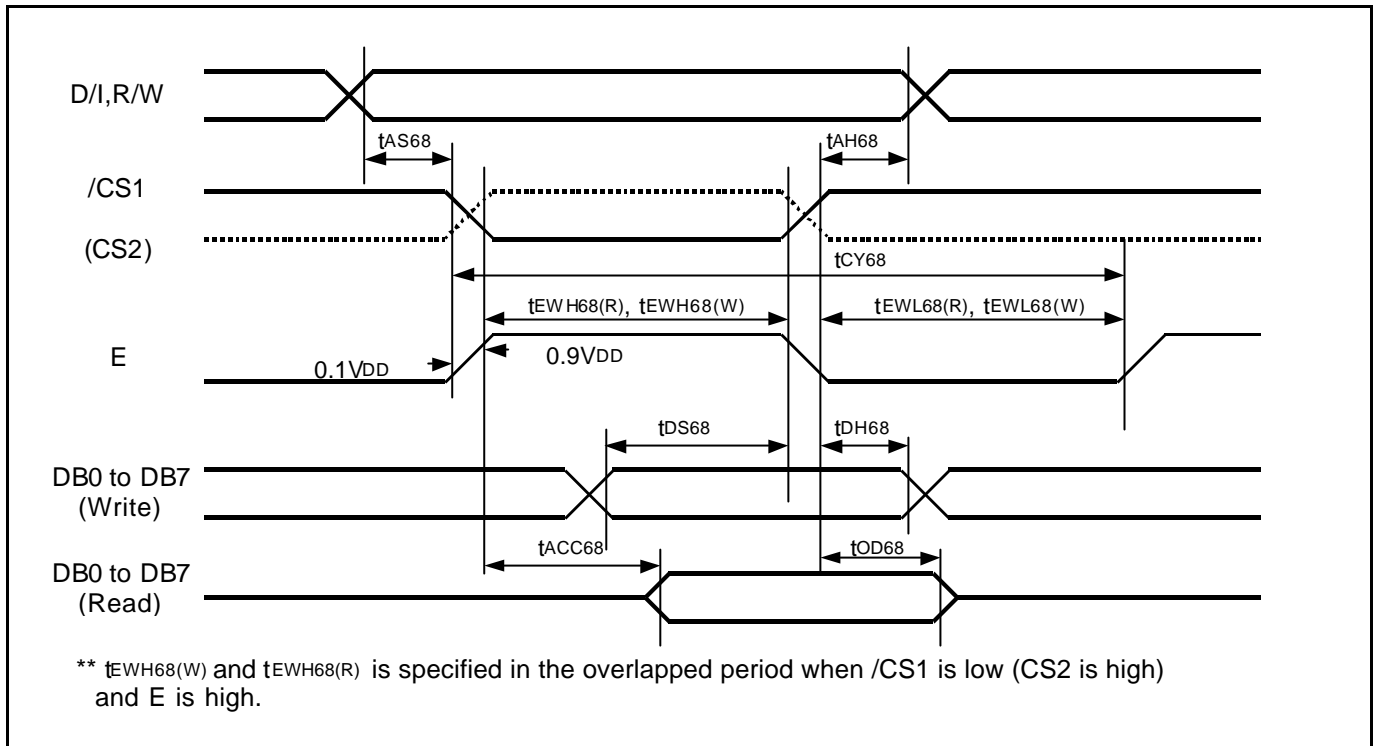

Figure 26. Parallel Interface (6800-series MPU) Timing Diagram

Table 18. AC Characteristics (6800-series Parallel Mode)

($V_{DD3} = 1.8$ to $3.3V$, $T_a = -30$ to $+70^\circ C$)

Item	Signal	Symbol	Condition	Min.		Max. (3.3V/1.8V)	Unit
				3.3V	1.8V		
Address setup time	D/I	t_{AS68}		0	0	-	ns
Address hold time	R/W	t_{AH68}		0	0	-	
System cycle time		t_{CY68}		150	360	-	ns
Enable width high for write	RDB	t_{EWHW}		50	100	-	ns
Enable width low for write	(E)	t_{EWLW}		30	75	-	
Enable width high for read	RDB	t_{EWHR}		50	100	-	ns
Enable width low for read	(E)	t_{EWLR}		30	75	-	
Data setup time	DB0 to DB15	t_{DS68}		5	10	-	ns
Data hold time		t_{DH68}		8	14	-	
Read access time	DB0 to DB15	t_{ACC68}	$C_L = 100$ pF	-		60 / 120	ns
Output disable time		t_{OD68}		t_{EWLR}			

NOTE: *1. The input signal rise time and fall time (t_r , t_f) is specified at 10 ns or less.
 $(t_r + t_f) < (t_{CY68} - t_{EWHW} - t_{EWLW})$ for write, $(t_r + t_f) < (t_{CY68} - t_{EWHR} - t_{EWLR})$ for read

Serial Data Interface Timing

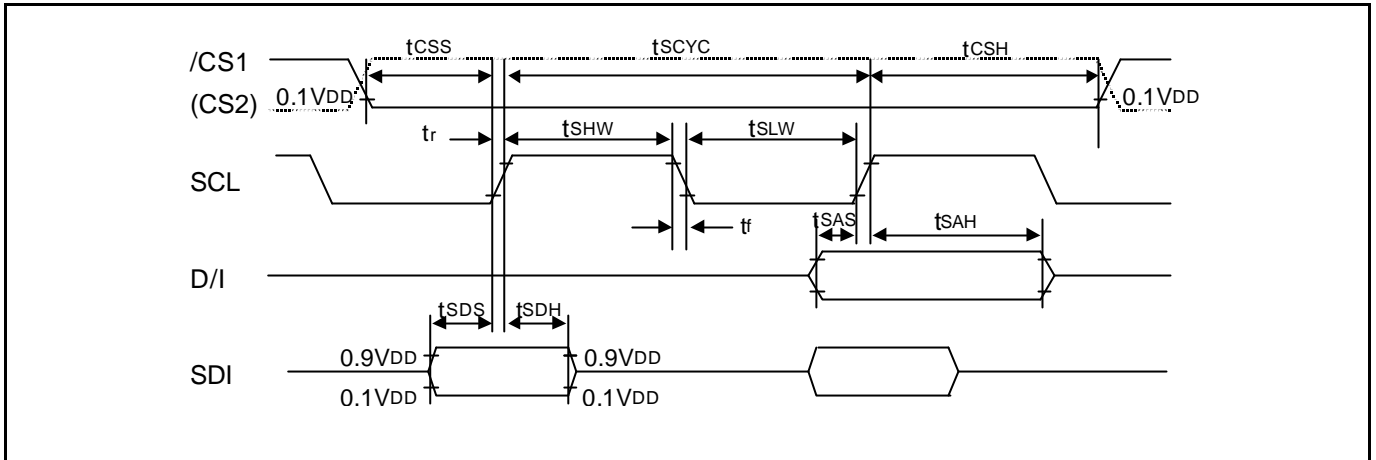

Table 19. Serial Data Interface Timing

(VDD3 = 1.8 to 3.3V, Ta = -30 to +70°C)

Item	Signal	Symbol	Condition	Min.	Max.	Unit
SCL Cycle Time	SCL	t _{csc}		50	-	ns
SCL High Pulse Width	SCL	t _{shw}		20	-	ns
SCL Low Pulse Width	SCL	t _{slw}		20	-	ns
SDI Setup time	SDI	t _{sdS}		20	-	ns
SDI Hold time	SDI	t _{sdH}		20	-	ns
D/I Setup time	D/I	t _{sas}		20	-	ns
D/I Hold time	D/I	t _{saH}		20	-	ns
Chip Select Setup time	CS1B(CS2)	t _{css}		20	-	ns
Chip Select Hold time	CS1B(CS2)	t _{chs}		20	-	ns

Reset Input Timing

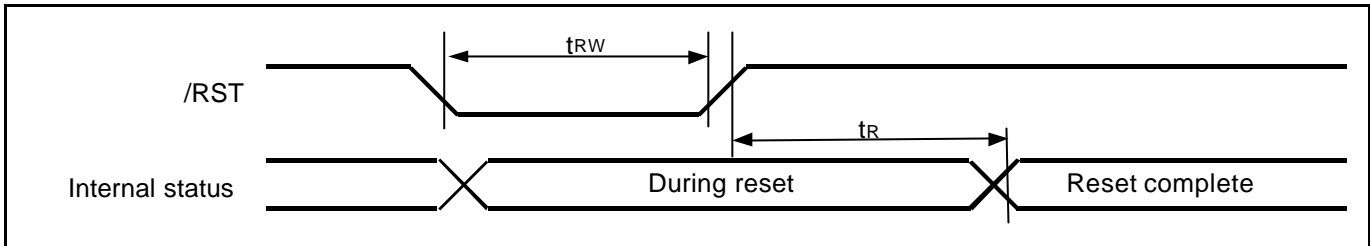

Figure 27. Reset Input Timing Diagram

Table 20. AC Characteristics (Reset mode)

(V_{DD3} = 1.8 to 3.3V, T_a = -30 to +70°C)

Item	Signal	Symbol	Condition	Min.	Max.	Unit
Reset low pulse width	RSTB	t_{RW}		1000	-	ns
Reset time	-	t_R		-	1000	ns

SYSTEM APPLICATION DIAGRAM

Internal Power Mode

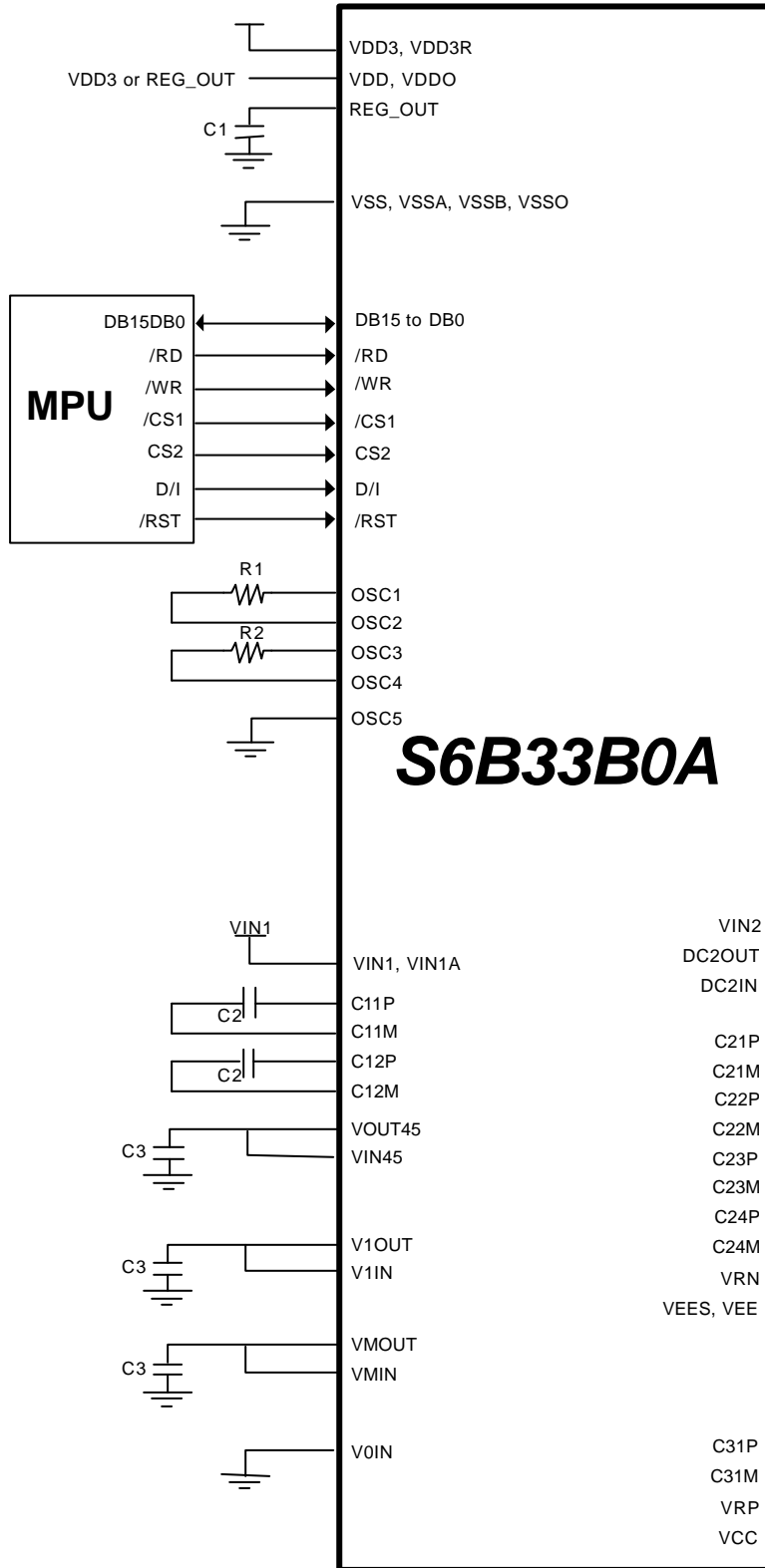

External Components

Name	Device
R1,R2	Resistors
C1,C2,C3	Capacitors
D1	Schottky barrier diode

Values of external Capacitors and D1

Item	Capacitance
C1	1.0 to 4.7 μ F
C2	1.0 to 2.2 μ F
C3	1.0 to 2.2 μ F
D1	Vforward = Max. 0.3V at 1mA Vreverse = Min. 15V

Maximum rating voltage of capacitors

Item	Maximum rating voltage
REG_OUT to VSS	3V
VOUT45 to VSS	11V
C11P to C11M	6V
C12P to C12M	6V
VMOUT to VSS	3V
DC2OUT to VSS	5V
V1OUT to VSS	6V
C21P to C21M	5V
C22P to C22M	10V
C23P to C23M	13V
C24P to C24M	13V
VSS to VRN	13V
C31P to C31M	17V
VRP to VSS	18V



External Power Mode

