

BUS-CONTROLLED AUDIO MATRIX

- 5 STEREO INPUTS
- 4 STEREO OUPUTS
- GAIN CONTROL 0/2/4/6dB/MUTE FOR EACH OUTPUT
- CASCADABLE (2 different addresses)
- SERIAL BUS CONTROLLED
- VERY LOW NOISE
- VERY LOW DISTORSION

DESCRIPTION

The TEA6420 switches 5 stereo audio inputs on 4 stereo outputs.

All the switching possibilities are changed through the I²C bus.

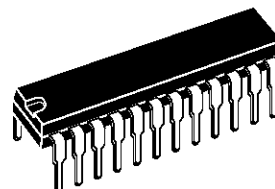

SHRINK24
(Plastic Package)

ORDER CODE : TEA6420

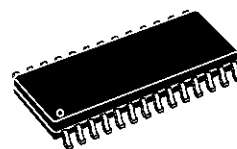

SO28
(Plastic Micropackage)

ORDER CODE : TEA6420D

PIN CONNECTIONS

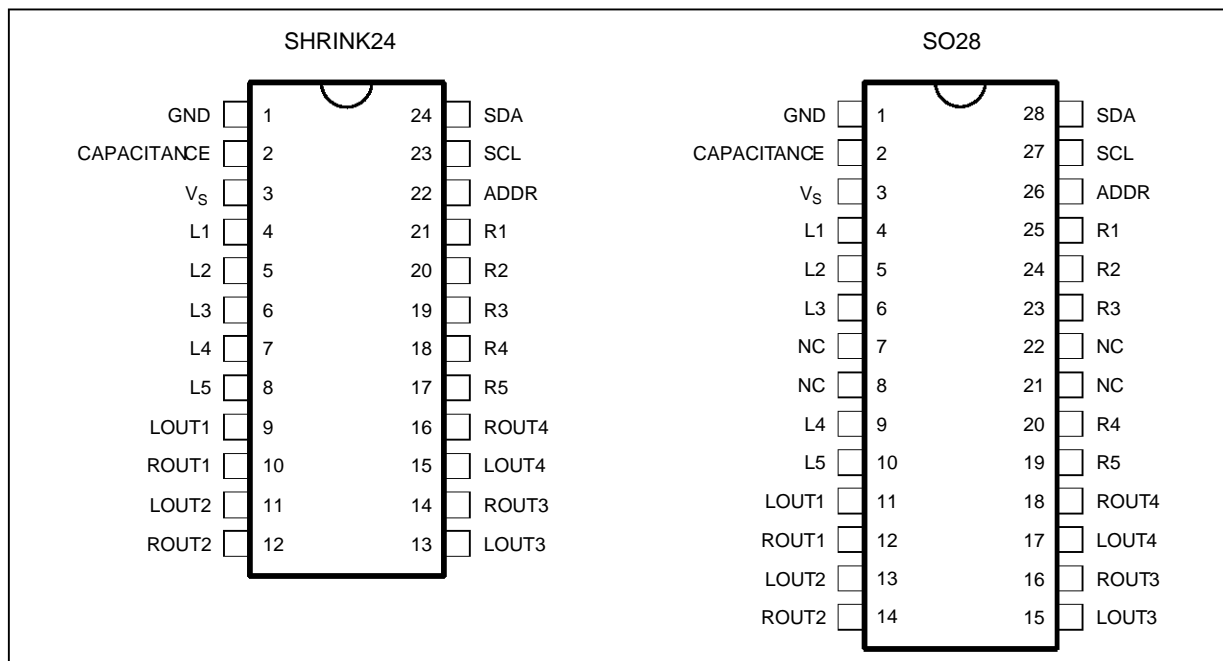

6420-01.EPS / 6420-02.EPS

BLOCK DIAGRAM

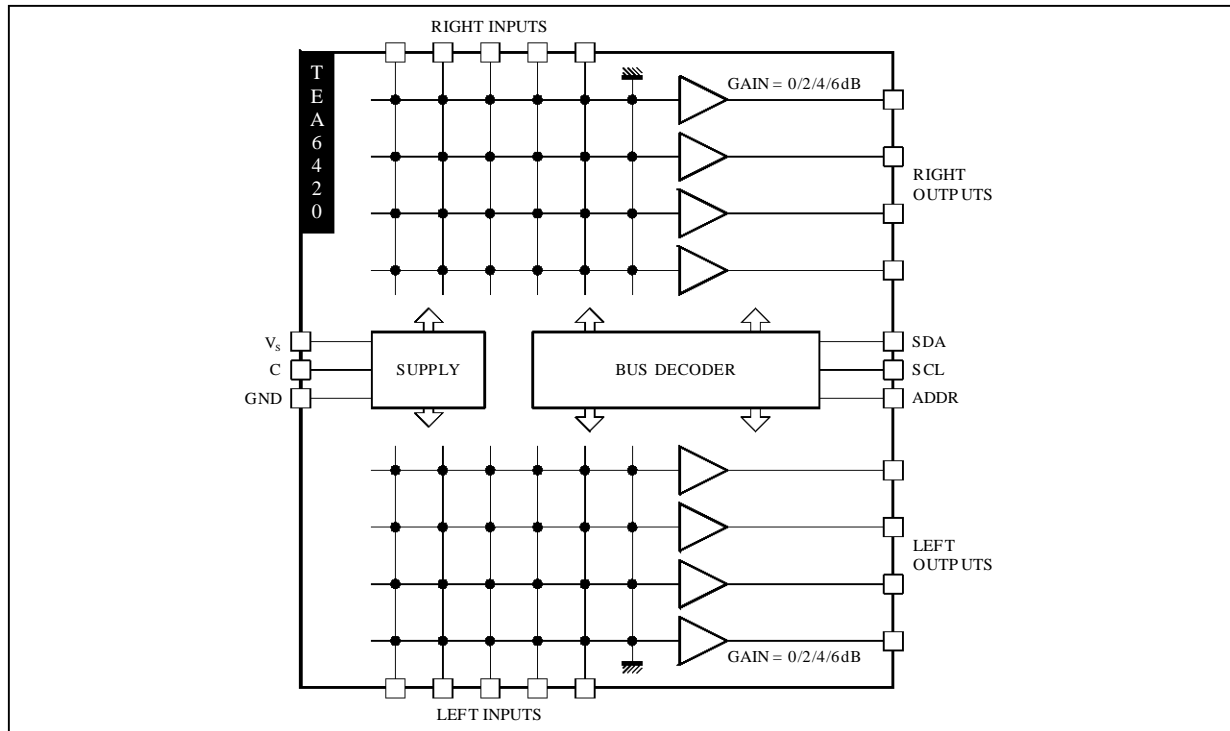

6420-03.EPS

ABSOLUTE MAXIMUM RATINGS

Symbol	Parameter	Value	Unit
V _{CC}	Supply Voltage	10.2	V
T _{oper}	Operating Ambient Temperature	0, + 70	°C
T _{stg}	Storage Temperature	- 20, + 150	°C

6420-01.TBL

THERMAL DATA

Symbol	Parameter	Value	Unit
R _{th(j-a)}	Junction Ambient Thermal Resistance	SHRINK24 SO28 75 75	°C/W

6420-02.TBL

ELECTRICAL CHARACTERISTICS

T_A = 25°C, V_S = 10V, R_L = 10kΩ, R_G = 600Ω, f = 1kHz (unless otherwise specified)

Symbol	Parameter	Test Conditions	Min.	Typ.	Max.	Unit
--------	-----------	-----------------	------	------	------	------

SUPPLY

V _S	Supply Voltage		8	9	10.2	V
I _S	Supply Current			5	8	mA
SVR	Ripple Rejection	V _{IN} = 500mV _{RMS} , BW = 20 - 20kHz	70	80		dB

MATRIX

V _{IN}	Input DC Level		4.5	5	5.5	V
R _I	Input Resistance		30	50	100	kΩ
C _S	Channel Separation	V _{IN} = 2V _{RMS} f = 1kHz	Gain = 0dB Gain = 6dB	80 70	90 82	dB dB

6420-03.TBL

ELECTRICAL CHARACTERISTICS (continued)

$T_A = 25^{\circ}\text{C}$, $V_S = 10\text{V}$, $R_L = 10\text{k}\Omega$, $R_G = 600\Omega$, $f = 1\text{kHz}$ (unless otherwise specified)

Symbol	Parameter	Test conditions	Min.	Typ.	Max.	Unit
OUTPUT BUFFER						
V_{OUT}	Output DC Level		4.5	5	5.5	V
R_{OUT}	Output Resistance			70	200	Ω
e_{NI}	Input Noise	BW = 20 - 20kHz, flat		3		μV
S/N	Signal to Noise Ratio	$V_{\text{IN}} = V_{\text{OUT}} = 1V_{\text{RMS}}$		110		dB
G_{min}	Min. Gain		-1	0	+1	dB
G_{max}	Max. Gain		5	6	7	dB
d	Distortion	$V_{\text{IN}} = V_{\text{OUT}} = 1V_{\text{RMS}}$		0.01	0.05	%
V_{CL}	Clipping Level	$d = 0.3\%$	2	2.5		V_{RMS}
R_L	Output Load Resistance		2			$\text{k}\Omega$

BUS INPUT

V_{IL}	Input Low Voltage				1.5	V
V_{IH}	Input High Voltage		3			V
I_{I}	Input Current		-10		10	μA
V_{O}	Output Voltage	$I_{\text{O}} = 3\text{mA}$; SDA Acknowledge pin			0.4	V
R_{pu}	ADDR Pullup Resistor	Note	40	50		$\text{k}\Omega$

Note : Rpu is an internal pull-up resistor connected between the address programming pin ADDR and the internal positive supply voltage. Leaving ADDR disconnected or "floating" allows it to become logic 1. Connecting ADDR externally to the GND pin forces it to logic 0.

SOFTWARE SPECIFICATION**1. Chip address**

Address	HEX	ADDR
1001 1000	98	0
1001 1010	9A	1

2. Data bytes

Output select								
X	0 0 1 1	0 1 0 1	G_1	G_0	I_2	I_1	I_0	Output 1 Output 2 Output 3 Output 4
Input select								
X	Q_1	Q_0	G_1	G_0	0 0 0 0 1 1	0 0 1 1 0 0	0 1 0 1 0 1	Input 1 Input 2 Input 3 Input 4 Input 5 Mute
Gain select								
X	Q_1	Q_0	0 0 1 1	0 1 0 1	I_2	I_1	I_0	Gain = 6 dB Gain = 4 dB Gain = 2 dB Gain = 0 dB

X = don't care

MSB is transmitted first

Example : 0 10 01 100 connects outputs 3 with input 5 at a gain of 4dB

The following are selected after power-on reset : input 5 selected for all outputs ; gain = 0dB.

TEA6420

TYPICAL APPLICATION (DIP package)

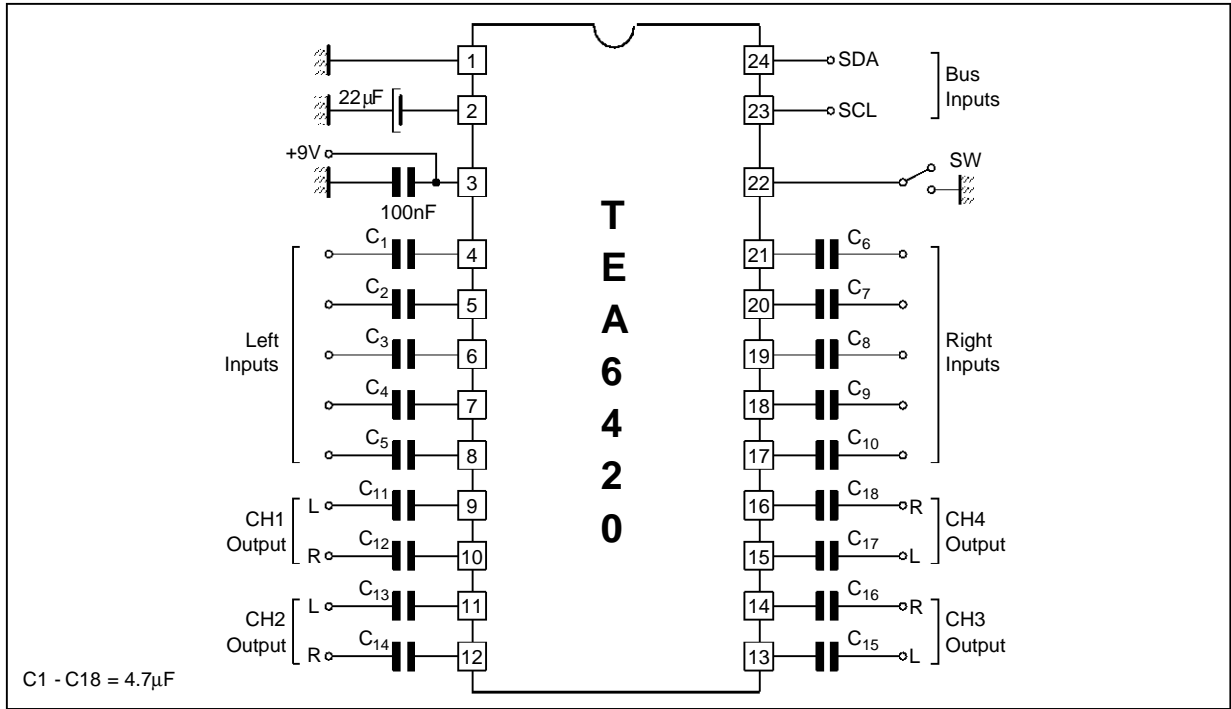

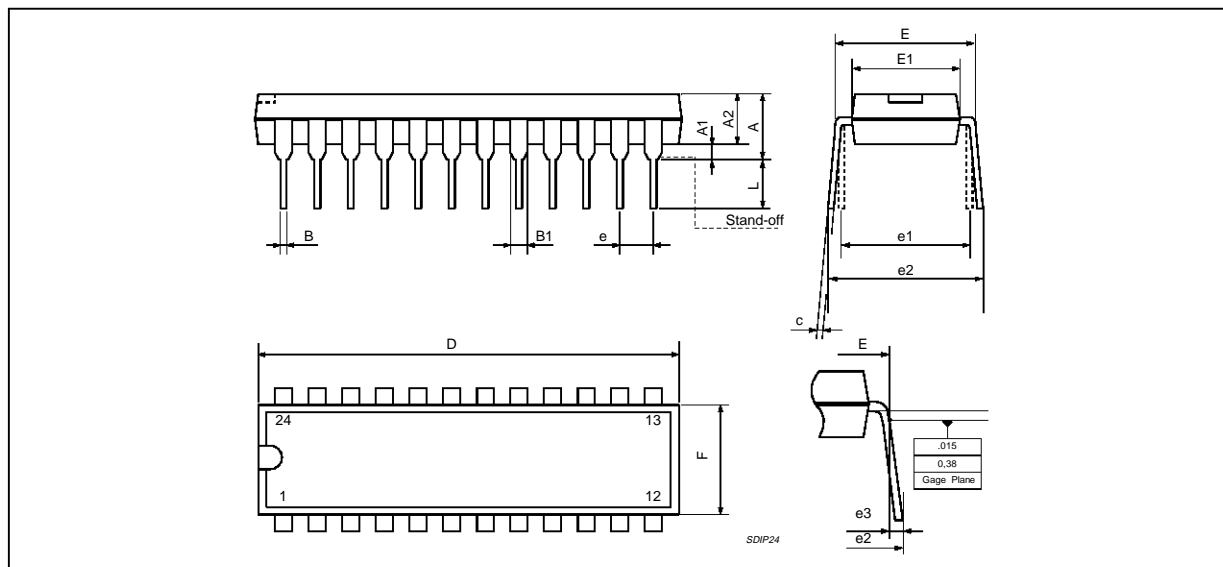
PACKAGE MECHANICAL DATA
 24 PINS - PLASTIC SHRINK

Dimensions	Millimeters			Inches		
	Min.	Typ.	Max.	Min.	Typ.	Max.
A			5.08			0.20
A1	0.51			0.020		
	3.05	3.30	4.57	0.120	0.130	0.180
B	0.36	0.46	0.56	0.0142	0.0181	0.0220
B1	0.76	1.02	1.14	0.030	0.040	0.045
C	0.23	0.25	0.38	0.0090	0.0098	0.0150
D	22.61	22.86	23.11	0.890	0.90	0.910
E	7.62		8.64	0.30		0.340
E1	6.10	6.40	6.86	0.240	0.252	0.270
e		1.778			0.070	
e1		7.62			0.30	
e2			10.92			0.430
e3			1.52			0.060
L	2.54	3.30	3.81	0.10	0.130	0.150

SDIP24.TBL

PACKAGE MECHANICAL DATA
28 PINS - PLASTIC MICROPACKAGE

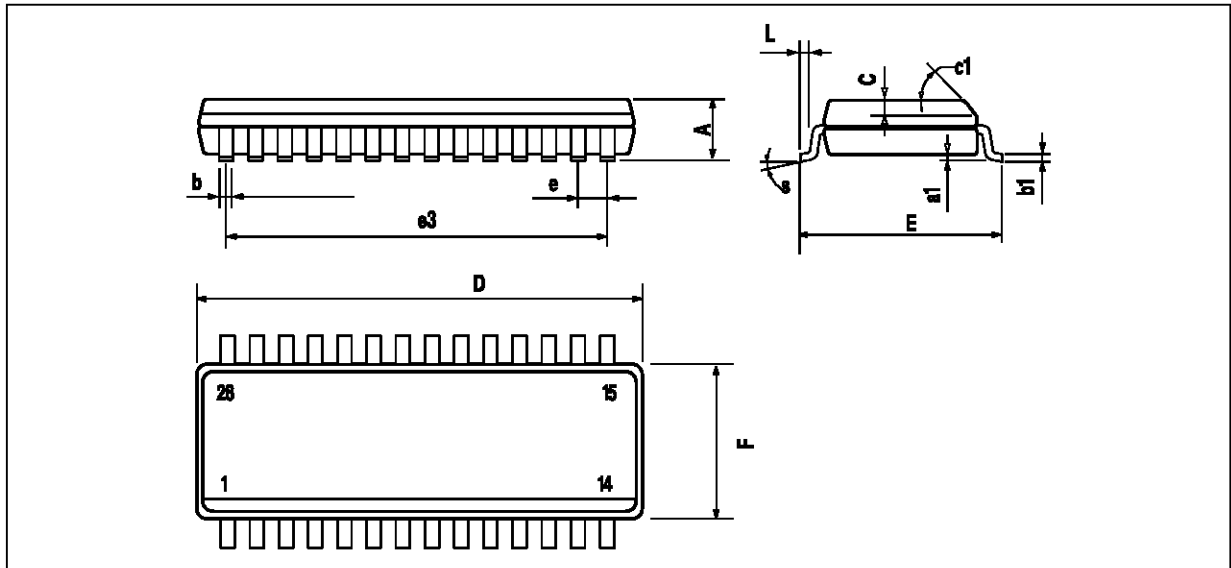

PM-SO28-EPS

Dimensions	Millimeters			Inches		
	Min.	Typ.	Max.	Min.	Typ.	Max.
A			2.65			0.104
a1	0.1		0.3	0.004		0.012
b	0.35		0.49	0.014		0.019
b1	0.23		0.32	0.009		0.013
C		0.5			0.020	
c1	45° (Typ.)					
D	17.7		18.1	0.697		0.713
E	10		10.65	0.394		0.419
e		1.27			0.050	
e3		16.51			0.65	
F	7.4		7.6	0.291		0.299
L	0.4		1.27	0.016		0.050
S	8° (Max.)					

SO28.TBL

Information furnished is believed to be accurate and reliable. However, SGS-THOMSON Microelectronics assumes no responsibility for the consequences of use of such information nor for any infringement of patents or other rights of third parties which may result from its use. No licence is granted by implication or otherwise under any patent or patent rights of SGS-THOMSON Microelectronics. Specifications mentioned in this publication are subject to change without notice. This publication supersedes and replaces all information previously supplied. SGS-THOMSON Microelectronics products are not authorized for use as critical components in life support devices or systems without express written approval of SGS-THOMSON Microelectronics.

© 1996 SGS-THOMSON Microelectronics - All Rights Reserved

Purchase of I²C Components of SGS-THOMSON Microelectronics, conveys a license under the Philips I²C Patent. Rights to use these components in a I²C system, is granted provided that the system conforms to the I²C Standard Specifications as defined by Philips.

SGS-THOMSON Microelectronics GROUP OF COMPANIES

Australia - Brazil - Canada - China - France - Germany - Hong Kong - Italy - Japan - Korea - Malaysia - Malta - Morocco
The Netherlands - Singapore - Spain - Sweden - Switzerland - Taiwan - Thailand - United Kingdom - U.S.A.