

**LA1806**

AM/FM-IF/MPX Tuner System for Radio-Cassette Recorders, Music Centers

Overview

The LA1806 is a characteristics-improved version of the LA1811, with the same pin assignment and package as those of the LA1811. Improvements are made on the following points:

- Separation (35 dB → 48 dB) and its dependence on free-running frequency (Refer to the separate catalog of the LA1805.)
- FM main distortion (0.8% → 0.45%)
- AM detection output (approximately 5 dB increased)

The constants on five external parts are changed as LA1811

Functions

- FM-IF: IF amplifier quadrature detector, soft muting, tuning indicator
- MPX: PLL stereo decoder, stereo indicator, forced monaural, VCO stop
- AM: RF amplifier, MIX, OSC (with ALC), IF amplifier, detector, AGC, tuning indicator

Features

- FM/AM/MPX functions contained on a single chip
- Minimum number of external parts required
- On-chip FM muting function
- High sensitivity
- Less carrier leak of MPX

Specifications

Maximum Ratings at $T_a = 25^\circ\text{C}$, See specified Test Circuit

Parameter	Symbol	Conditions	Ratings	Unit
Maximum supply voltage	$V_{CC \text{ max}}$	Pins 3, 7, 8, 11, 20, 21	9	V
Maximum supply current	$I_{CC \text{ max}}$	Pins 3 + 20 + 21	50	mA
Flow-in current (Indicator drive current)	I_{LED}	Pins 7, 8	20	mA
Flow-out current	I_{23}	Pin 23	0.1	mA
Allowable power dissipation	$P_d \text{ max}$	$T_a \leq 70^\circ\text{C}$	500	mW
Operating temperature	T_{opr}		-20 to +70	$^\circ\text{C}$
Storage temperature	T_{stg}		-40 to +125	$^\circ\text{C}$

Package Dimensions

unit : mm

3067-DIP24S

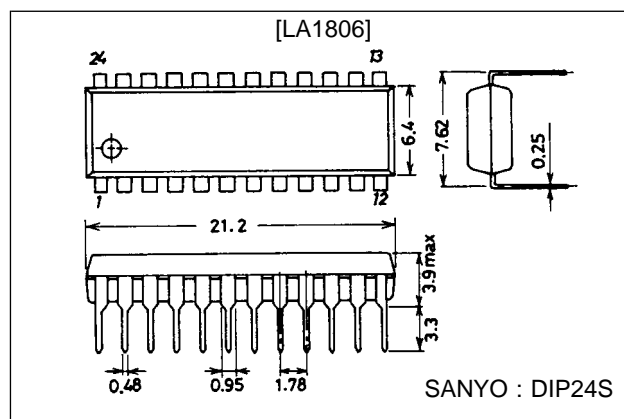

LA1806

Operating Conditions at Ta = 25°C

Parameter	Symbol	Conditions	Ratings	Unit
Recommended supply voltage	V _{CC}		4.5	V
Operating voltage range	V _{CCOP}		3.0 to 8.0	V

* The FM output level forms an N curve (LA1805) and an S curve (LA1806).

LA1805: N curve (for US band)

LA1806: S curve (for Japanese band). Since an output load resistor is connected to pins 9, 10 externally, your desired output level can be set by varying the output resistance.

Operating Characteristics at Ta = 25°C, V_{CC} = 4.5 V, See specified Test Circuit.

Parameter	Symbol	Conditions	min	typ	max	Unit
FM characteristics (Mono): f _c = 10.7 MHz, f _m = 1 kHz						
Quiescent current	I _{CCO}	No input		13	20	mA
-3 dB sensitivity	-3dBLS.	Referenced to V _{IN} = 100 dBμ, 100%, down 3 dB		28	35	dBμ
Demodulation output	V ₀	V _{IN} = 100 dBμ, 100% mod.	154	226	308	mV
Channel balance	C.B.	V _{IN} = 100 dBμ, 100% mod.	0	0	1.5	dB
Total harmonic distortion	THD	V _{IN} = 100 dBμ, 100% mod.		0.45	1.2	%
Signal to noise ratio	S/N	V _{IN} = 100 dBμ, 100% mod.	70	80		dB
LED ON sensitivity	V _{LED}	I _L = 1 mA	23	33	43	dBμ
FM Characteristics (Stereo) : f _c = 10.7 MHz, f _m = 1 kHz, L + R = 90%, pilot = 10%, V _{IN} = 100 dBμ						
Separation	Sep		32	48		dB
Stereo distortion	THD (MAIN)			0.45	1.2	%
LED ON level	V _{LED-on}		2.4	3.9	5.4	%
LED OFF level	V _{LED-off}			2.7		%
AM Characteristics: f _c = 1000 kHz, f _m = 1 kHz						
Quiescent current	I _{CCO}	No input		9.5	14.5	mA
Detection output	V _{O1}	V _{IN} = 23 dBμ, 30% mod.	29	54	97	mV
	V _{O2}	V _{IN} = 80 dBμ, 30% mod.	78	126	193	mV
Signal to noise ratio	S/N1	V _{IN} = 23 dBμ, 30% mod.	17	21		dB
	S/N2	V _{IN} = 80 dBμ, 30% mod.	50	55		dB
Total harmonic distortion	THD1	V _{IN} = 80 dBμ, 30% mod.		0.45	1.2	%
	THD2	V _{IN} = 100 dBμ, 30% mod.		0.6	1.5	%
LED ON sensitivity	V _{LED}	I _L = 1 mA Note : Be fully careful of dielectric breakdown.	16	24	32	dBμ

Note : For further details, refer to the separate catalog of the LA1805.

LA1806

Equivalent Circuit Block Diagram

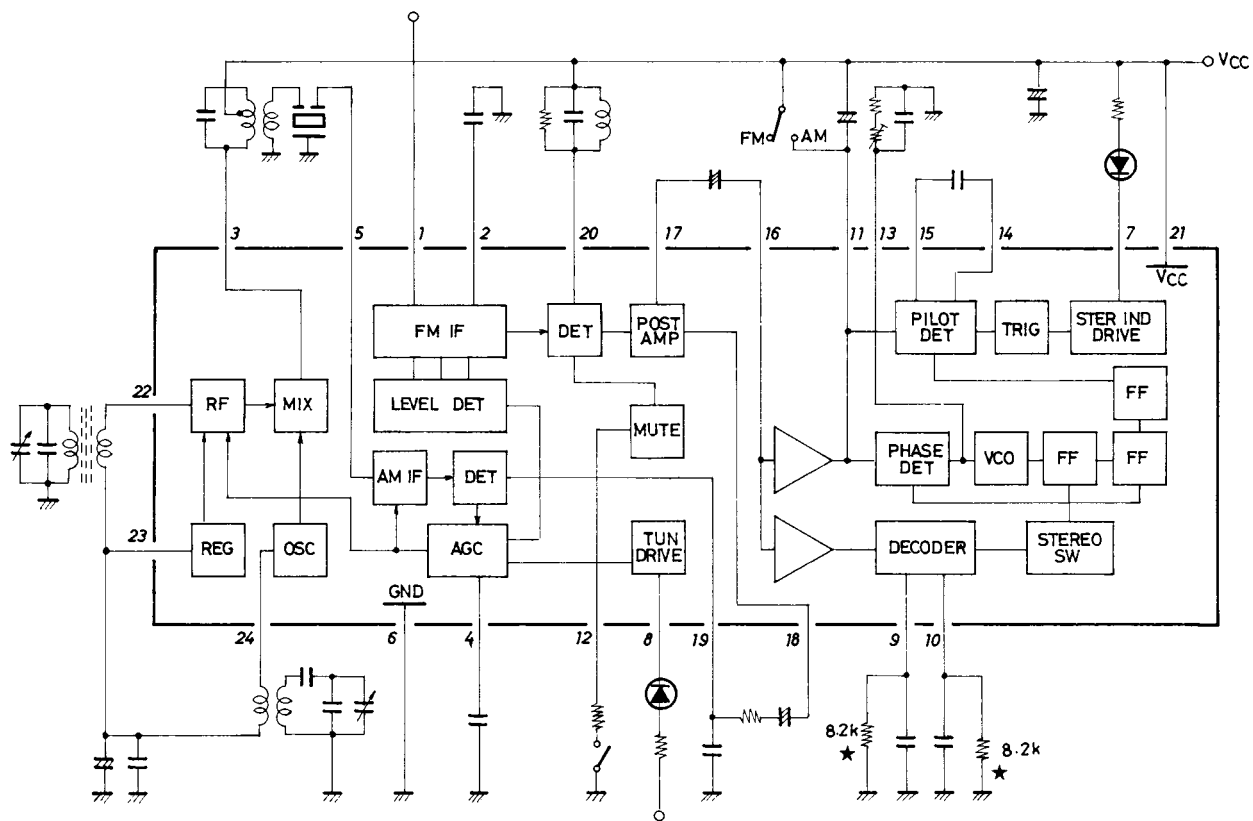

★:Not required for the LA1805

Unit (resistance: Ω)

LA1806

Test Circuit

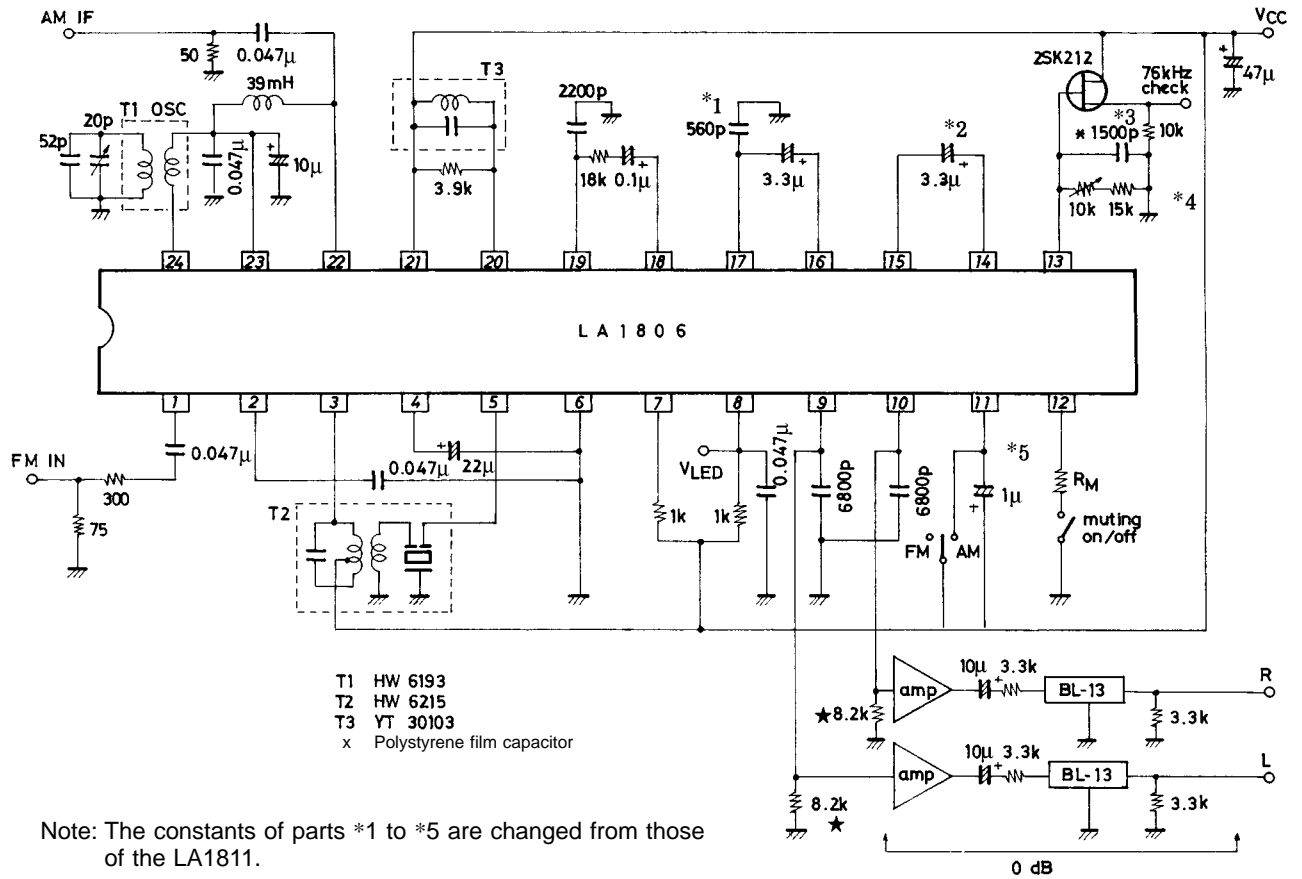

- No products described or contained herein are intended for use in surgical implants, life-support systems, aerospace equipment, nuclear power control systems, vehicles, disaster/crime-prevention equipment and the like, the failure of which may directly or indirectly cause injury, death or property loss.
- Anyone purchasing any products described or contained herein for an above-mentioned use shall:
 - ① Accept full responsibility and indemnify and defend SANYO ELECTRIC CO., LTD., its affiliates, subsidiaries and distributors and all their officers and employees, jointly and severally, against any and all claims and litigation and all damages, cost and expenses associated with such use:
 - ② Not impose any responsibility for any fault or negligence which may be cited in any such claim or litigation on SANYO ELECTRIC CO., LTD., its affiliates, subsidiaries and distributors or any of their officers and employees jointly or severally.
- Information (including circuit diagrams and circuit parameters) herein is for example only; it is not guaranteed for volume production. SANYO believes information herein is accurate and reliable, but no guarantees are made or implied regarding its use or any infringements of intellectual property rights or other rights of third parties.

This catalog provides information as of January, 1997. Specifications and information herein are subject to change without notice.