



# PMB 6811

## S/M POWER

### Power Management for Cellular Systems

S/M POWER is a highly integrated Power and Battery Management IC for mobile handsets and provides all power supply functions for complete systems ranging from GSM over GPRS up to EDGE smart phones and modules.

It has been optimized for usage with Infineon's S-GOLD family based systems in conjunction with cellular RF transceiver like SMARTi-DC+ and SMARTi-SD as well as Infineon's single chipsolution for Bluetooth. The low power system performance required in market demanding feature rich terminals can be ensured with this advanced power management concept at best in class system costs and highest system integration level.

#### Applications

- System Powermanagement IC for all GSM/GPRS/EDGE Mobile Phones and Data Modules

#### Features

- Support of dedicated standby power-down concept for S-GOLD family
- Charger for NiMH and Li-Ion/Polymer batteries including precharge current generator
- Highly efficient DC/DC step-down converter
- Low-drop-out (LDO) regulators for system memory devices
- LDO regulators for baseband I/O supply
- Low-noise LDO regulators for RF devices
- LDO regulator for analog mixed-signal section of S-GOLD
- Supply for Infineon's single chip solution Bluemoon Single
- USB interface support for peripheral and mini-host mode
- Vibra driver fully programable
- 400 mW Audio amplifier for handsfree and Polyringer
- RTC regulator with ultra-low quiescent current
- Backlight LEDs driver with dimming function
- Two single LED driver outputs for signalling
- Fully controllable by software via I<sup>2</sup>C-Bus
- Interrupt channels for peripherals
- System debug mode
- Based on robust 0.5 μm BiCMOS technology

#### Package

- P-VQFN48-4 package with heat sink and non-protruding leads
- Smallest board footprint of 7x7 mm
- Superior thermal characteristics can handle up to 2 Watt

#### Documentation/Development and Support Tools

- Product Overview
- Specification
- User Manual
- Application Note
- Evaluation Board

[www.infineon.com/mobilesolutions](http://www.infineon.com/mobilesolutions)

## Mobile Solutions



Never stop thinking.

## Top Level Architecture for S/M POWER

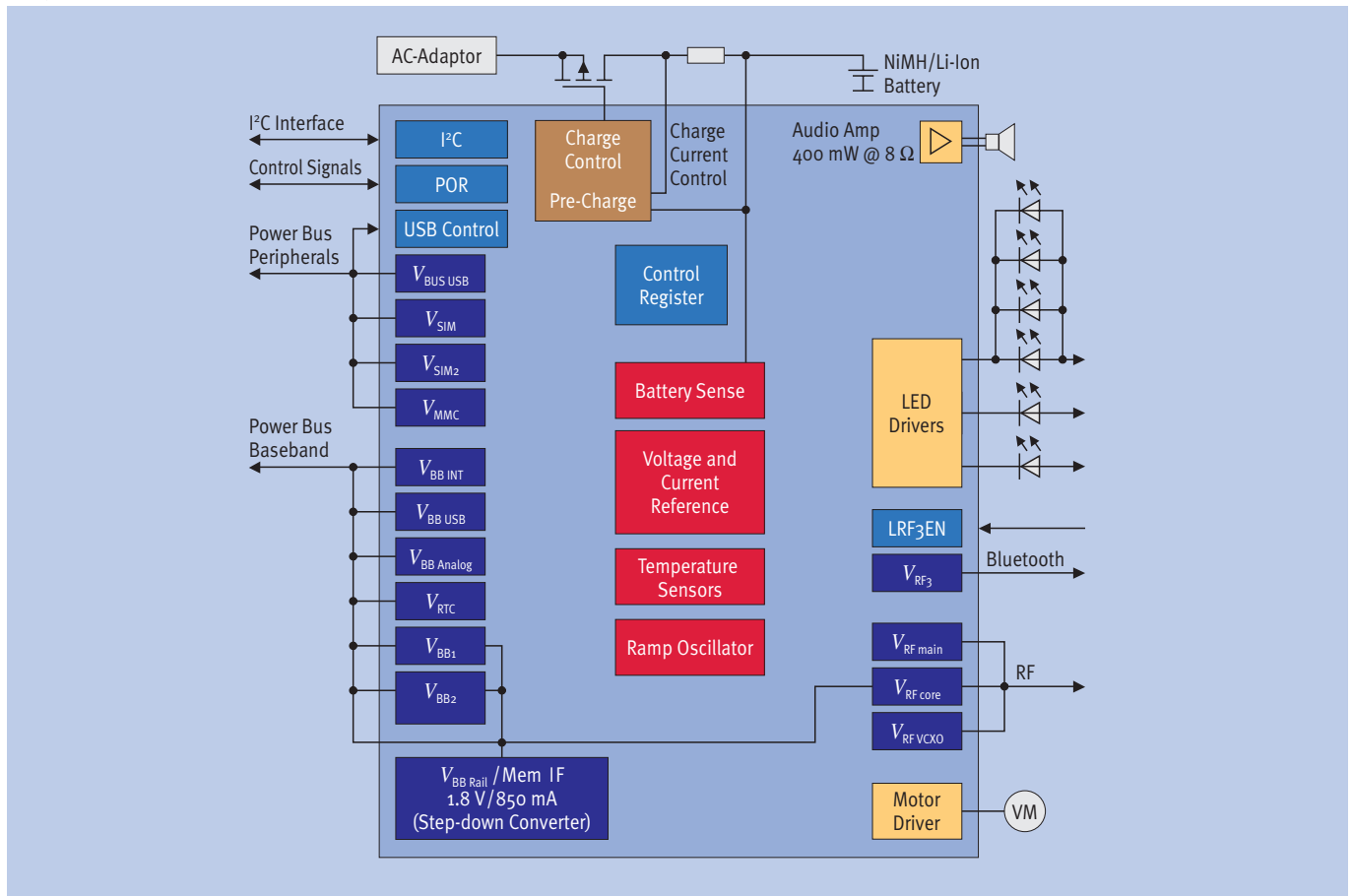

How to reach us:  
<http://www.infineon.com>

Published by  
**Infineon Technologies AG,**  
 St.-Martin-Strasse 53,  
 D-81669 München

© Infineon Technologies AG 2004.  
 All Rights Reserved.

Template: pb\_tmplt.fm/4/2004-01-01

### Attention please!

The information herein is given to describe certain components and shall not be considered as a guarantee of characteristics. Terms of delivery and rights to technical change reserved.

We hereby disclaim any and all warranties, including but not limited to warranties of non-infringement, regarding circuits, descriptions and charts stated herein.

### Information

For further information on technology, delivery terms and conditions and prices please contact your nearest Infineon Technologies Office.

### Warnings

Due to technical requirements components may contain dangerous substances. For information on the types in question please contact your nearest Infineon Technologies Office.

Infineon Technologies Components may only be used in life-support devices or systems with the express written approval of Infineon Technologies, if a failure of such components can reasonably be expected to cause the failure of that life-support device or system, or to affect the safety or effectiveness of that device or system. Life support devices or systems are intended to be implanted in the human body, or to support and/or maintain and sustain and/or protect human life. If they fail, it is reasonable to assume that the health of the user or other persons may be endangered.

Ordering No. B134-H8155-G1-X-7600  
 Printed in Germany  
 PS 01042. NB