

Single-phase full-wave motor driver for fan motor

BA6908F

BA6908F is a single phase full-wave motor driver for fan motor corresponding to 5V and 12V. Switching noise is reduced by soft switching drive. This IC has lock detection and automatic restart functions as motor protection function.

●Applications

Motor drivers for fan motors

●Features

- 1) Single-phase full-wave drive system.
- 2) Built-in power transistor.
- 3) Soft switching drive.
- 4) Lock detection and automatic restart circuit.
- 5) Thermal shut-down circuit.
- 6) Hall signal output.

●Absolute maximum ratings (Ta=25°C)

Parameter	Symbol	Limits	Unit
Supply voltage	V _{CC}	15	V
Power dissipation	P _d	687 *1	mW
Operating temperature	T _{opr}	-40 to +85	°C
Storage temperature	T _{stg}	-55 to +150	°C
Output current	I _{OUT}	0.7 *2	A
Hall signal output current	I _{HO}	15	mA
Output voltage	V _{OUT}	15	V
Hall signal output voltage	V _{HO}	15	V
Junction temperature	T _{jmax}	150	°C

*1 To use at temperature above Ta=25°C reduce 5.5mW/°C.
(On 70.0mm×70.0mm×1.6mm glass epoxy board)

*2 This value is not to be over P_d and ASO.

●Recommended operating conditions (Ta=25°C)

Parameter	Symbol	Min.	Typ.	Max.	Unit
Supply voltage	V _{CC}	3	–	14	V

Motor driver ICs

●Block diagram

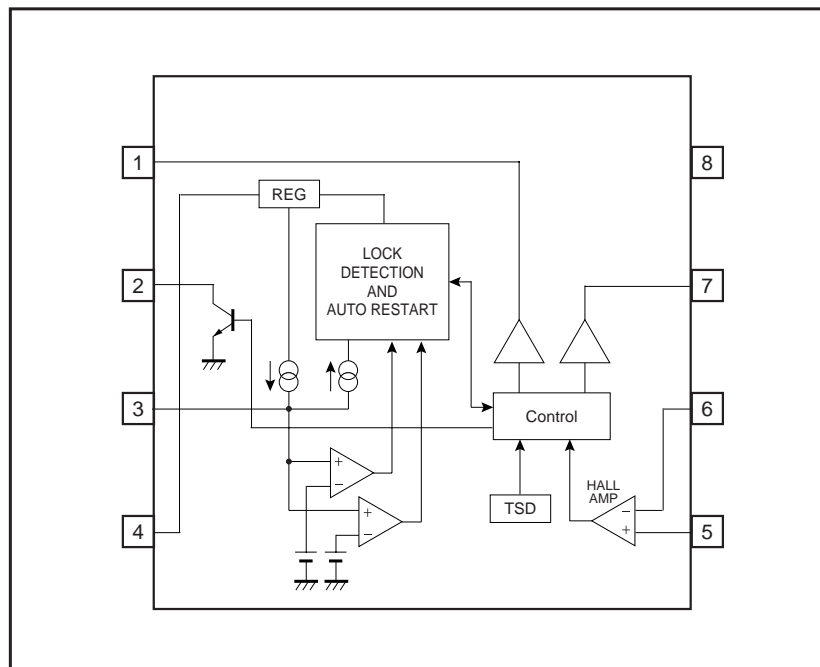

●Terminal function table

Pin No.	Pin name	Function
1	OUT2	Output terminal 2
2	HO	Hall signal output terminal
3	LD	Connection terminal of capacitor for lock detection, auto restart
4	V _{cc}	Power supply terminal
5	H+	Hall signal input terminal +
6	H-	Hall signal input terminal -
7	OUT1	Output terminal 1
8	GND	GROUND terminal

Motor driver ICs

●Input / output circuit

<Hall input>

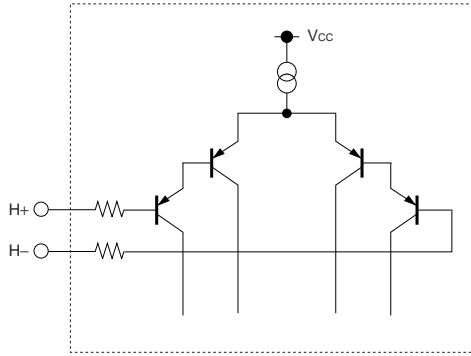

Fig.1

<Coil output>

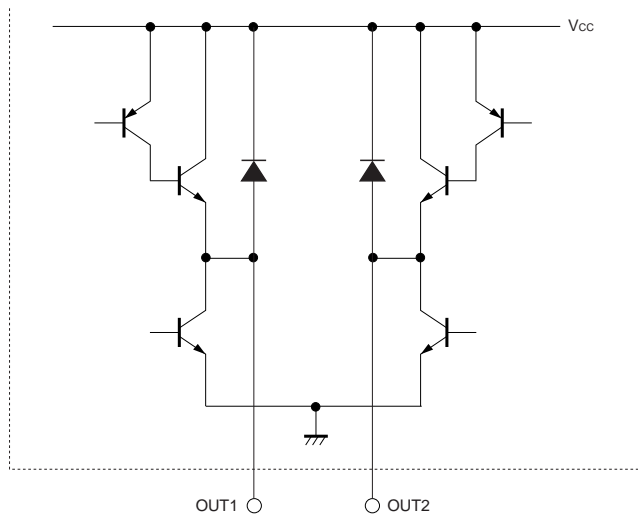

Fig.2

<HO output>

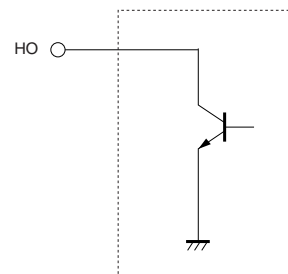

Fig.3

Motor driver ICs

●Electrical characteristics (Unless otherwise specified, Ta=25°C, Vcc=5V)

Parameter	Symbol	Min.	Typ.	Max.	Unit	Conditions
Supply current	I _{cc}	1.5	3.4	8.7	mA	At output : OFF
Charge current of capacitor for lock detection	ILDC	1.50	2.75	4.50	μA	VLD=1.1V
Discharge current of capacitor for lock detection	ILDD	0.24	0.48	0.90	μA	VLD=1.1V
Charge-discharge current ratio of capacitor for lock detection	rCD	4.2	5.7	9.5	–	rCD=ILDC/ILDD
Clamp voltage of capacitor for lock detection	VLDCL	1.14	1.80	2.47	V	
Comparison voltage of capacitor for lock detection	VLDCP	0.47	0.76	1.06	V	
Output voltage L	VOL	–	0.2	0.3	V	I _o =200mA
Output voltage H	VOH	3.9	4.1	–	V	I _o =200mA
"HO" terminal voltage L	VHOL	–	0.3	0.5	V	IHO=5mA
"HO" terminal leak current	IHOL	–	0	50	μA	VHO=15V
Hall input offset voltage	Hofs	–10	–	10	mV	
Hall input-output gain	GHO	320	500	680	–	

© This product is not designed for protection against radioactive rays.

●Lock detect circuit, automatic restart circuit

Charge and discharge time at motor lock condition varies with the value of external capacitor at LD terminal and is given by the following equation.

$$T_{on} \text{ (Charge time)} = \frac{C \cdot (VLDCL - VLDCP)}{ILDC}$$

$$T_{off} \text{ (Discharge time)} = \frac{C \cdot (VLDCL - VLDCP)}{ILDD}$$

- C : Value of capacitor at LD terminal
 VLDCL : Clamp voltage of capacitor lock detection (1.80V Typ.)
 VLDCP : Comparison voltage of capacitor lock detection (0.76V Typ.)
 ILDC : Charge current of capacitor lock detection (2.75μA Typ.)
 ILDD : Discharge current of capacitor lock detection (0.48μA Typ.)

The following value shows charge time and discharge time at C=0.47μF for reference.

Charge time = 0.18SEC (Output : ON)
 Discharge time = 1.02SEC (Output : OFF)

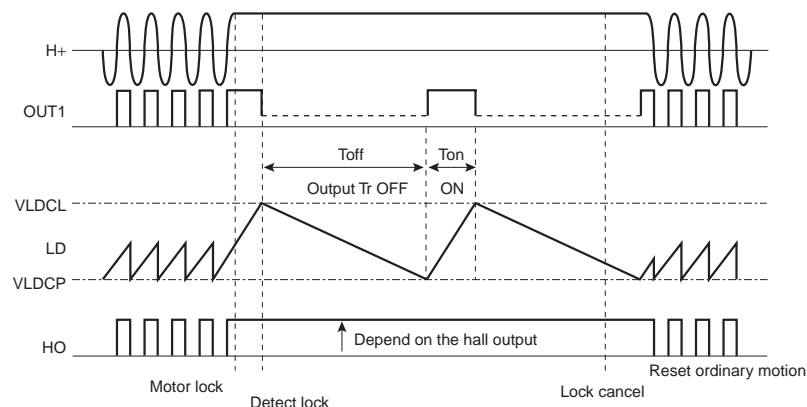

Fig.4 Timing chart

Motor driver ICs

●Application circuit

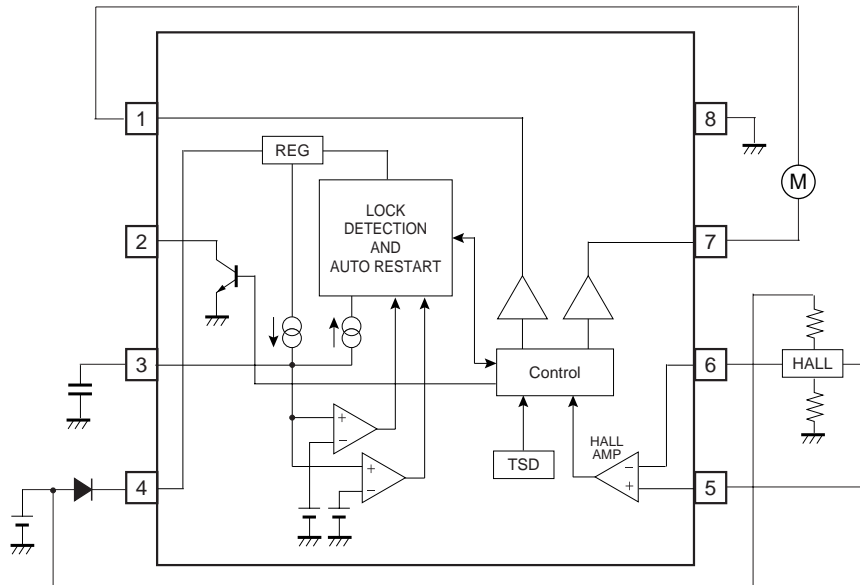

Fig.5

●Cautions

- 1) Thermal shut down(TSD)
This IC is built-in TSD.
TSD has the temperature hysteresis.

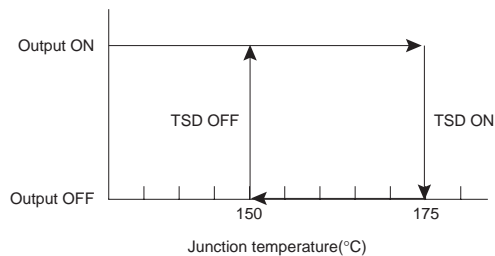

Fig.6 TSD

TSD ON (Typ. : 175°C)
All output transistor OFF.

TSD OFF (Typ. : 150°C)
Reset ordinary motion.
(It has the temperature hysteresis of 25°C<TYP>)

- 2) Power dissipation
IC power dissipation widely varies with supply voltage, output current and application of IC. Please be careful for the thermal design not to exceed the allowable power dissipation.

Motor driver ICs

3) Hall signal input terminals (H+, H-)

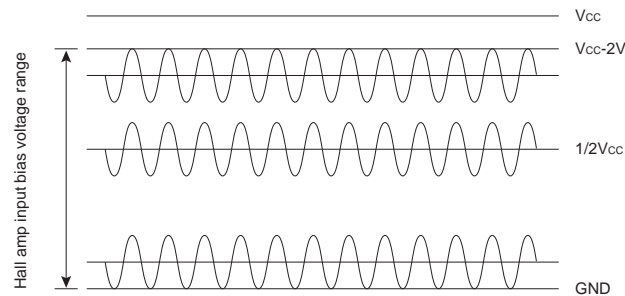

Fig.7 Hall amp input bias voltage range.

- A. Please adjust hall input bias voltage by value of resistor for hall element, so that hall signal contains amplitude input within rang from 0V to $V_{cc}-2V$. At this time, to set hall amp input bias voltage for $V_{cc}/2$ is recommended.
- B. Please be careful of input signal because hall amp of this IC doesn't have input hysteresis.
- C. The output signal of this IC is the amplified hall input signal. Therefore, the output signal depends on hall input signal. When the amplitude of hall signal is small, the output signal becomes gentle. Oppositely, when the amplitude is big, the output signal becomes steep. The hall-input/output gain is about 500 times (TYP), so please input the hall signal that is suitable to make adequate amplitude of the output signal.

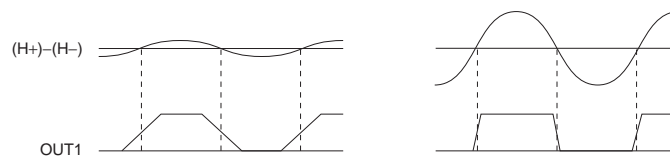

Fig.8 Difference of output signal depending on hall input signal

- 4) ASO
Please consider output transistors not to exceed absolute maximum ratings and ASO.
- 5) GND
Please keep up the voltage of GND less than the voltage of another terminal surely.
- 6) This product is produced with strict quality control, but destroyed in using beyond absolute maximum ratings. Once IC destroyed, a failure mode cannot be defined (like short-mode or open-mode). Therefore, physical security counter measure like fuse is to be given when a specific mode to be beyond absolute maximum ratings is considered.

Motor driver ICs

●Electrical characteristic curves

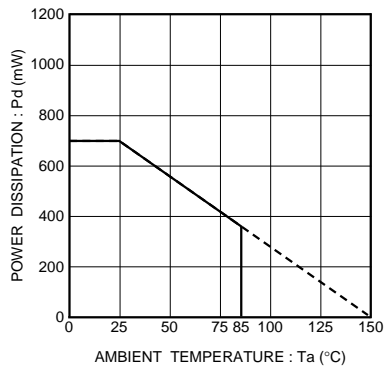

Fig.9 Power dissipation curve

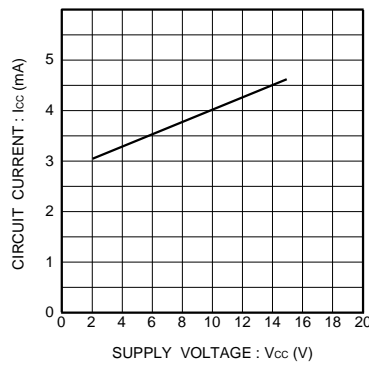

Fig.10 Circuit current vs. Power supply voltage

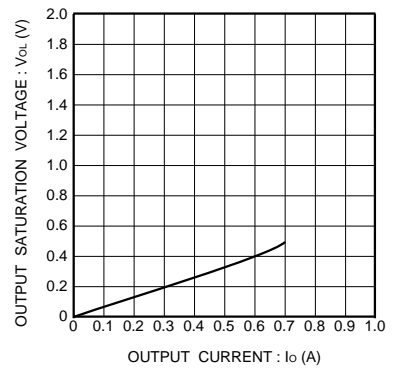

Fig.11 Low level saturation voltage vs. Output current

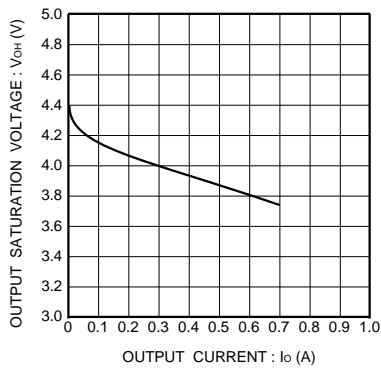
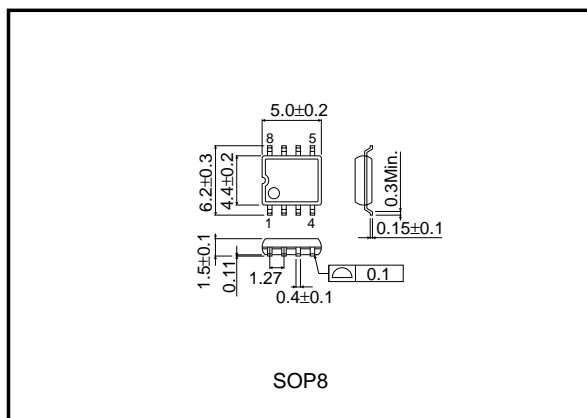

Fig.12 High level saturation voltage vs. Output current

●External dimensions (Unit : mm)



Notes

- No technical content pages of this document may be reproduced in any form or transmitted by any means without prior permission of ROHM CO.,LTD.
- The contents described herein are subject to change without notice. The specifications for the product described in this document are for reference only. Upon actual use, therefore, please request that specifications to be separately delivered.
- Application circuit diagrams and circuit constants contained herein are shown as examples of standard use and operation. Please pay careful attention to the peripheral conditions when designing circuits and deciding upon circuit constants in the set.
- Any data, including, but not limited to application circuit diagrams information, described herein are intended only as illustrations of such devices and not as the specifications for such devices. ROHM CO.,LTD. disclaims any warranty that any use of such devices shall be free from infringement of any third party's intellectual property rights or other proprietary rights, and further, assumes no liability of whatsoever nature in the event of any such infringement, or arising from or connected with or related to the use of such devices.
- Upon the sale of any such devices, other than for buyer's right to use such devices itself, resell or otherwise dispose of the same, no express or implied right or license to practice or commercially exploit any intellectual property rights or other proprietary rights owned or controlled by
- ROHM CO., LTD. is granted to any such buyer.
- Products listed in this document are no antiradiation design.

The products listed in this document are designed to be used with ordinary electronic equipment or devices (such as audio visual equipment, office-automation equipment, communications devices, electrical appliances and electronic toys).

Should you intend to use these products with equipment or devices which require an extremely high level of reliability and the malfunction of which would directly endanger human life (such as medical instruments, transportation equipment, aerospace machinery, nuclear-reactor controllers, fuel controllers and other safety devices), please be sure to consult with our sales representative in advance.

About Export Control Order in Japan

Products described herein are the objects of controlled goods in Annex 1 (Item 16) of Export Trade Control Order in Japan.

In case of export from Japan, please confirm if it applies to "objective" criteria or an "informed" (by MITI clause) on the basis of "catch all controls for Non-Proliferation of Weapons of Mass Destruction.