

MOS INTEGRATED CIRCUIT
 μ PD754202, 754202(A)**4-BIT SINGLE-CHIP MICROCONTROLLERS**

The μ PD754202 is a member of the 75XL Series of 4-bit single-chip microcontrollers that enable data processing equivalent to that of an 8-bit microcontroller.

It features expanded CPU functions compared to the 75X Series and enables high-speed, low-voltage operation at 1.8 V, making it suitable for battery-driven applications.

The μ PD754202(A) is a higher-reliability product compared to the μ PD754202.

Detailed function descriptions, etc., are provided in the following user's manual. Be sure to read it when designing.

μ PD754202 User's Manual: U11132E

FEATURES

- Key return reset function for keyless entry
- Low-voltage operation: $V_{DD} = 1.8$ to 6.0 V
- On-chip memory
 - Program memory (ROM): 2048×8 bits
 - Data memory (RAM) : 128×4 bits
- Variable instruction execution time useful for high-speed operation and power save
 - $0.95, 1.91, 3.81, 15.3 \mu s$ (at 4.19-MHz operation)
 - $0.67, 1.33, 2.67, 10.7 \mu s$ (at 6.0-MHz operation)
- Compact package (20-pin plastic shrink SOP (300 mil, 0.65-mm pitch))

APPLICATIONS

Automotive electronics such as keyless entry units

The μ PD754202 and μ PD754202(A) have different quality grades. Unless otherwise specified, descriptions in this data sheet apply to the μ PD754202.

The information in this document is subject to change without notice.

ORDERING INFORMATION

Part Number	Package	Quality Grade
μPD754202GS-xxx-BA5	20-pin plastic SOP (300 mil, 1.27-mm pitch)	Standard
μPD754202GS-xxx-GJG	20-pin plastic shrink SOP (300 mil, 0.65-mm pitch)	Standard
μPD754202GS(A)-xxx-BA5	20-pin plastic SOP (300 mil, 1.27-mm pitch)	Special
μPD754202GS(A)-xxx-GJG	20-pin plastic shrink SOP (300 mil, 0.65-mm pitch)	Special

Remark xxx indicates the ROM code suffix.

Please refer to "Quality Grades on NEC Semiconductor Devices" (Document No. C11531E) published by NEC Corporation to know the specification of quality grade on the devices and its recommended applications.

Differences between μPD754202 and μPD754202(A)

Part Number	μPD754202	μPD754202(A)
Item		
Quality grade	Standard	Special

FUNCTION LIST

Parameter		Function	
Instruction execution time		<ul style="list-style-type: none"> • 0.95, 1.91, 3.81, 15.3 μs (system clock: at 4.19-MHz operation) • 0.67, 1.33, 2.67, 10.7 μs (system clock: at 6.0-MHz operation) 	
On-chip memory	ROM	2048 × 8 bits	
	RAM	128 × 4 bits	
General-purpose register		<ul style="list-style-type: none"> • 4-bit manipulation: 8 × 4 banks • 8-bit manipulation: 4 × 4 banks 	
I/O port	CMOS input	4	Mask option-specifiable on-chip pull-up resistor
	CMOS input/output	9	Software-specifiable on-chip pull-up resistor connection
	Total	13	
Timer		4 channels <ul style="list-style-type: none"> • 8-bit timer counter: 3 channels (Usable as 16-bit timer counter) • Basic interval timer/watchdog timer: 1 channel 	
Bit sequential buffer (BSB)		16 bits	
Vectored interrupt		External: 1, Internal: 4	
Test input		External: 1 (key return reset function provided)	
System clock oscillation circuit		Ceramic/crystal oscillation circuit	
Standby function		STOP/HALT mode	
Operating ambient temperature		T _A = -40 to +85 °C	
Supply voltage		V _{DD} = 1.8 to 6.0 V	
Package		<ul style="list-style-type: none"> • 20-pin plastic SOP (300 mil, 1.27-mm pitch) • 20-pin plastic shrink SOP (300 mil, 0.65-mm pitch) 	

CONTENTS

1. PIN CONFIGURATION (Top View)	6
2. BLOCK DIAGRAM	7
3. PIN FUNCTION	8
3.1 Port Pins	8
3.2 Non-port Pins	9
3.3 Pin Input/Output Circuits	10
3.4 Recommended Connection of Unused Pins	11
4. SWITCHING FUNCTION BETWEEN Mk I MODE AND Mk II MODE	12
4.1 Differences between Mk I Mode and Mk II Mode	12
4.2 Setting Method of Stack Bank Select Register (SBS)	13
5. MEMORY CONFIGURATION	14
6. PERIPHERAL HARDWARE FUNCTION	17
6.1 Digital I/O Port	17
6.2 Clock Generator	17
6.3 Basic Interval Timer/Watchdog Timer	19
6.4 Timer Counter	20
6.5 Bit Sequential Buffer	24
7. INTERRUPT FUNCTION AND TEST FUNCTION	25
8. STANDBY FUNCTION	27
9. RESET FUNCTION	28
9.1 Configuration and Operation Status of Reset Function	28
9.2 Watchdog Flag (WDF), Key Return Flag (KRF)	32
10. MASK OPTION	34
11. INSTRUCTION SETS	35
12. ELECTRICAL SPECIFICATIONS	44
13. CHARACTERISTIC CURVES (REFERENCE VALUES)	53
14. PACKAGE DRAWINGS	55
15. RECOMMENDED SOLDERING CONDITIONS	57

APPENDIX A. μPD754202, 75F4264 FUNCTION LIST58

APPENDIX B. DEVELOPMENT TOOLS59

APPENDIX C. RELATED DOCUMENTS62

1. PIN CONFIGURATION (Top View)

- 20-pin plastic SOP (300 mil, 1.27-mm pitch)
 μPD754202GS-xxx-BA5
 μPD754202GS(A)-xxx-BA5
- 20-pin plastic shrink SOP (300 mil, 0.65-mm pitch)
 μPD754202GS-xxx-GJG
 μPD754202GS(A)-xxx-GJG

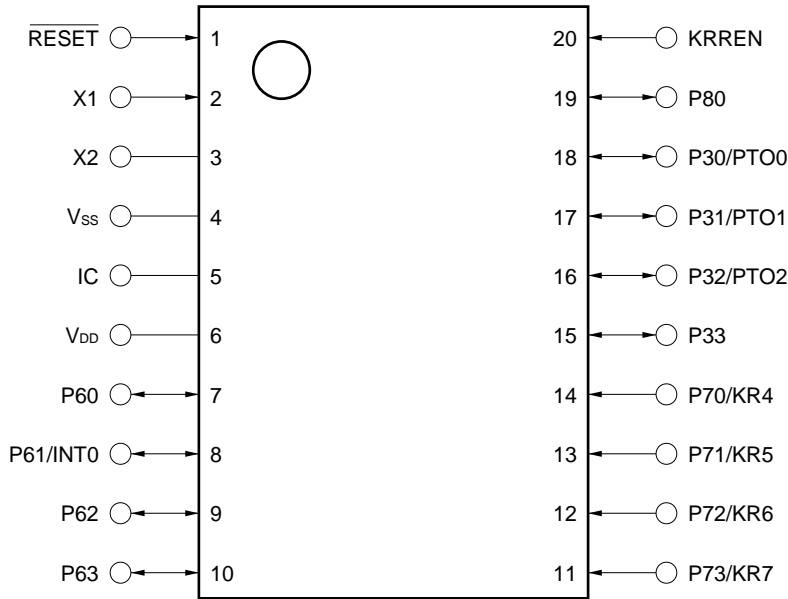

IC: Internally Connected (Connect directly to V_{DD})

Pin Identification

- IC : Internally Connected
- INT0 : External Vectored Interrupt
- KR4 to KR7 : Key Return 4 to 7
- KRREN : Key Return Reset Enable
- P30 to P33 : Port 3
- P60 to P63 : Port 6
- P70 to P73 : Port 7
- P80 : Port 8
- PTO0 to PTO2 : Programmable Timer Output 0 to 2
- RESET : Reset
- V_{DD} : Positive Power Supply
- V_{SS} : Ground
- X1, X2 : System Clock (Ceramic/Crystal)

2. BLOCK DIAGRAM

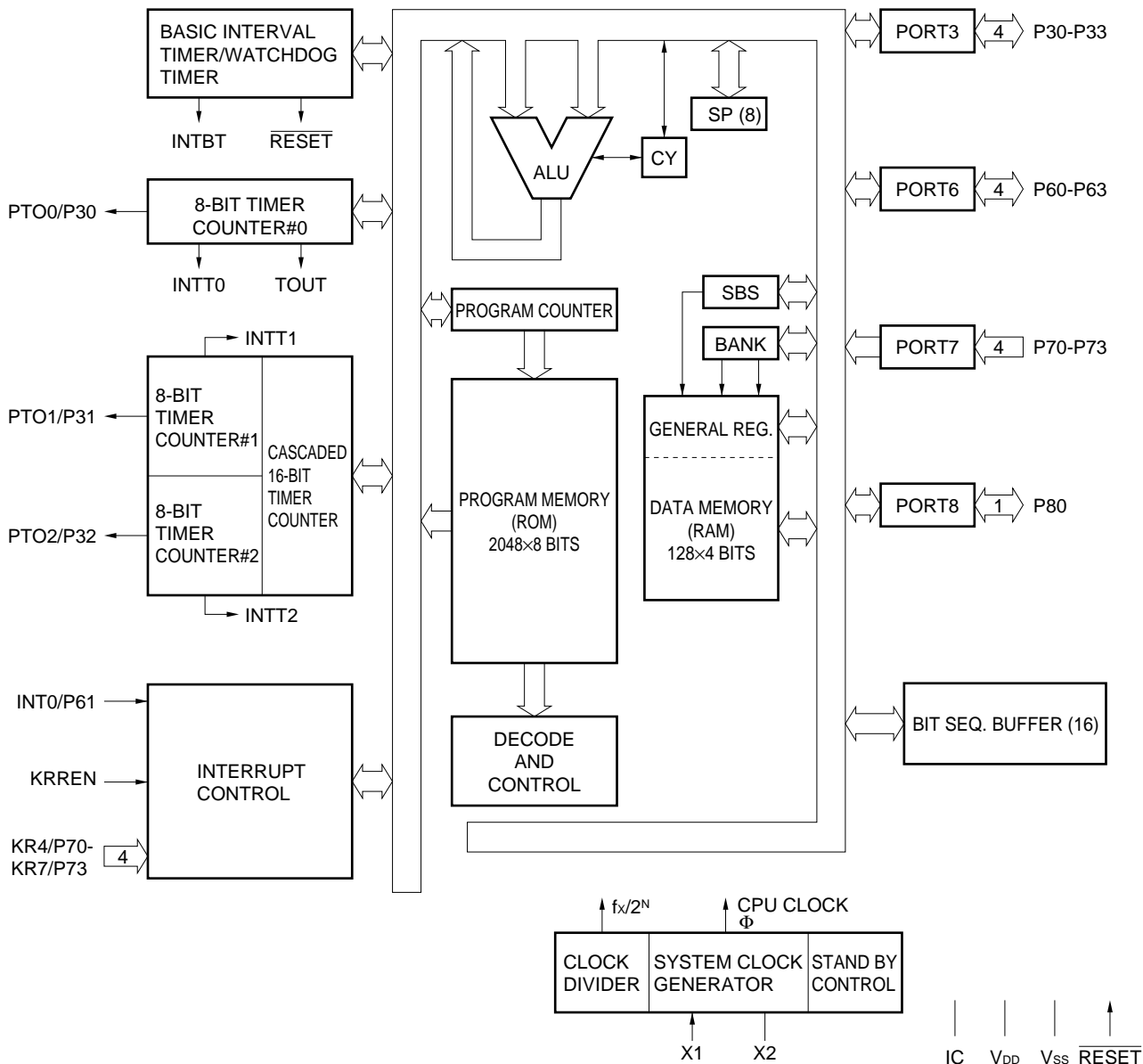

3. PIN FUNCTION

3.1 Port Pins

Pin Name	Input/Output	Alternate Function	Function	8-bit I/O	After Reset	I/O Circuit Type ^{Note}
P30	Input/Output	PTO0	Programmable 4-bit input/output port (PORT3). This port can be specified input/output bit-wise. On-chip pull-up resistor can be specified by software in 4-bit units.	-	Input	E-B
P31		PTO1				
P32		PTO2				
P33		-				
P60	Input/Output	-	Programmable 4-bit input/output port (PORT6). This port can be specified input/output bit-wise. On-chip pull-up resistor can be specified by software in 4-bit units. Noise eliminator can be selected on P61/INT0.	-	Input	Ⓕ-A
P61		INT0				
P62		-				
P63		-				
P70	Input	KR4	4-bit input port (PORT7). On-chip pull-up resistor can be specified bit-wise (mask option).	-	Input	Ⓑ-A
P71		KR5				
P72		KR6				
P73		KR7				
P80	Input/Output	-	1-bit input/output port (PORT8). On-chip pull-up resistor can be specified by software.	-	Input	Ⓕ-A

Note Circled characters indicate Schmitt trigger input.

3.2 Non-port Pins

Pin Name	Input/Output	Alternate Function	Function		After Reset	I/O Circuit Type ^{Note}
PTO0	Output	P30	Timer counter output		Input	E-B
PTO1		P31				
PTO2		P32				
INT0	Input	P61	Edge detection vectored interrupt input (detected edge is selectable) Noise eliminator selectable	Noise eliminator/asynchronous selectable	Input	Ⓕ-A
KR4 to KR7	Input	P70 to P73	Falling edge detection testable input		Input	Ⓑ-A
KRREN	Input	–	Key return reset enable. When KRREN = high level in STOP mode, reset signal is generated at falling edge of KRn.		Input	Ⓑ
X1	Input	–	System clock oscillation crystal/ceramic connection pin. If using an external clock, input to X1 and reverse input to X2.		–	–
X2	–					
$\overline{\text{RESET}}$	Input	–	System reset input (low-level active). Pull-up resistor can be incorporated on-chip (mask option).		–	Ⓑ-A
IC	–	–	Internally connected. Connect directly to V _{DD} .		–	–
V _{DD}	–	–	Positive power supply		–	–
V _{SS}	–	–	Ground potential		–	–

Note Circled characters indicate Schmitt trigger input.

3.3 Pin Input/Output Circuits

The μPD754202 pin input/output circuits are shown schematically.

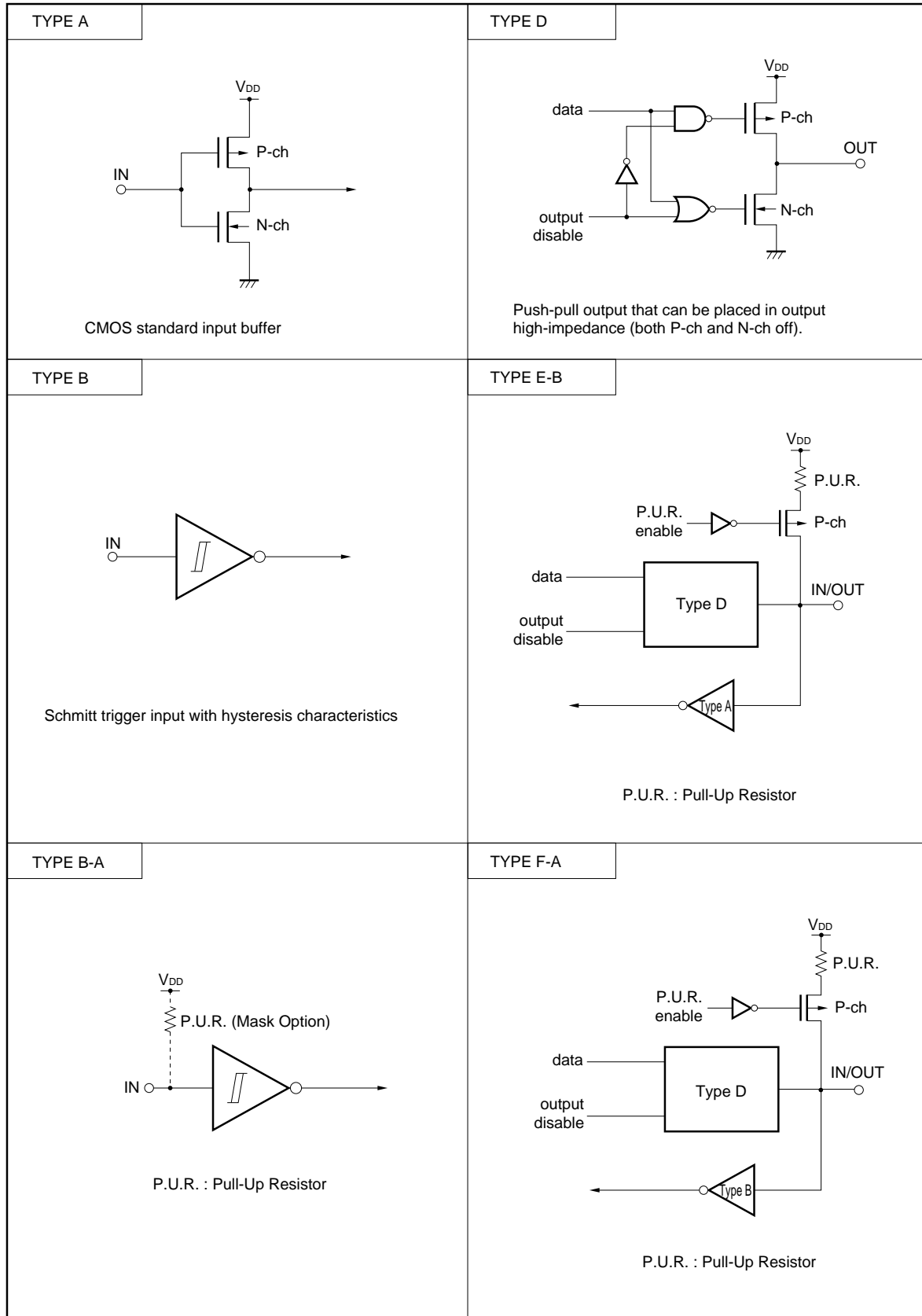

3.4 Recommended Connection of Unused Pins

Table 3-1. List of Recommended Connection of Unused Pins

Pin	Recommended Connecting Method
P30/PTO0	Input state : Independently connect to V_{SS} or V_{DD} via a resistor. Output state: Leave open.
P31/PTO1	
P32/PTO2	
P33	
P60	
P61/INT0	
P62	
P63	
P70/KR4	
P71/KR5	
P72/KR6	
P73/KR7	
P80	Input state : Independently connect to V_{SS} or V_{DD} via a resistor. Output state: Leave open.
KRREN	When this pin is connected to V_{DD} , internal reset signal is generated at the falling edge of the KR_n pin in the STOP mode. When this pin is connected to V_{SS} , internal reset signal is not generated even if the falling edge of KR_n pin is detected in the STOP mode.
IC	Connect directly to V_{DD} .

4. SWITCHING FUNCTION BETWEEN Mk I MODE AND Mk II MODE

4.1 Differences between Mk I Mode and Mk II Mode

The μPD754202 75XL CPU has the following two modes: Mk I and Mk II, either of which can be selected. The mode can be switched by bit 3 of the stack bank select register (SBS).

- Mk I mode : Instructions are compatible with the 75X Series. Can be used in the 75XL CPU with a ROM capacity of up to 16 Kbytes.
- Mk II mode: Incompatible with 75X Series. Can be used in all the 75XL CPU's including those products whose ROM capacity is more than 16 Kbytes.

Table 4-1. Differences between Mk I Mode and Mk II Mode

	Mk I mode	Mk II mode
Number of stack bytes for subroutine instructions	2 bytes	3 bytes
BRA !addr1 instruction CALLA !addr1 instruction	Not available	Available
CALL !addr instruction	3 machine cycles	4 machine cycles
CALLF !faddr instruction	2 machine cycles	3 machine cycles

Caution The Mk II mode supports a program area exceeding 16 Kbytes for the 75X and 75XL Series. Therefore, this mode is effective for enhancing software compatibility with products that have a program area of more than 16 Kbytes.

The number of stack bytes (usable area) during execution of subroutine call instructions increases by 1 byte per stack compared to the Mk I mode when the Mk II mode is selected.

However, when the CALL !addr and CALL !faddr instructions are used, the machine cycle becomes longer by 1 machine cycle. Therefore, if more emphasis is placed on RAM use efficiency and processing performance than on software compatibility, the Mk I mode should be used.

4.2 Setting Method of Stack Bank Select Register (SBS)

Switching between the Mk I mode and Mk II mode can be done by the SBS. Figure 4-1 shows the format. The SBS is set by a 4-bit memory manipulation instruction.

When using the Mk I mode, the SBS must be initialized to 1000B at the beginning of a program. When using the Mk II mode, it must be initialized to 0000B.

Figure 4-1. Stack Bank Select Register Format

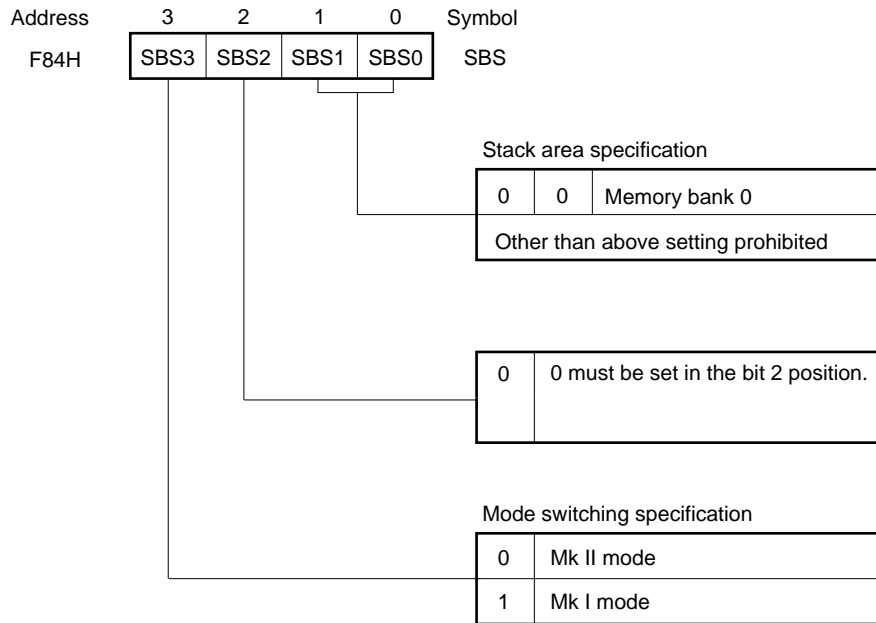

Caution Because SBS.3 is set to “1” after a $\overline{\text{RESET}}$ signal is generated, the CPU operates in the Mk I mode. When executing an instruction in the Mk II mode, set SBS.3 to “0” to select the Mk II mode.

5. MEMORY CONFIGURATION

- Program Memory (ROM): 2048 \times 8 bits (0000H-07FFH)
 - Addresses 0000H and 0001H
Vector table wherein the program start address and the values set for the RBE and MBE at the time a $\overline{\text{RESET}}$ signal is generated are written. Reset start is possible from any address.
 - Addresses 0002H to 000DH
Vector table wherein the program start address and values set for the RBE and MBE by the vectored interrupts are written. Interrupt service can start from any address.
 - Addresses 0020H to 007FH
Table area referenced by the GETI instruction^{Note}.

Note The GETI instruction realizes a 1-byte instruction on behalf of any 2-byte instruction, 3-byte instruction, or two 1-byte instructions. It is used to decrease the number of program steps.

- Data Memory (RAM)
 - Data area: 128 words \times 4 bits (000H-07FH)
 - Peripheral hardware area: 128 words \times 4 bits (F80H-FFFH)

Figure 5-1. Program Memory Map

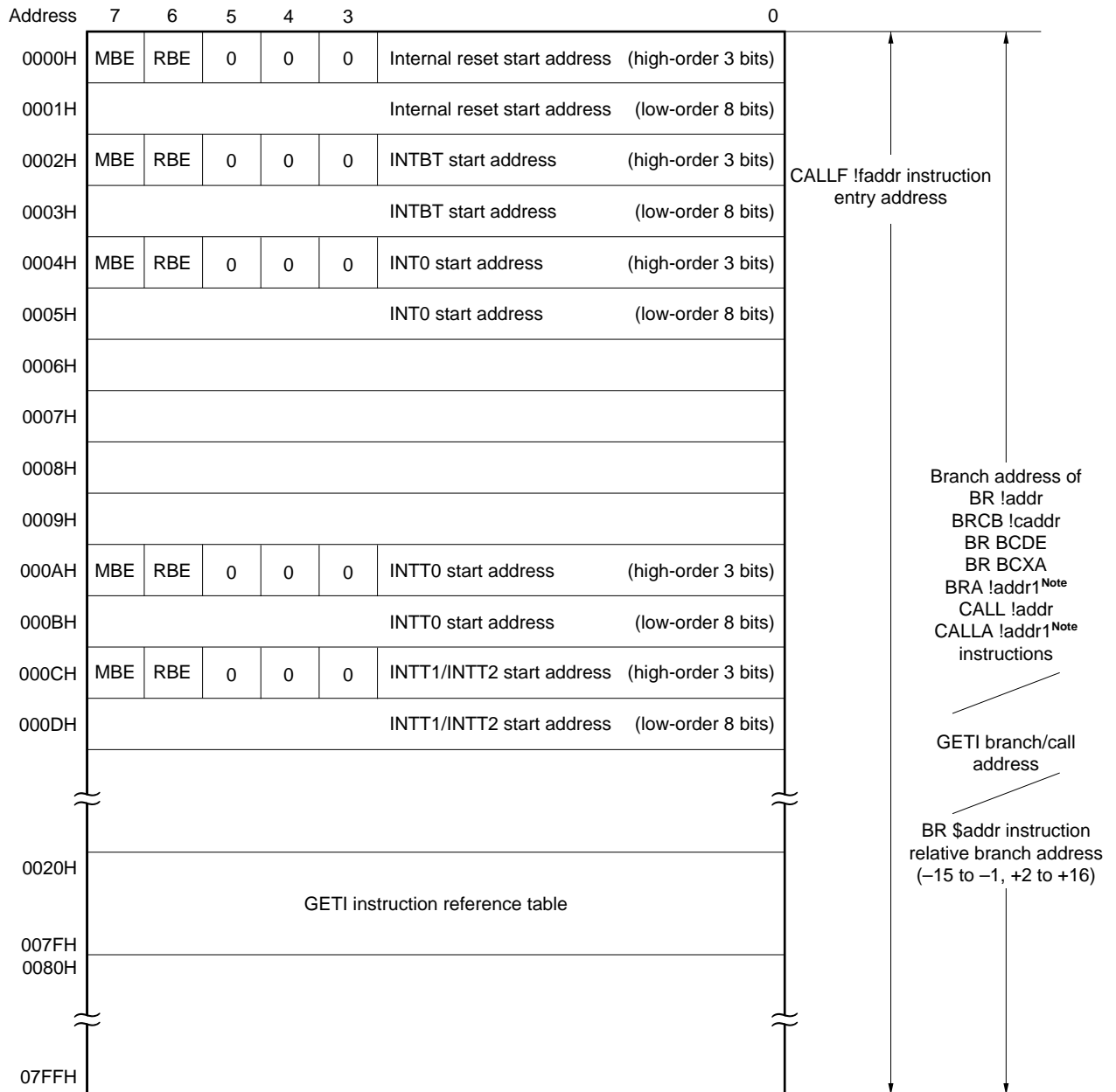

Note Can be used in Mk II mode only.

Remark In addition to the above, a branch can be made to an address with only the low-order 8 bits of the PC changed by means of a BR PCDE or BR PCXA instruction.

Figure 5-2. Data Memory Map

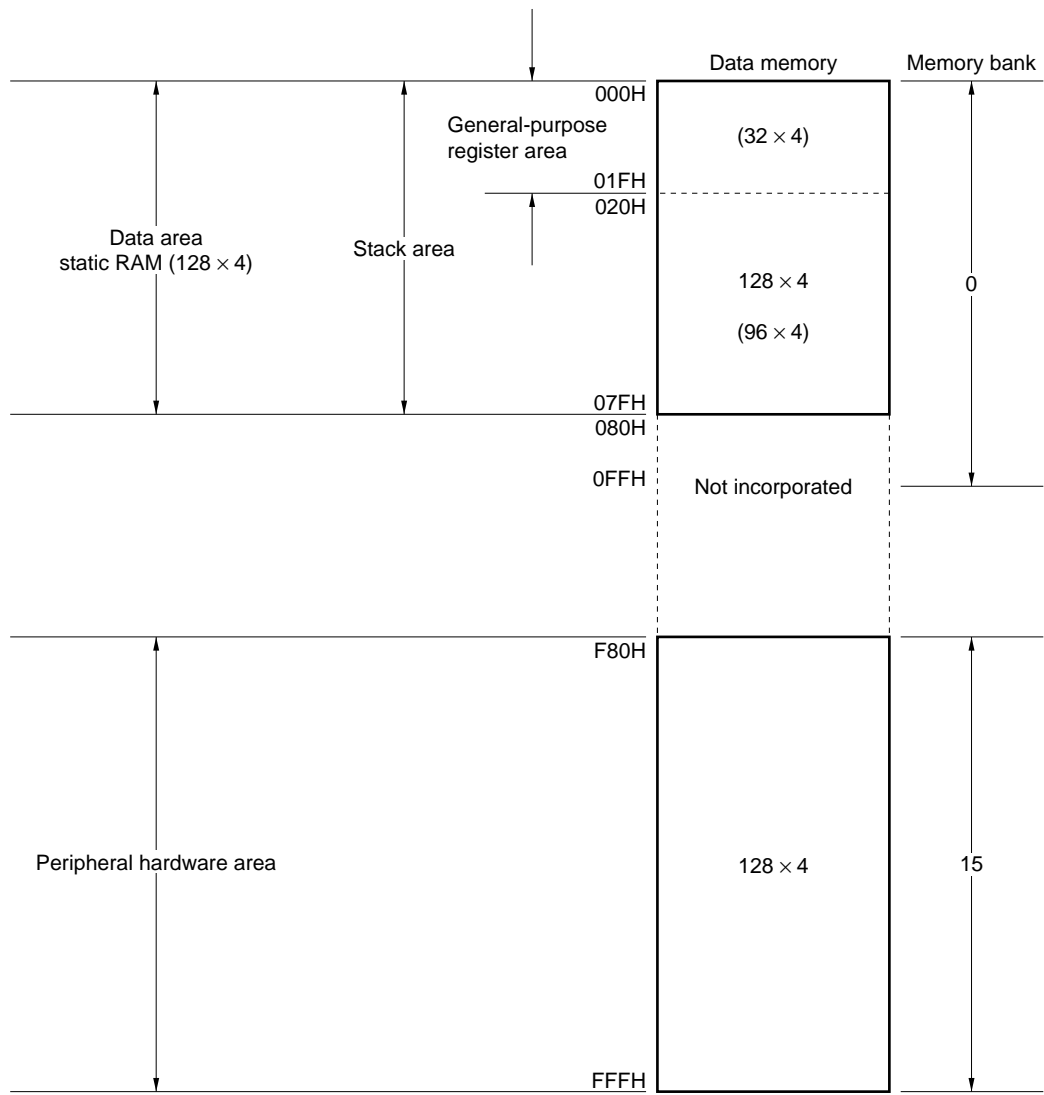

6. PERIPHERAL HARDWARE FUNCTION

6.1 Digital I/O Port

The following two types of I/O ports are provided.

• CMOS Input (PORT7)	: 4
• CMOS Input/Output (PORT3, 6, 8)	: 9
Total	13

Table 6-1. Types and Features of Digital Ports

Port Name	Function	Operation and Features	Remarks
PORT3	4-bit I/O	Can be set to input or output mode bit-wise.	Also used for PTO0 to PTO2 pins.
PORT6			Also used for INT0 pin.
PORT7	4-bit input	4-bit input only port On-chip pull-up resistor can be specified by mask option bit-wise.	Also used for KR4 to KR7 pins.
PORT8	1-bit I/O	Can be set to input or output mode bit-wise.	–

6.2 Clock Generator

The clock generator provides the clock signals to the CPU and peripheral hardware. Its configuration is shown in Figure 6-1.

The operation of the clock generator is set with the processor clock control register (PCC). The instruction execution time can be changed as follows.

- 0.95, 1.91, 3.81, 15.3 μs (system clock operating at 4.19 MHz)
- 0.67, 1.33, 2.67, 10.7 μs (system clock operating at 6.0 MHz)

Figure 6-1. Clock Generator Block Diagram

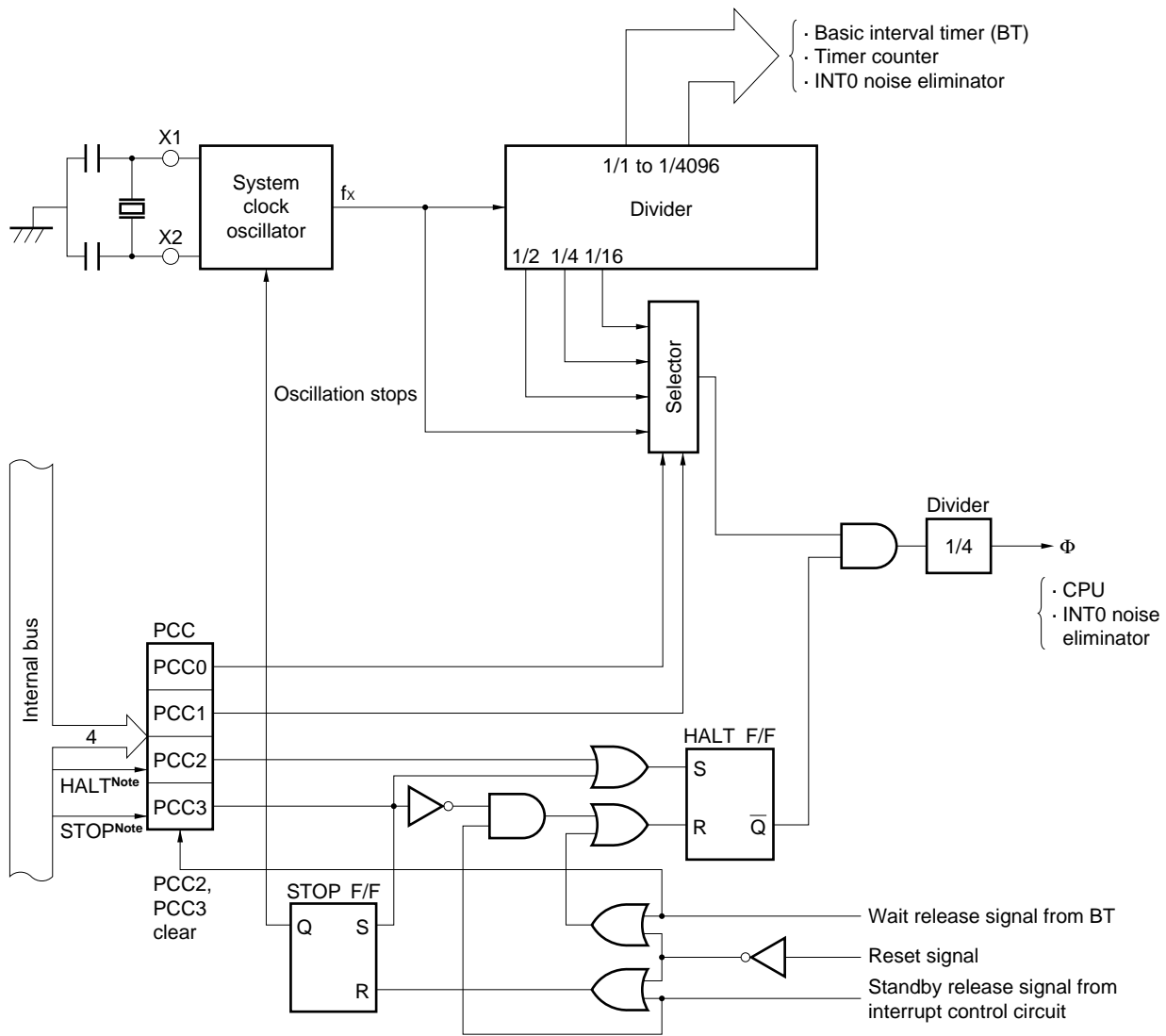

Note Instruction execution

- Remarks**
1. f_x : System clock frequency
 2. Φ = CPU clock
 3. PCC: Processor Clock Control Register
 4. One clock cycle (t_{cy}) of the CPU clock is equal to one machine cycle of the instruction.

6.3 Basic Interval Timer/Watchdog Timer

The basic interval timer/watchdog timer has the following functions.

- (a) Interval timer operation to generate a reference time interrupt
- (b) Watchdog timer operation to detect a runaway of program and reset the CPU
- (c) Selects and counts the wait time when the standby mode is released
- (d) Reads the contents of counting

Figure 6-2. Basic Interval Timer/Watchdog Timer Block Diagram

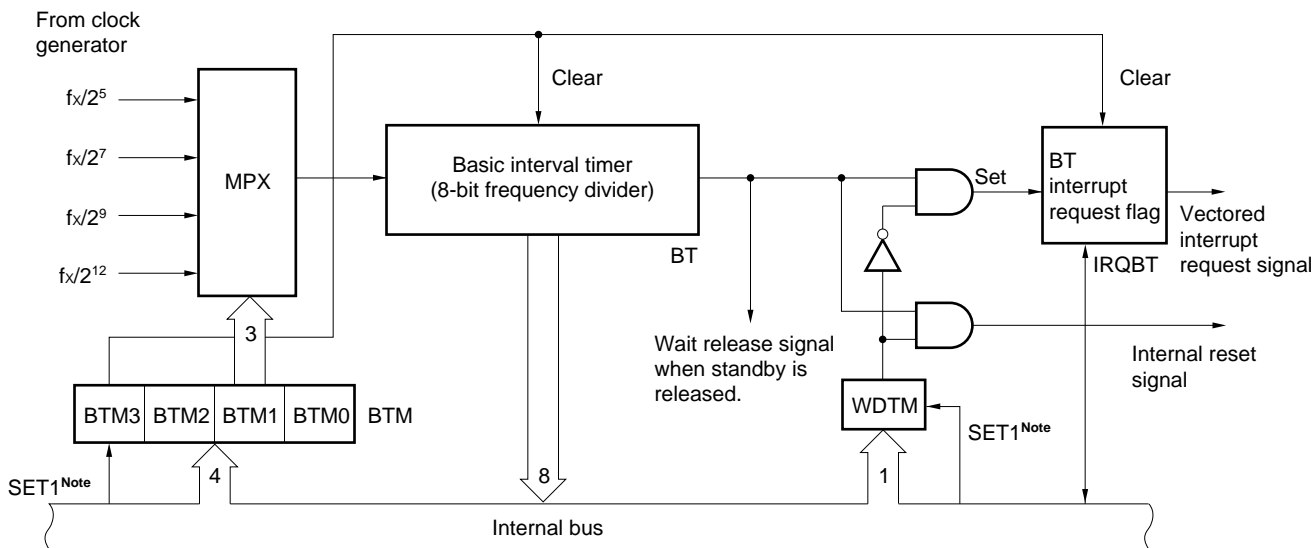

Note Instruction execution

6.4 Timer Counter

The μPD754202 incorporates three timer counters. Its configuration is shown in Figures 6-3, 6-4, and 6-5. The timer counter functions are shown below.

- (a) Programmable interval timer operation
- (b) Square wave output of any frequency to PTO0-PTO2 pins
- (c) Count value read function

The timer counter can operate in the following four modes as set by the mode register.

Table 6-2. Mode List

Mode \ Channel	Channel 0	Channel 1	Channel 2	TM11	TM10	TM21	TM20
8-bit timer counter mode	○	○	○	0	0	0	0
PWM pulse generator mode	×	×	○	0	0	0	1
16-bit timer counter mode	×	○		1	0	1	0
Carrier generator mode	×	○		0	0	1	1

Remark ○: Available
 ×: Not available

Figure 6-3. Timer Counter (Channel 0) Block Diagram

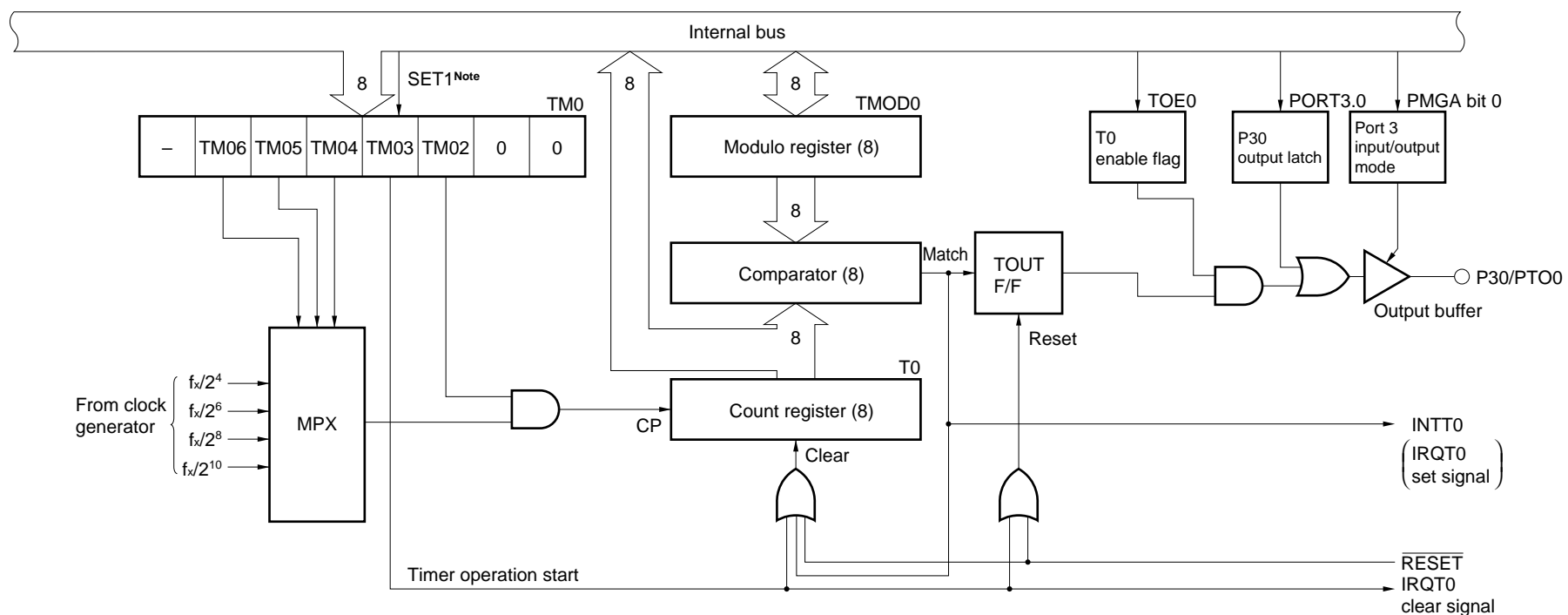

Note Instruction execution

Caution Always set bits 0 and 1 to 0 when setting data to TM0.

Figure 6-4. Timer Counter (Channel 1) Block Diagram

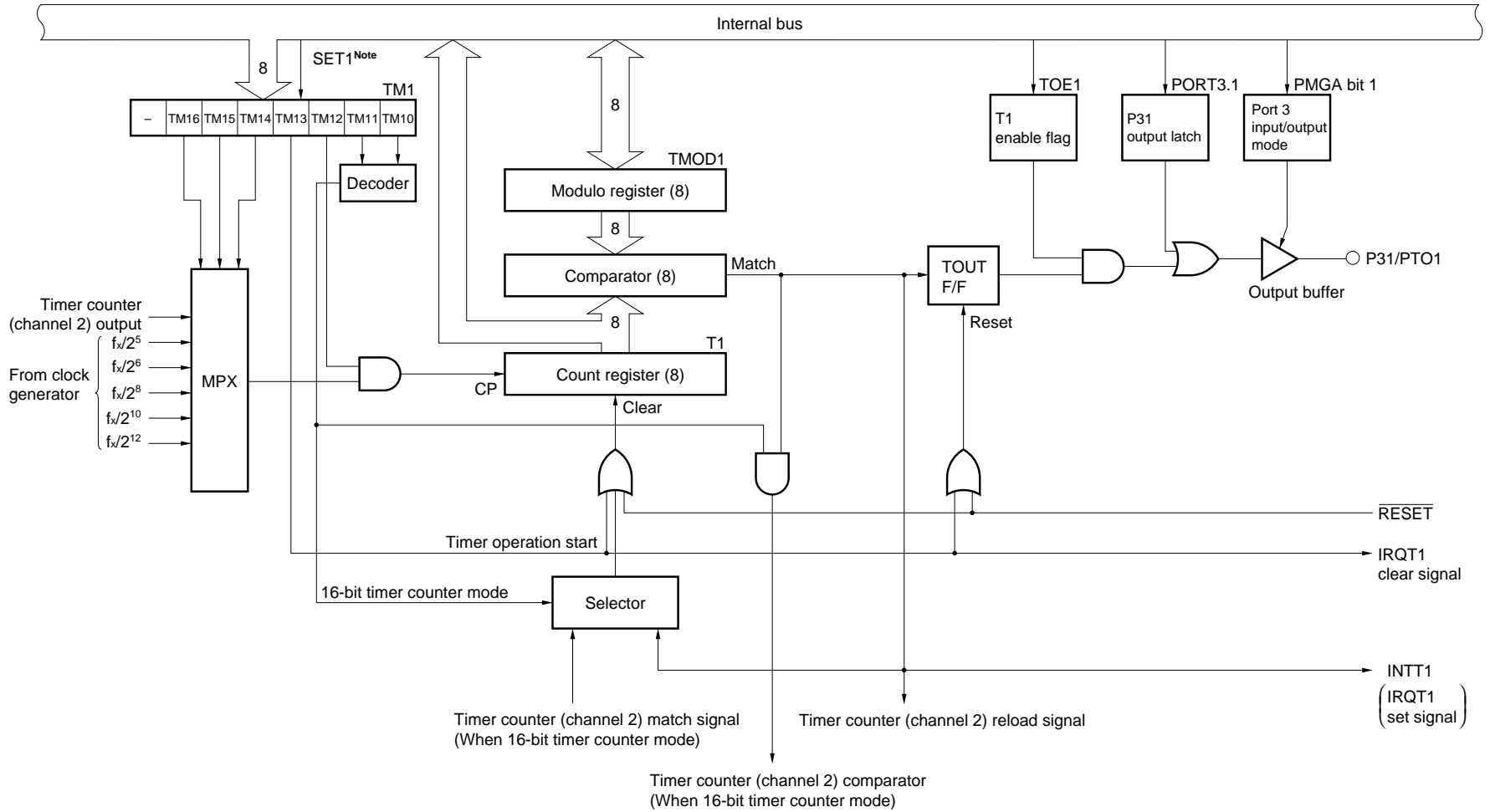

Note Instruction execution

Figure 6-5. Timer Counter (Channel 2) Block Diagram

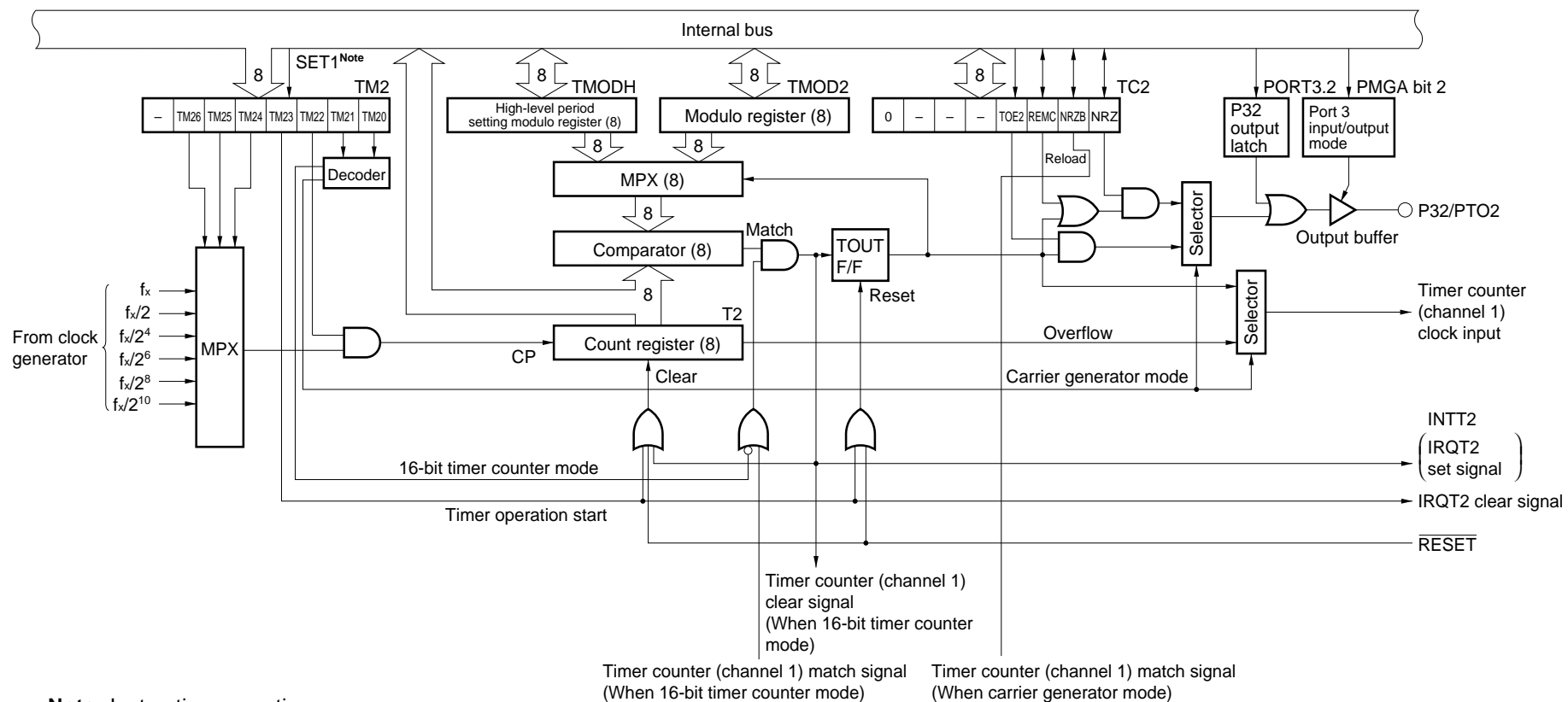

6.5 Bit Sequential Buffer 16 Bits

The bit sequential buffer (BSB) is a special data memory for bit manipulation and the bit manipulation can be easily performed by changing the address specification and bit specification in sequence, therefore it is useful when processing large data bit-wise.

Figure 6-6. Bit Sequential Buffer Format

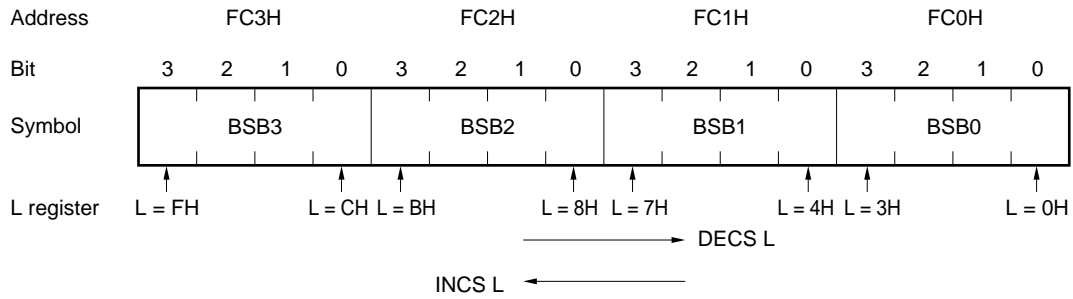

- Remarks 1.** In the pmem.@L addressing, the specified bit moves corresponding to the L register.
- 2.** In the pmem.@L addressing, the BSB can be manipulated regardless of MBE/MBS specification.

7. INTERRUPT FUNCTION AND TEST FUNCTION

The μ PD754202 is provided with five types of interrupt sources and one test source to enable a variety of applications.

The interrupt control circuit of the μ PD754202 has the following functions.

(1) Interrupt function

- Vectored interrupt function for hardware control, enabling/disabling the interrupt acknowledgement by the interrupt enable flag (IE $\times\times\times$) and interrupt master enable flag (IME).
- Can set any interrupt start address.
- Multiple interrupts wherein the order of priority can be specified by the interrupt priority select register (IPS).
- Test function of interrupt request flag (IRQ $\times\times\times$). An interrupt generated can be checked by software.
- Release the standby mode. The interrupt to be released can be selected by the interrupt enable flag.

(2) Test function

- Test request flag (IRQ2) generation can be checked by software.
- Release the standby mode. The test source to be released can be selected by the test enable flag.

Figure 7-1. Interrupt Control Circuit Block Diagram

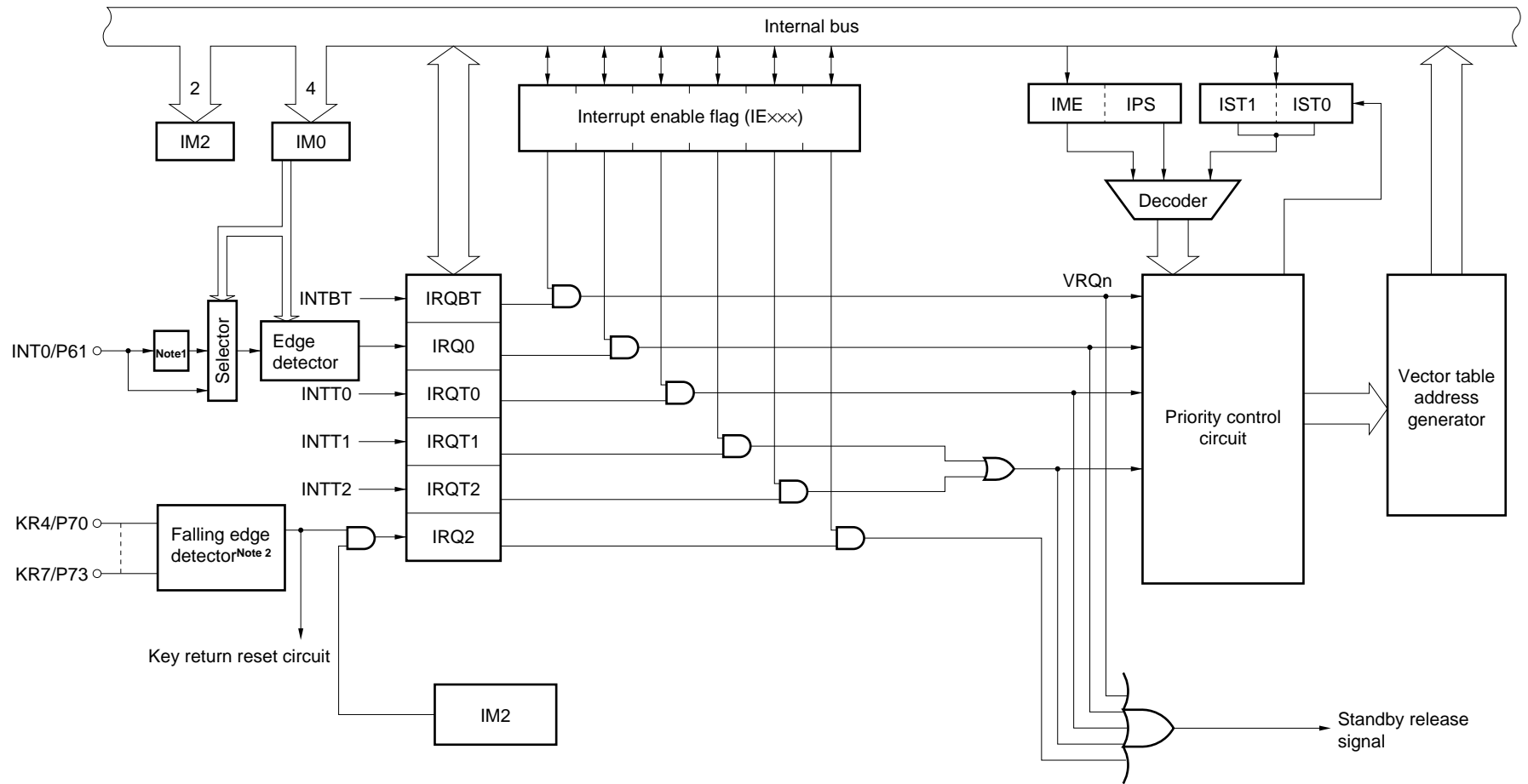

Notes 1. Noise eliminator (Standby release is disabled when noise eliminator is selected.)

2. The INT2 pin is not available. Interrupt request flag (IRQ2) is set at the KRn pin falling edge when IM20 = 1 and IM21 = 0.

8. STANDBY FUNCTION

In order to reduce power dissipation while a program is in standby mode, two types of standby modes (STOP mode and HALT mode) are provided for the μPD754202.

Table 8-1. Operation Status in Standby Mode

Item		Mode	STOP mode	HALT mode
Set instruction			STOP instruction	HALT instruction
Operation status	Clock generator		Operation stops.	Only the CPU clock Φ halts (oscillation continues).
	Basic interval timer/ watchdog timer		Operation stops.	Operable (BT mode : The IRQBT is set in the reference time interval. WT mode: Reset signal generation by BT overflow.)
	Timer counter		Operation stops.	Operable.
	External interrupt		The INT0 is not operable ^{Note} . The INT2 is operable at the falling edge of KRn.	
	CPU		Operation stops.	
Release signal			<ul style="list-style-type: none"> • Reset signal • Interrupt request signal sent from interrupt enabled hardware • System reset signal (key return reset) generated by KRn falling edge when KRREN pin = 1. 	<ul style="list-style-type: none"> • Reset signal • Interrupt request signal sent from interrupt enabled hardware

Note Can operate only when the noise eliminator is not used (IM02 = 1) by bit 2 of the edge detection mode register (IM0).

9. RESET FUNCTION

9.1 Configuration and Operation Status of Reset Function

There are three kinds of reset input: the external reset signal ($\overline{\text{RESET}}$), the reset signal sent from the basic interval/watchdog timer, and the reset signal generated by a falling edge signal from KRn in the STOP mode. When any of these reset signals is input, an internal reset signal is generated. The configuration is shown in Figure 9-1.

Figure 9-1. Configuration of Reset Function

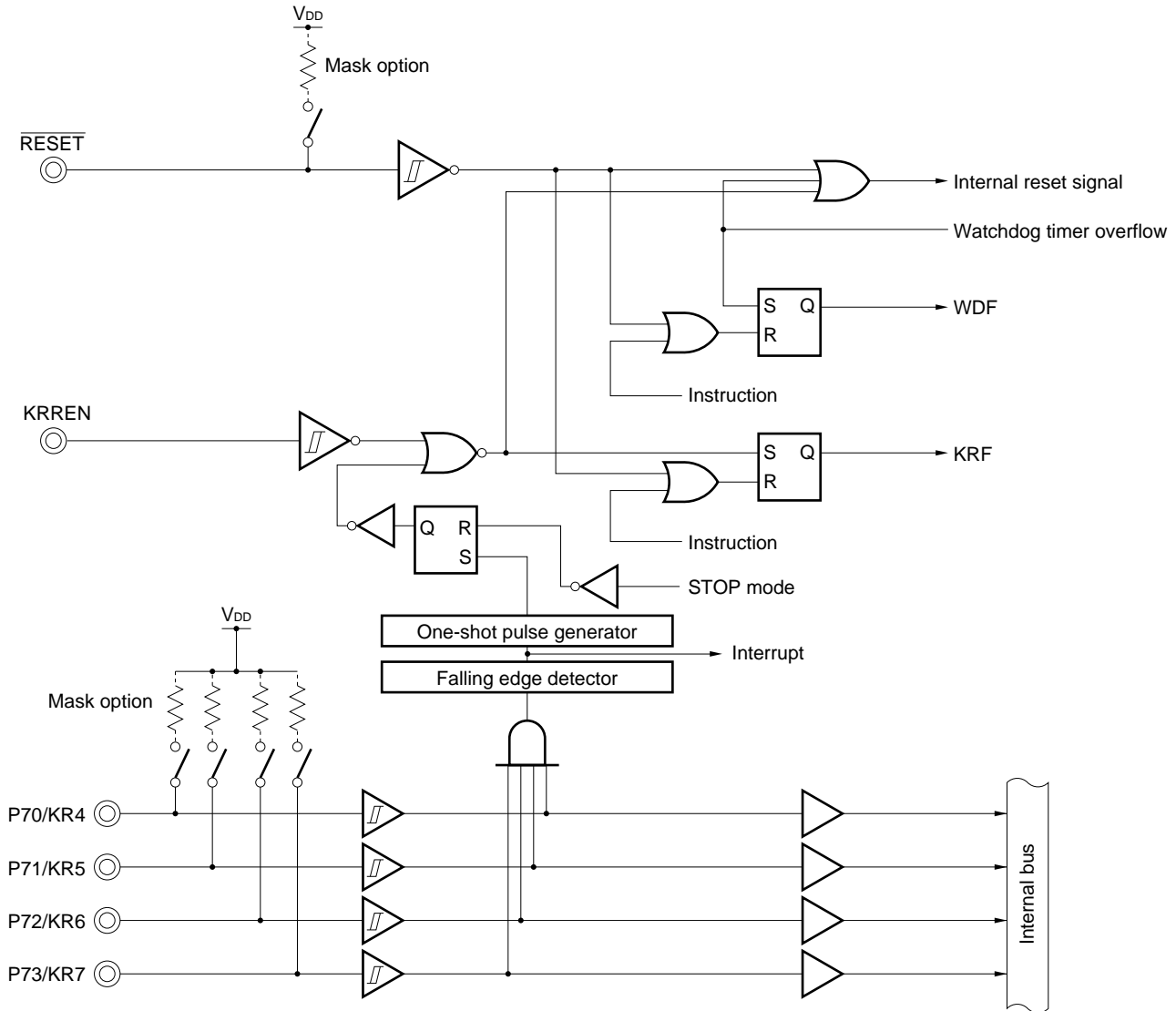

The $\overline{\text{RESET}}$ signal generation initializes each hardware as listed in Table 9-1. Figure 9-2 shows the timing chart of the reset operation.

Figure 9-2. Reset Operation by $\overline{\text{RESET}}$ Signal Generation

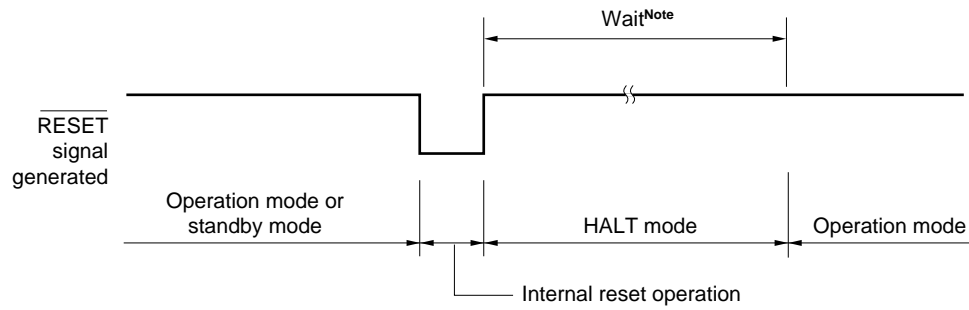

Note The following 2 time modes can be specified with mask option.
 $2^{17}/f_x$ (21.8 ms: at 6.0-MHz operation, 31.3 ms: at 4.19-MHz operation)
 $2^{15}/f_x$ (5.46 ms: at 6.0-MHz operation, 7.81 ms: at 4.19-MHz operation)

Table 9-1. Hardware Status After Reset (1/3)

Hardware		$\overline{\text{RESET}}$ signal generation in the standby mode	$\overline{\text{RESET}}$ signal generation in operation
Program counter (PC)		Sets the low-order 3 bits of program memory's address 0000H to the PC10-PC8 and the contents of address 0001H to the PC7-PC0.	Sets the low-order 3 bits of program memory's address 0000H to the PC10-PC8 and the contents of address 0001H to the PC7-PC0.
PSW	Carry flag (CY)	Held	Undefined
	Skip flag (SK0-SK2)	0	0
	Interrupt status flag (IST0, IST1)	0	0
	Bank enable flag (MBE, RBE)	Sets the bit 6 of program memory's address 0000H to the RBE and bit 7 to the MBE.	Sets the bit 6 of program memory's address 0000H to the RBE and bit 7 to the MBE.
Stack pointer (SP)		Undefined	Undefined
Stack bank select register (SBS)		1000B	1000B
Data memory (RAM)		Held	Undefined
General-purpose register (X, A, H, L, D, E, B, C)		Held	Undefined
Bank select register (MBS, RBS)		0, 0	0, 0
Basic interval	Counter (BT)	Undefined	Undefined
timer/watchdog	Mode register (BTM)	0	0
timer	Watchdog timer enable flag (WDTM)	0	0
Timer counter (T0)	Counter (T0)	0	0
	Modulo register (TMOD0)	FFH	FFH
	Mode register (TM0)	0	0
	TOE0, TOUT F/F	0, 0	0, 0
Timer counter (T1)	Counter (T1)	0	0
	Modulo register (TMOD1)	FFH	FFH
	Mode register (TM1)	0	0
	TOE1, TOUT F/F	0, 0	0, 0
Timer counter (T2)	Counter (T2)	0	0
	Modulo register (TMOD2)	FFH	FFH
	High-level period setting modulo register (TMOD2H)	FFH	FFH
	Mode register (TM2)	0	0
	TOE2, TOUT F/F	0, 0	0, 0
	REMC, NRZ, NRZB	0, 0, 0	0, 0, 0

Table 9-1. Hardware Status After Reset (2/3)

Hardware		$\overline{\text{RESET}}$ signal generation in the standby mode	$\overline{\text{RESET}}$ signal generation in operation
Clock generator	Processor clock control register (PCC)	0	0
Interrupt function	Interrupt request flag (IRQ _{xxx})	Reset (0)	Reset (0)
	Interrupt enable flag (IE _{xxx})	0	0
	Interrupt master enable flag (IME)	0	0
	Interrupt priority selection register (IPS)	0	0
	INT0, 2 mode registers (IM0, IM2)	0, 0	0, 0
Digital port	Output buffer	Off	Off
	Output latch	Cleared (0)	Cleared (0)
	I/O mode registers (PMGA, PMGC)	0	0
	Pull-up resistor setting register (POGA, POGB)	0	0
Bit sequential buffer (BSB0-BSB3)		Held	Undefined

Table 9-1. Hardware Status After Reset (3/3)

Hardware	$\overline{\text{RESET}}$ signal generation by key return reset	$\overline{\text{RESET}}$ signal generation in the standby mode	$\overline{\text{RESET}}$ signal generation by WDT during operation	$\overline{\text{RESET}}$ signal generation during operation
Watchdog flag (WDF)	Hold the previous status	0	1	0
Key return flag (KRF)	1	0	Hold the previous status	0

9.2 Watchdog Flag (WDF), Key Return Flag (KRF)

The WDF is set by a watchdog timer overflow signal, and the KRF is set by a reset signal generated by the KRn pins. As a result, by checking the contents of WDF and KRF, it is possible to know what kind of reset signal is generated.

As the WDF and KRF are cleared only by external signal or instruction execution, if once these flags are set, they are not cleared until an external signal is generated or a clear instruction is executed. Check and clear the contents of WDF and KRF after reset start operation by executing SKTCLR instruction and so on.

Table 9-2 lists the contents of WDF and KRF corresponding to each signal. Figure 9-3 shows the WDF operation in generating each signal, and Figure 9-4 shows the KRF operation in generating each signal.

Table 9-2. WDF and KRF Contents Correspond to Each Signal

Hardware	External $\overline{\text{RESET}}$ signal generation	Reset signal generation by watchdog timer overflow	Reset signal generation by the KRn input	WDF clear instruction execution	KRF clear instruction execution
Watchdog flag (WDF)	0	1	Hold	0	Hold
Key return flag (KRF)	0	Hold	1	Hold	0

Figure 9-3. WDF Operation in Generating Each Signal

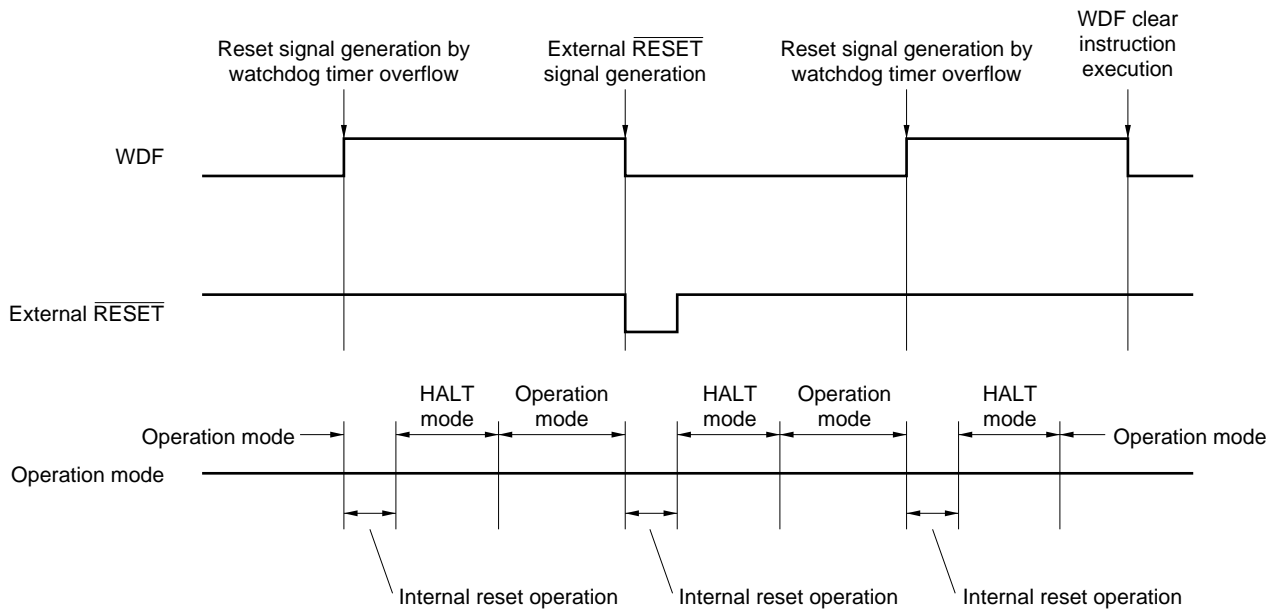
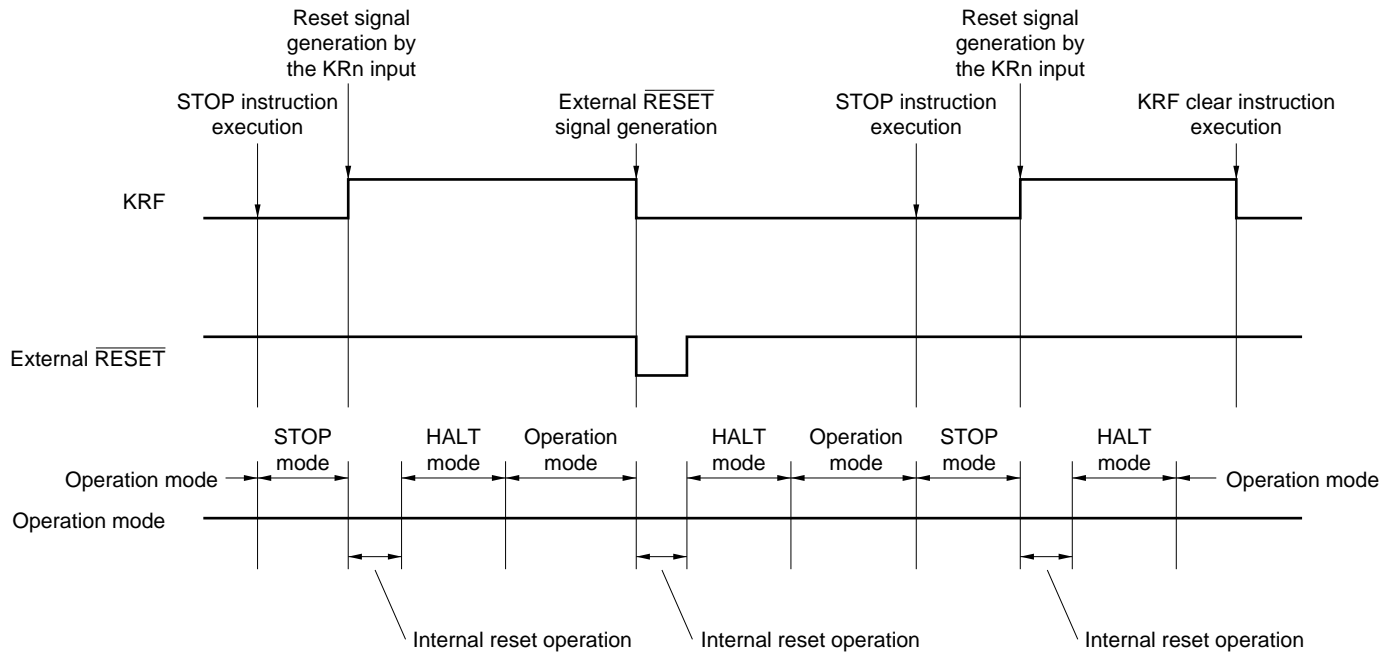

Figure 9-4. KRF Operation in Generating Each Signal



10. MASK OPTION

The μ PD754202 has the following mask options:

- Mask option of P70/KR4 through P73/KR7
Pull-up resistors can be connected to these pins.
 - (1) No pull-up resistor connection
 - (2) Connection of a 30-k Ω (typ.) pull-up resistor in 1-bit units.
 - (3) Connection of a 100-k Ω (typ.) pull-up resistor in 1-bit units.

- Mask option of $\overline{\text{RESET}}$ pin
Pull-up resistors can be connected to these pins.
 - (1) No pull-up resistor connection
 - (2) Connection of a 100-k Ω (typ.) pull-up resistor.

- Standby function mask option
The wait time after $\overline{\text{RESET}}$ signal can be selected.
 - (1) $2^{17}/f_x$ (21.8 ms: $f_x = 6.0\text{-MHz}$ operation, 31.3 ms: $f_x = 4.19\text{-MHz}$ operation)
 - (2) $2^{15}/f_x$ (5.46 ms: $f_x = 6.0\text{-MHz}$ operation, 7.81 ms: $f_x = 4.19\text{-MHz}$ operation)

11. INSTRUCTION SETS

(1) Expression formats and description methods of operands

The operand is described in the operand column of each instruction in accordance with the description method for the operand expression format of the instruction. For details, refer to “**RA75X ASSEMBLER PACKAGE USERS’ MANUAL — LANGUAGE (EEU-1363)**”. If there are several elements, one of them is selected. Capital letters and the + and – symbols are key words and are described as they are.

For immediate data, appropriate numbers and labels are described.

Instead of the labels such as mem, fmem, pmem, and bit, the symbols of the register flags can be described.

However, there are restrictions in the labels that can be described for fmem and pmem. For details, see μPD754202 User’s Manual (U11132E).

Expression format	Description method
reg	X, A, B, C, D, E, H, L
reg1	X, B, C, D, E, H, L
rp	XA, BC, DE, HL
rp1	BC, DE, HL
rp2	BC, DE
rp'	XA, BC, DE, HL, XA', BC', DE', HL'
rp'1	BC, DE, HL, XA', BC', DE', HL'
rpa	HL, HL+, HL–, DE, DL
rpa1	DE, DL
n4	4-bit immediate data or label
n8	8-bit immediate data or label
mem	8-bit immediate data or label ^{Note}
bit	2-bit immediate data or label
fmem	FB0H-FBFH, FF0H-FFFH immediate data or label
pmem	FC0H-FFFH immediate data or label
addr	0000H-07FFH immediate data or label
addr1(only in Mk II mode)	0000H-07FFH immediate data or label
caddr	12-bit immediate data or label
faddr	11-bit immediate data or label
taddr	20H-7FH immediate data (where bit0 = 0) or label
PORTn	PORT3, 6, 7, 8
IExxx	IEBT, IET0-IET2, IE0, IE2
RBn	RB0-RB3
MBn	MB0, MB15

Note mem can be only used for even address in 8-bit data processing.

(2) Legend in explanation of operation

A	: A register; 4-bit accumulator
B	: B register
C	: C register
D	: D register
E	: E register
H	: H register
L	: L register
X	: X register
XA	: XA register pair; 8-bit accumulator
BC	: BC register pair
DE	: DE register pair
HL	: HL register pair
XA'	: XA' extended register pair
BC'	: BC' extended register pair
DE'	: DE' extended register pair
HL'	: HL' extended register pair
PC	: Program counter
SP	: Stack pointer
CY	: Carry flag; bit accumulator
PSW	: Program status word
MBE	: Memory bank enable flag
RBE	: Register bank enable flag
PORT _n	: Port n (n = 3, 6, 7, 8)
IME	: Interrupt master enable flag
IPS	: Interrupt priority selection register
IE _{xxx}	: Interrupt enable flag
RBS	: Register bank selection register
MBS	: Memory bank selection register
PCC	: Processor clock control register
.	: Separation between address and bit
(xx)	: The contents addressed by xx
xxH	: Hexadecimal data

(3) Explanation of symbols under addressing area column

*1	MB = MBE•MBS (MBS = 0, 15)	
*2	MB = 0	
*3	MBE = 0 : MB = 0 (000H-07FH) MB = 15 (F80H-FFFH) MBE = 1 : MB = MBS (MBS = 0, 15)	
*4	MB = 15, fmem = FB0H-FBFH, FF0H-FFFH	
*5	MB = 15, pmem = FC0H-FFFH	
*6	addr = 0000H-07FFH	
*7	addr = (Current PC) – 15 to (Current PC) – 1 (Current PC) + 2 to (Current PC) + 16 addr1 = (Current PC) – 15 to (Current PC) – 1 (Current PC) + 2 to (Current PC) + 16	
*8	caddr = 0000H-07FFH	
*9	faddr = 0000H-07FFH	
*10	taddr = 0020H-007FH	
*11	addr1 = 0000H-07FFH	

- Remarks**
1. MB indicates memory bank that can be accessed.
 2. In *2, MB = 0 independently of how MBE and MBS are set.
 3. In *4 and *5, MB = 15 independently of how MBE and MBS are set.
 4. *6 to *11 indicate the areas that can be addressed.

(4) Explanation of number of machine cycles column

S denotes the number of machine cycles required by skip operation when a skip instruction is executed. The value of S varies as follows.

- When no skip is made: S = 0
- When the skipped instruction is a 1- or 2-byte instruction: S = 1
- When the skipped instruction is a 3-byte instruction^{Note}: S = 2

Note 3-byte instruction: BR !addr, BRA !addr1, CALL !addr, or CALLA !addr1 instruction

Caution The GETI instruction is skipped in one machine cycle.

One machine cycle is equal to one cycle of the CPU clock (= tcy); time can be selected from among four types by setting PCC.

Instruction group	Mnemonic	Operand	Number of bytes	Number of machine cycles	Operation	Addressing area	Skip condition
Transfer instruction	MOV	A, #n4	1	1	$A \leftarrow n4$		String effect A
		reg1, #n4	2	2	$reg1 \leftarrow n4$		
		XA, #n8	2	2	$XA \leftarrow n8$		String effect A
		HL, #n8	2	2	$HL \leftarrow n8$		String effect B
		rp2, #n8	2	2	$rp2 \leftarrow n8$		
		A, @HL	1	1	$A \leftarrow (HL)$	*1	
		A, @HL+	1	2+S	$A \leftarrow (HL)$, then $L \leftarrow L+1$	*1	L = 0
		A, @HL-	1	2+S	$A \leftarrow (HL)$, then $L \leftarrow L-1$	*1	L = FH
		A, @rpa1	1	1	$A \leftarrow (rpa1)$	*2	
		XA, @HL	2	2	$XA \leftarrow (HL)$	*1	
		@HL, A	1	1	$(HL) \leftarrow A$	*1	
		@HL, XA	2	2	$(HL) \leftarrow XA$	*1	
		A, mem	2	2	$A \leftarrow (mem)$	*3	
		XA, mem	2	2	$XA \leftarrow (mem)$	*3	
		mem, A	2	2	$(mem) \leftarrow A$	*3	
		mem, XA	2	2	$(mem) \leftarrow XA$	*3	
		A, reg	2	2	$A \leftarrow reg$		
		XA, rp'	2	2	$XA \leftarrow rp'$		
		reg1, A	2	2	$reg1 \leftarrow A$		
		rp'1, XA	2	2	$rp'1 \leftarrow XA$		
	XCH	A, @HL	1	1	$A \leftrightarrow (HL)$	*1	
		A, @HL+	1	2+S	$A \leftrightarrow (HL)$, then $L \leftarrow L+1$	*1	L = 0
		A, @HL-	1	2+S	$A \leftrightarrow (HL)$, then $L \leftarrow L-1$	*1	L = FH
		A, @rpa1	1	1	$A \leftrightarrow (rpa1)$	*2	
		XA, @HL	2	2	$XA \leftrightarrow (HL)$	*1	
		A, mem	2	2	$A \leftrightarrow (mem)$	*3	
		XA, mem	2	2	$XA \leftrightarrow (mem)$	*3	
		A, reg1	1	1	$A \leftrightarrow reg1$		
XA, rp'		2	2	$XA \leftrightarrow rp'$			
Table reference instructions	MOVT	XA, @PCDE	1	3	$XA \leftarrow (PC_{10-8}+DE)_{ROM}$		
		XA, @PCXA	1	3	$XA \leftarrow (PC_{10-8}+XA)_{ROM}$		
		XA, @BCDE	1	3	$XA \leftarrow (BCDE)_{ROM}$ ^{Note}	*6	
		XA, @BCXA	1	3	$XA \leftarrow (BCXA)_{ROM}$ ^{Note}	*6	

Note "0" must be set to the B register.

Instruction group	Mnemonic	Operand	Number of bytes	Number of machine cycles	Operation	Addressing area	Skip condition
Bit transfer instructions	MOV1	CY, fmem.bit	2	2	$CY \leftarrow (fmem.bit)$	*4	
		CY, pmem.@L	2	2	$CY \leftarrow (pmem_{7-2+L_{3-2}.bit(L_{1-0}))$	*5	
		CY, @H+mem.bit	2	2	$CY \leftarrow (H+mem_{3-0}.bit)$	*1	
		fmem.bit, CY	2	2	$(fmem.bit) \leftarrow CY$	*4	
		pmem.@L, CY	2	2	$(pmem_{7-2+L_{3-2}.bit(L_{1-0})) \leftarrow CY$	*5	
		@H+mem.bit, CY	2	2	$(H+mem_{3-0}.bit) \leftarrow CY$	*1	
Operation instructions	ADDS	A, #n4	1	1+S	$A \leftarrow A+n4$		carry
		XA, #n8	2	2+S	$XA \leftarrow XA+n8$		carry
		A, @HL	1	1+S	$A \leftarrow A+(HL)$	*1	carry
		XA, rp'	2	2+S	$XA \leftarrow XA+rp'$		carry
		rp'1, XA	2	2+S	$rp'1 \leftarrow rp'1+XA$		carry
	ADDC	A, @HL	1	1	$A, CY \leftarrow A+(HL)+CY$	*1	
		XA, rp'	2	2	$XA, CY \leftarrow XA+rp'+CY$		
		rp'1, XA	2	2	$rp'1, CY \leftarrow rp'1+XA+CY$		
	SUBS	A, @HL	1	1+S	$A \leftarrow A-(HL)$	*1	borrow
		XA, rp'	2	2+S	$XA \leftarrow XA-rp'$		borrow
		rp'1, XA	2	2+S	$rp'1 \leftarrow rp'1-XA$		borrow
	SUBC	A, @HL	1	1	$A, CY \leftarrow A-(HL)-CY$	*1	
		XA, rp'	2	2	$XA, CY \leftarrow XA-rp'-CY$		
		rp'1, XA	2	2	$rp'1, CY \leftarrow rp'1-XA-CY$		
	AND	A, #n4	2	2	$A \leftarrow A \wedge n4$		
		A, @HL	1	1	$A \leftarrow A \wedge (HL)$	*1	
		XA, rp'	2	2	$XA \leftarrow XA \wedge rp'$		
		rp'1, XA	2	2	$rp'1 \leftarrow rp'1 \wedge XA$		
	OR	A, #n4	2	2	$A \leftarrow A \vee n4$		
		A, @HL	1	1	$A \leftarrow A \vee (HL)$	*1	
		XA, rp'	2	2	$XA \leftarrow XA \vee rp'$		
		rp'1, XA	2	2	$rp'1 \leftarrow rp'1 \vee XA$		
	XOR	A, #n4	2	2	$A \leftarrow A \vee n4$		
		A, @HL	1	1	$A \leftarrow A \vee (HL)$	*1	
XA, rp'		2	2	$XA \leftarrow XA \vee rp'$			
rp'1, XA		2	2	$rp'1 \leftarrow rp'1 \vee XA$			
Accumulator manipulation instructions	RORC	A	1	1	$CY \leftarrow A_0, A_3 \leftarrow CY, A_{n-1} \leftarrow A_n$		
	NOT	A	2	2	$A \leftarrow \bar{A}$		

Instruction group	Mnemonic	Operand	Number of bytes	Number of machine cycles	Operation	Addressing area	Skip condition
Increment and Decrement instructions	INCS	reg	1	1+S	reg ← reg+1		reg = 0
		rp1	1	1+S	rp1 ← rp1+1		rp1 = 00H
		@HL	2	2+S	(HL) ← (HL)+1	*1	(HL) = 0
		mem	2	2+S	(mem) ← (mem)+1	*3	(mem) = 0
	DECS	reg	1	1+S	reg ← reg-1		reg = FH
		rp'	2	2+S	rp' ← rp'-1		rp' = FFH
Comparison instruction	SKE	reg, #n4	2	2+S	Skip if reg = n4		reg = n4
		@HL, #n4	1	2+S	Skip if (HL) = n4	*1	(HL) = n4
		A, @HL	2	1+S	Skip if A = (HL)	*1	A = (HL)
		XA, @HL	2	2+S	Skip if XA = (HL)	*1	XA = (HL)
		A, reg	2	2+S	Skip if A = reg		A = reg
		XA, rp'	2	2+S	Skip if XA = rp'		XA = rp'
Carry flag manipulation instruction	SET1	CY	1	1	CY ← 1		
	CLR1	CY	1	1	CY ← 0		
	SKT	CY	1	1+S	Skip if CY = 1		CY = 1
	NOT1	CY	1	1	CY ← \overline{CY}		
Memory bit manipulation instructions	SET1	mem.bit	2	2	(mem.bit) ← 1	*3	
		fmem.bit	2	2	(fmem.bit) ← 1	*4	
		pmem.@L	2	2	(pmem ₇₋₂ +L ₃₋₂ .bit(L ₁₋₀)) ← 1	*5	
		@H+mem.bit	2	2	(H+mem ₃₋₀ .bit) ← 1	*1	
	CLR1	mem.bit	2	2	(mem.bit) ← 0	*3	
		fmem.bit	2	2	(fmem.bit) ← 0	*4	
		pmem.@L	2	2	(pmem ₇₋₂ +L ₃₋₂ .bit(L ₁₋₀)) ← 0	*5	
		@H+mem.bit	2	2	(H+mem ₃₋₀ .bit) ← 0	*1	
	SKT	mem.bit	2	2+S	Skip if (mem.bit) = 1	*3	(mem.bit) = 1
		fmem.bit	2	2+S	Skip if (fmem.bit) = 1	*4	(fmem.bit) = 1
		pmem.@L	2	2+S	Skip if (pmem ₇₋₂ +L ₃₋₂ .bit(L ₁₋₀)) = 1	*5	(pmem.@L) = 1
		@H+mem.bit	2	2+S	Skip if (H+mem ₃₋₀ .bit) = 1	*1	(@H+mem.bit) = 1
	SKF	mem.bit	2	2+S	Skip if (mem.bit) = 0	*3	(mem.bit) = 0
		fmem.bit	2	2+S	Skip if (fmem.bit) = 0	*4	(fmem.bit) = 0
		pmem.@L	2	2+S	Skip if (pmem ₇₋₂ +L ₃₋₂ .bit(L ₁₋₀)) = 0	*5	(pmem.@L) = 0
		@H+mem.bit	2	2+S	Skip if (H+mem ₃₋₀ .bit) = 0	*1	(@H+mem.bit) = 0

Instruction group	Mnemonic	Operand	Number of bytes	Number of machine cycles	Operation	Addressing area	Skip condition
Memory bit manipulation instructions	SKTCLR	fmem.bit	2	2+S	Skip if (fmem.bit) = 1 and clear	*4	(fmem.bit) = 1
		pmem.@L	2	2+S	Skip if (pmem _{7-2+L3-2} .bit(L ₁₋₀)) = 1 and clear	*5	(pmem.@L) = 1
		@H+mem.bit	2	2+S	Skip if (H+mem ₃₋₀ .bit) = 1 and clear	*1	(@H+mem.bit) = 1
	AND1	CY, fmem.bit	2	2	CY ← CY ∧ (fmem.bit)	*4	
		CY, pmem.@L	2	2	CY ← CY ∧ (pmem _{7-2+L3-2} .bit(L ₁₋₀))	*5	
		CY, @H+mem.bit	2	2	CY ← CY ∧ (H+mem ₃₋₀ .bit)	*1	
	OR1	CY, fmem.bit	2	2	CY ← CY ∨ (fmem.bit)	*4	
		CY, pmem.@L	2	2	CY ← CY ∨ (pmem _{7-2+L3-2} .bit(L ₁₋₀))	*5	
		CY, @H+mem.bit	2	2	CY ← CY ∨ (H+mem ₃₋₀ .bit)	*1	
	XOR1	CY, fmem.bit	2	2	CY ← CY ⊕ (fmem.bit)	*4	
		CY, pmem.@L	2	2	CY ← CY ⊕ (pmem _{7-2+L3-2} .bit(L ₁₋₀))	*5	
		CY, @H+mem.bit	2	2	CY ← CY ⊕ (H+mem ₃₋₀ .bit)	*1	
Branch instructions	BR ^{Note 1}	addr	–	–	PC ₁₀₋₀ ← addr (Select appropriate instruction among BR !addr, BRCB !caddr, and BR \$addr according to the assembler being used.)	*6	
		addr1	–	–	PC ₁₀₋₀ ← addr1 (Select appropriate instruction among BR !addr, BRA !addr1, BRCB !caddr, and BR \$addr1 according to the assembler being used.)	*11	
		!addr	3	3	PC ₁₀₋₀ ← addr	*6	
		\$addr	1	2	PC ₁₀₋₀ ← addr	*7	
		\$addr1	1	2	PC ₁₀₋₀ ← addr1		
		PCDE	2	3	PC ₁₀₋₀ ← PC ₁₀₋₈ +DE		
		PCXA	2	3	PC ₁₀₋₀ ← PC ₁₀₋₈ +XA		
		BCDE	2	3	PC ₁₀₋₀ ← BCDE ^{Note 2}	*6	
		BCXA	2	3	PC ₁₀₋₀ ← BCXA ^{Note 2}	*6	
	BRA ^{Note 1}	!addr1	3	3	PC ₁₀₋₀ ← addr1	*11	
BRCB	!caddr	2	2	PC ₁₀₋₀ ← caddr ₁₀₋₀	*8		

Notes 1. The above operations in the shaded boxes can be performed only in the Mk II mode. The other operations can be performed only in the MK I mode.

2. “0” must be set to the B register.

Instruction group	Mnemonic	Operand	Number of bytes	Number of machine cycles	Operation	Addressing area	Skip condition
Subroutine stack control instructions	CALLA ^{Note}	!addr1	3	3	(SP-2) ← x, x, MBE, RBE (SP-6) (SP-3) (SP-4) ← 0, PC ₁₀₋₀ (SP-5) ← 0, 0, 0, 0 PC ₁₀₋₀ ← addr1, SP ← SP-6	*11	
	CALL ^{Note}	!addr	3	3	(SP-3) ← MBE, RBE, 0, 0 (SP-4) (SP-1) (SP-2) ← 0, PC ₁₀₋₀ PC ₁₀₋₀ ← addr, SP ← SP-4	*6	
				4	(SP-2) ← x, x, MBE, RBE (SP-6) (SP-3) (SP-4) ← 0, PC ₁₀₋₀ (SP-5) ← 0, 0, 0, 0 PC ₁₀₋₀ ← addr, SP ← SP-6		
	CALLF ^{Note}	!faddr	2	2	(SP-3) ← MBE, RBE, 0, 0 (SP-4) (SP-1) (SP-2) ← 0, PC ₁₀₋₀ PC ₁₀₋₀ ← 0+faddr, SP ← SP-4	*9	
				3	(SP-2) ← x, x, MBE, RBE (SP-6) (SP-3) (SP-4) ← 0, PC ₁₀₋₀ (SP-5) ← 0, 0, 0, 0 PC ₁₀₋₀ ← 0+faddr, SP ← SP-6		
	RET ^{Note}		1	3	PC ₁₀₋₀ ← (SP) ₂₋₀ (SP+3) (SP+2) MBE, RBE, 0, 0 ← (SP+1), SP ← SP+4		
					x, x, MBE, RBE ← (SP+4) 0, 0, 0, 0 ← (SP+1) PC ₁₀₋₀ ← (SP) ₂₋₀ (SP+3) (SP+2), SP ← SP+6		
	RETS ^{Note}		1	3+S	MBE, RBE, 0, 0 ← (SP+1) PC ₁₀₋₀ ← (SP) ₂₋₀ (SP+3) (SP+2) SP ← SP+4 then skip unconditionally		Unconditional
					0, 0, 0, 0 ← (SP+1) PC ₁₀₋₀ ← (SP) ₂₋₀ (SP+3) (SP+2) x, x, MBE, RBE ← (SP+4) SP ← SP+6 then skip unconditionally		
	RETJ ^{Note}		1	3	MBE, RBE, 0, 0 ← (SP+1) PC ₁₀₋₀ ← (SP) ₂₋₀ (SP+3) (SP+2) PSW ← (SP+4) (SP+5), SP ← SP+6		
0, 0, 0, 0 ← (SP+1) PC ₁₀₋₀ ← (SP) ₂₋₀ (SP+3) (SP+2) PSW ← (SP+4) (SP+5), SP ← SP+6							
PUSH	rp	1	1	(SP-1) (SP-2) ← rp, SP ← SP-2			
	BS	2	2	(SP-1) ← MBS, (SP-2) ← RBS, SP ← SP-2			
POP	rp	1	1	rp ← (SP+1) (SP), SP ← SP+2			
	BS	2	2	MBS ← (SP+1), RBS ← (SP), SP ← SP+2			

Note The above operations in the shaded boxes can be performed only in the Mk II mode. The other operations can be performed only in the Mk I mode.

Instruction group	Mnemonic	Operand	Number of bytes	Number of machine cycles	Operation	Addressing area	Skip condition	
Interrupt control instructions	EI		2	2	IME (IPS.3) ← 1			
		IE _{xxx}	2	2	IE _{xxx} ← 1			
	DI		2	2	IME (IPS.3) ← 0			
		IE _{xxx}	2	2	IE _{xxx} ← 0			
Input/output instructions	IN ^{Note 1}	A, PORT _n	2	2	A ← PORT _n (n = 3, 6, 7, 8)			
	OUT ^{Note 1}	PORT _n , A	2	2	PORT _n ← A (n = 3, 6, 8)			
CPU control instructions	HALT		2	2	Set HALT Mode (PCC.2 ← 1)			
	STOP		2	2	Set STOP Mode (PCC.3 ← 1)			
	NOP		1	1	No Operation			
Special instructions	SEL	RB _n	2	2	RBS ← n (n = 0-3)			
		MB _n	2	2	MBS ← n (n = 0, 15)			
	GETI ^{Notes 2, 3}	taddr	1	3	<ul style="list-style-type: none"> When TBR instruction PC₁₀₋₀ ← (taddr)₂₋₀ + (taddr+1) 	*10		
					<ul style="list-style-type: none"> When TCALL instruction (SP-4) (SP-1) (SP-2) ← 0, PC₁₀₋₀ (SP-3) ← MBE, RBE, 0, 0 PC₁₀₋₀ ← (taddr)₂₋₀ + (taddr+1) SP ← SP-4 			
					<ul style="list-style-type: none"> When instruction other than TBR and TCALL instructions (taddr) (taddr+1) instruction is executed. 			Depending on the reference instruction
					<ul style="list-style-type: none"> When TBR instruction PC₁₀₋₀ ← (taddr)₂₋₀ + (taddr+1) 			*10
<ul style="list-style-type: none"> When TCALL instruction (SP-6) (SP-3) (SP-4) ← PC₁₀₋₀ (SP-5) ← 0, 0, 0, 0 (SP-2) ← x, x, MBE, RBE PC₁₀₋₀ ← (taddr)₂₋₀ + (taddr+1) SP ← SP-6 								
<ul style="list-style-type: none"> When instruction other than TBR and TCALL instructions (taddr) (taddr+1) instruction is executed. 		Depending on the reference instruction						

- Notes**
- While the IN instruction and OUT instruction are being executed, MBS must be set to 0, or MBE must be set to 1 and MBS must be set to 15.
 - The TBR and TCALL instructions are the table definition assembler pseudo instructions of the GETI instruction.
 - The above operations in the shaded boxes can be performed only in the Mk II mode. The other operations can be performed only in the Mk I mode.

12. ELECTRICAL SPECIFICATIONS

Absolute Maximum Ratings (T_A = 25 °C)

Parameter	Symbol	Test Conditions		Ratings	Unit
Supply voltage	V _{DD}			-0.3 to +7.0	V
Input voltage	V _I			-0.3 to V _{DD} + 0.3	V
Output voltage	V _O			-0.3 to V _{DD} + 0.3	V
Output current, high	I _{OH}	Per pin	Pins except P32	-10	mA
			Only P32	-20	mA
		All pins total		-30	mA
Output current, low	I _{OL}	Per pin		20	mA
		All pins total		90	mA
Operating ambient temperature	T _A			-40 to +85	°C
Storage temperature	T _{stg}			-65 to +150	°C

Caution If any of the parameters exceeds the absolute maximum ratings, even momentarily, the quality of the product may be impaired. The absolute maximum ratings are values that may physically damage the products. Be sure to use the products within the ratings.

Capacitance (T_A = 25 °C, V_{DD} = 0 V)

Parameter	Symbol	Test Conditions	MIN.	TYP.	MAX.	Unit
Input capacitance	C _{IN}	f = 1 MHz			15	pF
Output capacitance	C _{OUT}	Unmeasured pins returned to 0 V			15	pF
I/O capacitance	C _{IO}				15	pF

System Clock Oscillator Characteristics (T_A = -40 to +85 °C, V_{DD} = 1.8 to 6.0 V)

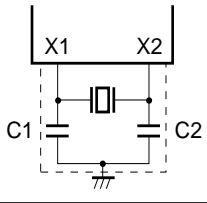
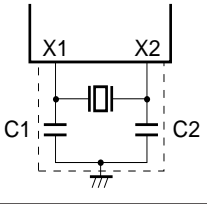
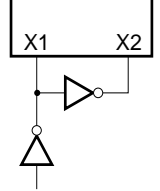
Resonator	Recommended Constant	Parameter	Testing Conditions	MIN.	TYP.	MAX.	Unit
Ceramic resonator		Oscillation frequency (f _x) ^{Note 1}		1.0		6.0 ^{Note 2}	MHz
		Oscillation stabilization time ^{Note 3}	After V _{DD} reaches MIN. value of oscillation voltage range			4	ms
Crystal resonator		Oscillation frequency (f _x) ^{Note 1}		1.0		6.0 ^{Note 2}	MHz
		Oscillation stabilization time ^{Note 3}	V _{DD} = 4.5 to 6.0 V			10	ms
						30	ms
External clock		X1 input frequency (f _x) ^{Note 1}		1.0		6.0 ^{Note 2}	MHz
		X1 input high- and low-level widths (t _{xH} , t _{xL})		83.3		500	ns

- Notes**
1. Only the oscillator characteristics are shown. For the instruction execution time, refer to **AC Characteristics**.
 2. If the oscillation frequency is 4.19 MHz < f_x ≤ 6.0 MHz at 1.8 V ≤ V_{DD} < 2.7 V, set the processor clock control register (PCC) to a value other than 0011. If the PCC is set to 0011, the rated machine cycle time of 0.95 μs is not satisfied.
 3. The oscillation stabilization time is the time required for oscillation to stabilize after application of V_{DD}, or after the STOP mode has been released.

Caution When using the oscillation circuit of the system clock, wire the portion enclosed in dotted lines in the figures as follows to avoid adverse influences on the wiring capacitance:

- Keep the wire length as short as possible.
- Do not cross other signal lines.
- Do not route the wiring in the vicinity of lines through which a high fluctuating current flows.
- Always keep the ground point of the capacitor of the oscillation circuit as the same potential as V_{SS}.
- Do not connect the power source pattern through which a high current flows.
- Do not extract signals from the oscillation circuit.

RECOMMENDED CIRCUIT CONSTANTS

Ceramic Resonator (T_A = -20 to +80 °C)

Manufacturer	Product	Frequency (MHz)	Circuit constant (pF)		Oscillation voltage range (V _{DD})		Remark
			C1	C2	MIN.(V)	MAX.(V)	
Murata Mfg. Co., Ltd.	CSB1000J ^{Note}	1.0	100	100	2.0	6.0	Rd = 2.2 kΩ
	CSA2.00MG040	2.0	100	100			-
	CST2.00MG040		-	-	Capacitor incorporated		
	CSA4.00MG	4.0	30	30	-		
	CST4.00MGW		-	-	Capacitor incorporated		
	CSA4.00MGU	4.0	30	30	1.8	-	
	CST4.00MGWU		-	-	Capacitor incorporated		
	CSA4.19MG	4.19	30	30	2.0	-	
	CST4.19MGW		-	-	Capacitor incorporated		
	CSA4.19MGU	4.19	30	30	1.8	-	
	CST4.19MGWU		-	-	Capacitor incorporated		
	CSA6.00MG	6.0	30	30	2.9	-	
	CST6.00MGW		-	-	Capacitor incorporated		
	CSA6.00MGU	6.0	30	30	2.4	-	
CST6.00MGWU	-		-	Capacitor incorporated			
Kyocera Corp.	KBR-1000F/Y	1.0	100	100	1.8	6.0	-
	KBR-2.0MS	2.0	68	68	2.0		-
	KBR-4.19MKC	4.19	-	-	1.8	Capacitor incorporated	
	KBR-4.19MSB		33	33		-	
	PBRC4.19A	4.19	-	-	1.8	Capacitor incorporated	
	PBRC4.19B		-	-		-	
	KBR-6.0MKC	6.0	33	33	1.8	-	
	KBR-6.0MSB		33	33		-	
	PBRC6.00A		-	-		-	
	PBRC6.00B		-	-		Capacitor incorporated	

Note If using Murata's CSB1000J (1.0 MHz) as the ceramic resonator, a limited resistor (R_d = 2.2 kΩ) is required (see figure below). If using any other recommended resonator, no limited resistor is needed.

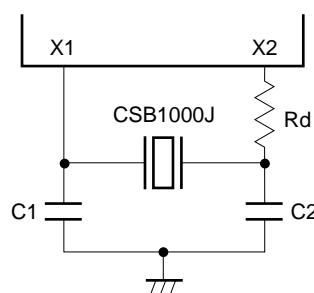

Caution The oscillation circuit constants and oscillation voltage range indicate conditions for stable oscillation, but do not guarantee oscillation frequency accuracy. If oscillation frequency accuracy is required for actual circuits, it is necessary to adjust the oscillation frequency of the resonator in the circuit. Please inquire directly to the maker of the resonator for data as needed.

DC Characteristics (T_A = -40 to +85 °C, V_{DD} = 1.8 to 6.0 V)

Parameter	Symbol	Conditions		MIN.	TYP.	MAX.	Unit
High-level output current	I _{OH}	Per pin	Pins except P32			-5	mA
			Only P32, V _{DD} = 3.0 V, V _{OH} = V _{DD} -2.0 V		-7	-15	mA
		All pins total				-20	mA
Low-level output current	I _{OL}	Per pin				15	mA
		All pins total				45	mA
High-level input voltage	V _{IH1}	Port 3	2.7 V ≤ V _{DD} ≤ 6.0 V	0.7 V _{DD}		V _{DD}	V
			1.8 V ≤ V _{DD} < 2.7 V	0.9 V _{DD}		V _{DD}	V
	V _{IH2}	Ports 6-8, KRREN, RESET	2.7 V ≤ V _{DD} ≤ 6.0 V	0.8 V _{DD}		V _{DD}	V
			1.8 V ≤ V _{DD} < 2.7 V	0.9 V _{DD}		V _{DD}	V
V _{IH3}	X1		V _{DD} -0.1		V _{DD}	V	
Low-level input voltage	V _{IL1}	Port 3	2.7 V ≤ V _{DD} ≤ 6.0 V	0		0.3 V _{DD}	V
			1.8 V ≤ V _{DD} < 2.7 V	0		0.1 V _{DD}	V
	V _{IL2}	Ports 6-8, KRREN, RESET	2.7 V ≤ V _{DD} ≤ 6.0 V	0		0.2 V _{DD}	V
			1.8 V ≤ V _{DD} < 2.7 V	0		0.1 V _{DD}	V
V _{IL3}	X1		0		0.1	V	
High-level output voltage	V _{OH}	V _{DD} = 4.5 to 6.0 V, I _{OH} = -1.0 mA		V _{DD} -1.0			V
		V _{DD} = 1.8 to 6.0 V, I _{OH} = -100 μA		V _{DD} -0.5			V
Low-level output voltage	V _{OL}	V _{DD} = 4.5 to 6.0 V	Port 3, I _{OL} = 15 mA		0.6	2.0	V
			Ports 6, 8, I _{OL} = 1.6 mA			0.4	V
		V _{DD} = 1.8 to 6.0 V, I _{OL} = 400 μA				0.5	V
High-level input leak current	I _{LIH1}	V _{IN} = V _{DD}	Pins except X1			3.0	μA
	I _{LIH2}		X1			20	μA
Low-level input leak current	I _{LIL1}	V _{IN} = 0 V	Pins except X1			-3.0	μA
	I _{LIL2}		X1			-20	μA
High-level output leak current	I _{LOH}	V _{OUT} = V _{DD}				3.0	μA
Low-level output leak current	I _{LOL}	V _{OUT} = 0 V				-3.0	μA
On-chip pull-up resistance	R _{L1}	V _{IN} = 0 V	Ports 3, 6, 8	50	100	200	kΩ
			Port 7 (mask option)	15	30	60	kΩ
	RESET (mask option)			50	100	200	kΩ
			R _{L2}				

DC Characteristics (T_A = -40 to +85 °C, V_{DD} = 1.8 to 6.0 V)

Parameter	Symbol	Test Conditions		MIN.	TYP.	MAX.	Unit	
Supply current ^{Note 1}	I _{DD1}	4.19 MHz	V _{DD} = 5.0 V ± 10 % ^{Note 2}		1.5	5.0	mA	
		Crystal resonator	V _{DD} = 3.0 V ± 10 % ^{Note 3}		0.23	1.0	mA	
	I _{DD2}	C1 = C2 = 22 pF	HALT mode	V _{DD} = 5.0 V ± 10 %		0.64	3.0	mA
				V _{DD} = 3.0 V ± 10 %		0.20	0.9	mA
	I _{DD3}	X1 = 0 V STOP mode	V _{DD} = 1.8 to 6.0 V				5	μA
				T _A = 25 °C				1
			V _{DD} = 3.0 V ± 10 %			0.1	3	μA
T _A = -40 to +40 °C					0.1	1	μA	

- Notes**
1. Does not include current fed to on-chip pull-up resistor.
 2. When processor clock control register (PCC) is set to 0011, during high-speed mode.
 3. When PCC is set to 0000, during low-speed mode.

AC Characteristics (T_A = -40 to +85 °C, V_{DD} = 1.8 to 6.0 V)

Parameter	Symbol	Test Conditions	MIN.	TYP.	MAX.	Unit	
CPU clock cycle time ^{Note 1} (Minimum instruction execution time = 1 machine cycle)	t _{cy}	When system clock is used	2.7 V ≤ V _{DD} ≤ 6.0 V	0.67		64.0	μs
			1.8 V ≤ V _{DD} < 2.7 V	0.95		64.0	μs
Interrupt input high- and low-level widths	t _{INTH} , t _{INTL}	INT0	IM02 = 0	Note 2		μs	
			IM02 = 1	10		μs	
		KR4-KR7	10		μs		
RESET low-level width	t _{RSL}		10			μs	

- Notes 1.** The CPU clock (Φ) cycle time (minimum instruction execution time) is determined by the oscillation frequency of the connected resonator (and external clock) and the processor clock control register (PCC). The figure on the right shows the cycle time t_{cy} characteristics against the supply voltage V_{DD} when the system clock is used.
- 2.** 2t_{cy} or 128/f_x depending on the setting of the interrupt mode register (IM0).

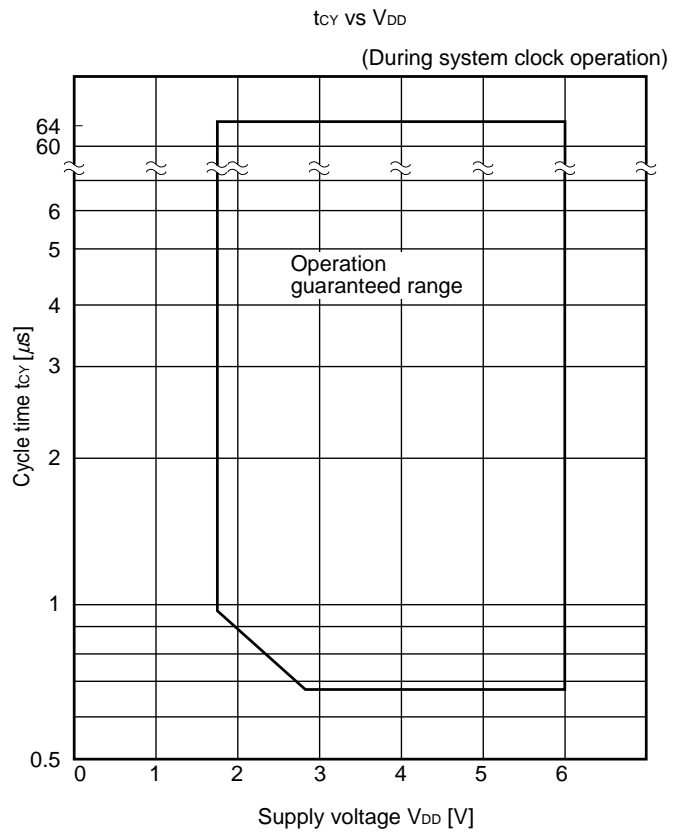

AC Timing Test Points (Excluding X1 Input)



Clock Timing

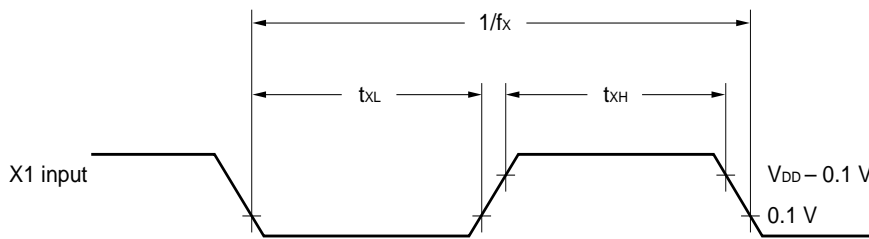

Interrupt Input Timing

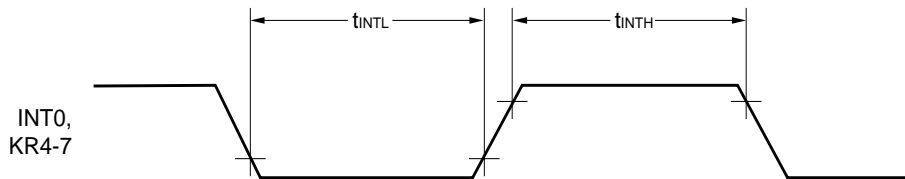

\overline{RESET} Input Timing

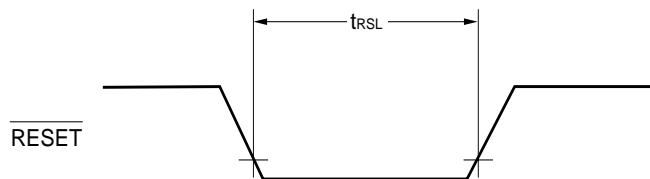

Data Memory STOP Mode Low-Supply Voltage Data Retention Characteristics (T_A = -40 to +85 °C)

Parameter	Symbol	Test Conditions	MIN.	TYP.	MAX.	Unit
Release signal set time	t _{SREL}		0			μs
Oscillation stabilization wait time ^{Note 1}	t _{WAIT}	Release by $\overline{\text{RESET}}$		Note 2		ms
		Release by interrupt request		Note 3		ms

- Notes**
1. The oscillation stabilization wait time is the time during which the CPU operation is stopped to avoid unstable operation at oscillation start.
 2. $2^{17}/f_x$ and $2^{15}/f_x$ can be selected with mask option.
 3. Depends on setting of basic interval timer mode register (BTM) (see table below).

BTM3	BTM2	BTM1	BTM0	Wait Time	
				When f _x = 4.19 MHz	When f _x = 6.0 MHz
-	0	0	0	2 ²⁰ /f _x (Approx. 250 ms)	2 ²⁰ /f _x (Approx. 175 ms)
-	0	1	1	2 ¹⁷ /f _x (Approx. 31.3 ms)	2 ¹⁷ /f _x (Approx. 21.8 ms)
-	1	0	1	2 ¹⁵ /f _x (Approx. 7.81 ms)	2 ¹⁵ /f _x (Approx. 5.46 ms)
-	1	1	1	2 ¹³ /f _x (Approx. 1.95 ms)	2 ¹³ /f _x (Approx. 1.37 ms)

Data Retention Timing (on releasing STOP mode by $\overline{\text{RESET}}$)

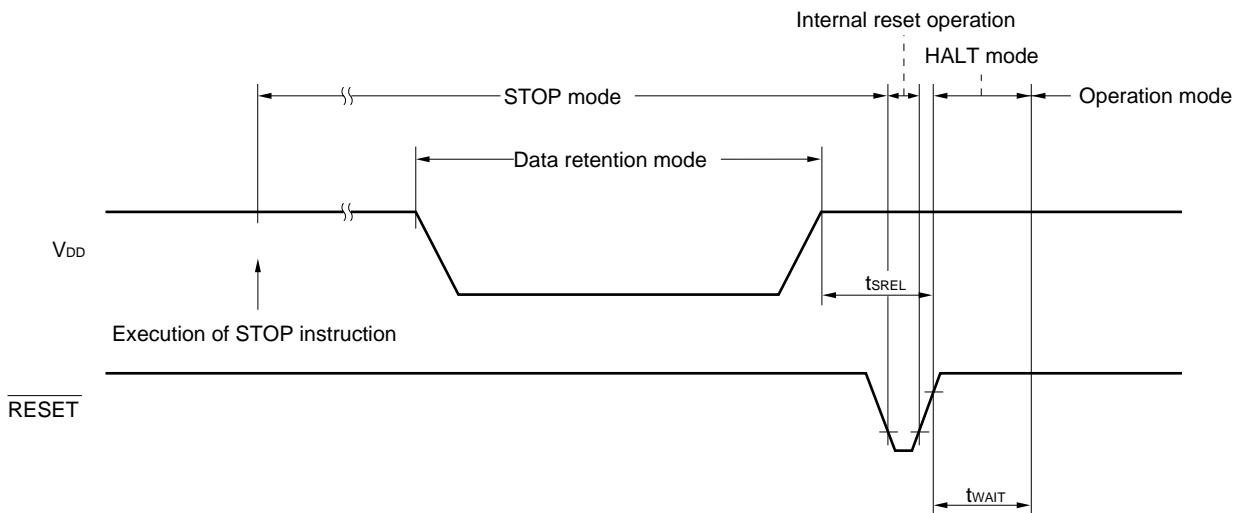

Data Retention Timing (Standby release signal: on releasing STOP mode by interrupt signal)

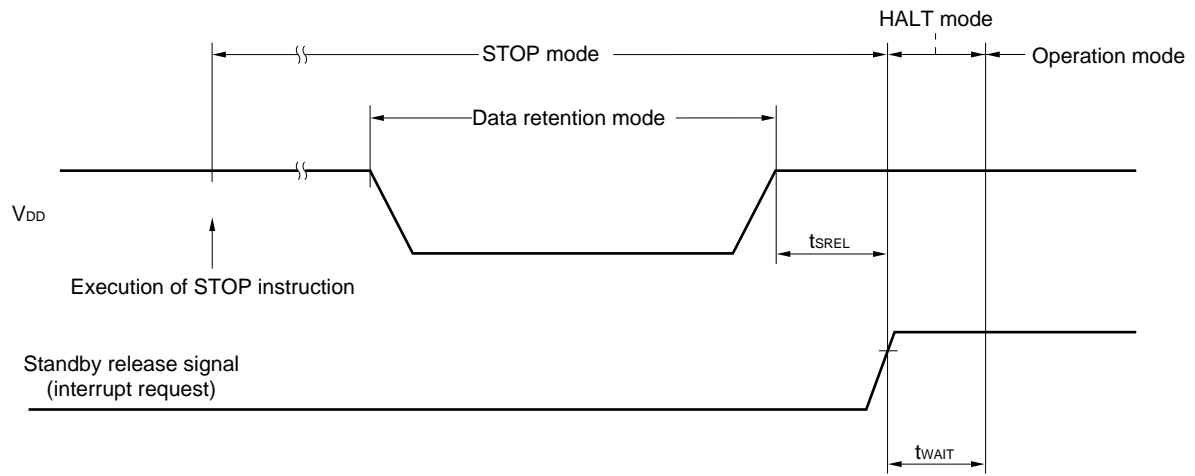

13. CHARACTERISTIC CURVES (REFERENCE VALUES)

I_{DD} vs V_{DD} (System clock: 6.0-MHz crystal resonator)

(T_A = 25 °C)

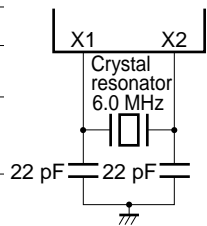
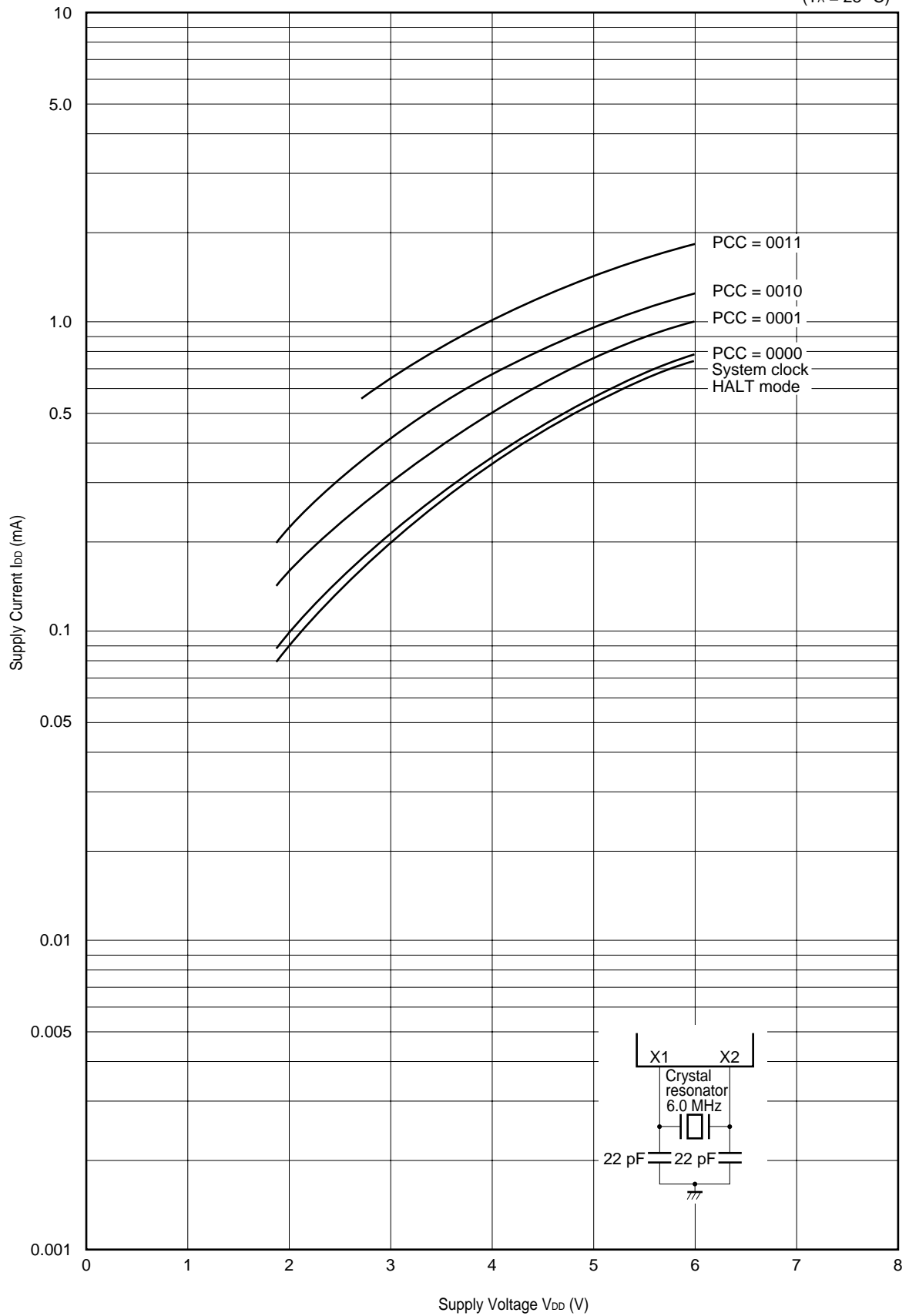

I_{DD} vs V_{DD} (System clock: 4.19-MHz crystal resonator)

(T_A = 25 °C)

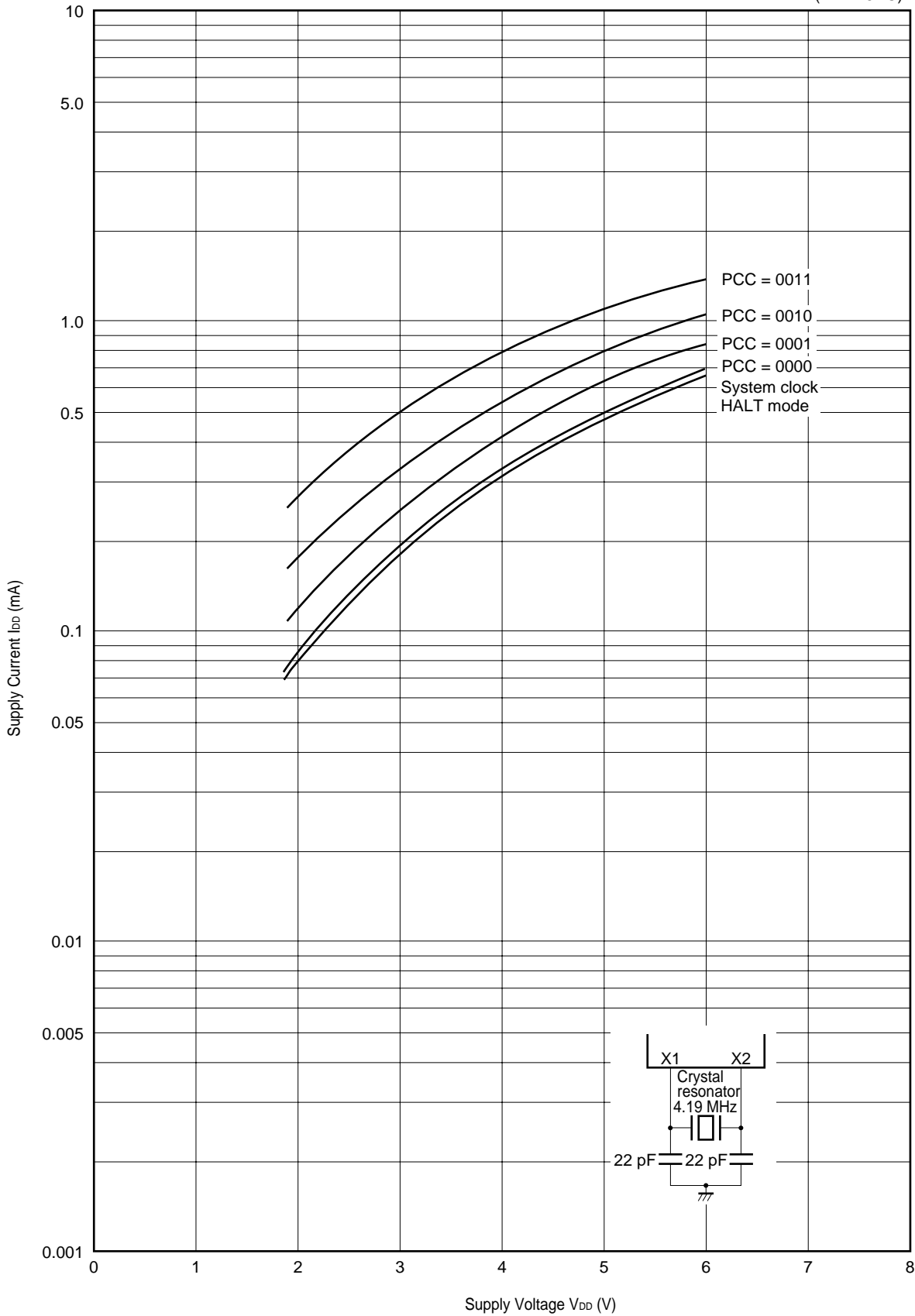

14. PACKAGE DRAWINGS

20 PIN PLASTIC SOP (300 mil)

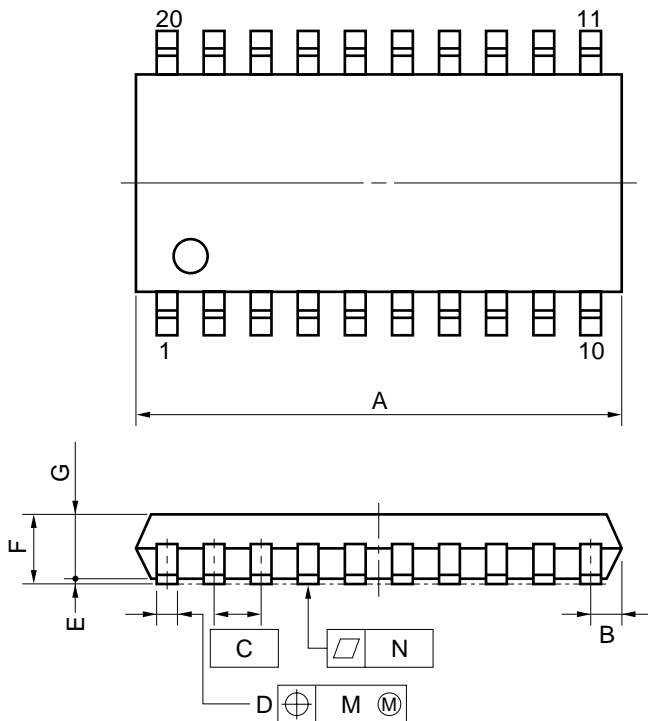

detail of lead end

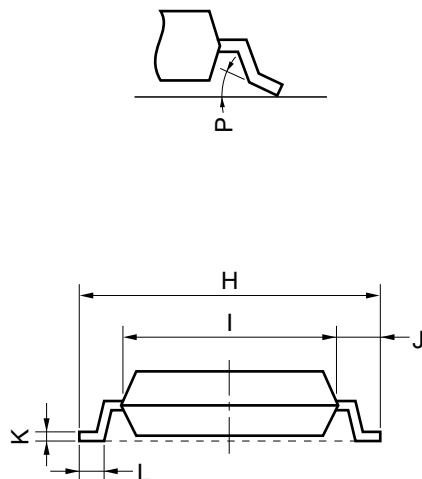

NOTE

Each lead centerline is located within 0.12 mm (0.005 inch) of its true position (T.P.) at maximum material condition.

ITEM	MILLIMETERS	INCHES
A	13.00 MAX.	0.512 MAX.
B	0.78 MAX.	0.031 MAX.
C	1.27 (T.P.)	0.050 (T.P.)
D	0.40 ^{+0.10} _{-0.05}	0.016 ^{+0.004} _{-0.003}
E	0.1±0.1	0.004±0.004
F	1.8 MAX.	0.071 MAX.
G	1.55	0.061
H	7.7±0.3	0.303±0.012
I	5.6	0.220
J	1.1	0.043
K	0.20 ^{+0.10} _{-0.05}	0.008 ^{+0.004} _{-0.002}
L	0.6±0.2	0.024 ^{+0.008} _{-0.009}
M	0.12	0.005
N	0.10	0.004
P	3° ^{+7°} _{-3°}	3° ^{+7°} _{-3°}

P20GM-50-300B, C-4

20 PIN PLASTIC SHRINK SOP (300 mil)

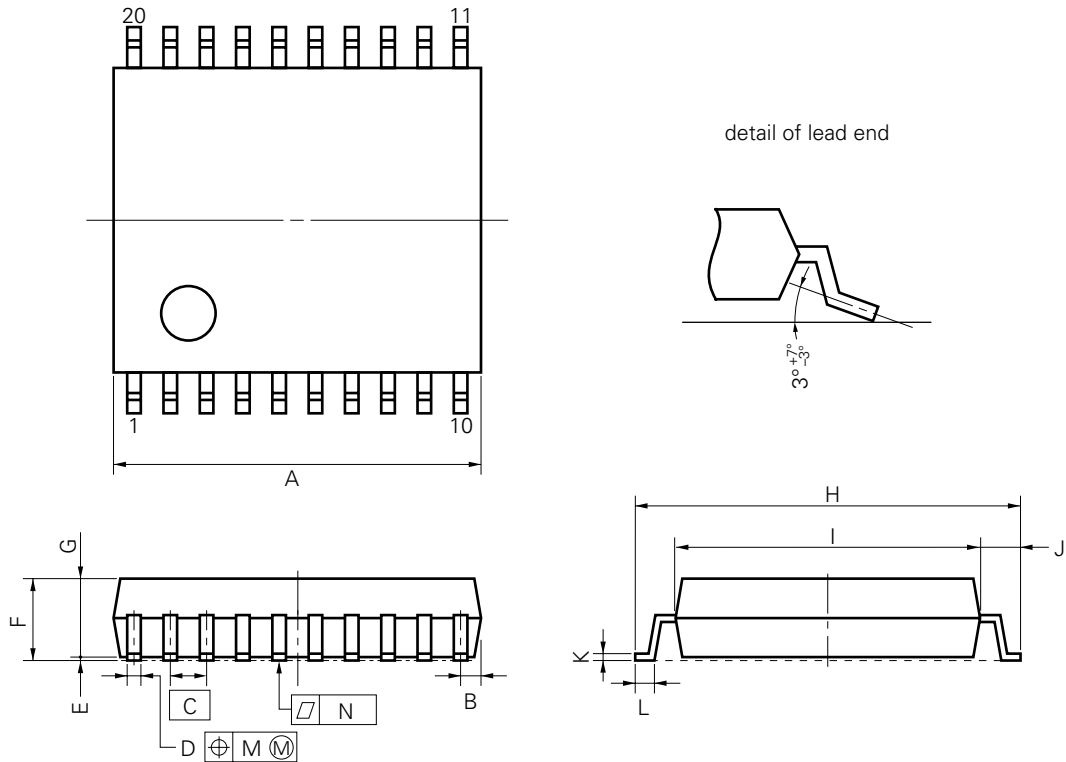

NOTE

Each lead centerline is located within 0.12 mm (0.005 inch) of its true position (T.P.) at maximum material condition.

P20GM-65-300B-2

ITEM	MILLIMETERS	INCHES
A	7.00 MAX.	0.276 MAX.
B	0.575 MAX.	0.023 MAX.
C	0.65 (T.P.)	0.026 (T.P.)
D	0.30±0.10	0.012 ^{+0.004} _{-0.005}
E	0.125±0.075	0.005±0.003
F	2.0 MAX.	0.079 MAX.
G	1.7	0.067
H	8.1±0.3	0.319±0.012
I	6.1±0.2	0.240±0.008
J	1.0±0.2	0.039 ^{+0.009} _{-0.008}
K	0.15 ^{+0.10} _{-0.05}	0.006 ^{+0.004} _{-0.002}
L	0.5±0.2	0.020 ^{+0.008} _{-0.009}
M	0.12	0.005
N	0.10	0.004

15. RECOMMENDED SOLDERING CONDITIONS

The μPD754202 should be soldered and mounted under the following recommended conditions.

For the details of the recommended soldering conditions, refer to the document **Semiconductor Device Mounting Technology Manual (C10535E)**.

For soldering methods and conditions other than those recommended below, contact your NEC sales representative.

Table 15-1. Surface Mounting Type Soldering Conditions

- μPD754202GS-xxx-BA5 : 20-pin plastic SOP (300 mil, 1.27-mm pitch)
- μPD754202GS-xxx-GJG : 20-pin plastic shrink SOP (300 mil, 0.65-mm pitch)
- μPD754202GS(A)-xxx-BA5 : 20-pin plastic SOP (300 mil, 1.27-mm pitch)
- μPD754202GS(A)-xxx-GJG : 20-pin plastic shrink SOP (300 mil, 0.65-mm pitch)

Soldering Method	Soldering Conditions	Symbol
Infrared reflow	Package peak temperature: 235 °C, Reflow time: 30 seconds or below (at 210 °C or higher), Number of reflow processes: Twice or less	IR35-00-2
VPS	Package peak temperature: 215 °C, Reflow time: 40 seconds or below (at 200 °C or higher), Number of reflow processes: Twice or less	VP15-00-2
Wave soldering	Solder temperature: 260 °C or below, Flow time: 10 seconds or below, Number of flow processes: 1 Preheating temperature: 120 °C or below (package surface temperature)	WS60-00-1
Partial heating	Pin temperature: 300 °C or below, Time: 3 seconds or below (per side of device)	—

Caution Do not use different soldering methods together (except for partial heating).

APPENDIX A. μPD754202, 75F4264 FUNCTION LIST

Item		μPD754202	μPD75F4264 ^{Note}
Program memory		Mask ROM 0000H-07FFH (2048 × 8 bits)	Flash memory 0000H-0FFFH (4096 × 8 bits)
Data memory	Static RAM	000H-07FH (128 × 4 bits)	
	EEPROM™	None	400H-43FH (32 × 8 bits)
CPU		75XL CPU	
General-purpose register		(4 bits × 8 or 8 bits × 4) × 4 banks	
Instruction execution time		<ul style="list-style-type: none"> • 0.95, 1.91, 3.81, 15.3 μs (system clock: at 4.19-MHz operation) • 0.67, 1.33, 2.67, 10.7 μs (system clock: at 6.0-MHz operation) 	
I/O port	CMOS input	4 (on-chip pull-up resistor can be connected by mask option)	
	CMOS input/output	9 (on-chip pull-up resistor can be specified by software)	
	Total	13	
System clock oscillator		Ceramic/crystal oscillator	
Boot time after reset		2 ¹⁷ /f _x or 2 ¹⁵ /f _x (selected by mask option)	2 ¹⁵ /f _x
Timer		4 channels <ul style="list-style-type: none"> • 8-bit timer counter: 3 channels (can be used for 16-bit timer counter) • Basic interval timer/watchdog timer: 1 channel 	
A/D converter		None	<ul style="list-style-type: none"> • 8-bit resolution × 2 channels (successive approximation register) • Operable V_{DD} = 1.8 V or higher
Programmable threshold port		None	2 channels
Vectored interrupt		External: 1, Internal: 4	External: 1, Internal: 5
Test input		External: 1 (key return reset function provided)	
Supply voltage		V _{DD} = 1.8 to 6.0 V	
Operating ambient temperature		T _A = -40 to +85 °C	
Package		<ul style="list-style-type: none"> • 20-pin plastic SOP (300 mil, 1.27-mm pitch) • 20-pin plastic shrink SOP (300 mil, 0.65-mm pitch) 	<ul style="list-style-type: none"> • 20-pin plastic SOP (300 mil, 1.27-mm pitch)

Note Under development

APPENDIX B. DEVELOPMENT TOOLS

The following development tools are provided for system development using the μPD754202.

In the 75XL Series, the relocatable assembler which is common to the series is used in combination with the device file of each product.

Language processor

RA75X relocatable assembler	Host machine	OS	Supply media	Part number (product name)
		PC-9800 Series	MS-DOS™	
(Ver. 3.30 to Ver. 6.2 ^{Note})	5-inch 2HD		μS5A10RA75X	
IBM PC/AT™ and compatible machines	Refer to "OS for IBM PC"	3.5-inch 2HC	μS7B13RA75X	
		5-inch 2HC	μS7B10RA75X	

Device file	Host machine	OS	Supply media	Part number (product name)
		PC-9800 Series	MS-DOS	
(Ver. 3.30 to Ver. 6.2 ^{Note})	5-inch 2HD		μS5A10DF754202	
IBM PC/AT and compatible machines	Refer to "OS for IBM PC"	3.5-inch 2HC	μS7B13DF754202	
		5-inch 2HC	μS7B10DF754202	

Note Ver. 5.00 or later have the task swap function, but it cannot be used for this software.

Remark Operations of the assembler and device file are guaranteed only on the above host machines and OSs.

Debugging tool

The in-circuit emulators (IE-75000-R and IE-75001-R) are available as the program debugging tool for the μPD754202.

The system configurations are described as follows.

Hardware	IE-75000-R ^{Note 1}	In-circuit emulator for debugging the hardware and software when developing application systems that use the 75X Series and 75XL Series. When developing a μPD754202, the emulation board IE-75300-R-EM and emulation probe EP-754144GS-R that are sold separately must be used with the IE-75000-R. By connecting with the host machine, efficient debugging can be made. It contains the emulation board IE-75000-R-EM which is connected.			
	IE-75001-R	In-circuit emulator for debugging the hardware and software when developing application systems that use the 75X Series and 75XL Series. When developing a μPD754202, the emulation board IE-75300-R-EM and emulation probe EP-754144GS-R which are sold separately must be used with the IE-75001-R. By connecting with the host machine, efficient debugging can be made.			
	IE-75300-R-EM	Emulation board for evaluating the application systems that use a μPD754202. It must be used with the IE-75000-R or IE-75001-R.			
	EP-754144GS-R	Emulation probe for the μPD754202. It must be connected to IE-75000-R (or IE-75001-R) and IE-75300-R-EM. It is supplied with the 20-pin flexible boards EV-9500GS-20 (compatible with 20-pin plastic shrink SOP) and EV-9501GS-20 (compatible with 20-pin plastic SOP) which facilitate connection to a target system.			
Software	IE control program	Connects the IE-75000-R or IE-75001-R to a host machine via RS-232-C and Centronics I/F and controls the IE-75000-R or IE-75001-R on a host machine.			
		Host machine	OS	Supply media	Part number (product name)
		PC-9800 Series	MS-DOS (Ver. 3.30 to Ver. 6.2 ^{Note 2})	3.5-inch 2HD	μS5A13IE75X
				5-inch 2HD	μS5A10IE75X
		IBM PC/AT and compatible machines	Refer to "OS for IBM PC"	3.5-inch 2HC	μS7B13IE75X
5-inch 2HC	μS7B10IE75X				

Notes 1. Maintenance product

2. Ver. 5.00 or later have the task swap function, but it cannot be used for this software.

Remark Operation of the IE control program is guaranteed only on the above host machines and OSs.

OS for IBM PC

The following IBM PC OS's are supported.

OS	Version
PC DOS™	Ver. 5.02 to Ver. 6.3 J6.1/V ^{Note} to J6.3/V ^{Note}
MS-DOS	Ver. 5.0 to Ver. 6.22 5.0/V ^{Note} to J6.2/V ^{Note}
IBM DOS™	J5.02/V ^{Note}

Note Only English mode is supported.

Caution Ver. 5.0 or later have the task swap function, but it cannot be used for this software.

APPENDIX C. RELATED DOCUMENTS

The related documents indicated in this publication may include preliminary versions. However, preliminary versions are not marked as such.

Device related documents

Document Name	Document Number	
	Japanese	English
μPD754202, 754202(A) Data Sheet	U12181J	This document
μPD754202 User's Manual	U11132J	U11132E
75XL Series Selection Guide	U10453J	U10453E

Development tool related documents

Document Name		Document Number		
		Japanese	English	
Hardware	IE-75000-R/IE-75001-R User's Manual		EEU-846	EEU-1416
	IE-75300-R-EM User's Manual		U11354J	U11354E
	EP-754144GS-R User's Manual		U10695J	U10695E
Software	RA75X Assembler Package User's Manual	Operation	EEU-731	EEU-1346
		Language	EEU-730	EEU-1363

Other related documents

Document Name	Document Number	
	Japanese	English
IC Package Manual	C10943X	
Semiconductor Device Mounting Technology Manual	C10535J	C10535E
Quality Grades on NEC Semiconductor Devices	C11531J	C11531E
NEC Semiconductor Device Reliability/Quality Control System	C10983J	C10983E
Electrostatic Discharge (ESD) Test	MEM-539	–
Guide to Quality Assurance for Semiconductor Devices	C11893J	MEI-1202
Microcomputer Product Series Guide	U11416J	–

Caution These documents are subject to change without notice. Be sure to read the latest documents for designing, etc.

[MEMO]

NOTES FOR CMOS DEVICES

① PRECAUTION AGAINST ESD FOR SEMICONDUCTORS

Note: Strong electric field, when exposed to a MOS device, can cause destruction of the gate oxide and ultimately degrade the device operation. Steps must be taken to stop generation of static electricity as much as possible, and quickly dissipate it once, when it has occurred. Environmental control must be adequate. When it is dry, humidifier should be used. It is recommended to avoid using insulators that easily build static electricity. Semiconductor devices must be stored and transported in an anti-static container, static shielding bag or conductive material. All test and measurement tools including work bench and floor should be grounded. The operator should be grounded using wrist strap. Semiconductor devices must not be touched with bare hands. Similar precautions need to be taken for PW boards with semiconductor devices on it.

② HANDLING OF UNUSED INPUT PINS FOR CMOS

Note: No connection for CMOS device inputs can be cause of malfunction. If no connection is provided to the input pins, it is possible that an internal input level may be generated due to noise, etc., hence causing malfunction. CMOS device behave differently than Bipolar or NMOS devices. Input levels of CMOS devices must be fixed high or low by using a pull-up or pull-down circuitry. Each unused pin should be connected to V_{DD} or GND with a resistor, if it is considered to have a possibility of being an output pin. All handling related to the unused pins must be judged device by device and related specifications governing the devices.

③ STATUS BEFORE INITIALIZATION OF MOS DEVICES

Note: Power-on does not necessarily define initial status of MOS device. Production process of MOS does not define the initial operation status of the device. Immediately after the power source is turned ON, the devices with reset function have not yet been initialized. Hence, power-on does not guarantee out-pin levels, I/O settings or contents of registers. Device is not initialized until the reset signal is received. Reset operation must be executed immediately after power-on for devices having reset function.

Regional Information

Some information contained in this document may vary from country to country. Before using any NEC product in your application, please contact the NEC office in your country to obtain a list of authorized representatives and distributors. They will verify:

- Device availability
- Ordering information
- Product release schedule
- Availability of related technical literature
- Development environment specifications (for example, specifications for third-party tools and components, host computers, power plugs, AC supply voltages, and so forth)
- Network requirements

In addition, trademarks, registered trademarks, export restrictions, and other legal issues may also vary from country to country.

NEC Electronics Inc. (U.S.)

Santa Clara, California
 Tel: 800-366-9782
 Fax: 800-729-9288

NEC Electronics (Germany) GmbH

Duesseldorf, Germany
 Tel: 0211-65 03 02
 Fax: 0211-65 03 490

NEC Electronics (UK) Ltd.

Milton Keynes, UK
 Tel: 01908-691-133
 Fax: 01908-670-290

NEC Electronics Italiana s.r.l.

Milano, Italy
 Tel: 02-66 75 41
 Fax: 02-66 75 42 99

NEC Electronics (Germany) GmbH

Benelux Office
 Eindhoven, The Netherlands
 Tel: 040-2445845
 Fax: 040-2444580

NEC Electronics (France) S.A.

Velizy-Villacoublay, France
 Tel: 01-30-67 58 00
 Fax: 01-30-67 58 99

NEC Electronics (France) S.A.

Spain Office
 Madrid, Spain
 Tel: 01-504-2787
 Fax: 01-504-2860

NEC Electronics (Germany) GmbH

Scandinavia Office
 Taebby, Sweden
 Tel: 08-63 80 820
 Fax: 08-63 80 388

NEC Electronics Hong Kong Ltd.

Hong Kong
 Tel: 2886-9318
 Fax: 2886-9022/9044

NEC Electronics Hong Kong Ltd.

Seoul Branch
 Seoul, Korea
 Tel: 02-528-0303
 Fax: 02-528-4411

NEC Electronics Singapore Pte. Ltd.

United Square, Singapore 1130
 Tel: 253-8311
 Fax: 250-3583

NEC Electronics Taiwan Ltd.

Taipei, Taiwan
 Tel: 02-719-2377
 Fax: 02-719-5951

NEC do Brasil S.A.

Sao Paulo-SP, Brasil
 Tel: 011-889-1680
 Fax: 011-889-1689

EEPROM is a trademark of NEC Corporation.

MS-DOS is either a registered trademark or a trademark of Microsoft Corporation in the United States and/or other countries.

IBM DOS, PC/AT, and PC DOS are trademarks of International Business Machines Corporation.

The export of this product from Japan is regulated by the Japanese government. To export this product may be prohibited without governmental license, the need for which must be judged by the customer. The export or re-export of this product from a country other than Japan may also be prohibited without a license from that country. Please call an NEC sales representative.

No part of this document may be copied or reproduced in any form or by any means without the prior written consent of NEC Corporation. NEC Corporation assumes no responsibility for any errors which may appear in this document.

NEC Corporation does not assume any liability for infringement of patents, copyrights or other intellectual property rights of third parties by or arising from use of a device described herein or any other liability arising from use of such device. No license, either express, implied or otherwise, is granted under any patents, copyrights or other intellectual property rights of NEC Corporation or others.

While NEC Corporation has been making continuous effort to enhance the reliability of its semiconductor devices, the possibility of defects cannot be eliminated entirely. To minimize risks of damage or injury to persons or property arising from a defect in an NEC semiconductor device, customers must incorporate sufficient safety measures in its design, such as redundancy, fire-containment, and anti-failure features.

NEC devices are classified into the following three quality grades:

"Standard", "Special", and "Specific". The Specific quality grade applies only to devices developed based on a customer designated "quality assurance program" for a specific application. The recommended applications of a device depend on its quality grade, as indicated below. Customers must check the quality grade of each device before using it in a particular application.

Standard: Computers, office equipment, communications equipment, test and measurement equipment, audio and visual equipment, home electronic appliances, machine tools, personal electronic equipment and industrial robots

Special: Transportation equipment (automobiles, trains, ships, etc.), traffic control systems, anti-disaster systems, anti-crime systems, safety equipment and medical equipment (not specifically designed for life support)

Specific: Aircrafts, aerospace equipment, submersible repeaters, nuclear reactor control systems, life support systems or medical equipment for life support, etc.

The quality grade of NEC devices is "Standard" unless otherwise specified in NEC's Data Sheets or Data Books. If customers intend to use NEC devices for applications other than those specified for Standard quality grade, they should contact an NEC sales representative in advance.

Anti-radioactive design is not implemented in this product.