

Features

- Single power can operate at 2.4V through 6.0V.
- Current output could drive 8 ohm speaker with a transistor, Vout could drive buzzer directly.
- The voice content is stored up to 60 seconds at 5.8 KHz (55500h) for S6605 and can be separated to 128 sections. See next page for other device's data.
- Duration of each section can be different and is multiples of 100h.
- Total duration of all 128 sections with mute is up to 96 seconds (80000h).
- The voice content can be accessed in "Sentence" type on KeyBoard (KBD) and Matrix(MTX) modes. Up to 50 Sentences for KeyBoard, 56 Sentences for Matrix modes.
- Each sentence is composed of one or more than one section(s).
- Automatic power down .
- Three addressing interface modes are provided for versatile applications: CPU, KBD and MTX.
- KeyBoard addressing mode:
 - a. 50 sentences can be accessed by 15 addressing input dual-tree type trigger.
 - b. Sentence is numbered by 00 through 49.
 - c. 5 input pins on D-tree (D0-D4) tells the 1st digit (0 through 4), another 10 input pins on S-tree (S0-S9) tells the 2nd digit (0 through 9). By these two digits, all 50 sentences can be accessed.
 - d. With 2nd digit only also can access a sentence.
 - e. Section is located and numbered by 0 through 127.
 - f. Total section number of all sentences is up to 256.
- Matrix addressing mode:
 - a. 56 sentences can be accessed by 8x7 wiring matrix.
 - b. Sentence is numbered by 00 through 55.
 - c. Section is located and numbered by 0 through 127.
 - d. Total section number of all sentences is up to 256.
- CPU addressing mode:
 - a. 128 sections can be accessed by 7 address bits with an enable strobe trigger.
 - b. Section is located and numbered by 00 through 127 .
- Power on trigger play is available by bonding VSS and trigger together.
- A dedicate LED output pin with 6 Hz flash is provided to tell the audio status.
- Playall function (OKY) plays all up to 64 defined sentences one by one by single trigger.
- Playnext (sequential) function (OKY) : one trigger plays next sentence of up to 64 defined sentences circularly.
- Random-play function (OKY) : one trigger plays one of 64 defined sentences randomly.
- Continue sequence(PLAYNEXT):The first OKY trigger after any addressing will keep current sequence continuously.
- Home sequence(PLAYNEXT):The first OKY trigger after any addressing will return the sequence to the first sentence.
- Automatically ramp up & ramp down.
- Sound Sentence & quality could be emulated on 9009 board.

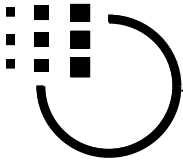

Description

The MSS6605 is a single-chip CMOS VLSI ROM that can memorize voice up to 60 seconds using MOSEL qualified coding method (MPCM) at 5.8 KHz.

Three addressing interfaces are provided: CPU mode, KEYBOARD mode and MATRIX mode for versatile applications. The voice content can be stored separately into 128 sections or 50 or 56 sentences with arbitrary length. With minimum external components, this chip can be applied to various application. Customer voice data will be edited and programmed into ROM by changing one mask during fabrication.

Block Diagram

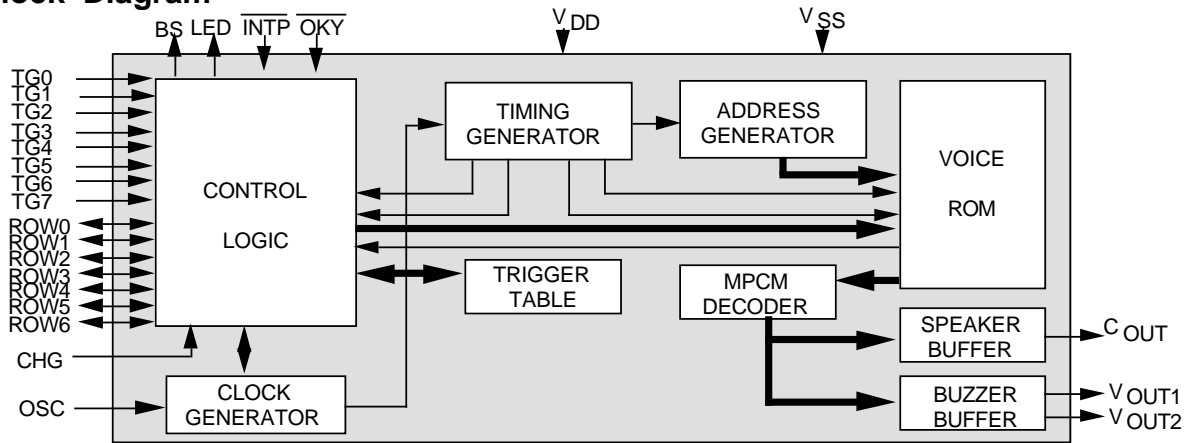

Mask option for

- either Level or Edge trigger type for MTX and KBD addressing modes.
- either Holdable or unholdable output type for MTX and KBD addressing modes.
- either retriggeable or not for all 3 addressing modes.
- either BUSY signal or STOP pulse output on BS output.
- either low or high active for STOP pulse output.
- random or playall or playnext (sequential) output on OKY (one key) input pin.
- either return to the 1st section (ORIGINAL) or keep continuing (CURRENT) for PLAYNEXT (sequential) function.
- 3 addressing interface modes.
- either slow (20ms) or regular (5ms) debounce time for MTX & KBD addressing mode.
- either long (80ms) or regular (40ms) stop pulse width.

Voice Storage Reference

Device	Capacity	Duration at 6 KHz S.R.	Section	Entry/Sentence
MSS6605	55500h	58.2 seconds	128	256/64
MSS4305	40000h	43.6 seconds	128	256/64
MSS3205	30000h	32.7 seconds	128	256/64
MSS2105	20000h	21.7 seconds	128	256/64

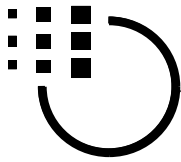

Pad Description

Pad No.	Signal Name	I/O	Active	Function
21~28	TG7 ~ TG0	I		CPU mode: address input (TG0 ~ TG6), internal pull high, negative strobe trigger (TG7). KBD mode: with ROW0 ~ROW6 for trigger input, internal pull high, active low. MTX mode: with ROW0 ~ROW6 for scanning function, internal pull high, active low.
1~7	ROW6~ROW0	NC/I/O		CPU mode: No connection. KBD mode: with TG0 ~ TG7 for trigger input, internal pull high, active low. ROW0~ROW4 are used as Decimal digit (D-tree) ROW5 and ROW6 are used for S-tree. MTX mode: with TG0 ~ TG7 for scanning function, used as output pins.
8	$\overline{\text{INTP}}$	I	L	Interrupt, stops the audio output at once;low active.
9	$\overline{\text{OKY}}$	I	L	One key Play, playall or playnext or random-play;active low.
10	LED	O		LED, sink current
11	CHG	I		Change addressing interface mode from existing mode
16	NC	NC		
12	C _{OUT}	O		Audio signal current output (for speaker)
13	V _{DD}	Power		Positive power supply
14	ROSC	I		Oscillator Resistor input
15,17	V _{SS}	Power		Negative power supply
18	V _{OUT2}	O		Audio signal voltage output (for buzzer)
19	V _{OUT1}	O		
20	BS	O		Busy / Stop

NC: No connection

Absolute Maximum Rating

Symbol	Name	Rating	Unit
V _{DD} - V _{SS}	DC supply voltage	-0.5 ~ +7.0	V
V _{IN}	Input voltage	V _{SS} - 0.3 ~ V _{DD} + 0.3	V
V _{OUT}	Output voltage	V _{SS} ~ V _{DD}	
T (Operating)	Operating Temperature	-10 ~ +60	°C
T (Storage)	Storage Temperature	-55 ~ +125	°C

Fosc Characteristics

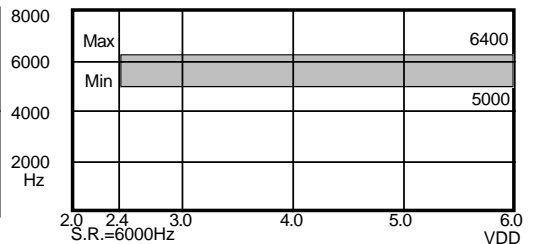

Specifications subject to change without notice, contact your sales representatives for the most recent information.

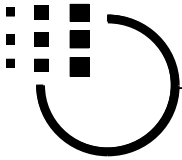

Signals

Cout

This pin can drive speaker through a transistor.

Cout is tristate during standby.

Cout has zero current output when sound data is zero. Cout has full current output when sound data is the highest. Cout has half of full current output when sound is silence at middle data value. Cout has half of full current output when playing sound at appended memory-less mute.

The bypass Cout Resistor is used to bypass the audio output current from Cout. This bypassing extra current to ground gives a way to prevent the saturation of audio waveform amplified by transistor. This Resistance is 470 ohm typically. It always is not very small. Or user can let it open if the transistor has a fair beta value.

A transistor with beta value 150 is sufficient for typical applications. Larger beta value get larger sound but may have the amplified waveform saturated.

8 ohm speaker is recommended. The speaker characteristics and housing impacts the loudness very much.

Vout1, Vout2

They are tristate during standby state.

These two pins can drive buzzer directly. The piezo buzzer used should have its resonant frequency at the center of your sound frequency domain or you are unable to play your sound good by this buzzer.

For instance, you have your sound spans over frequency from 100 Hz through 1 KHz. A buzzer with resonant frequency at 300 Hz will play this sound good. A buzzer with resonant frequency at 1 KHz will distort the sound very much because that most of the energy of the playback sound is unable to be played by this buzzer.

TG0, TG1, TG2, TG3, TG4, TG5, TG6

These 7 pins have 4 ways to perform.

The 1st way (KBD addressing 1):

When user defines less than 11 sentences, a Vss pulse wider than t T applied to TG0 plays sentence 2, TG1 plays sentence 3,..., TG6 plays sentence 8. Of course, the fabrication should be masked as Keyboard addressing.

The 2nd way (KBD addressing 2):

When user defines more than 10 sentences, he can access the first ten sentences by way 1st. To access the 11st sentence or higher, these 7 pins are played as the S-tree. TG6 means 8, TG5 means 7, ..., TG0 means 2. Of course, the fabrication should be masked as Keyboard addressing.

The 3rd way (Matrix addressing):

To cooperate with TG7 as well as 7 ROWn pins

(ROW0 through ROW6), they form an 8x7 matrix in 56 cross points. The touch of a cross point activates a trigger signal to play respectively sentence. Of course, the fabrication should be masked as matrix addressing.

The 4th way (CPU addressing):

They are 7-bit high-true addresses to specify the section to be played among 128. TG6 is the MSB while TG0 is the LSB. They should meet the address hold time required, t H. Of course, the fabrication should be masked as cpu addressing.

TG7

This pin has 4 ways to perform.

The 1st way (KBD addressing 1):

When user defines less than 11 sentences, a Vss pulse wider than t T applied to TG7 plays sentence 9. Of course, the fabrication should be masked as Keyboard addressing.

The 2nd way (KBD addressing 2):

When user defines more than 10 sentences, he can access the first ten sentences by way 1st. To access the 11st sentence or higher, this TG7 means number 9 of S-tree. Of course, the fabrication should be masked as Keyboard addressing.

The 3rd way (Matrix addressing):

To cooperate with 7 TGn pins (TG0 through TG6) as well as 7 ROWn pins (ROW0 through ROW6), they form an 8x7 matrix in 56 cross points. The touch of a cross point activates a trigger signal to play respectively sentence. Of course, the fabrication should be masked as matrix addressing.

The 4th way (CPU addressing):

Address Strobe.

Its rising edge latches the 7-bit addresses and starts the playing. Its falling edge stops immediately the playing sound, activates (or keeps) the busy output to be high, activates the audio output to stay at center value, activates the LED output. Its width should be wide enough as t W. Of course, the fabrication should be masked as cpu addressing.

ROW0, 1, 2, 3, 4, 5, 6

These 7 pins have 3 ways to perform.

The 1st way (KBD addressing 1):

When user defines less than 11 sentences, a Vss pulse wider than t T applied to ROW6 plays sentence 1, ROW5 plays sentence 0. Of course, the fabrication should be masked as Keyboard addressing.

The 2nd way (KBD addressing 2):

When user defines more than 10 sentences, of

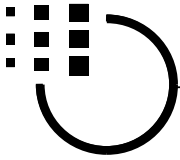

course he can access the first ten sentences by way 1st. To access the 11st sentence or higher, these 5 pins (ROW0 through ROW4) are played as the D-tree. ROW5 and ROW6 are played as S-tree. ROW6 means 1, ROW5 means zero. ROW4 means 40, ROW3 means 30, ..., ROW0 means 0. Of course, the fabrication should be masked as KeyBoard addressing.

The 3rd way (Matrix addressing):

To cooperate with TG7 as well as 7 TGn pins (TG0 through TG6), they form an 8x7 matrix in 56 cross points. The touch of a cross point activates a trigger signal to play respectively sentence.

Of course, the fabrication should be masked as matrix addressing.

Rosc

This is a pin to provided bias to activate built in VCO circuit. A 1200 K ohm resistor serial from Vdd (3.0V) to this pin can play the audio output at 6 KHz sample rate. Larger Rosc plays lower frequency.

LED

This is an output pin which can flash an LED lamp at Fix 6 Hz in a sink type by I led. Fix 6 Hz flash means this pin turns LED lamp on for 83 ms and then turns it off for 83 ms alternately.

	filename of S6605's	filename of S4305's	filename of S3205's	filename of S2105's	Functions
1	S6605QA	S4305QA	S3205QA	S2105QA	to define 128 word sections
2	S6605QE	S4305QE	S3205QE	S2105QE	to define 64 sentence tables

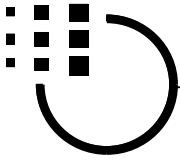

Terms

Retrigger Trigger

Retriggerable Trigger-m means the sentence-m addressed by Trigger-m could be retriggered by other Triggers. It can be retriggered by itself.

Cycle Loop

It is determined automatically by the sentences user defined at fabrication.

Continue OKY & Home OKY

This is a function belongs to OKY and determines the play sequence when the first OKY comes after any other trigger addressing. The "continue" preserves the sequence while the "home"rewinds to the very beginning. You will see a term S.W.A.I. in this data sheet, it means sequence when after interrupt by other trigger addressing.

Smample Rate

There are some parameters are sample rate dependent. They are debounce time, LED fix flash frequency and Stop pulse width. The numbers mentioned in this data sheet are based on 6 KHz sample rate typically, but just typical. Smaller Rosc playback quicker - higher pixel rate. MVI provides voice chip with very flat response for playback vs working voltage. Higher working voltage get slower playback but insignificantly.

Stop Pulse

Stop pulse is one of Status definition. This Stop pulse is not guaranteed when user defines the trigger behavior as Holdable.

Key Priority

The key priority defines which trigger is to be acknowledged when two or more triggers are being activated. For both KeyBoard and Matrix addressing modes, no key priority is guaranteed. It means when playing a sound, only one key is promised, further triggers is not guaranteed until when this sentence is accomplished and trigger is released.

Application Notes

To play words concatenated

To play two words concatenated at cpu addressing mode, cpu should take care during the interval in between. When detecting the busy signal falls to low, the next word had better to start in within t PL. Because during this t PL interval, the Cout sounds silent but keeps at the center of full scale. The former word starts within t PL interval will start smoothly without abrupt potential change on current through speaker.

Longer than the t PL interval the Cout begins ramp down interval, it is recommended to not start the former word. It does not sound bad, but ramp up starts at the ramp down interval is not preferred.

Parallel chips

Parallel chips share a speaker is not recommended at cpu addressing mode. Please don't use this solution. MVI offers 120" chip to replace this parallel chips solution.

When user insists to adopt this solution due to no alternate, the cpu should take care when playing two words simultaneously or concatenated from two respective chips. As described, the silence hears nothing on speaker but there is signal potential appears on Cout output pin.

There are four occurrences to have potential signal on Cout but you hear nothing. With Two sources both have any one of above occurrences, the summation will cause particular signal output and even noise. These four occurrences are (1) silence from ramp up (2) silence from ramp down (3) silence from at middle data value either in-between sound or in interval t PL (4) silence from appendec memory-less mute.

To left sentence empty

User may not define every sentence. But every sentence accessed by OKY must be defined, cannot be empty. This kind of mis-use always happens when customer define several not concatenated sentences under matrix addressing mode. At this time, OKY is not allowed to access or the error may occur due to there is empty sentence.

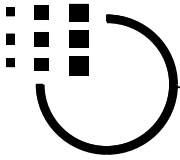

Addressing Reference

	KeyBoard	CPU	Matrix
TG7	S=9	Strobe	T=7
TG6	S=8	A6, MSB	T=6
TG5	S=7	A5	T=5
TG4	S=6	A4	T=4
TG3	S=5	A3	T=3
TG2	S=4	A2	T=2
TG1	S=3	A1	T=1
TG0	S=2	A0	T=0
ROW6	S=1	X	R=6
ROW5	S=0	X	R=5
ROW4	D=40	X	R=4
ROW3	D=30	X	R=3
ROW2	D=20	X	R=2
ROW1	D=10	X	R=1
ROW0	D=0	X	R=0
To play	D+S	binary (A6543210)	8 x R + T
	sentence	section	sentence

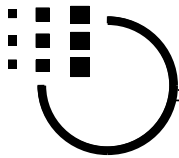

DC Characteristics at 3.0 Vdd (S6605)

Symbol	Parameter	Valid	Min.	Typ.	Max.
I _{sb}	Standby I	Vdd	—	—	1
I _{op}	Operation I	Vdd	—	100	300
I _{iht}	input high I	TG0-7	—	—	1
I _{iLT}	input low I	TG0-7	—	5	
I _{ihr}	input high I	ROW0-6	—	—	1
I _{iLr}	input low I	ROW0-6	—	5	—
I _{ohr}	output high I	ROW0-6	—	-5	—
I _{oLr}	output low I	ROW0-6	—	5	—
I _{ohbs}	output high I	BS	—	-3.5	—
I _{oLbs}	output low V	BS	—	3.5	
I _{led}	LED sink I	LED	—	9	
I _{ohv}	output high I	Vout1,2	—	-6	-7
I _{oLv}	output low I	Vout1,2	—	+6	+7
I _{co}	current o/p V	Cout	—	-2.5	
V _{co}	current o/p V	Cout			
V _{ohv}	output high V	Vout1			
V _{oLv}	output low V	Vout2			
R ₁	Oscillation R	Rosc	—	1.1	
R ₁	Oscillation R	Rosc	—	840	
R _{cds}	cds R		—	—	80
R _{cnt}	Switch contact R		—	—	20
d _{F/F}	Frq. stability		-5	—	5
d _{F/F}	Frq. variation		-10	—	10

Symbol	Parameter	Valid	Min.	Typ.	
I _{sb}	Standby I	Vdd	—	—	
I _{op}	Operation I	Vdd	—	150	
I _{iht}	input high I	TG0-7	—	—	
I _{iLT}	input low I	TG0-7	—	10	
I _{ihr}	input high I	ROW0-6	—	—	
I _{iLr}	input low I	ROW0-6	—	10	
I _{ohr}	output high I	ROW0-6	—	-10	
I _{oLr}	output low I	ROW0-6	—	10	
I _{ohbs}	output high I	BS	—	-8	
I _{oLbs}	output low V	BS	—	8	
I _{led}	LED sink I	LED	—	10	
I _{ohv}	output high I	Vout1,2	—	-13	
I _{oLv}	output low I	Vout1,2	—	+13	
I _{co}	current o/p V	Cout	—	-3.5	
V _{co}	current o/p V	Cout			
V _{ohv}	output high V	Vout1			
V _{oLv}	output low V	Vout2			
R ₁	Oscillation R	Rosc	—	1.2	
R ₁	Oscillation R	Rosc	—	860	

Specifications subject to change without notice, contact your sales representatives for the most recent information.

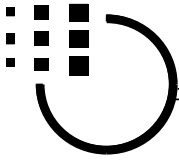

R cds	cds R		—	—	40	Kohm	
R cnt	Switch contact R		—	—	20	Kohm	
d F/F	Frq. stability		-5	—	5	%	[F(4.5V)-F(4.0V)] /F(4.5V)
d F/F	Frq. variation		-10	—	10	%	lot by lot

AC Characteristics at 4.5 V & 6000 Hz S.R.

Symbol	Description	Valid	Min.	Typ.	Max.	Unit	Remarks
t T	Trigger pulse width	MTX, KB	21			ms	SRD & MO
t H	Trigger address hold time	CPU	80			ns	SRD
t W	Write enable pulse width	CPU	40			us	SRD
t WA	TG7 rise to audio start	CPU		500		us	SRD
t BS	Lag between busy & stop	CPU, MTX, KB		0		ms	SRD
t TB	Lag between trig & busy	MTX, KB		20		ms	SRD
t PL	plain width behind sound	CPU, MTX, KB		40		ms	SRD
t RMU	Ramp up width	CPU, MTX, KB		20		ms	SRD
t RMD	Ramp down width	CPU, MTX, KB		20		ms	SRD
t STP	Stop pulse width	CPU, MTX, KB		80		ms	SRD & MO
t SET	address set up time	CPU	40			us	SRD
t WLR	write fall to ramp up start	CPU		0		us	SRD
t WLB	write fall to busy start	CPU		0		us	SRD
t WLA	write fall to audio stop	CPU	0			us	SRD
t P	Power rise up time	Vdd			1	ms	
t R	Power ripple width	Vdd			1	ms	

SRD:=Sample rate dependent; MO:=Mask optional

Standard Code Line Up

To be Available Soon

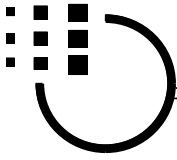

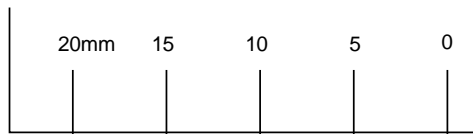

COB Information

Silk screen & copper print
COB model number P48



Legend

-  Copper pad
-  Chip covered

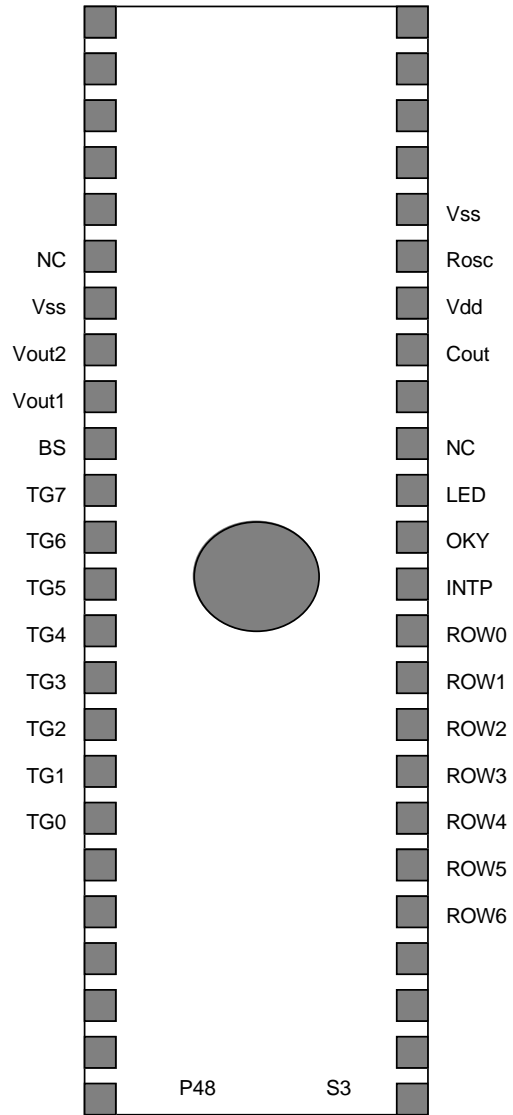

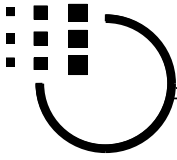

Timing Critical

I. Acceptable Power On Signal & Ripple

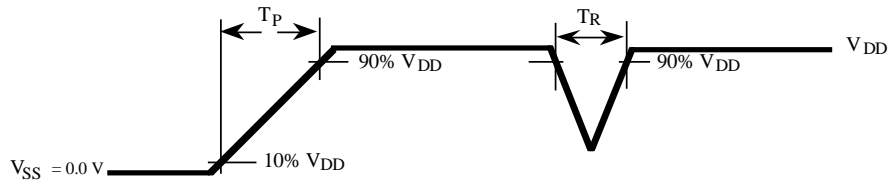

II. To play a voice sound

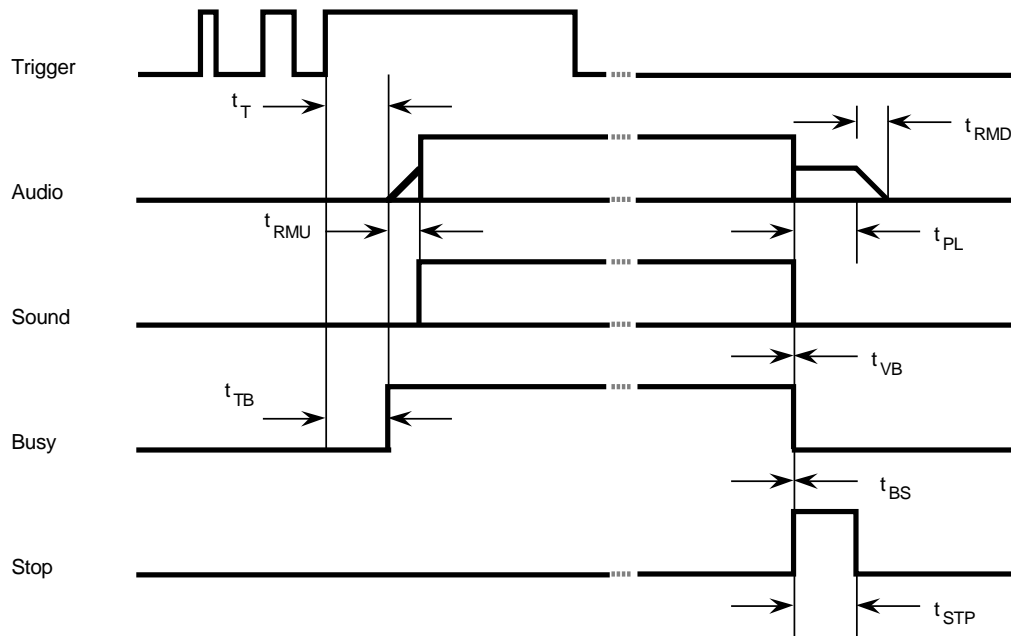

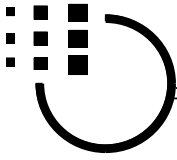

III. To stop a playing sound by TG7 at C.A. mode at retriggerable mask

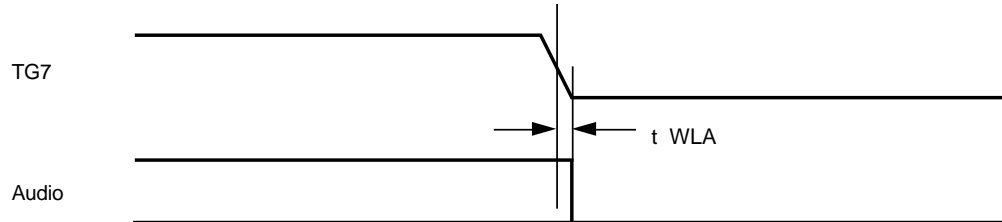

IV. To start a specific sound at C.A. mode

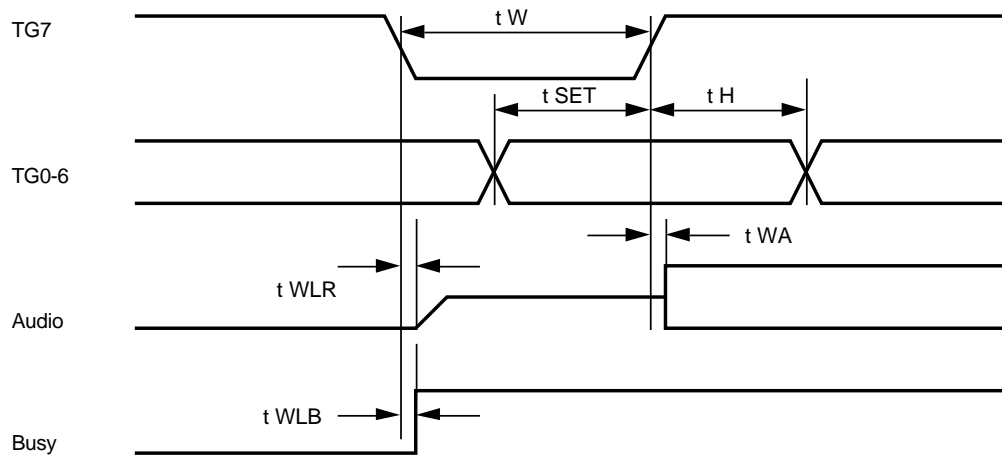

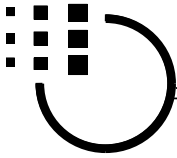

Timing Diagram

I.1. Edge mask / Unholdable output / Matrix mode

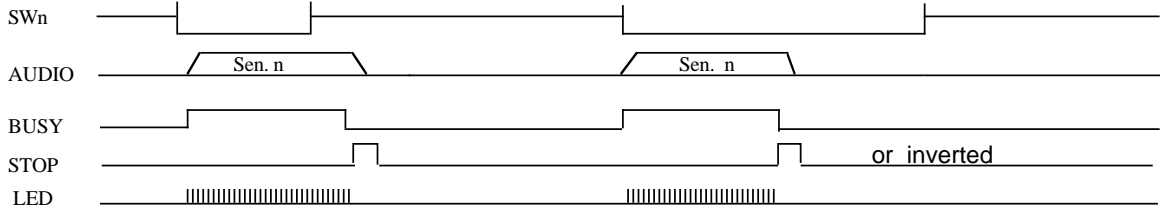

I.2. Level mask / Unholdable output / Matrix mode

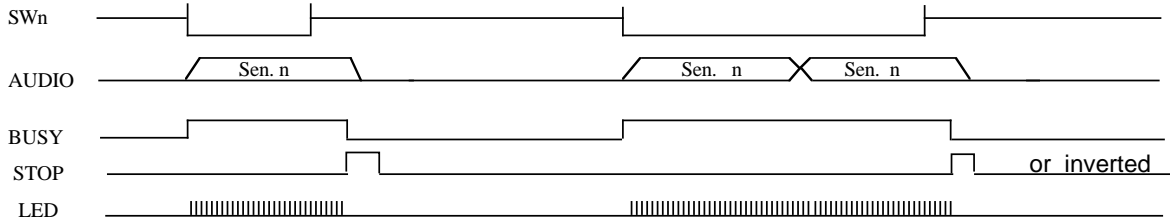

II.1. Edge mask/ Unholdable output / KeyBoard mode

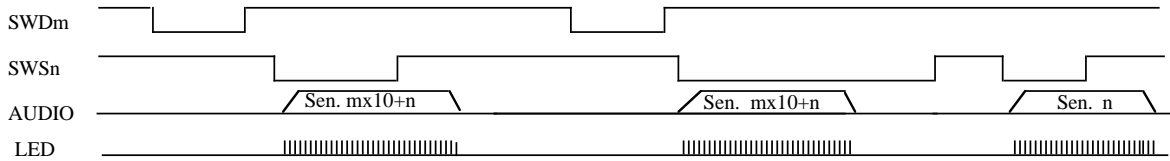

II.2. Level mask/ Unholdable output / KeyBoard mode



II.3. Edge Mask/ Unholdable output / Matrix mode

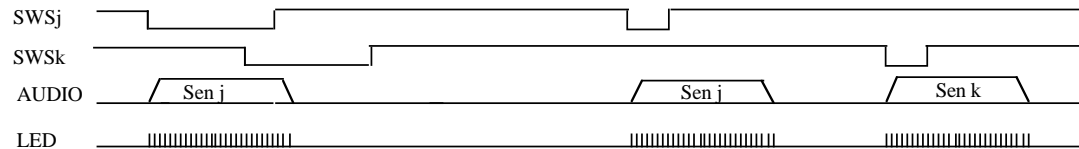

III.1. Mask as Retrigger type / both MTX and KBD modes

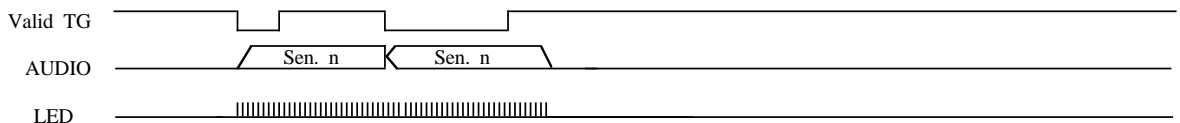

Specifications subject to change without notice, contact your sales representatives for the most recent information.

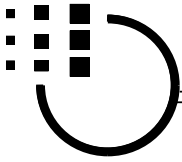

III.2. Mask as Irretrigger type / Both MTX and KBD modes

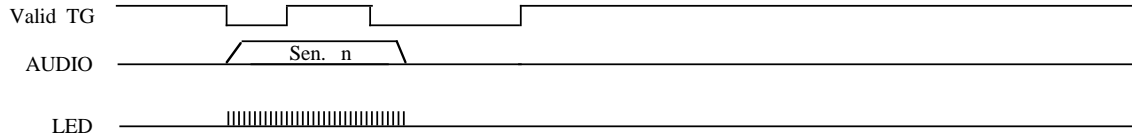

IV. Interrupt Pin Function / 3 addressing modes < condition assumed: Edge mask & Unholdable O/P >

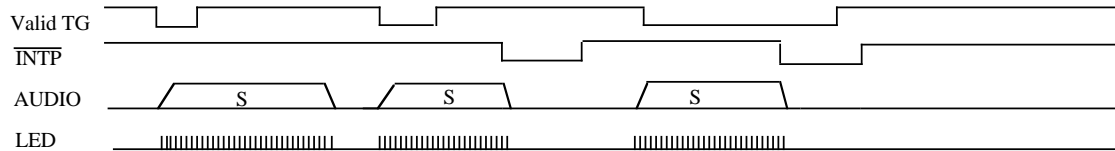

V.1. Level mask / Holdable output / both MTX and KBD modes

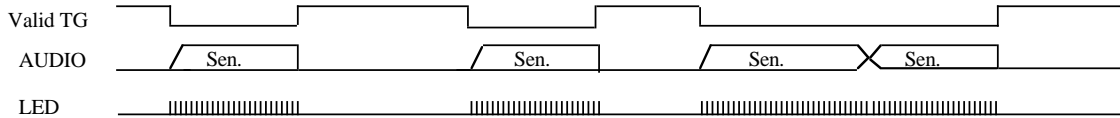

V.2. Edge mask / Holdable output / both MTX and KBD modes

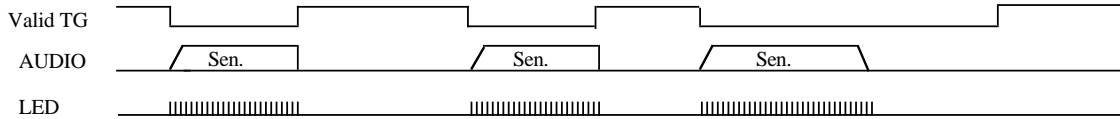

VI.1. Edge mask / Playall / 3 addressing modes < assumed condition : 4 sentences total >

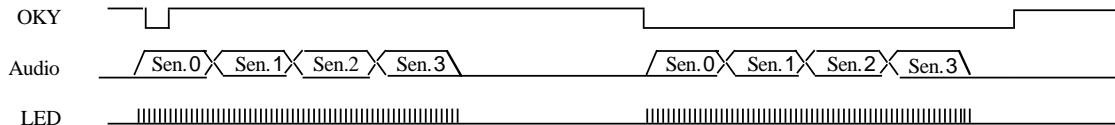

VI.2. Level mask / Playall / 3 addressing modes < assumed condition : 4 sentences total >

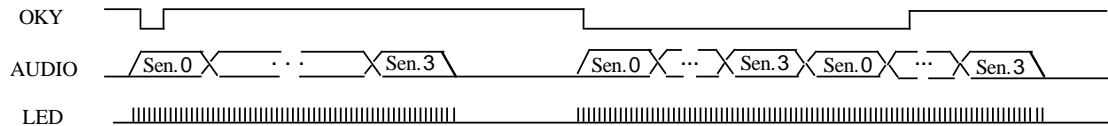

VII.1. Edge mask / Unholdable output / Randomplay / 3 addressing modes

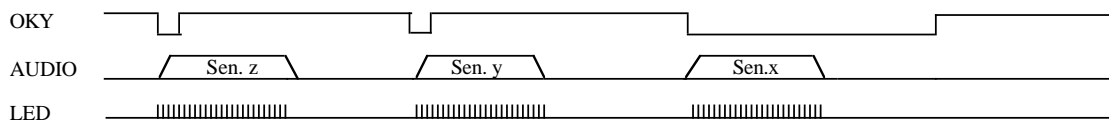

VII.2. Level mask / Unholdable output / Randomplay / 3 addressing modes

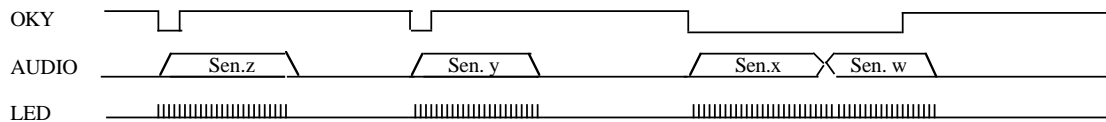

Sen = Sentence , S = Sentence or Section

Specifications subject to change without notice, contact your sales representatives for the most recent information.

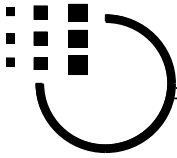

VIII.1. Edge mask / Continue-playnext / 3 addressing modes

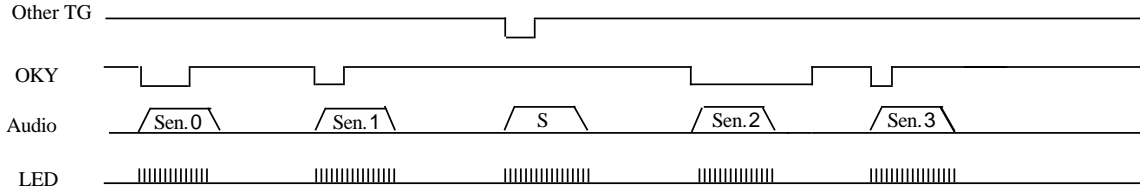

VIII.2. Level mask / Continue-playnext / 3 addressing modes

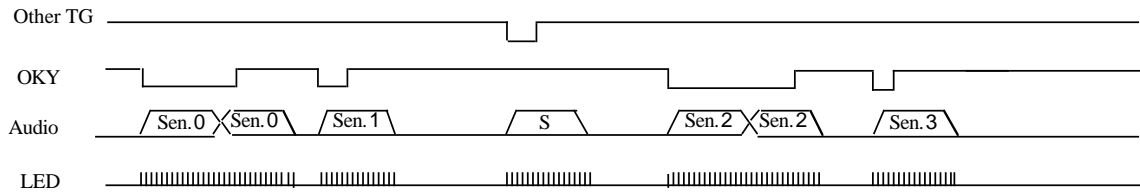

VIII.3. Edge mask / Home-playnext / 3 addressing modes

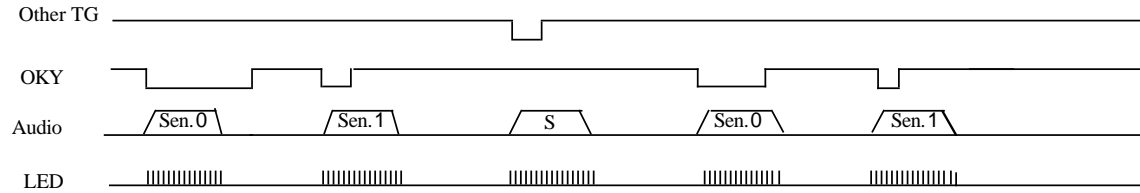

VIII.4. Level mask / Home-playnext / 3 addressing modes

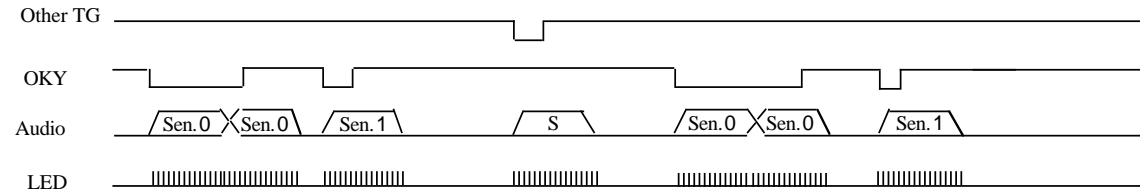

IX. 1. CPU addressing mode

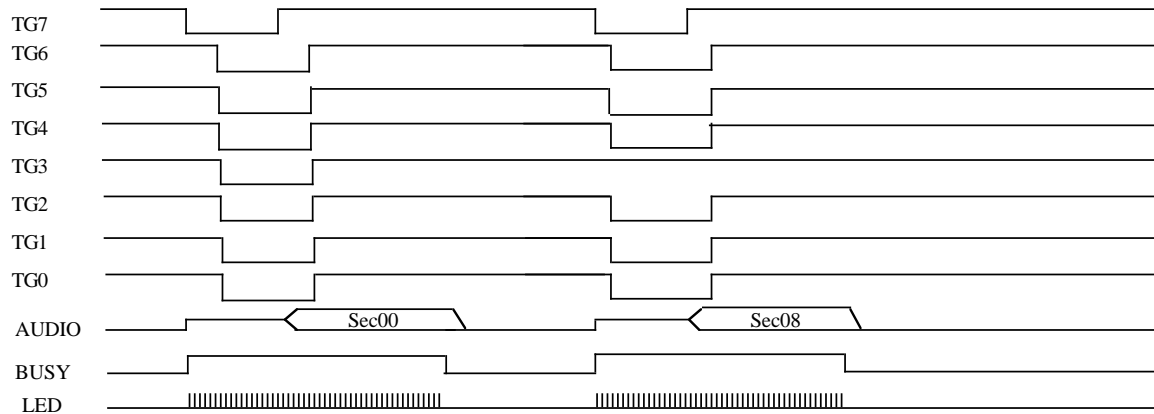

Specifications subject to change without notice, contact your sales representatives for the most recent information.

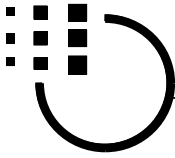

IX. 2. Mask as Retrigger type/ CPU mode

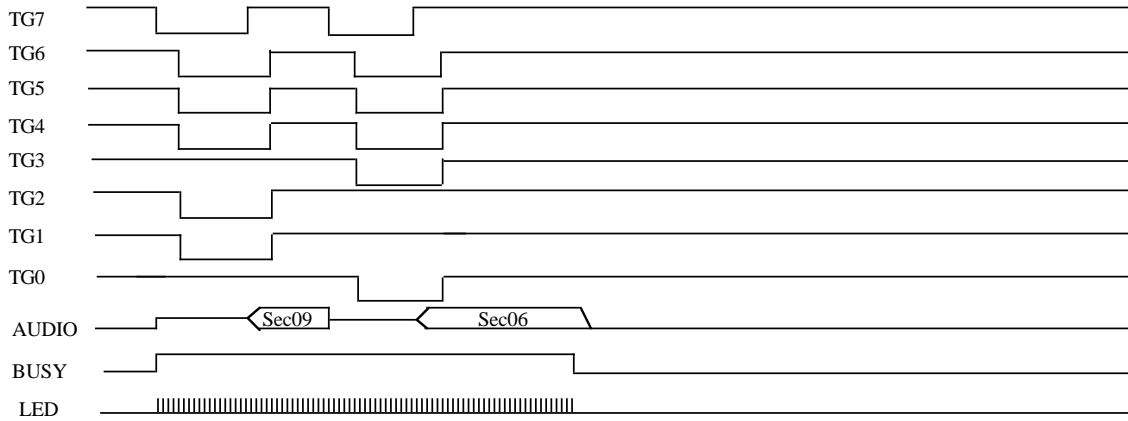

Application Circuit

Typical Application

1. CPU addressing

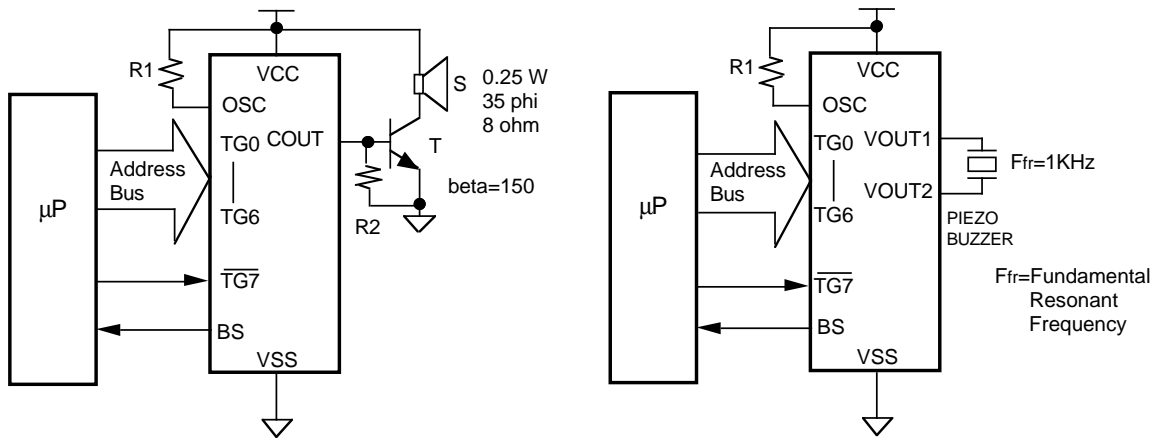

Specifications subject to change without notice, contact your sales representatives for the most recent information.

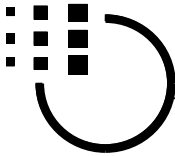

2. KeyBoard addressing(>10 sentence):

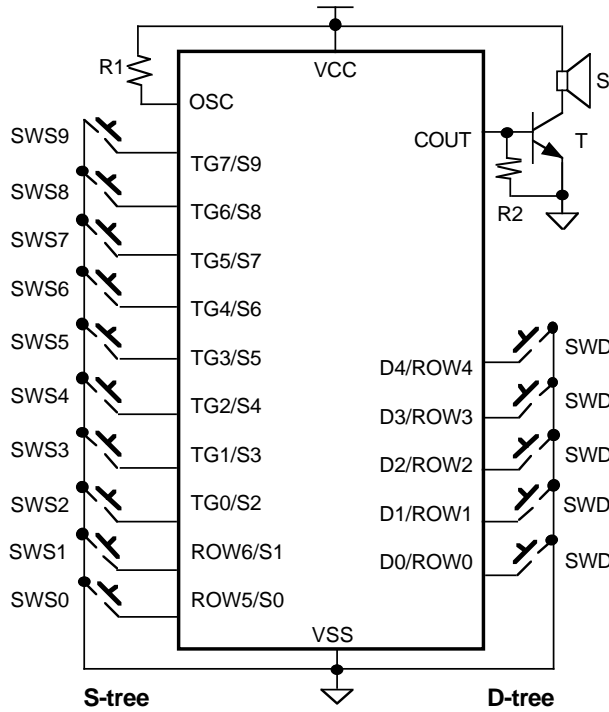

3. KeyBoard addressing (≤10 sentence):

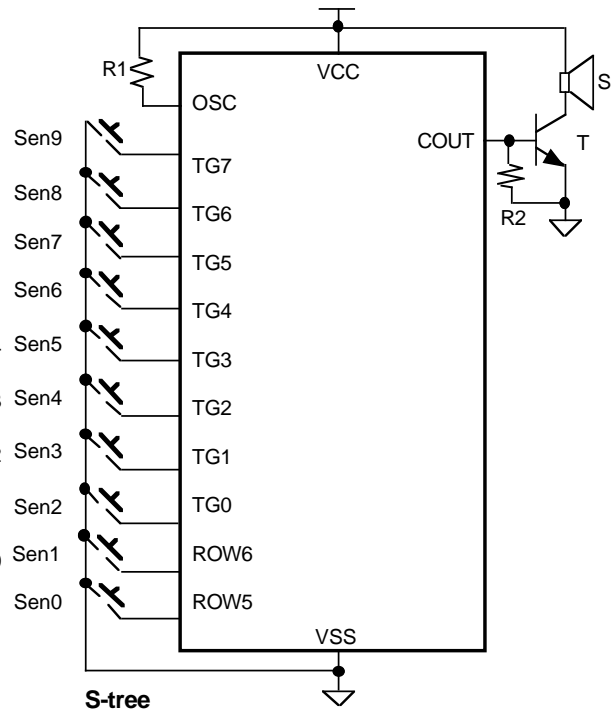

4. Matrix addressing Mode:

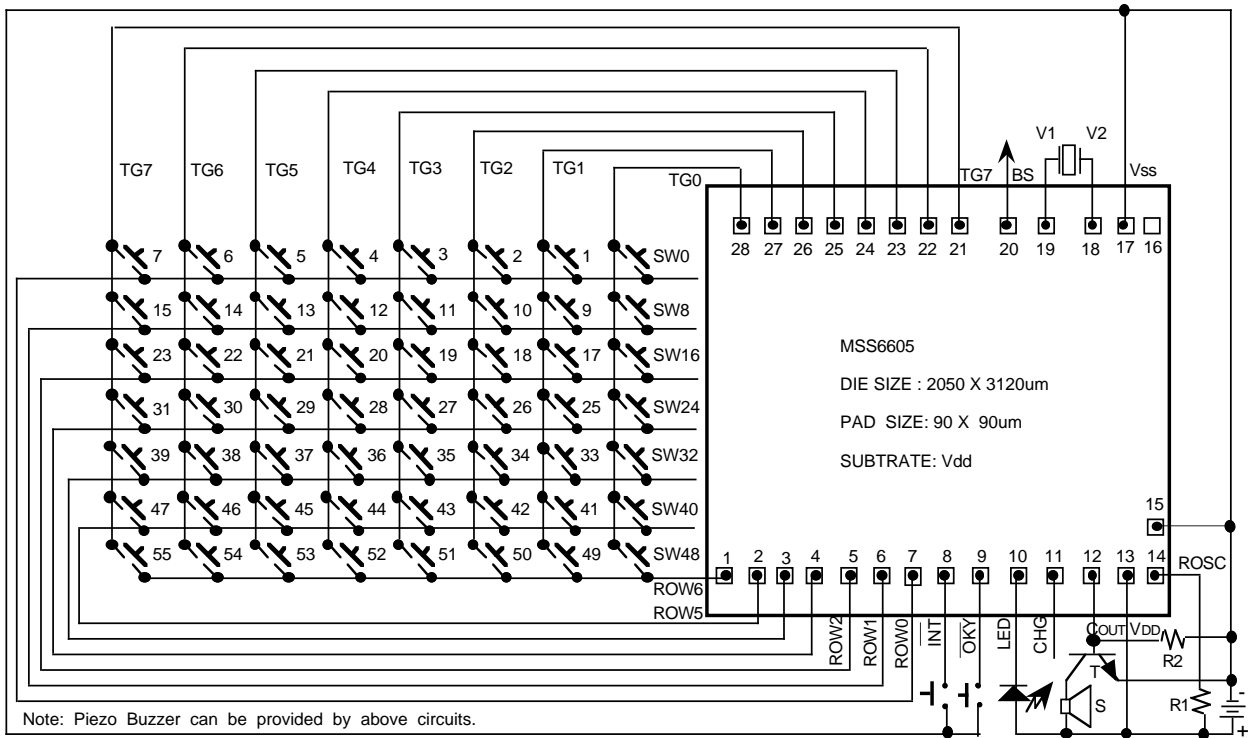

Specifications subject to change without notice, contact your sales representatives for the most recent information.

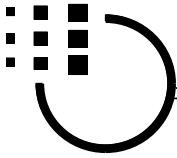

5. WORK AS MTX addressing Mode:

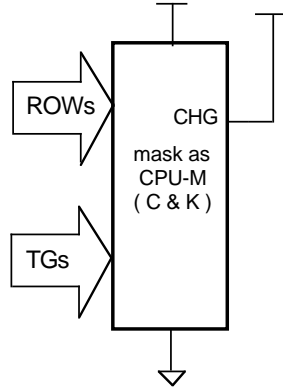
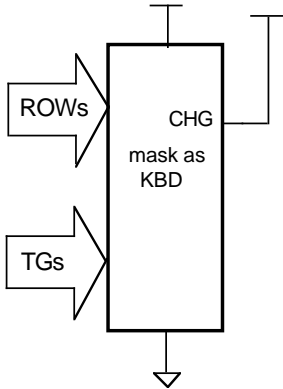

6. WORK AS KBD addressing Mode:

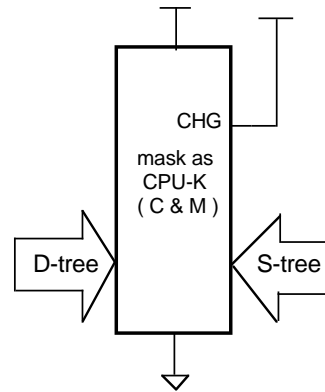
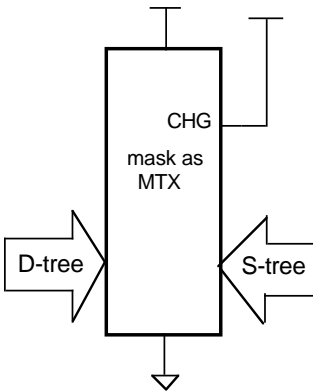

7. Circuit to drive operational amplifier:

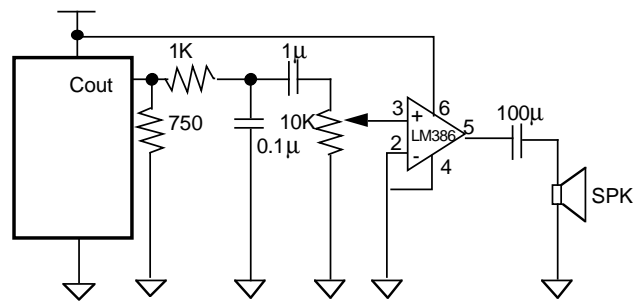
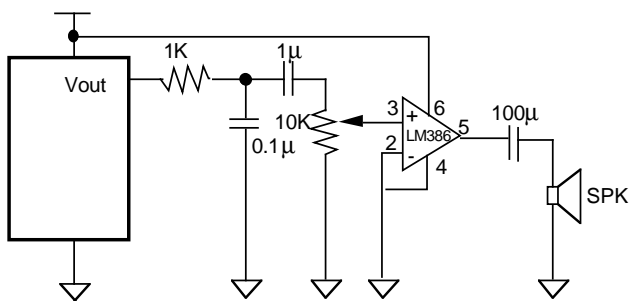

Note: The outline of application circuits described herein is chosen as an example and illustration to the product. Please ensure the outside conditions in real manufacturing are reflected in your design.

Specifications subject to change without notice, contact your sales representatives for the most recent information.

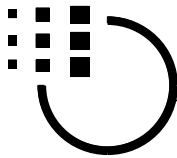

Bonding Diagram

ORDER	PAD-NAME	X-COORE	Y-COORD	ORDER	PAD-NAME	X-COORE	Y-COORE
2	ROW5	-773	-1456	16	NC	913	1456
3	ROW4	-641	-1456	17	GND	776	1456
4	ROW3	-509	-1456	18	VOUT2	650	1456
5	ROW2	-377	-1456	19	VOUT1	464	1456
6	ROW1	-245	-1456	20	BS	334	1456
7	ROW0	-113	-1456	21	TG7	198	1456
8	INT	41	-1456	22	TG6	43	1456
9	OKY	195	-1456	23	TG5	-111	1456
10	LED	379	-1456	24	TG4	-265	1456
11	CHG	517	-1456	25	TG3	-420	1456
12	COUT	649	-1456	26	TG2	-574	1456
13	VDD	794	-1456	27	TG1	-729	1456
14	ROSC	920	-1456	28	TG0	-883	1456
15	GND	920	-1274	1	ROW6	-905	-1456

Taiwan
 #1, Creation Road I,
 Science - based Industrial Park,
 Hsinchu, 30077
 Taiwan, ROC
 "taylor_hsiao@ccmail.mosel.com.tw"
 TEL: 886-3-5770055
 FAX: 886-3-5772788
 FAX: 886-3-5784732

Taipei
 7F, #102 Sec. 3,
 Ming Chung E. Road,
 Taipei
 Taiwan, ROC
 TEL: 886-2-5451213
 FAX: 886-2-5451214

Hongkong
 #19 Dai Fu Street,
 Taipo Industrial Estate,
 Taipo, N.T.
 Hongkong
 TEL: 852-2388-2777(MKO)
 TEL: 852-2665-4883
 FAX: 852-2664-2406
 FAX: 852-2770-8011(MKO)

U.S.A.
 #3910 North First Street,
 San Jose,
 CA. 65134-1501
 U.S.A.
 TEL: 1-408-433-6000
 FAX: 1-408-433-0952

Specifications subject to change without notice, contact your sales representatives for the most recent information.

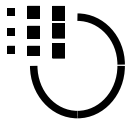

To : Mosel Vitelic Inc. 886-3-5772788 (fax)

TITLE []

Attn : Sales & Marketing Department

Product Request Form

We hereby request MVI to start preparing produce MSS6605 which is specified as below description as well as form A. We already read this data sheet PID 248*** and understand MSS6605 completely and know how to specify to fit my requirement. Its voice storage limitation is 55500h.

General Descriptions / Chip descriptions table with fields for Customer, Agent, Sales, Providing to MVI, Service Required, Matrix/Keyboard addressing mode, etc.

- Form C is attached due to more than 64 words defined.
Form E is attached due to some sentences defined and not adopt CPU addressing mode.
Form F is attached due to more than 32 sentences defined and not adopt CPU addressing mode.

Company Name : _____ Fax number : _____

Signature : _____ Date : _____

Department/Section : _____ Position Title : _____

Specifications subject to change without notice, contact your sales representatives for the most recent information.

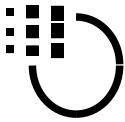

To : Mosel Vitelic Inc. 886-3-5772788 (fax)

TITLE	
--------------	--

Attn : Sales & Marketing Department

Product Request Form

We hereby request MVI to start preparing produce MSS4305 which is specified as below description as well as form A. We already read this data sheet PID 248*** and understand MSS4305 completely and know how to specify to fit my requirement. Its voice storage limitation is 40000h.

General Descriptions		Chip descriptions	
Customer	No proceed if empty	<input type="checkbox"/> Matrix addressing	Title
Agent		<input type="checkbox"/> KeyBoard addressing	SampleRate
Sales	Who is MVI sales you contact ?	<input type="checkbox"/> CPU addressing	Output
Repr'tives		<input type="checkbox"/> CPU & Matrix	Device
Providing to MVI	<input type="checkbox"/> 8-bit PCM sound files <input type="checkbox"/> .WAV sound files <input type="checkbox"/> DAT or equivalent <input type="checkbox"/> something special in written memo <input type="checkbox"/> Others _____	<input type="checkbox"/> CPU & KeyBoard	<input type="checkbox"/> Buzzer (F fr =1KHz) <input type="checkbox"/> Speaker (0.25W, 8 ohm, 1" diam.) <input type="checkbox"/> Other: _____
Service Required from MVI		<input type="checkbox"/> No use & don't care	
	<input type="checkbox"/> EPROMs with data inside <input type="checkbox"/> files to be programmed into EPROM <input type="checkbox"/> 9009 emulation board & EPROM <input type="checkbox"/> Confirm table <input type="checkbox"/> Others _____	<input type="checkbox"/> Stop low pulse, 40 mS	<input type="checkbox"/> 2.5 V <input type="checkbox"/> 5.0 V <input type="checkbox"/> 3.0 V <input type="checkbox"/> 5.5 V <input type="checkbox"/> 3.5 V <input type="checkbox"/> 6.0 V <input type="checkbox"/> 4.0 V <input type="checkbox"/> 4.5 V
		<input type="checkbox"/> Stop low pulse, 5 mS	
		<input type="checkbox"/> Stop high pulse, 40 mS	<input type="checkbox"/> Battery its size = _____ <input type="checkbox"/> Mains <input type="checkbox"/> Other _____
		<input type="checkbox"/> Stop high pulse, 5 mS	
		<input type="checkbox"/> Busy	<input type="checkbox"/> Retrigger <input type="checkbox"/> Irretrigger <input type="checkbox"/> Don't care
		<input type="checkbox"/> No use and don't care	
		<input type="checkbox"/> Random play OKY	
		<input type="checkbox"/> Play all OKY	
		<input type="checkbox"/> Play next OKY / continue	
		<input type="checkbox"/> Play next OKY / home	
		<input type="checkbox"/> Play next OKY	
		<input type="checkbox"/> No use & don't care	
Specify below Mask information whenever using either Matrix or KeyBoard addressing mode			
<input type="checkbox"/> Level	<input type="checkbox"/> Hold	<input type="checkbox"/> 20 mS debounce	
<input type="checkbox"/> Edge	<input type="checkbox"/> Unhold	<input type="checkbox"/> 5 mS debounce	
<input type="checkbox"/> Don't care	<input type="checkbox"/> Don't care	<input type="checkbox"/> Don't care	

- Form C is attached due to more than 64 words defined.
- Form E is attached due to some sentences defined and not adopt CPU addressing mode.
- Form F is attached due to more than 32 sentences defined and not adopt CPU addressing mode.

Company Name : _____ Fax number : _____

Signature : _____ Date : _____

Department/Section : _____ Position Title : _____

Specifications subject to change without notice, contact your sales representatives for the most recent information.

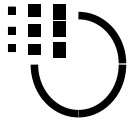

To : Mosel Vitelic Inc. 886-3-5772788 (fax)

TITLE

Attn : Sales & Marketing Department

Product Request Form

We hereby request MVI to start preparing produce MSS3205 which is specified as below description as well as form A. We already read this data sheet PID 248*** and understand MSS3205 completely and know how to specify to fit my requirement. Its voice storage limitation is 30000h.

General Descriptions / Chip descriptions table with fields for Customer, Agent, Sales, Repr'tives, Providing to MVI, Service Required from MVI, Matrix/Keyboard addressing, Title, SampleRate, Output Device, Working Voltage, Power Source, Level, Edge, Don't care, Hold, Unhold, Don't care, 20 mS debounce, 5 mS debounce, Don't care.

- Form C is attached due to more than 64 words defined.
Form E is attached due to some sentences defined and not adopt CPU addressing mode.
Form F is attached due to more than 32 sentences defined and not adopt CPU addressing mode.

Company Name : Fax number :

Signature : Date :

Department/Section : Position Title :

Specifications subject to change without notice, contact your sales representatives for the most recent information.

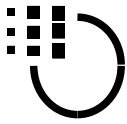

To : Mosel Vitelic Inc. 886-3-5772788 (fax)

TITLE

Attn : Sales & Marketing Department

Product Request Form

We hereby request MVI to start preparing produce MSS2105 which is specified as below description as well as form A. We already read this data sheet PID 248*** and understand MSS2105 completely and know how to specify to fit my requirement. Its voice storage limitation is 20000h.

General Descriptions / Chip descriptions table with fields for Customer, Agent, Sales, Providing to MVI, Service Required, Matrix/Keyboard addressing mode, etc.

- Form C is attached due to more than 64 words defined.
Form E is attached due to some sentences defined and not adopt CPU addressing mode.
Form F is attached due to more than 32 sentences defined and not adopt CPU addressing mode.

Company Name : _____ Fax number : _____

Signature : _____ Date : _____

Department/Section : _____ Position Title : _____

Specifications subject to change without notice, contact your sales representatives for the most recent information.

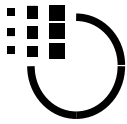

Product Request Form A : Voice Word Definitions

TITLE

There are 1 ≤ ≤64 words defined on this form.

Address	Voice Description	VoiceLength	MuteLength	WordTotal ≤ 80000h
00 00h		S 00h	S 00h	00h
01 01h		S 00h	S 00h	00h
02 02h		S 00h	S 00h	00h
03 03h		S 00h	S 00h	00h
04 04h		S 00h	S 00h	00h
05 05h		S 00h	S 00h	00h
06 06h		S 00h	S 00h	00h
07 07h		S 00h	S 00h	00h
08 08h		S 00h	S 00h	00h
09 09h		S 00h	S 00h	00h
10 0Ah		S 00h	S 00h	00h
11 0Bh		S 00h	S 00h	00h
12 0Ch		S 00h	S 00h	00h
13 0Dh		S 00h	S 00h	00h
14 0Eh		S 00h	S 00h	00h
15 0Fh		S 00h	S 00h	00h
16 10h		S 00h	S 00h	00h
17 11h		S 00h	S 00h	00h
18 12h		S 00h	S 00h	00h
19 13h		S 00h	S 00h	00h
20 14h		S 00h	S 00h	00h
21 15h		S 00h	S 00h	00h
22 16h		S 00h	S 00h	00h
23 17h		S 00h	S 00h	00h
24 18h		S 00h	S 00h	00h
25 19h		S 00h	S 00h	00h
26 1Ah		S 00h	S 00h	00h
27 1Bh		S 00h	S 00h	00h
28 1Ch		S 00h	S 00h	00h
29 1Dh		S 00h	S 00h	00h
30 1Eh		S 00h	S 00h	00h
31 1Fh		S 00h	S 00h	00h
32 20h		S 00h	S 00h	00h
33 21h		S 00h	S 00h	00h
34 22h		S 00h	S 00h	00h
35 23h		S 00h	S 00h	00h
36 24h		S 00h	S 00h	00h
37 25h		S 00h	S 00h	00h
38 26h		S 00h	S 00h	00h
39 27h		S 00h	S 00h	00h
40 28h		S 00h	S 00h	00h
41 29h		S 00h	S 00h	00h
42 2Ah		S 00h	S 00h	00h
43 2Bh		S 00h	S 00h	00h
44 2Ch		S 00h	S 00h	00h
45 2Dh		S 00h	S 00h	00h
46 2Eh		S 00h	S 00h	00h
47 2Fh		S 00h	S 00h	00h
48 30h		S 00h	S 00h	00h
49 31h		S 00h	S 00h	00h
50 32h		S 00h	S 00h	00h
51 33h		S 00h	S 00h	00h
52 34h		S 00h	S 00h	00h
53 35h		S 00h	S 00h	00h
54 36h		S 00h	S 00h	00h
55 37h		S 00h	S 00h	00h
56 38h		S 00h	S 00h	00h
57 39h		S 00h	S 00h	00h
58 3Ah		S 00h	S 00h	00h
59 3Bh		S 00h	S 00h	00h
60 3Ch		S 00h	S 00h	00h
61 3Dh		S 00h	S 00h	00h
62 3Eh		S 00h	S 00h	00h
63 3Fh		S 00h	S 00h	00h

Length summation of above 64 words along with those on form C is 00h must be ≤ limit.

Signature & date MVI Sales & date

Specifications subject to change without notice, contact your sales representatives for the most recent information.

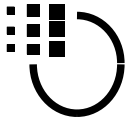

Product Request Form C : Voice Word Definitions

TITLE

There are 0 ≤ ≤64 words defined on this form.

Table with columns: Address, Voice Description, VoiceLength, MuteLength, WordTotal ≤ 80000h, and a grid of word definitions (e.g., 64 40h, 65 41h, ..., 127 7Fh).

Length summation of above 64 words is 00h has its limitation.

Signature & date MVI Sales & date

Specifications subject to change without notice, contact your sales representatives for the most recent information.

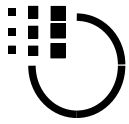

Product Request Form E : Sentence Table Definitions **TITLE**

MTX	KBD	OneKey	Sentence Definition (word section addresses)	Address count
R0T0	00	0		
R0T1	01	1		
R0T2	02	2		
R0T3	03	3		
R0T4	04	4		
R0T5	05	5		
R0T6	06	6		
R0T7	07	7		
R1T0	08	8		
R1T1	09	9		
R1T2	10	10		
R1T3	11	11		
R1T4	12	12		
R1T5	13	13		
R1T6	14	14		
R1T7	15	15		
R2T0	16	16		
R2T1	17	17		
R2T2	18	18		
R2T3	19	19		
R2T4	20	20		
R2T5	21	21		
R2T6	22	22		
R2T7	23	23		
R3T0	24	24		
R3T1	25	25		
R3T2	26	26		
R3T3	27	27		
R3T4	28	28		
R3T5	29	29		
R3T6	30	30		
R3T7	31	31		

There are 0 ≤ ≤ 32 sentences defined on this form E and their address entry sum'n along with those on form F is ≤ 256

Signature & date MVI Sales & date

Specifications subject to change without notice, contact your sales representatives for the most recent information.

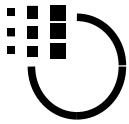

Product Request Form F : Sentence Table Definitions

TITLE

MTX	KBD	OneKey	Sentence Definition (word section addresses)	Address count
R4T0	32	32		
R4T1	33	33		
R4T2	34	34		
R4T3	35	35		
R4T4	36	36		
R4T5	37	37		
R4T6	38	38		
R4T7	39	39		
R5T0	40	40		
R5T1	41	41		
R5T2	42	42		
R5T3	43	43		
R5T4	44	44		
R5T5	45	45		
R5T6	46	46		
R5T7	47	47		
R6T0	48	48		
R6T1	49	49		
R6T2	NA	50		
R6T3	NA	51		
R6T4	NA	52		
R6T5	NA	53		
R6T6	NA	54		
R6T7	NA	55		
NA	NA	56		
NA	NA	57		
NA	NA	58		
NA	NA	59		
NA	NA	60		
NA	NA	61		
NA	NA	62		
NA	NA	63		

There are 0 ≤ ≤32 sentences defined on this form F and their address entry sum'n along with those on form E is written on it.

Signature & date MVI Sales & date

Specifications subject to change without notice, contact your sales representatives for the most recent information.