

## Current Mode PWM Controller

The DBL3842A is fixed PWM controller for Off-line and DC-DC converter applications. The internal circuits include UVLO, low start up current circuit, temperature compensated reference, highgain error amplifier, current sensing comparator, and high current totempole output for driving a power MOSFET. Also DBL3842A provide low start up current below 0.3 mA and short shutdown delay time typical 100nsec. DBL3842A have UVLO threshold of 16V(on) and 10V(off).

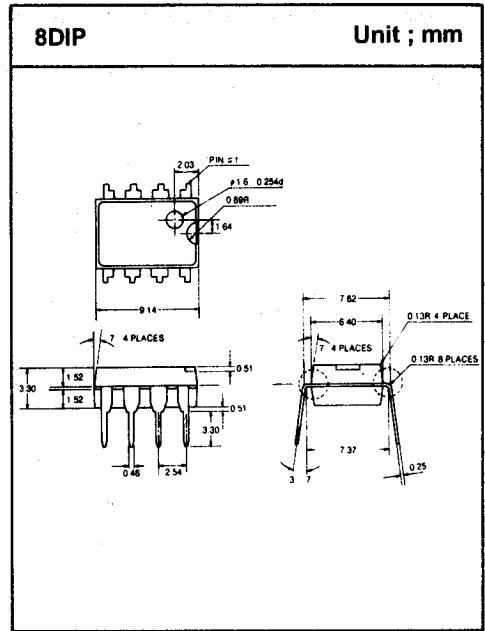

## FEATURES

- Low start up current < 0.3 mA
- Operating range up to 500 KHz
- Cycle by cycle current limiting
- Under Voltage Lock Out with hysteresis
- Short shutdown delay time ; typical 100nsec
- High current totempole output
- Output swing limiting : 22V

## BLOCK DIAGRAM

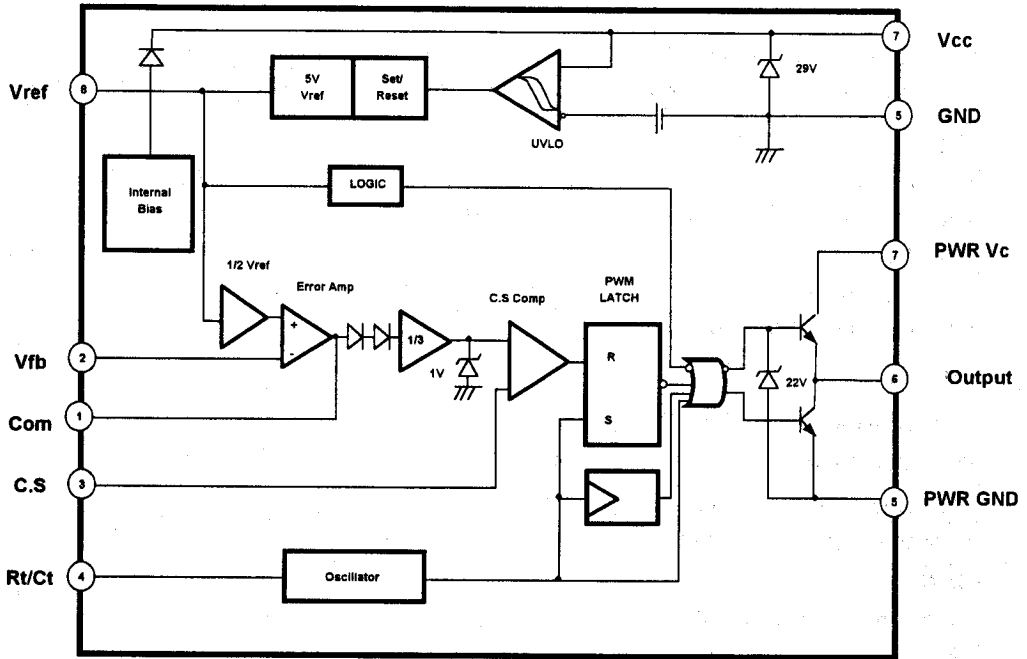

## ABSOLUTE MAXIMUM RATINGS

Characteristics	Symbol	Value	Unit
Supply Voltage	Vcc	28	V
Output Current	Io	1	A
Analog Inputs	Vi(ana)	-0.3 to 6.3	V
Error Amp. Output sink current	Isink(EA)	10	mA
Power Dissipation	Pd	1	W

## ELECTRICAL CHARACTERISTICS

(Vcc=15V, Rt=10Kohm, Ct=3.3nF, Ta=0°C to 70°C, Unless otherwise specified)

Charateristic	Symbol	Test Condition	MIN	TYP	MAX	UNIT
<b>REFERENCE SECTION</b>						
Output Voltage	Vref	Tj=25°C, Io=1mA	4.91	5.00	5.09	V
Line Regulation	$\Delta V_{ref}$	Vcc=12V to 25V	-	6	20	mV
Road Regulation	$\Delta V_{ref}$	Io= 1mA to 20mA	-	6	25	mV
Output Short current	Isc	Ta=25°C	-180	-100	-	mA
<b>OSCILLATOR SECTION</b>						
Initial Accuracy	Fosc	Tj=25°C	47	52	57	KHz
Voltage Stability	$\Delta f / \Delta V$	Vcc=12V to 25V	-	0.2	1.0	%
Oscillator Voltage	Vosc	Vpin4, Peak to Peak	1.4	1.7	1.8	V
Discharge Current	I <sub>discharge</sub>	Tj=25°C, Pin4=2V	7.8	8.3	8.8	mA
<b>CURRENT SENSE SECTION</b>						
GAIN	Gv		2.85	3.0	3.15	TIMES
Maximum Input Signal	Vi(max)	Vpin1=5V	0.9	1.0	1.1	V
PSRR	PSRR1	Vcc=12V to 25V	-	70	-	dB
Input Bias Current	I <sub>bias</sub>	-	-10	-2	-	uA
Delay to Output	Td	Vpin3=0V to 2V	-	100	200	ns
<b>ERROR AMPLIFIER SECTION</b>						
Input Voltage	V2	Vpin1=2.5V	2.42	2.50	2.58	V
Input Bias Current	I <sub>b</sub>	-	-2.0	-0.3	-	uA
Open Loop Gain	Avol	Vo=2V to 4V	65	90	-	dB
Unity Gain Bandwidth	GBW	Tj=25°C	0.7	1	-	MHz
PSRR	PSRR2	Vcc=12V to 25V	60	70	-	dB
Output Sink Current	I <sub>sink</sub>	Vpin2=2.7V, Vpin1=1.1V	2	6	-	mA
Output Source Current	I <sub>source</sub>	Vpin2=2.3V, Vpin1=5.0V	-	-0.8	-0.5	mA
Output High Voltage	VOH	Vpin2=2.3V, R1=15kΩ to GN	5	6	-	V
Output Low Voltage	VOL	Vpin2=2.3V, R1=15kΩ to Pin8	-	0.8	1.1	V

## ■ ELECTRICAL CHARACTERISTICS(Continued)

(V<sub>cc</sub>=15V, R<sub>t</sub>=10Kohm, C<sub>t</sub>=3.3nF, T<sub>a</sub>=0°C to 70°C, Unless otherwise specified)

OUTPUT SECTION						
Output Low Level1	VOL1	Isink= 20 mA	-	0.1	0.4	V
Output Low Level2	VOL2	Isink= 200 mA	-	1.5	2.0	V
Output High Level1	VOH1	Isource= 20 mA	13.0	13.5	-	V
Output High Level2	VOH2	Isource= 200 mA	12.0	13.5	-	V
Rise Time	Tr	T <sub>j</sub> =25°C, C <sub>1</sub> =1nF	-	40	100	ns
Fall Time	Tf	T <sub>j</sub> =25°C, C <sub>1</sub> =1nF	-	40	100	ns
Out Volt. Swing Limit	Volim	V <sub>cc</sub> =27V, C <sub>1</sub> =1nF	-	22	-	V
UNDER VOLTAGE LOCKOUT SECTION						
Start Threshold	Vth		15	16	17	V
Min. Operating Voltage	Vtl	After turn on	9	10	11	V
PWM SECTION						
Maximum Duty Cycle	Dmax		94	96	100	%
Minimum Duty Cycle	Dmin		-	-	0	%
TOTAL STANDBY CURRENT						
Start-Up Current	Ist	-	-	0.2	0.4	mA
Oper. Spply Current	Icc	V <sub>pin2</sub> =V <sub>pin3</sub> =0V	-	11	17	mA
V <sub>cc</sub> Zener Voltage	Vz	I <sub>cc</sub> =25mA	-	29	-	V

\* Adjust V<sub>cc</sub> above the start threshold before setting at 15V.