

## DC-DC CONVERTER

### FEATURES

- Miniature Package (SOT-23L)
- Low Start-up Voltage [0.6 V (typ.)]
- Few External Components
- Selectable Output Voltage (1.9 V or 2.8 V)
- High and Low Current Optimized Designs

### APPLICATIONS

- Pagers
- Cassette Recorders
- Cordless Telephones
- Portable Instrumentation
- Radio Control Systems
- Mobile Radios
- Battery Operated Equipment
- Local Area Network (LAN) Receivers

### DESCRIPTION

The TK11811 is a low power, low input voltage DC-DC converter.

This device can be optimized for use in high or low current applications through component selection. The output voltage is selectable for 1.9 or 2.8 V operation and can be trimmed to any voltage in between.

The frequency of the built-in relaxation oscillator is set by external components. The internal voltage regulator provides a stable output voltage. Optimized Toko inductor components are available.

The TK11811 is available in a miniature SOT-23L surface mount package.

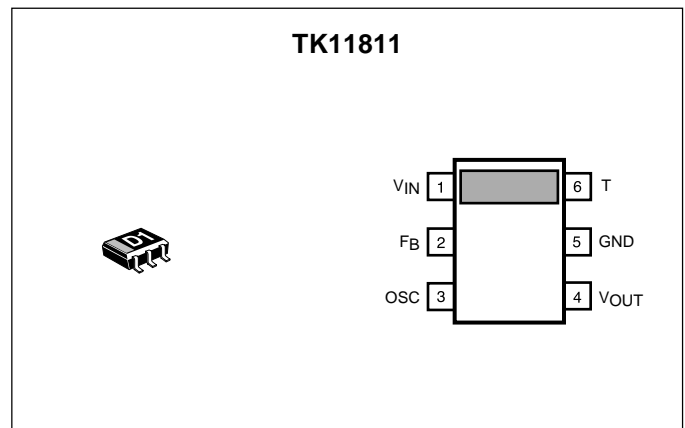

**ORDERING INFORMATION**

TK11811M Tape/Reel Code

TAPE/REEL CODE  
TL: Tape Left

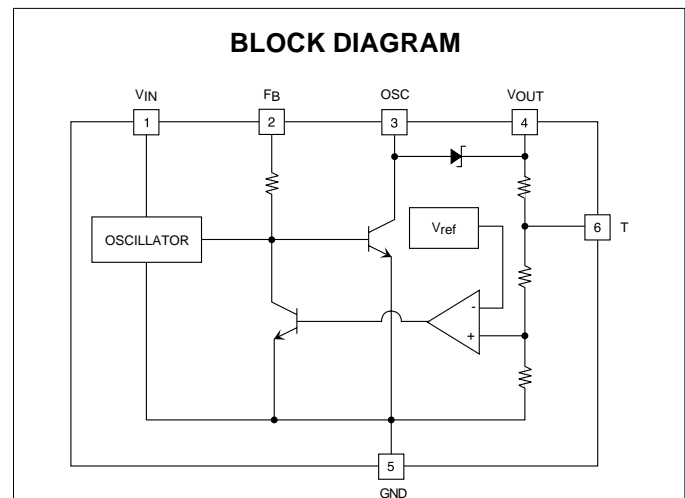

# TK11811

## ABSOLUTE MAXIMUM RATINGS

Input Voltage .....	16 V	Storage Temperature Range .....	-55 to +150 °C
Power Dissipation (Note 1) .....	200 mW	Operating Temperature Range .....	-10 to +65 °C
Junction Temperature .....	150 °C	Lead Soldering Temperature (10 s) .....	235 °C

## TK11811 ELECTRICAL CHARACTERISTICS

Test Conditions:  $T_A = 25\text{ °C}$ ,  $V_{OUT} = 2.9\text{ V}$  ( $V_{OUT}$  to T open), unless otherwise specified.

SYMBOL	PARAMETER	TEST CONDITIONS	MIN	TYP	MAX	UNITS
$V_{IN}$	Supply Voltage Range			0.6	14	V
$V_{START}$	Start-up Voltage	$I_{OUT} = 0\text{ mA}$		0.6	0.75	V
$I_{IN}$	Input Current	$V_{IN} = 1.1\text{ V}$ , $I_{OUT} = 3\text{ mA}$		11.0		mA
		$V_{IN} = 1.4\text{ V}$ , $I_{OUT} = 3\text{ mA}$		8.3		mA
$V_{OUT}$	Output Voltage	$V_{IN} = 1.1\text{ V}$ , $I_{OUT} = 3\text{ mA}$		2.85		V
		$V_{IN} = 1.4\text{ V}$ , $I_{OUT} = 3\text{ mA}$	2.70	2.85	3.0	V
$V_{OUT(LOW)}$	Output Voltage (LOW)	$V_{IN} = 1.1\text{ V}$ , $I_{OUT} = 3\text{ mA}$ , T to $V_{OUT}$ connected	1.75	1.90	2.05	V
$I_{OUT}$	Output Current	$V_{IN} = 1.1\text{ V}$	4.0	4.5		mA
		$V_{IN} = 1.4\text{ V}$	6.0	6.8		mA
Line Reg	Line Regulation	$I_{OUT} = 3\text{ mA}$ , $1.1\text{ V} \leq V_{IN} \leq 2.0\text{ V}$		10		mV
Load Reg	Load Regulation	$V_{IN} = 1.1\text{ V}$ , $0.5\text{ mA} \leq I_{OUT} \leq 3\text{ mA}$		45		mV
EFF	Efficiency	$V_{IN} = 1.4\text{ V}$ , $I_{OUT} = 3\text{ mA}$	63	72		%
$F_{OSC}$	Oscillator Frequency	$V_{IN} = 1.4\text{ V}$ , $I_{OUT} = 3\text{ mA}$ , (Note 2)		300		kHz
$\Delta V_{OUT}/\Delta T$	Temperature Coefficient	$V_{IN} = 1.4\text{ V}$ , $I_{OUT} = 3\text{ mA}$		0.7		mV/°C

Note 1: Power dissipation is 400 mW when mounted as recommended. Derate at 3.2 mW/°C for operation above 25 °C. Power dissipation is 200 mW when in Free Air. Derate at 1.6 mW/°C for operation above 25 °C.

Note 2: This IC is a frequency-controlled DC-DC converter; thus the value is varied by condition.

**TEST CIRCUIT**

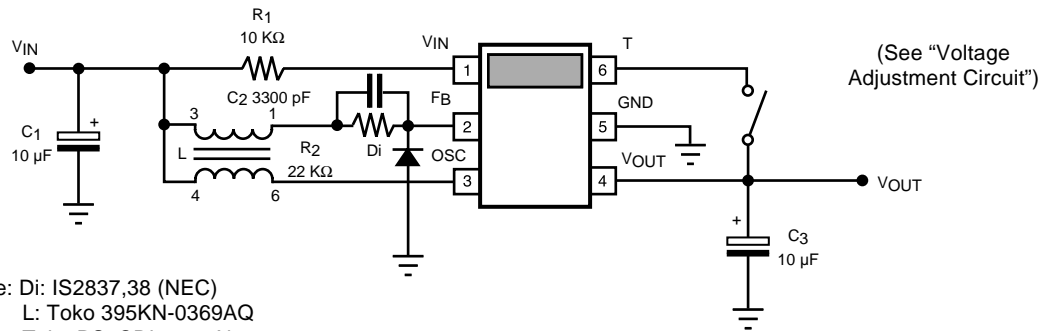

Note: Di: IS2837,38 (NEC)  
 L: Toko 395KN-0369AQ  
 Toko PS5CDL-1639X

**TYPICAL PERFORMANCE CHARACTERISTICS**

$T_A = 25^\circ\text{C}$ , unless otherwise specified.

**OUTPUT VOLTAGE vs. OUTPUT CURRENT ( $V_{OUT} = 1.9\text{ V}$ )**

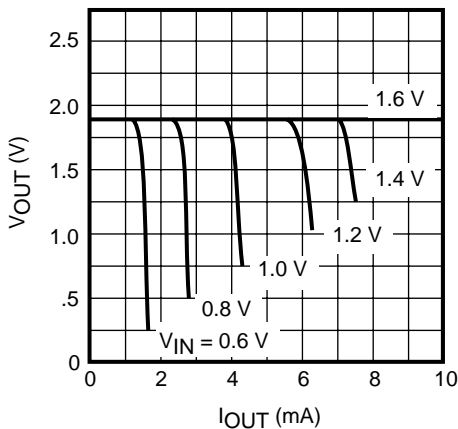

**EFFICIENCY vs. OUTPUT CURRENT ( $V_{OUT} = 1.9\text{ V}$ )**

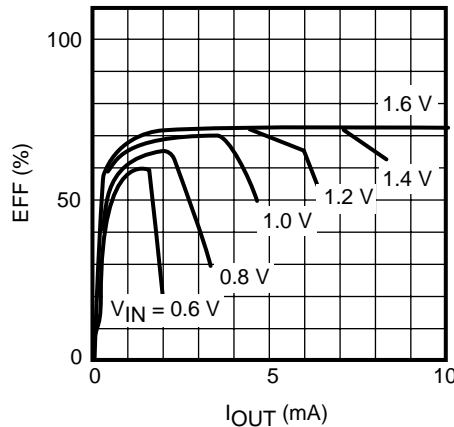

**OUTPUT VOLTAGE vs. OUTPUT CURRENT ( $V_{OUT} = 2.8\text{ V}$ ,  $I_{LOAD} = 0\text{ mA}$ )**

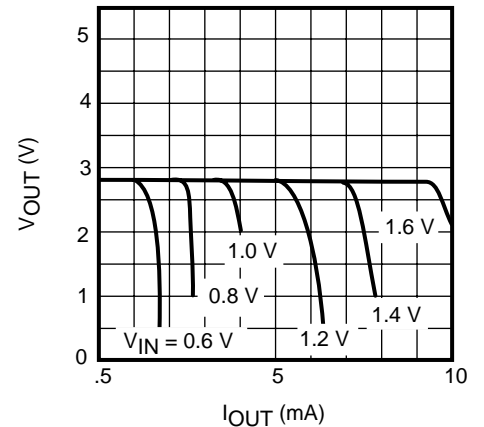

**EFFICIENCY vs. OUTPUT CURRENT ( $V_{OUT} = 2.8\text{ V}$ )**

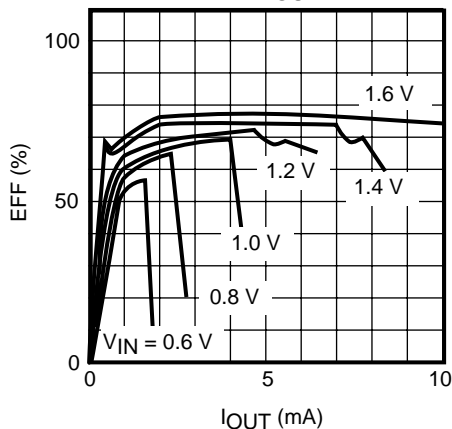

**INPUT CURRENT vs. INPUT VOLTAGE ( $I_{OUT} = 0\text{ mA}$ )**

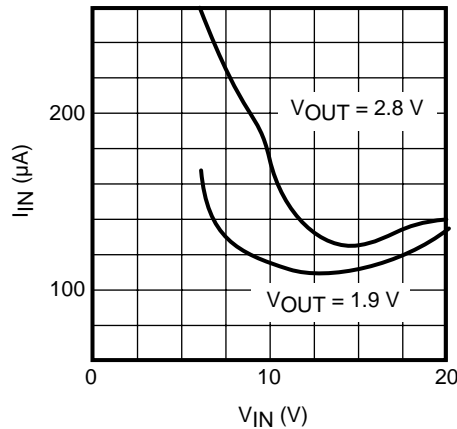

**OUTPUT VOLTAGE DRIFT vs. TEMPERATURE**

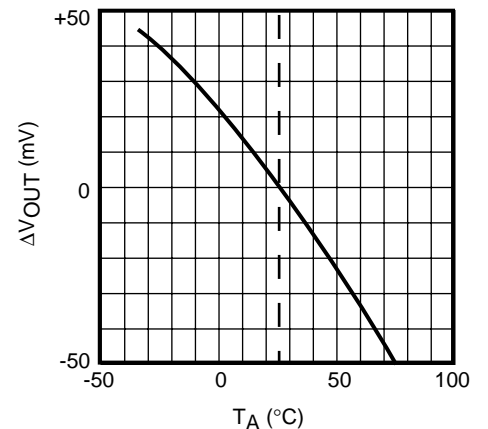

**TEST CIRCUIT**

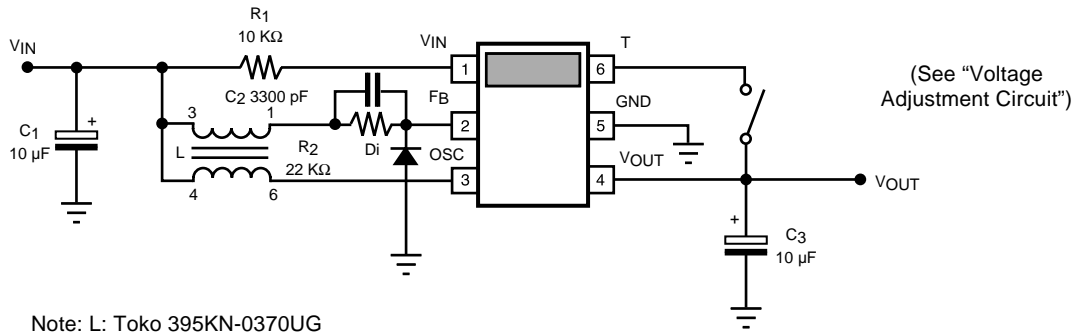

Note: L: Toko 395KN-0370UG

Note: This test circuit is effective at low load current.

**TYPICAL PERFORMANCE CHARACTERISTICS**

$T_A = 25^\circ\text{C}$ , unless otherwise specified.

**OUTPUT VOLTAGE vs. OUTPUT CURRENT**

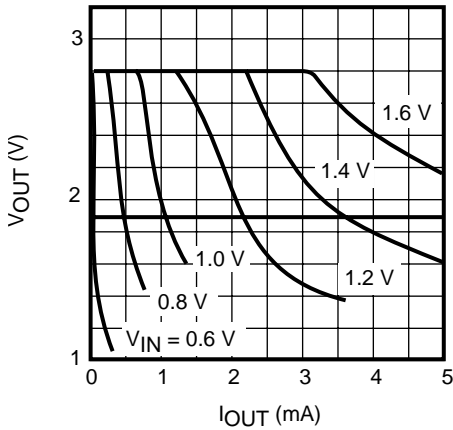

**EFFICIENCY vs. OUTPUT CURRENT**

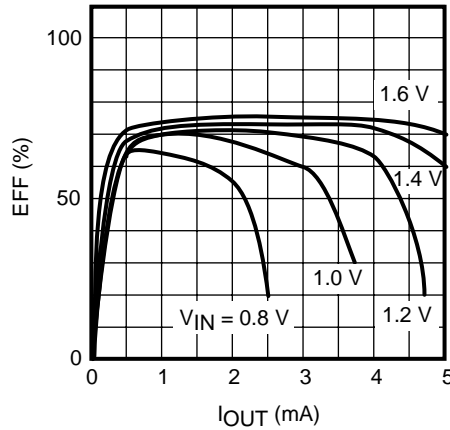

**INPUT CURRENT vs. INPUT VOLTAGE ( $I_{OUT} = 0 \text{ mA}$ )**

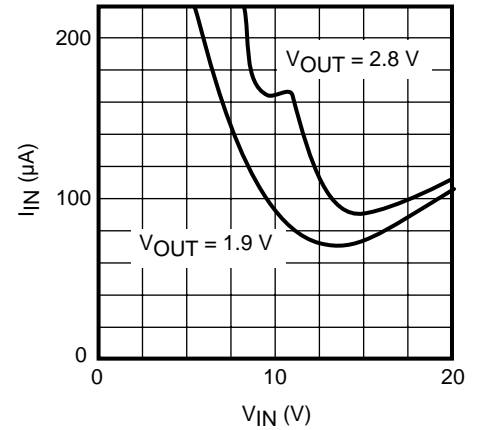

**TEST CIRCUIT**

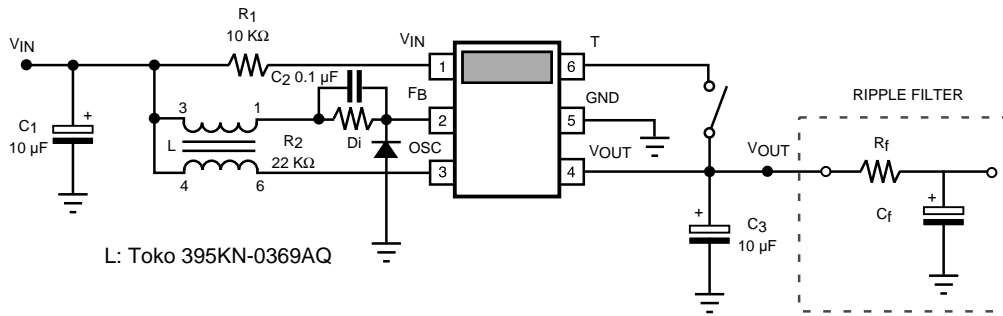

Note: This test circuit is effective at high load currents. By changing  $C_2$  from 3300pF to 0.1  $\mu$ F, the converter operates in the burst mode. The apparent frequency of operation drops (70 to 100 kHz) and a larger output ripple occurs during burst mode operation. A ripple filter consisting of  $C_f$  and  $R_f$  can be added to the output to reduce noise. The values of  $C_f$  and  $R_f$  should be determined experimentally based on the design parameters. The output voltage will drop slightly due to  $R_f$ .

**TYPICAL PERFORMANCE CHARACTERISTICS**

$T_A = 25^\circ\text{C}$ , unless otherwise specified.

**OUTPUT VOLTAGE vs. OUTPUT CURRENT**

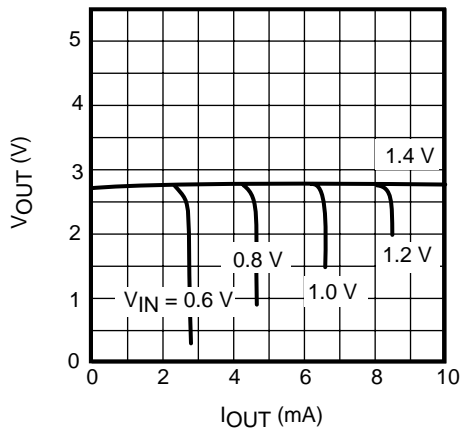

**EFFICIENCY vs. OUTPUT CURRENT**

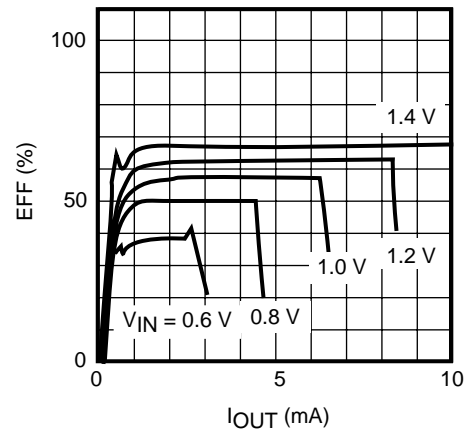

## VOLTAGE ADJUSTMENT CIRCUIT

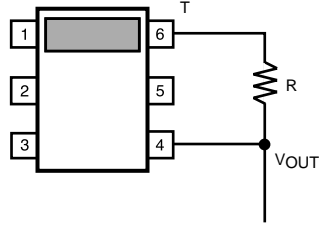

$V_{OUT}$	1.9	2.0	2.1	2.2	2.3	2.4	2.5	2.6	2.7	2.8
R	0	12 k	22 k	33 k	56 k	82 k	150 k	330 k	560 k	*

Note: The output voltage can be set between 1.9 V and 2.8 V with an external resistor connected between pins 4 and 6.

## ADDITIONAL INFORMATION

### APPLICATION INFORMATION

Maximize copper foil area connecting to all IC pins for optimum performance. Place input and output bypass capacitors close to the GND pin. For best transient behavior and lowest output impedance use as large a capacitor value as possible. The temperature coefficient of the capacitance and Equivalent Series Resistant (ESR) should be taken into account. These parameters can influence power supply noise and ripple rejection. In extreme cases, oscillation may occur. In order to maintain stability, the output bypass capacitor value should be minimum 10  $\mu\text{F}$  in case of tantalum electrolytic or 15  $\mu\text{F}$  in case of aluminum electrolytic.

### HANDLING MOLDED RESIN PACKAGES

All plastic molded packages absorb some moisture from the air. If moisture absorption occurs prior to soldering the device into the printed circuit board, increased separation of the lead from the plastic molding may occur, degrading the moisture barrier characteristics of the device. This property of plastic molding compounds should not be overlooked, particularly in the case of very small packages where the plastic is very thin. In order to preserve the original moisture barrier properties of the package, devices are stored and shipped in moisture proof bags filled with dry air. The bags should not be opened or damaged prior

to actual use of the devices. If this is unavoidable, the devices should be stored in a low relative humidity environment (40 to 65 %) or in an enclosed environment with desiccant.

### INDUCTOR NOTES

The output current and efficiency are largely dependant upon the coil used. A coil with lower DC resistance is generally better in efficiency than one with a higher DCR (DC Resistance). The recommended TOKO 395KN-0369 AQ is 1:1 turns ratio transformer with an inductance of 110  $\mu\text{H}$  and Toko 395KN-0370UG is 1:3 turns ratio transformer with inductance of 60  $\mu\text{H}$ :600  $\mu\text{H}$ . These coils, or equivalent, should be used. Smaller coils with higher DCR will not perform as well as the above coil, and the oscillator will not be stable.

### FEEDBACK RC TIME CONSTANT

If a different coil is used other than the one mentioned, the RC time constant of the feedback loop will need to be adjusted for optimum performance. Generally, a lower resistance will give more output current. In fact, R can be zero; however, lower resistance will sacrifice efficiency at low output currents as the quiescent current increases. If the capacitance is increased beyond or below a certain value, the oscillator will become unstable. The optimum

## ADDITIONAL INFORMATION (CONT.)

RC values depend upon the operating current, and should be chosen experimentally using the given values of 3300 pF and 22 k $\Omega$  as a starting point.

### INPUT/OUTPUT DECOUPLING CAPACITORS

DC-DC converters generate a large ripple current on both the input and the output of the circuit. The capacitors used should be as large as possible and have low impedance in the 300 kHz range. Since low temperatures cause capacitors to decrease capacitance and increase Equivalent Series Resistance (ESR), care should be taken to choose capacitors that have acceptable characteristics over the temperature range you intend to use. This should be done experimentally to verify results, as capacitor performance varies widely from manufacturer to manufacturer. Tantalum capacitors are generally the best choice and 10  $\mu$ F should be adequate for most applications.

### LOAD CHARACTERISTICS

The TK11811 should not be allowed to start-up under full load conditions. If this occurs, the output may not stabilize to the correct output voltage. This can be compensated for, somewhat, by adjusting the RC of the feedback loop or by decreasing the output decoupling capacitor. Maximum current can be drawn after the oscillator has started and the output has reached nominal output voltage. This is more critical with input voltages under 1.3 V as the converter needs to generate sufficient output to ensure correct internal bandgap and bias voltages.

PACKAGE OUTLINE

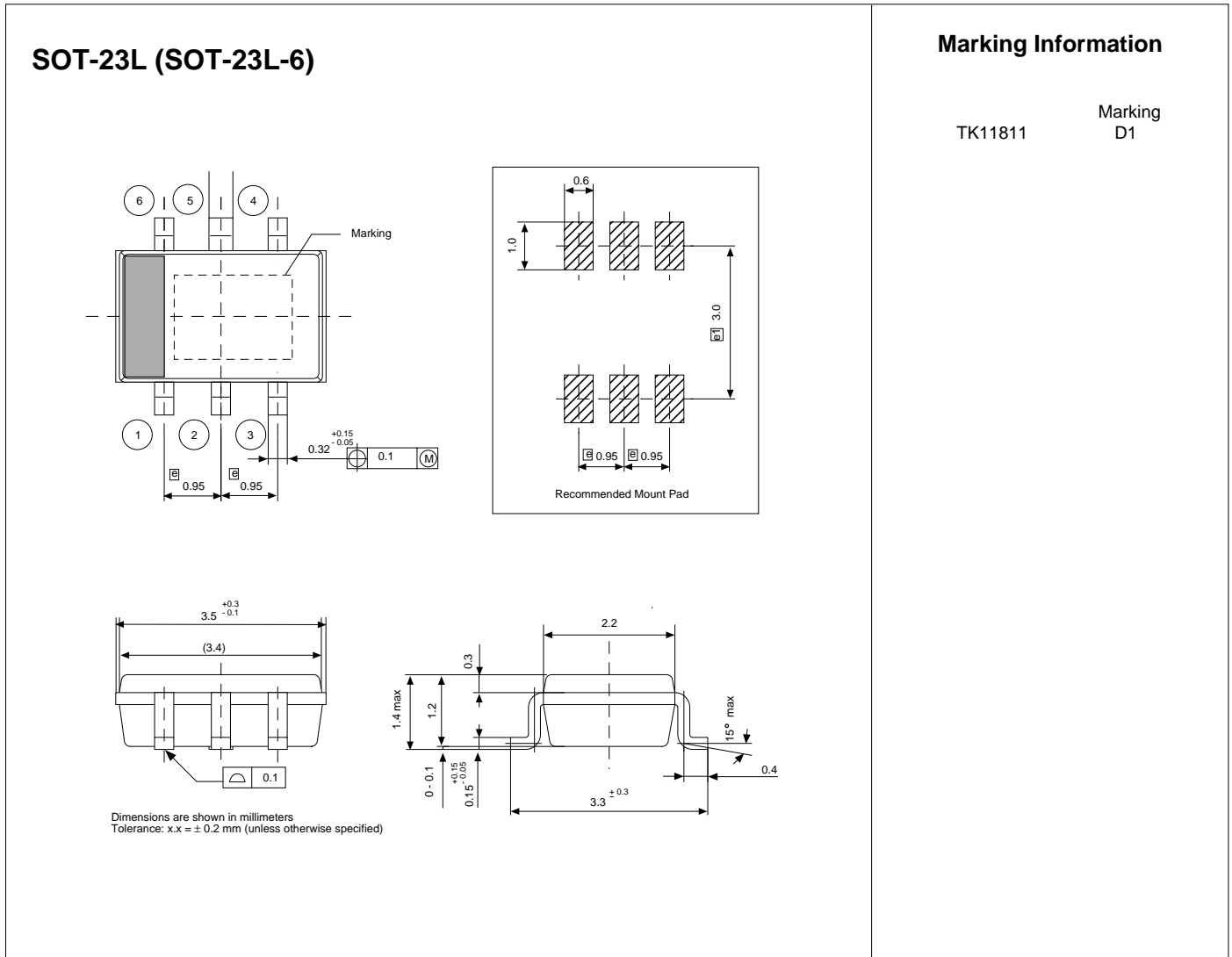

Toko America, Inc. Headquarters  
1250 Feehanville Drive, Mount Prospect, Illinois 60056  
Tel: (847) 297-0070 Fax: (847) 699-7864

TOKO AMERICA REGIONAL OFFICES

Midwest Regional Office  
Toko America, Inc.  
1250 Feehanville Drive  
Mount Prospect, IL 60056  
Tel: (847) 297-0070  
Fax: (847) 699-7864

Western Regional Office  
Toko America, Inc.  
2480 North First Street, Suite 260  
San Jose, CA 95131  
Tel: (408) 432-8281  
Fax: (408) 943-9790

Eastern Regional Office  
Toko America, Inc.  
107 Mill Plain Road  
Danbury, CT 06811  
Tel: (203) 748-6871  
Fax: (203) 797-1223

Semiconductor Technical Support  
Toko Design Center  
4755 Forge Road  
Colorado Springs, CO 80907  
Tel: (719) 528-2200  
Fax: (719) 528-2375

Visit our Internet site at <http://www.tokoam.com>

The information furnished by TOKO, Inc. is believed to be accurate and reliable. However, TOKO reserves the right to make changes or improvements in the design, specification or manufacture of its products without further notice. TOKO does not assume any liability arising from the application or use of any product or circuit described herein, nor for any infringements of patents or other rights of third parties which may result from the use of its products. No license is granted by implication or otherwise under any patent or patent rights of TOKO, Inc.