

# 100BASE-TX Physical Layer with MII

## GENERAL DESCRIPTION

The ML6692 implements the complete physical layer of the Fast Ethernet 100BASE-TX standard. The ML6692 interfaces to the controller through the standard-compliant Media Independent Interface (MII). The ML6692 functionality includes auto-negotiation, 4B/5B encoding/decoding, Stream Cipher scrambling/descrambling, 125MHz clock recovery/generation, receive adaptive equalization, baseline wander correction, and MLT-3/10BASE-T transmitter.

For applications requiring 100Mbps only, such as repeaters, the ML6692 offers a single-chip per-port solution. For 10/100 dual speed adapters or switches, 10BASE-T functionality may be attained using Micro Linear's ML2653, or by using an Ethernet controller that contains an integrated 10BASE-T PHY.

## FEATURES

- Single-chip 100BASE-TX physical layer
- Compliant to IEEE 802.3u 100BASE-TX standard
- Supports adapter, repeater and switch applications
- Single-jack 10BASE-T/100BASE-TX solution when used with external 10Mbps PHY
- Compliant MII (Media Independent Interface)
- Auto-negotiation capability
- 4B/5B encoder/decoder
- Stream Cipher scrambler/descrambler
- 125MHz clock recovery/generation
- Baseline wander correction
- Adaptive equalization and MLT-3 encoding/decoding
- Supports full-duplex operation

## BLOCK DIAGRAM (PLCC Package)

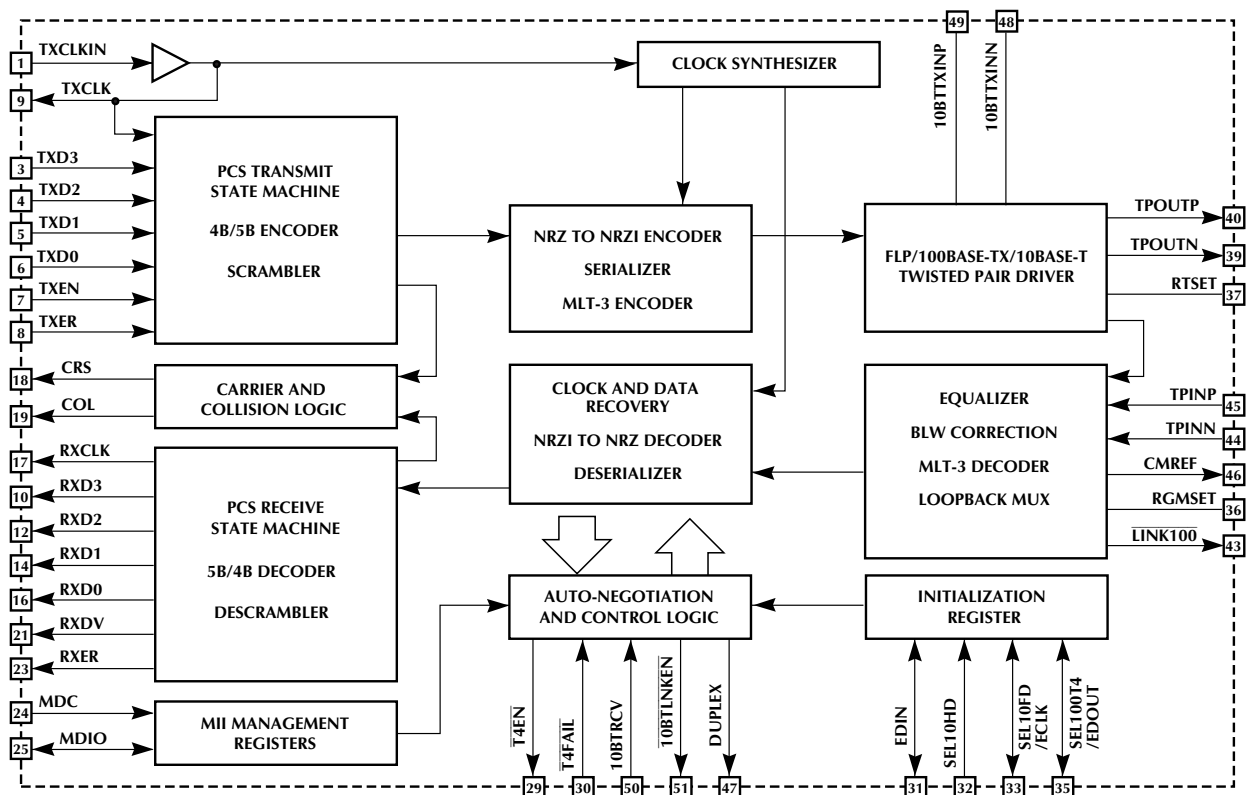

## PIN CONFIGURATION

### ML6692 52-Pin PLCC (Q52)

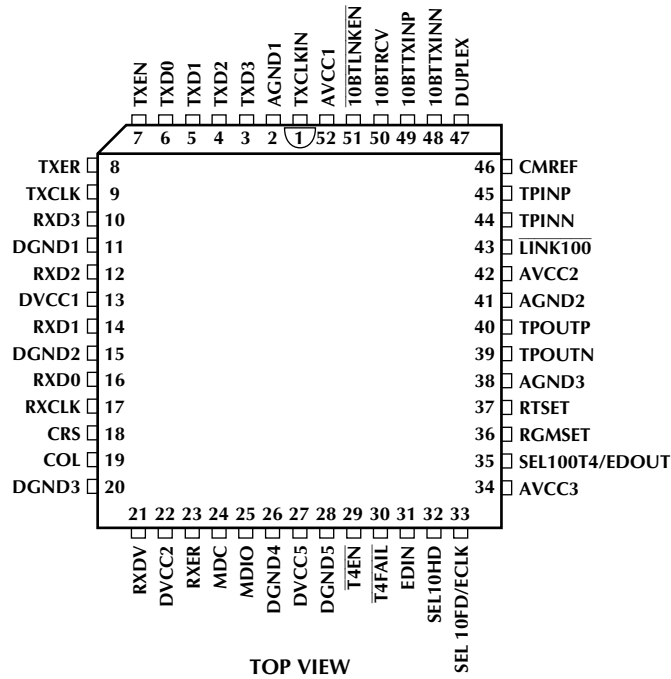

PIN CONFIGURATION

ML6692  
64-Pin TQFP (H64-10)

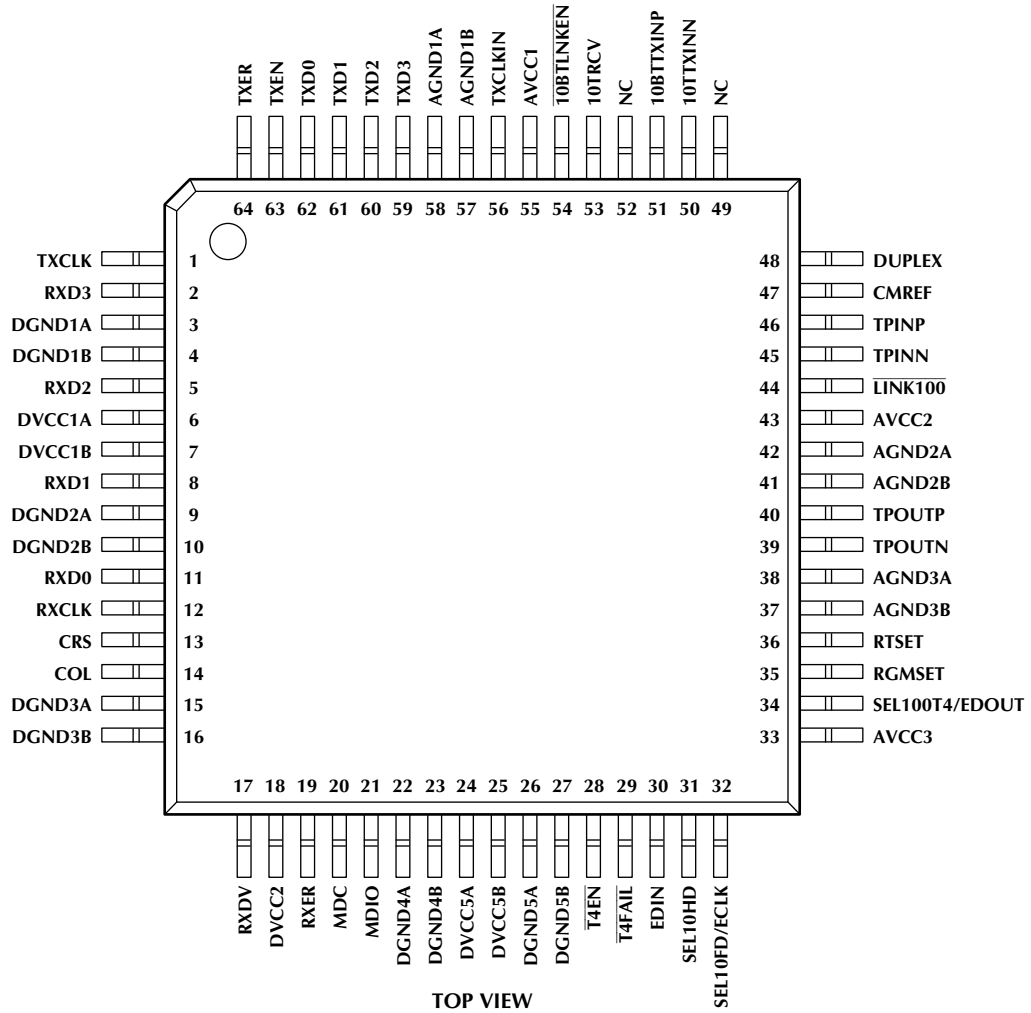

## PIN DESCRIPTION (Pin Numbers for TQFP package in parentheses)

PIN	NAME	FUNCTION
1 (56)	TXCLKIN	Transmit clock TTL input. This 25MHz clock is the frequency reference for the internal transmit PLL clock multiplier. This pin should be driven by an external 25MHz clock at TTL or CMOS levels.
2 (57, 58)	AGND1	Analog ground.
3, 4, 5, 6, (59, 60, 61, 62)	TXD<3:0>	Transmit data TTL inputs. TXD<3:0> inputs accept TX data from the MII. Data appearing at TXD<3:0> are clocked into the ML6692 on the rising edge of TXCLK.
7 (63)	TXEN	Transmit enable TTL input. Driving this input high indicates to the ML6692 that transmit data are present at TXD<3:0>. TXEN edges should be synchronous with TXCLK.
8 (64)	TXER	Transmit error TTL input. Driving this pin high with TXEN also high causes the part to continuously transmit scrambled H symbols. When TXEN is low, TXER has no effect.
9 (1)	TXCLK	Transmit clock TTL output. This 25MHz clock is phase-aligned with the internal 125MHz TX bit clock. Data appearing at TXD<3:0> are clocked into the ML6692 on the rising edge of this clock.
10, 12, 14, 16 (2, 5, 8, 11)	RXD<3:0>	Receive data TTL outputs. RXD<3:0> outputs are valid on RXCLK's rising edge.
11 (3, 4)	DGND1	Digital ground.
13 (6, 7)	DVCC1	Digital +5V power supply.
15 (9, 10)	DGND2	Digital ground.
17 (12)	RXCLK	Recovered receive clock TTL output. This 25MHz clock is phase-aligned with the internal 125MHz bit clock recovered from the signal received at TPINP/N. Receive data at RXD<3:0> changes on the falling edges and should be sampled on the rising edges of this clock. RXCLK is phase aligned to TXCLKIN when the 100BASE-TX signal is not present at TPINP/N.
18 (13)	CRS	Carrier Sense TTL output. For 100Mbps operation in standard mode, CRS goes high in the presenon-idle signals at TPINP/N, or when the ML6692 is transmitting. CRS goes low when there is no transmit activity and receive is idle. For 100 Mbps operation in repeater mode or half duplex mode, CRS goes high in the presence of non-idle signals at TPINP/N only.
19 (14)	COL	Collision Detected TTL output. For 100 Mbps operation COL goes high upon detection of a collision on the network, and remains high as long as the collision condition persists. COL is low when the ML6692 operates in either full duplex, or loopback modes.
20 (15, 16)	DGND3	Digital ground.
21 (17)	RXDV	Receive data valid TTL output. This output goes high when the ML6692 is receiving a data packet. RXDV should be sampled synchronously with RXCLK's rising edge.
22 (18)	DVCC2	Digital +5V power supply.
23 (19)	RXER	Receive error TTL output. This output goes high to indicate error or invalid symbols within a packet, or corrupted idle between packets. RXER should be sampled synchronously with RXCLK's rising edge.
24 (20)	MDC	MII Management Interface clock TTL input. A clock at this pin clocks serial data into or out of the ML6692's MII management registers through the MDIO pin. The maximum clock frequency at MDC is 2.5MHz.

**PIN DESCRIPTION** (Continued)

PIN	NAME	FUNCTION
25 (21)	MDIO	MII Management Interface data TTL input/output. Serial data are written to and read from the ML6692's management registers through this I/O pin. Input data is sampled on the rising edge of MDC. Data output should be sampled synchronously with MDC's rising edge.
26 (22, 23)	DGND4	Digital ground.
27 (24, 25)	DVCC5	Digital +5V power supply.
28 (26, 27)	DGND5	Digital ground.
29 (28)	$\overline{T4EN}$	100BASE-T4 enable TTL output. This output goes low if the auto-negotiation function chooses 100BASE-T4 as the highest common denominator technology. This output is high on power-up, during auto-negotiation, when the ML6692 enables any other protocol, or when 100BASE-T4 technology is not supported. If auto-negotiation is disabled, T4EN is always low.
30 (29)	$\overline{T4FAIL}$	100BASE-T4 link fail TTL input. When driven high, it indicates a good, 100BASE-T4 link. When the auto-negotiation function chooses 100BASE-T4 as the highest common denominator technology, and indicates it by driving T4EN low, T4FAIL should go high within 750-1000ms; otherwise auto-negotiation is restarted. Driving this pin low after auto-negotiation is completed, also restarts it. In the parallel detection function, driving this pin high indicates that the 100BASE-T4 link is ready. If auto-negotiation is disabled and management register bit 0.13 is set to 1 (100Mb/s data rate selected), driving T4FAIL high indicates a valid 100BASE-T4 link and disables the ML6692's 100BASE-TX analog functions. If bit 13 of the MII Control register is set to 0, T4FAIL has no effect.
31 (30)	EDIN	Initialization interface mode select and EEPROM interface mode data-in CMOS input/output. EDIN selects one of three possible interface modes at power up. See table on page 14 for more detail
32 (31)	SEL10HD	Initialization Interface 10BASE-T half duplex CMOS input. When EDIN is high or floating, this pin has no effect. When EDIN is low, this pin sets the value of bit 11 of the MII Status register (10Mb/s half duplex), and the default value of bit 5 of the MII Advertisement register (10BASE-T half duplex capability).
33 (32)	SEL10FD/ ECLK	Initialization Interface 10BASE-T full duplex CMOS input/clock CMOS input/output. ECLK When EDIN is low, this pin sets the value of bit 12 of the MII Status register (10Mb/s full duplex), and the default value of bit 6 of the MII Advertisement register (10BASE-T full duplex capability). When EDIN is left floating, this pin provides the output clock to read initialization data from an external EEPROM. When EDIN is high, this pin is the input clock to load data from an external microcontroller.
34 (33)	AVCC3	Analog +5V power supply.
35 (34)	SEL100T4/ EDOUT	Initialization Interface 100BASE-T4 CMOS input and EEPROM or microcontroller data-out CMOS input. When EDIN is low, this pin sets the value of bit 15 of the MII Status register (100BASE-T4), and the default value of bit 9 of the MII Advertisement register (100BASE-T4 capability). When EDIN is floating, this pin is the initialization data input from an external EEPROM. When EDIN is high, this pin is the initialization data input from a microcontroller.
36 (35)	RGMSSET	Equalizer bias resistor input. An external 9.53k $\Omega$ , 1% resistor connected between RGMSSET and AGND3 sets internal time constants controlling the receive equalizer transfer function.

## PIN DESCRIPTION (Continued)

37 (36)	RTSET	Transmit level bias resistor input. An external 2.49k $\Omega$ , 1% resistor connected between RTSET and AGND3 sets a precision constant bias current for the twisted pair transmit level.
38 (37, 38)	AGND3	Analog ground.
39, 40 (39, 40)	TPOUTN/P	Transmit twisted pair outputs. This differential current output pair drives FLP waveforms and MLT-3 waveforms into the network coupling transformer in 100BASE-TX mode, or 10BASE-T waveforms in 10BASE-T mode.
41 (41, 42)	AGND2	Analog ground.
42 (43)	AVCC2	Analog +5V power supply.
43 (44)	LINK100	100BASE-TX link activity open-drain output. LINK100 pulls low when there is 100BASE-TX activity at TPINP/N in 100BASE-TX or auto-negotiation modes. This output is capable of driving an LED directly.
44, 45 (45, 46)	TPINN/P	Receive twisted pair inputs. This differential input pair receives 100BASE-TX, FLP, or 10BASE-T signals from the network.
46 (47)	CMREF	Receiver common-mode reference output. This pin provides a common-mode bias point for the twisted-pair media line receiver, typically ( $V_{CC} - 1.26$ )V.
47 (48)	DUPLEX	Full duplex enabled TTL output. This output is high during the auto-negotiation process, it's low when auto-negotiation is reset (power-up, reset bit, restart auto-negotiation bit, power down bit, or link loss) and follows the duplex status otherwise. It drives the ML2653's FD input, and prevents the ML2653 from attempting to transmit during auto-negotiation. For 10BASE-T transceivers without pin-selectable MAU loopback disable, DUPLEX can be used to disable the 10BASE-T transceiver's receive and collision outputs to the controller during auto-negotiation.
48, 49 (50, 51)	10BTTXINN/P	10BASE-T transmit waveform inputs. The ML6692 presents a linear copy of the input at 10BTTXINP/N to the TPOUTP/N outputs when the ML6692 functions in 10BASE-T mode. Signals presented to these pins must be centered at $V_{CC}/2$ and have a single ended amplitude of $\pm 0.25$ V.
50 (53)	10BTRCV	10BASE-T receive activity TTL input. The external 10BASE-T transceiver drives this pin high to indicate 10BASE-T packet reception from the network.
51 (54)	10BTLNKEN	10BASE-T link control TTL output. This output is low if the ML6692 is in 10BASE-T mode, or if the auto-negotiation function indicates to the 10BASE-T PMA to scan for carrier. This output is high if the 10BASE-T PMA should be disabled.
52 (55)	AVCC1	Analog +5V power supply.

## ABSOLUTE MAXIMUM RATINGS

Absolute maximum ratings are those values beyond which the device could be permanently damaged. Absolute maximum ratings are stress ratings only and functional device operation is not implied.

V <sub>CC</sub> Supply Voltage Range	GND –0.3V to 6V
Input Voltage Range	
Digital Inputs	GND –0.3V to V <sub>CC</sub> +0.3V
TPINP, TPINN, 10BTTXNP, 10BTTXINN,	
	GND –0.3V to V <sub>CC</sub> +0.3V
Output Current	
TPOUTP, TPOUTN	60mA
All other outputs	10mA
Junction Temperature	150°C
Storage Temperature	–65°C to +150°C

Lead Temperature (Soldering, 10 sec)	260°C
Thermal Resistance ( $\theta_{JA}$ )	
PLCC	40°C/W
TQFP	52°C/W

## OPERATING CONDITIONS

V <sub>CC</sub> Supply Voltage	5V ±5%
All V <sub>CC</sub> supply pins must be within 0.1V of each other.	
All GND pins must be within 0.1V of each other.	
T <sub>A</sub> , Ambient temperature	0°C to 70°C
RGMSET	9.53kΩ ± 1%
RTSET	2.49kΩ ± 1%
Receive transformer insertion loss	<–0.5dB

## DC ELECTRICAL CHARACTERISTICS

Over full range of operating conditions unless otherwise specified (Note 1).

SYMBOL	PARAMETER	CONDITIONS	MIN	TYP	MAX	UNITS
<b>RECEIVER</b>						
V <sub>ICM</sub>	TPINP/N Input Common-Mode Voltage (CMREF)			V <sub>CC</sub> – 1.26		V
V <sub>ID</sub>	TPINP-TPINN Differential Input Voltage Range		–3.0		3.0	V
R <sub>IDR</sub>	TPINP-TPINN Differential Input Resistance		10.0k			Ω
I <sub>ICM</sub>	TPINP/N Common-Mode Input Current				+10	μA
I <sub>RGM</sub>	RGMSET Input Current	RGMSET = 9.53kΩ		130		μA
I <sub>RT</sub>	RTSET Input Current	RTSET = 2.49kΩ		500		μA
<b>LED OUTPUT (LINK100)</b>						
I <sub>OLS</sub>	Output Low Current				5	mA
I <sub>OHS</sub>	Output Off Current				10	μA
<b>TRANSMITTER</b>						
I <sub>TD100</sub>	TPOUTP/N 100BASE-TX Mode Differential Output Current	Note 2, 3	±19		±21	mA
I <sub>TD10</sub>	TPOUTP/N 10BASE-T Mode Differential Output Current		±55	±60	±65	mA
I <sub>TOFF</sub>	TPOUTP/N Off-State Output	R <sub>L</sub> = 200, 1%	0		1.5	mA
I <sub>TXI</sub>	TPOUTP/N Differential Output Current Imbalance	R <sub>L</sub> = 200, 1%			500	μA

## DC ELECTRICAL CHARACTERISTICS (Continued)

SYMBOL	PARAMETER	CONDITIONS	MIN	TYP	MAX	UNITS
<b>TRANSMITTER (Continued)</b>						
X <sub>ERR</sub>	TPOUTP/N Differential Output Current Error	V <sub>OUT</sub> = V <sub>CC</sub> ; Note 3	-5.0		+5.0	%
X <sub>CMP100</sub>	TPOUTP/N 100BASE-X Output Current Compliance Error	V <sub>OUT</sub> = V <sub>CC</sub> ± 2.2V; referred to I <sub>OUT</sub> at V <sub>CC</sub>	-2.0		+2.0	%
V <sub>OCM10</sub>	TPOUTP/N 10BASE-T Output Voltage Compliance Range	I <sub>TD10</sub> remains within specified values	V <sub>CC</sub> - 2.7		V <sub>CC</sub> + 2.7	V
V <sub>ICM10</sub>	10BTXNN/P Input Common-Mode Voltage Range		V <sub>CC</sub> /2 - 0.3		V <sub>CC</sub> /2 + 0.3	V
<b>POWER SUPPLY CURRENT</b>						
I <sub>CC100</sub>	Supply Current, 100BASE-TX Operation, Transmitting	Current into all V <sub>CC</sub> pins		200	300	mA
I <sub>CC10</sub>	Supply Current, 10BASE-T Operation, Transmitting	Current into all V <sub>CC</sub> pins		40	70	mA
I <sub>CCOFF</sub>	Supply Current Power Down Mode	Current into all V <sub>CC</sub> pins			20	mA
I <sub>CCAUTO</sub>	Supply Current During Auto-negotiation	Current into all V <sub>CC</sub> pins		240	300	mA
<b>TTL INPUTS (TXD&lt;3:0&gt;, TXCLKIN, MDC, MDIO, TXEN, TXER, 10BTRCV, T4FAIL)</b>						
V <sub>IL</sub>	Input Low Voltage	I <sub>IL</sub> = -400μA			0.8	V
V <sub>IH</sub>	Input High Voltage	I <sub>IH</sub> = 100μA	2.0			V
I <sub>IL</sub>	Input Low Current	V <sub>IN</sub> = 0.4V	-200			μA
I <sub>IH</sub>	Input High Current	V <sub>IN</sub> = 2.7V			100	μA
<b>MII TTL OUTPUTS (RXD&lt;3:0&gt;, RXCLK, RXDV, RXER, CRS, COL, MDIO, TXCLK)</b>						
V <sub>OLT</sub>	Output Low Voltage	I <sub>OL</sub> = 4mA			0.4	V
V <sub>OHT</sub>	Output High Voltage	I <sub>OH</sub> = -4mA	2.4			V
<b>NON-MII TTL OUTPUTS (DUPLEX, T4EN, 10BTLNKEN)</b>						
V <sub>OLT</sub>	Output Low Voltage	I <sub>OL</sub> = 1mA			0.4	V
V <sub>OHT</sub>	Output High Voltage	I <sub>OH</sub> = -0.1mA	2.4			V
<b>CMOS INPUTS (EDIN, SEL10HD, SEL10FD/ECLK, SEL100T4/EDOUT)</b>						
V <sub>ILC</sub>	Input Low Voltage				0.2 × V <sub>CC</sub>	V
V <sub>IHC</sub>	Input High Voltage			0.8 × V <sub>CC</sub>		V
<b>CMOS OUTPUTS (SEL10FD/ECLK)</b>						
V <sub>OLC</sub>	Output Low Voltage	I <sub>OL</sub> = 2mA			0.1 × V <sub>CC</sub>	V
V <sub>OHC</sub>	Output High Voltage	I <sub>OL</sub> = -2mA	0.9 × V <sub>CC</sub>			v



## AC ELECTRICAL CHARACTERISTICS

Over full range of operating conditions unless otherwise specified

SYMBOL	PARAMETER	CONDITIONS	MIN	TYP	MAX	UNITS
<b>RECEIVER</b>						
V <sub>ICM</sub>	TPINP/N Input Common-Mode Voltage (CMREF)			V <sub>CC</sub> – 1.26		V
<b>TRANSMITTER (NOTE 3)</b>						
t <sub>TR/F</sub>	TPOUTP-TPOUTN Differential Rise/Fall Time	Notes 5, 6; for any legal code sequence	3.0		5.0	ns
t <sub>TM</sub>	TPOUTP-TPOUTN Differential Rise/Fall Time Mismatch	Notes 5, 6; for any legal code sequence	–0.5		0.5	ns
t <sub>TDC</sub>	TPOUTP-TPOUTN Differential Output Duty Cycle Distortion	Notes 4, 6	–0.5		0.5	ns
t <sub>TJT</sub>	TPOUTP-TPOUTN Differential Output Peak-to-Peak Jitter	Note 6		300	1400	ps
X <sub>Ost</sub>	TPOUTP-TPOUTN Differential Output Voltage Overshoot	Notes 6, 7			5	%
t <sub>CLK</sub>	TXCLKIN – TXCLK Delay		6		11	ns
t <sub>TXP</sub>	Transmit Bit Delay	Note 8			10.5	bit times
<b>RECEIVER</b>						
t <sub>RXDC</sub>	Receive Bit Delay (CRS)	Note 9			15.5	bit times
t <sub>RXDR</sub>	Receive Bit Delay (RXDV)	Note 10			25.5	bit times
<b>MII (MEDIA-INDEPENDENT INTERFACE)</b>						
X <sub>BTOL</sub>	TX Output Clock Frequency Tolerance	25MHz frequency	–100		+100	ppm
t <sub>TPWH</sub>	TXCLKIN pulse width HIGH		14			ns
t <sub>TPWL</sub>	TXCLKIN pulse width LOW		14			ns
t <sub>RPWH</sub>	RXCLK pulse width HIGH		14			ns
t <sub>RPWL</sub>	RXCLK pulse width LOW		14			ns
t <sub>TPS</sub>	Setup time, TXD<3:0> Data Valid to TXCLK Rising Edge (1.4V point)		13			ns
t <sub>TPH</sub>	Hold Time, TXD<3:0> Data Valid After TXCLK Rising Edge (1.4V point)		0			ns
t <sub>RCS</sub>	Time that RXD<3:0> Data are Valid Before RXCLK Rising Edge (1.4V point)		10			ns
t <sub>RCH</sub>	Time that RXD<3:0> Data are Valid After RXCLK Rising Edge (1.4V point)		10			ns
t <sub>RPCR</sub>	RXCLK 10% – 90% Rise Time				6	ns
t <sub>RPCF</sub>	RXCLK 90%-10% Fall Time				6	ns

## AC ELECTRICAL CHARACTERISTICS

SYMBOL	PARAMETER	CONDITIONS	MIN	TYP	MAX	UNITS
<b>MDC-MDIO (MII MANAGEMENT INTERFACE)</b>						
t <sub>SPWS</sub>	Write Setup Time, MDIO Data Valid to MDC Rising Edge 1.4V Point		10			ns
t <sub>SPWH</sub>	Write Hold Time, MDIO Data Valid After MDC Rising Edge 1.4V Point		10			ns
t <sub>SPRS</sub>	Read Setup Time, MDIO Data Valid to MDC Rising Edge 1.4V Point		100			ns
t <sub>SPRH</sub>	Read Hold time, MDIO Data Valid After MDC Rising Edge 1.4V Point		0			ns
t <sub>CPER</sub>	Period of MDC		400			ns
t <sub>CPW</sub>	Pulsewidth of MDC	Positive or negative pulses	160			ns
<b>INITIALIZATION INTERFACE</b>						
t <sub>PW1</sub>	ECLK Positive Pulsewidth	EDIN floating (EEPROM Mode)	900			ns
t <sub>PW2</sub>	ECLK Negative Pulsewidth	EDIN floating (EEPROM Mode)	900			ns
t <sub>PER1</sub>	ECLK Period, EEPROM Mode	EDIN floating (EEPROM Mode)	1800			ns
t <sub>DV1</sub>	EDOUT Data Valid Time After ECLK Rising Edge	EDIN floating (EEPROM Mode)			900	ns
t <sub>PER2</sub>	ECLK period	EDIN high (Microcontroller Mode)	5000			ns
t <sub>PW3</sub>	ECLK Positive Pulsewidth	EDIN high (Microcontroller Mode)	2000			ns
t <sub>PW4</sub>	ECLK Negative Pulsewidth	EDIN high (Microcontroller Mode)	2000			ns
t <sub>S1</sub>	ECLK Data Setup Time	EDIN high (Microcontroller Mode)	10			ns
t <sub>H1</sub>	ECLK Data Hold Time	EDIN high (Microcontroller Mode)	10			ns

**Note 1.** Limits are guaranteed by 100% testing, sampling, or correlation with worst case test conditions.

**Note 2.** Measured using the test circuit shown in fig. 1, under the following conditions:

$$R_{LP} = 200\Omega, R_{LS} = 49.9\Omega, R_{TSET} = 2.49k\Omega.$$

All resistors are 1% tolerance.

**Note 3.** Output current amplitude is  $I_{OUT} = 40\Omega \cdot 1.25V/RTSET$ .

**Note 4.** Measured relative to ideal negative and positive signal 50% points, using the four successive MLT-3 transitions for the 01010101 bit sequence.

**Note 5.** Time difference between 10% and 90% levels of the transition from the baseline voltage (nominally zero) to either the positive or negative peak signal voltage. The times specified here correlate to the transition times defined in the ANSI X3T9.5 TP-PMD Rev 2.0 working draft, section 9.1.6, which include the effects of the external network coupling transformer and EMI/RFI emissions filter.

**Note 6.** Differential test load is shown in fig. 1 (see note 2).

**Note 7.** Defined as the percentage excursion of the differential signal transition beyond its final adjusted value during the symbol interval following the transition. The adjusted value is obtained by doing a straight line best-fit to an output waveform containing 14 bit-times of no transition preceded by a transition from zero to either a positive or negative signal peak; the adjusted value is the point at which the straight line fit meets the rising or falling signal edge.

**Note 8.** From first rising edge of TXCLK after TXEN goes high, to first bit of J at the MDI.

**Note 9.** From first bit of J at the MDI, to CRS.

**Note 10.** From first bit of J at the MDI, to first rising edge of RXCLK after RXDV goes high.

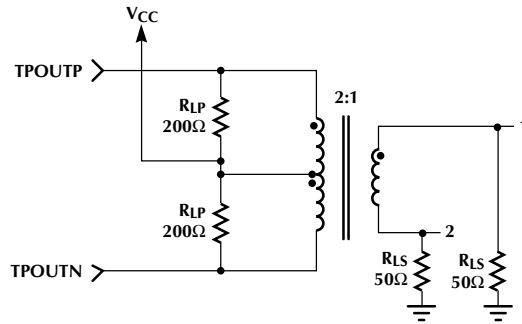

Figure 1.

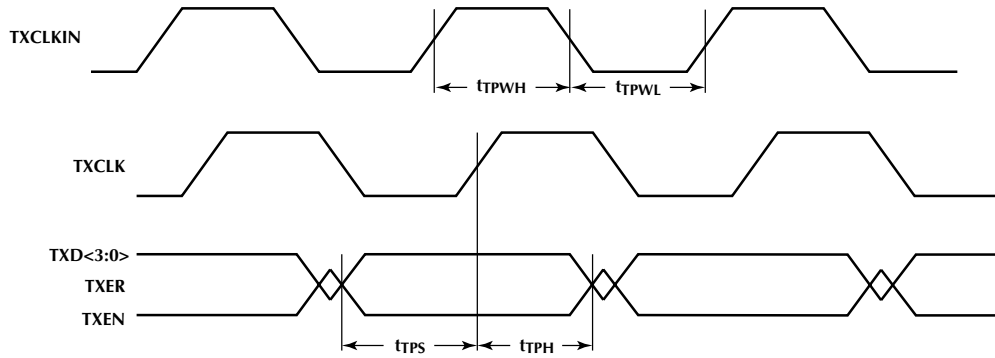

Figure 2. MII Transmit Timing

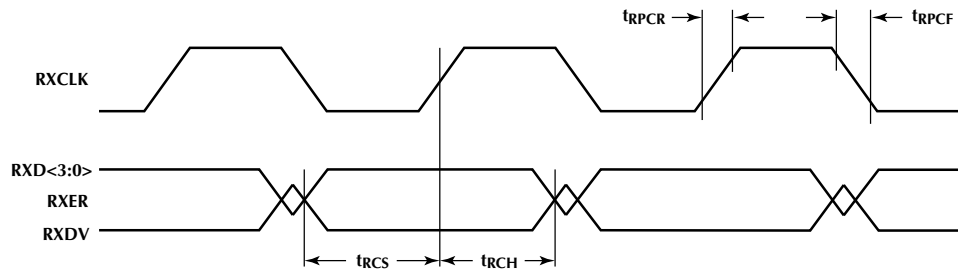

Figure 3. MII Receive Timing

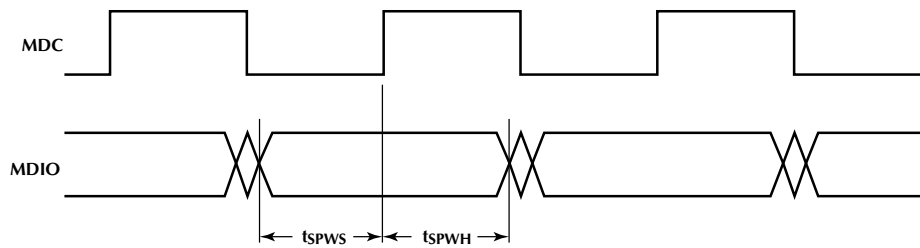

Figure 4. MII Management Interface Write Timing

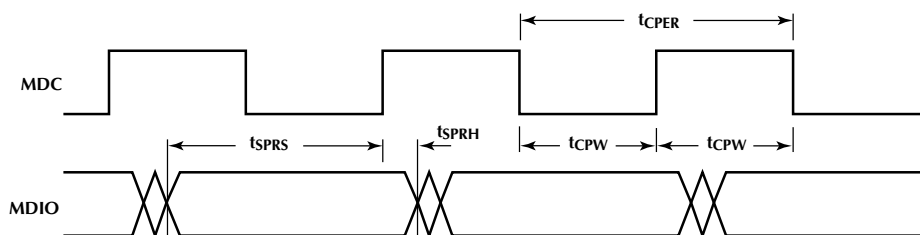

Figure 5. MII Management Interface Read Timing

## FUNCTIONAL DESCRIPTION

### TRANSMIT SECTION

#### 100BASE-TX Operation

The transmitter includes everything necessary to accept 4-bit data nibbles clocked in at 25MHz at the MII and output scrambled, 5-bit encoded MLT-3 signals into twisted pair at 100Mbps. The on-chip transmit PLL converts a 25MHz TTL-level clock at TXCLKIN to an internal 125MHz bit clock. TXCLK from the ML6692 clocks transmit data from the MAC into the ML6692's TXD<3:0> input pins upon assertion of TXEN. Data from the TXD<3:0> inputs are 5-bit encoded, scrambled, and converted from parallel to serial form at the 125MHz clock rate. The serial transmit data is converted to MLT-3 3-level code and driven differentially out of the TPOUTP and TPOUTN pins at nominal  $\pm 2V$  levels with the proper loads. The transmitter is designed to drive a center-tapped transformer with a 2:1 winding ratio, so a differential 400 $\Omega$  load is used on the transformer primary to properly terminate the 100 $\Omega$  cable and termination on the secondary. The transformer's center tap must be tied to  $V_{CC}$ . A 2:1 transformer allows using a  $\pm 20mA$  output current in 100BASE-TX mode and  $\pm 60mA$  in fast link pulse and 10BASE-T modes. Using a 1:1 transformer would have required twice the output current and increased the on-chip power dissipation. An external 2.49k $\Omega$ , 1% resistor at the RTSET pin creates the correct output levels at TPOUTP/N.

Driving TXER high when TXEN is high causes the H symbol (00100) to appear in scrambled MLT-3 form at TPOUTP/N. The media access controller asserts TXER synchronously with TXCLK rising edge, and the H symbol appears at least once in place of a valid symbol in the current packet.

With no data at TXD<3:0> or with the ML6692 in isolate mode (MII Management register bit 0.10 set to a 1), scrambled idle appears at TPOUTP/N.

#### Auto Negotiation and Fast Link Pulses (FLPs)

During the auto negotiation process, the transmitter produces nominal 5V fast link pulses (FLP's) at TPOUTP/N (2.5V after 2:1 transformer). When the auto negotiation process is complete, the transmitter either switches over to 100BASE-TX mode, activates the 10BTTXINP/N inputs for 10BASE-T operation with an external 10BASE-T transceiver, or enables a 100BASE-T4 PMA and powers down the on-chip transmitter.

#### 10BASE-T

In 10BASE-T mode, the transmitter acts as a linear buffer with a gain of 10. 10BASE-T inputs (Manchester data and normal link pulses) at 10BTTXINP/N appear as full-swing signals at TPOUTP/N in this mode. Inputs to the 10BTTXINP/N pins should have a nominal  $\pm 0.25V$  differential amplitude and a common-mode voltage of  $V_{CC}/2$ , and should also be waveshaped or filtered to meet

the 10BASE-T harmonic content requirements. The ML6692 does not provide any 10BASE-T transmit filtering. The ML2653 10BASE-T physical interface chip provides a waveshaped 10BASE-T output and may be used with a resistive load network for a simple 2-chip 10/100 solution with the ML6692. The ML2653 interfaces to a controller through its "7-wire" interface.

### RECEIVE SECTION

#### 100BASE-TX Operation

The receiver includes all necessary functions for converting 3-level MLT-3 signals from the twisted-pair media to 4-bit data nibbles at RXD<3:0> with extracted clock at RXCLK. The adaptive equalizer compensates for cable distortion and attenuation, corrects for DC baseline wander, and converts the MLT-3 signal to 2-level NRZ. The receive PLL extracts clock from the equalized signal, providing additional jitter attenuation, and clocks the signal through the serial to parallel converter. The resulting 5-bit nibbles are descrambled, aligned and decoded, and appear at RXD<3:0>. The ML6692 asserts RXDV when it's ready to present properly decoded receive data at RXD<3:0>. The extracted clock appears at RXCLK. Resistor RGMSET sets internal time constants controlling the adaptive equalizer's transfer function. RGMSET must be set to 9.53k $\Omega$  (1%).

The receiver will assert RXER high if it detects code errors in the receive data packet, or if the idle symbols between packets are corrupted.

COL goes high to indicate simultaneous 100BASE-TX receive and transmit activity (a collision). CRS goes high whenever there is either receive or transmit activity in the ML6692's "station" mode (the default mode; see Initialization Interface section below for more information). In the ML6692's "repeater" mode, CRS goes high only when there is receive activity.

#### Auto Negotiation

The 100BASE-TX signal detect circuit in the adaptive equalizer ignores fast and normal link pulses, and will not pass them on to the rest of the receive channel. Instead, FLPs (and NLPs) are recognized and processed by the auto negotiation logic. When the auto negotiation process is complete, either the adaptive EQ and the rest of the 100BASE-TX receive path remain active for 100BASE-TX reception, all the ML6692's receive circuitry is disabled and the external 10BASE-T transceiver is enabled (if it exists), or all the ML6692's 10BASE-T and 100BASE-TX functionality is disabled and an external 100BASE-T4 PMA is enabled. In 10BASE-T or 100BASE-T4 modes, the ML6692 RXD<3:0>, RXC, RXER, RXDV, COL and CRS MII outputs are in high impedance state. See the next section for more information on auto negotiation.

Proper connection of the TPIN pins, magnetics, and cable is necessary for proper auto negotiation since the ML6692

## FUNCTIONAL DESCRIPTION (Continued)

does not detect or correct errors in the polarity of fast or normal link pulses.

### USING THE ML6692 WITH AUTOMATIC LINK CONFIGURATION

The ML6692 supports automated link protocol negotiation and configuration. In the ML6692, the auto negotiation state machine checks the receive signal and detects the presence of link pulses in bursts or singly. The auto negotiation state machine then updates the status register in the management logic, and forces the receiver and transmitter to perform the appropriate function, depending on the remote link partner and local port capabilities.

If FLP (fast link pulse) bursts are detected, the auto negotiation state machine disables all protocol-specific link detection and drives the transmitter with answering FLP bursts. The auto negotiation state machine then enables the highest common denominator protocol between the local port and the remote link partner.

If the highest common denominator technology is 100BASE-TX, the ML6692 100BASE-TX receiver is enabled. If the highest common denominator technology is 10BASE-T, the auto negotiation state machine disables the ML6692 100BASE-TX receiver and enables 10BASE-T output from the ML6692's transmitter. If the highest common denominator technology is 100BASE-T4, the ML6692's transmitter and receiver are disabled and the external 100BASE-T4 transceiver is enabled.

The ML6692 supports the parallel detection function by checking simultaneously for normal or fast link pulses, 100BASE-TX signal activity at TPINP/N, or indication of 100BASE-T4 activity from the external 100BASE-T4 transceiver. If one of the locally supported protocols is detected, that protocol is enabled and all others are disabled. If the local port lacks 10BASE-T capability and NLPs are detected, the local auto negotiation state machine disables transmission of all link pulses to force the far-end station into link fail, and restarts auto-negotiation.

The ML6692 takes a number of specific actions depending on which supported technology is selected. If the 100BASE-TX technology is selected, the ML6692 switches its clock recovery circuit from tracking the local 125MHz bit clock to tracking the equalized, decoded receive signal, descrambles, decodes and finds the packet boundaries of the signal, asserts RXDV, and presents the decoded receive data nibbles at RXD<3:0>. The ML6692 will also drive 10BTLNKEN and T4EN high to deactivate external 10BASE-T and 100BASE-T4 transceivers. If the 100BASE-T4 transceiver detects activity, it will drive the ML6692's T4FAIL pin high and the ML6692 will place its receiver and transmitter in an idle state, and will drive 10BTLNKEN high.

With MII Management register bit 0.12 = 0 (auto negotiation disabled) the ML6692 can be forced into a certain mode using bits 0.13 (speed select), bit 0.8 (duplex mode), and pin T4FAIL, as shown in the following table.

SPEED SELECT	DUPLEX MODE	T4FAIL	MODE
1	1	0	100BASE-TX Full Duplex
1	0	0	100BASE-TX Half Duplex
1	X	1	100BASE-T4
0	1	X	10BASE-T Full Duplex
0	0	X	10BASE-T Half Duplex

### ML6692 PHY MANAGEMENT FUNCTIONS

The ML6692 has management functions controlled by the register locations given in Tables 2–6. There are five 16-bit MII Management registers, with several unused locations. Unused locations are generally reserved for future use. Register 0 (Table 2) is the basic control register (read/write). Register 1 (Table 3) is the basic status register (read-only). Register 4 (Table 4) is the auto-negotiation capability advertisement register. Register 5 (Table 5) is the auto-negotiation link partner ability register (what the far-end station is capable of; read-only). Register 6 (Table 6) is the auto-negotiation expansion register (indicates some additional auto-negotiation status information; read-only). Note that status bits 1.11-1.12 (10BASE-T capability) and 1.15 (100BASE-T4) depend on the values programmed through the Initialization Interface. See the initialization interface section for programming information. The ML6692 powers on with all management register bits set to their default values.

The ML6692's auto negotiation status and control register addresses and functions match those described for the MII in IEEE 802.3u section 22. IEEE 802.3u specifies the management data frame structure in section 22.2.4.4.

See the IEEE 802.3u Specification section 28 for auto negotiation state machine definition, FLP timing, and overall operation.

See IEEE 802.3u section 22.2.4 for a discussion of MII management functions and status/control register definitions.

## INITIALIZATION INTERFACE

The ML6692 has an Initialization Interface to allow register programming that is not supported by the MII Management Interface. The initialization data is loaded at power-up and cannot be changed afterwards. The pin EDIN selects one of three possible programming modes. The Initialization Register bit assignment is shown in Table 1.

### EEPROM PROGRAMMING

With EDIN floating (set to a high impedance), the ML6692 reads the 16 configuration bits from an external serial EEPROM (93LC46 or similar) using the industry-standard 3-wire serial I/O protocol. After power up, the ML6692 automatically generates the address at EDIN and the clock at ECLK to read out the 16 configuration bits. The EEPROM generates the configuration bit stream at EDOUT, synchronized with ECLK. Interface timing is shown in Figure 6. It is important to note that the ML6692 expects LSBs first, whereas the 93LC46 shifts MSBs out

first. Therefore, the data pattern must be reversed before programming it into the EEPROM.

### MICROCONTROLLER PROGRAMMING

With EDIN high, the ML6692 expects the 16 configuration bits transferred directly at EDOUT, synchronized with the first 16 clock rising edges provided externally at ECLK after power-up. This mode is useful with a small microcontroller; one controller can program several ML6692 parts by selectively toggling their ECLK pins. Interface timing is shown in Figure 7.

### ML6692 HARD-WIRED DEFAULT

With EDIN low, the SEL10HD, SEL10FD, and SEL100T4 pins set their corresponding bits in the management status register, and the ML6692 responds to MII PHYAD 00000 only.

EDIN	MODE	FUNCTION OF RELATED PINS		
		SEL10FD/ECLK	SEL100T4/EDOUT	SEL10HD
Floating (EEPROM ADDR)	EEPROM	ECLK (Output Clock to EEPROM)	EDOUT (Input Data from EEPROM)	No Affect
High	Microcontroller	ECLK (Input Clock from Microcontroller)	EDOUT (Input Data from Microcontroller)	No Affect
Low	Hardwired	SEL10FD (Initialization bit 9)	SEL100T4 (Initialization bit 8)	SEL10HD (Initialization bit 10)

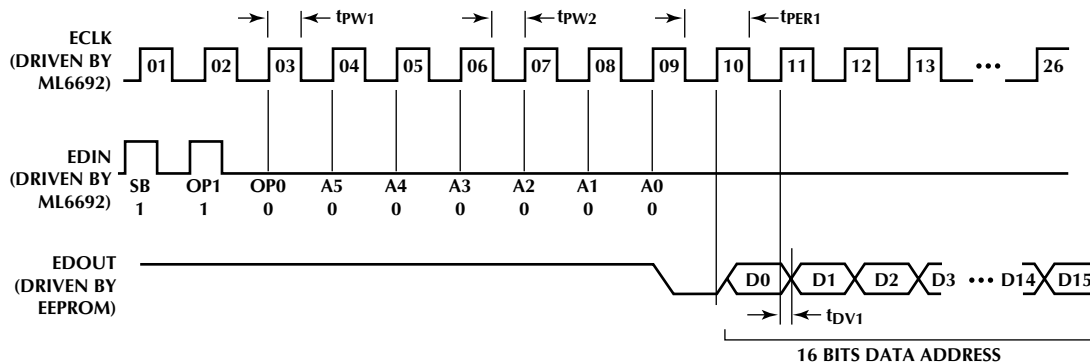

Figure 6. EEPROM Interface Timing

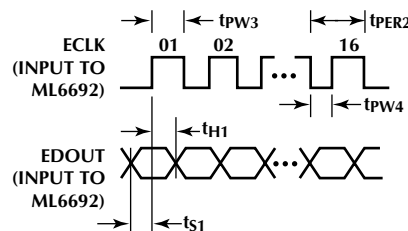

Figure 7. Microcontroller Mode Interface Timing

## INITIALIZATION INTERFACE REGISTER

BIT(S)	NAME	DESCRIPTION	R/W	DEFAULT
I.15	PHY A4	PHY address bit 4		0
I.14	PHY A3	PHY address bit 3		0
I.13	PHY A2	PHY address bit 2		0
I.12	PHY A1	PHY address bit 1		0
I.11	PHY A0	PHY address bit 0		0
I.10	10HDUP	10BASE-T half duplex initialization bit 1 = 10BASE-T (half-duplex) capability 0 = no 10BASE-T (half-duplex) capability		0
I.9	10FDUP	10BASE-T full duplex initialization bit 1 = 10Mb/s full duplex capability 0 = no 10Mb/s full duplex capability		0
I.8	100T4	100BASE-T4 initialization bit 1 = 100BASE-T4 capability 0 = no 100BASE-T4 capability		0
I.7	ISODIS	Isolate bit disable (bit 0.10)		0
I.6	REPEATER	Repeater mode: when this bit is set to 1, CRS is only asserted when receiving non-idle signal at TPINP/N, and the ML6692 is forced to half duplex mode		0
I.5–I.0	Not used			

Note: Bits I<10:8> are the values for bits 1.11, 1.12 and 1.15 and initial values for bits 4.5, 4.6 and 4.9 of the MII Management Interface.

**Table 1. Initialization Interface Register**

## MII MANAGEMENT INTERFACE REGISTERS

BIT(S)	NAME	DESCRIPTION	R/W	DEFAULT
0.15	Reset	1 = reset all register bits to defaults 0 = normal operation	R/W, SC	0
0.14	Loopback	1 = PMD loopback mode 0 = normal operation	R/W	0
0.13	Manual speed select (Active when 0.12 = 0)	1 = 100Mb/s 0 = 10Mb/s	R/W	1
0.12	Auto negotiation enable	1 = enable auto negotiation 0 = disable auto negotiation	R/W	1
0.11	Power down	1 = power down 0 = normal operation	R/W	0
0.10	Isolate	1 = electrically isolate the ML6692 from MII 0 = normal operation	R/W	1
0.9	Restart auto negotiation	1 = restart auto negotiation 0 = normal operation	R/W, SC	0
0.8	Duplex mode	1 = Full duplex select, auto negotiation disabled 0 = Half duplex select, auto negotiation disabled	R/W	0
0.7	Collision Test	1 = enable COL signal test 0 = normal operation	R/W	0
0.6 – 0.0	Not Used			

**Table 2. Control Register**

## MII MANAGEMENT INTERFACE REGISTERS (Continued)

BIT(S)	NAME	DESCRIPTION	R/W	DEFAULT
1.15	100BASE-T4	1 = 100BASE-T4 capability 0 = no 100BASE-T4 capability	RO	100T4 (bit 1.8)
1.14	100BASE-TX full duplex	1 = full duplex 100BASE-TX capability 0 = No full duplex 100BASE-TX capability	RO	1
1.13	100BASE-TX half duplex	1 = half duplex 100BASE-TX capability 0 = no half duplex 100BASE-TX capability	RO	1
1.12	10Mb/s full duplex	1 = full duplex 10Mb/s capability 0 = No full duplex 10Mb/s capability	RO	10FDUP (Bit 1.9)
1.11	10BASE-T (half duplex)	1 = 10BASE-T (half duplex) capability 0 = No 10BASE-T (half duplex) capability	RO	10HDUP (Bit 1.10)
1.10 – 1.6	Not Used			
1.5	Auto negotiation compl.	1 = auto negotiation process complete 0 = auto negotiation not complete	RO	0
1.4	Not Used			
1.3	Auto negotiation ability	1 = auto negotiation capability available 0 = auto negotiation capability not available	RO	1
1.2	Link status	1 = one and only one PHY-specific link is up 0 = link is down	RO/LL	latch low after link fail until read
1.1	Not Used			
1.0	Extended capability	1 = extended register capabilities 0 = basic register set only	RO	1

Table 3. Status Register

BIT(S)	NAME	DESCRIPTION	R/W	DEFAULT
4.15	Next Page	1 = additional link code word pages 0 = no additional pages	RO	0
4.14	Reserved	Write as zero, ignore on read	RO	
4.13	Remote fault	1 = remote wire fault detected 0 = no remote wire fault detected	R/W	0
4.12-4.10	Reserved	<i>(Not used at present)</i>		
4.9	100BASE-T4 capability	1 = 100BASE-T4 capability 0 = no 100BASE-T4 capability	R/W	100T4 (Bit 1.8)
4.8	100BASE-TX full duplex	1 = 100BASE-TX full duplex capability 0 = no 100BASE-Tfull duplex	R/W	1
4.7	100BASE-TX	1 = 100BASE-TX capability 0 = no 100BASE-TX capability	R/W	1
4.6	10BASE-T full duplex	1 = 10BASE-T full duplex capability 0 = no 10BASE-T full duplex capability	R/W	10FDUP (Bit 1.9)
4.5	10BASE-T	1 = 10BASE-T capability 0 = no 10BASE-T capability	R/W	10HDUP (Bit 1.10)
4.4-4.1	Selector field	All these bits are 0 for 802.3 LANs	RO	0
4.0	Selector field	This bit is a 1 for 802.3 LANs	RO	1

Table 4. Advertisement Register



## MII MANAGEMENT INTERFACE REGISTERS (Continued)

BIT(S)	NAME	DESCRIPTION	R/W	DEFAULT
5.15	Next Page	1 = additional link code word pages 0 = no additional pages	RO	X
5.14	Acknowledge	1 = link partner's successful receipt of local station code 0 = no link partner reception of local station code	RO	X
5.13	Remote fault	1 = remote wire fault detected 0 = no remote wire fault detected	R/W	X
5.12-5.10	Reserved	<i>(Not used at present)</i>		X
5.9	100BASE-T4 capability	1 = 100BASE-T4 capability 0 = no 100BASE-T4 capability	R/W	X
5.8	100BASE-TX full duplex	1 = 100BASE-TX full duplex capability 0 = no 100BASE-TX full duplex	R/W	X
5.7	100BASE-TX	1 = 100BASE-TX capability 0 = no 100BASE-TX capability	R/W	X
5.6	10BASE-T full duplex	1 = 10BASE-T full duplex capability 0 = no 10BASE-T full duplex capability	R/W	X
5.5	10BASE-T	1 = 10BASE-T capability 0 = no 10BASE-T capability	R/W	X
5.4-5.1	Selector field	All these bits are 0 for 802.3 LANs	RO	X
5.0	Selector field	This bit is a 1 for 802.3 LANs	RO	X

Table 5. Link Partner Register

BIT(S)	NAME	DESCRIPTION	R/W	DEFAULT
6.15-6.5	Reserved; not used			0
6.4	Multiple link fault	1 = more than one receiving protocol indicates link OK 0 = no multiple link faults	RO; reset on read	0
6.3	Link partner next page able	1 = link partner supports next page 0 = link partner has no next page	RO	0
6.2	Next page able	1 = local port supports next page 0 = local port has no next page	RO	0
6.1	Page received	1 = 3 identical, consecutive link code words received 0 = 3 identical, consecutive link code words NOT received	RO; reset on read	0
6.0	Link partner auto neg. capable	1 = link partner has auto negotiation capability 0 = link partner has NO auto negotiation capability	RO	0

NOTE: All unnamed or unused register locations will return 0 values when accessed.

KEY: LL = latch low until read, R/W = read/write, RO = read only, SC = self-clearing.

Table 6. Expansion Register



## ML6692 SCHEMATIC

Figure 8 shows a general 10BASE-T and 100BASE-TX design using the ML2653 (10BASE-T PHY) and ML6692 (100BASE-TX PHY).

The inductors L1 and L2 are for the purpose of improving return loss. Capacitor C7 is recommended. It decouples some noise at the inputs of the ML6692, and improves the Bit Error Rate (BER) performance of the board. We

recommend having a 0.1 $\mu$ F Cap on every  $V_{CC}$  pin as indicated by C3, 4, 9-12. Also, we recommend splitting the  $AV_{CC}$ , AGND and DGND. It is recommended that AGND and DGND planes are large enough for low inductance. If splitting the two grounds and keeping the ground planes large enough is not possible due to board space, you could join them into one larger ground plane.

## ML6692 PARTS LIST

COMPONENT	DESCRIPTION
U1	ML6692 52-Pin PLCC surface mount
U2	Can Crystal Oscillator, 25MHz 4-pin surface mount
U3	ML2653 28-pin PLCC surface mount
U4	93LC46 8-pin PLCC surface mount EEPROM
U5	BEL Transformer Module 5558-1287-02, or XFMRS Inc. XF6692TX, or Valor ST6129 (not pin compatible)
U6	HEX Inverter 74HC04
X1	20MHz XTAL surface mount
FB1, FB2	Fair-Rite SM Bead P/N 2775019447
L1, L2	130nH inductors rated at 50MHz
R1	2.49k $\Omega$ 1% 1/8W surface mount
R2	9.53k $\Omega$ 1% 1/8W surface mount
R3, R12, R24, R25	750 $\Omega$ 5% 1/8W surface mount
R4, R5*	34.0 $\Omega$ 1% 1/8W surface mount
R6	23.7 $\Omega$ 1% 1/4W surface mount
R7	40.2k $\Omega$ 1% 1/8W surface mount
R8, R9, R26	200 $\Omega$ 1% 1/8W surface mount
R10, R11	100 $\Omega$ 1% 1/8W surface mount
R13, R14	100k $\Omega$ 10% 1/8W surface mount
R15–R20	49.9 $\Omega$ 5% 1/8W surface mount
R21, R22	75 $\Omega$ 5% 1/8W surface mount
R23	75 $\Omega$ 1% 1/4W surface mount
C1, C3, C4,	0.1 $\mu$ F Ceramic Chip Cap
C8-12, C15	0.01 $\mu$ F Ceramic Chip Cap
C5, C6	10 $\mu$ F Tantalum Cap.
C7	10pF Cap
C2	Board layer Cap (2V rated)
C13, C14	22nF Cap
D1-D4	LED Diodes

Refer to ML2653 data sheet for CS2, CS1, and CS0 configuration

\* These resistors need to be tuned to provide a 500mV<sub>p-p</sub> amplitude single ended signal to the ML6692 inputs.

PHYSICAL DIMENSIONS inches (millimeters)

Package: Q52  
52-Pin PLCC

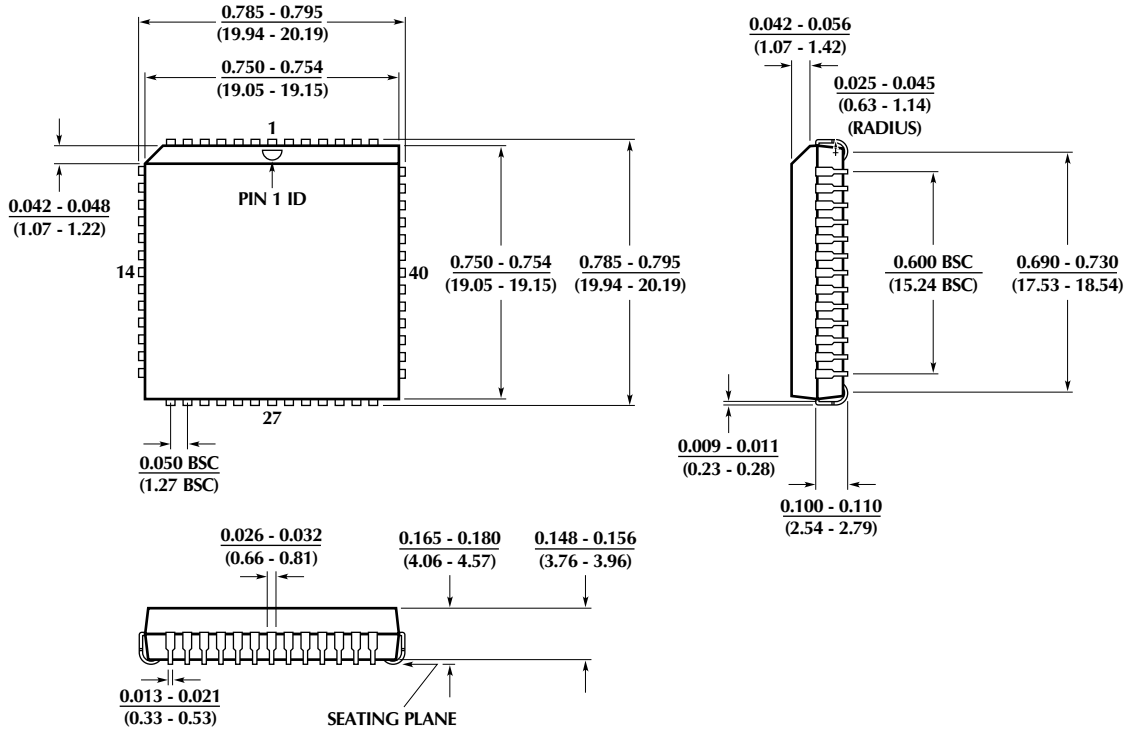

Package: H64-10  
64-Pin (10 x 10 x 1mm) TQFP

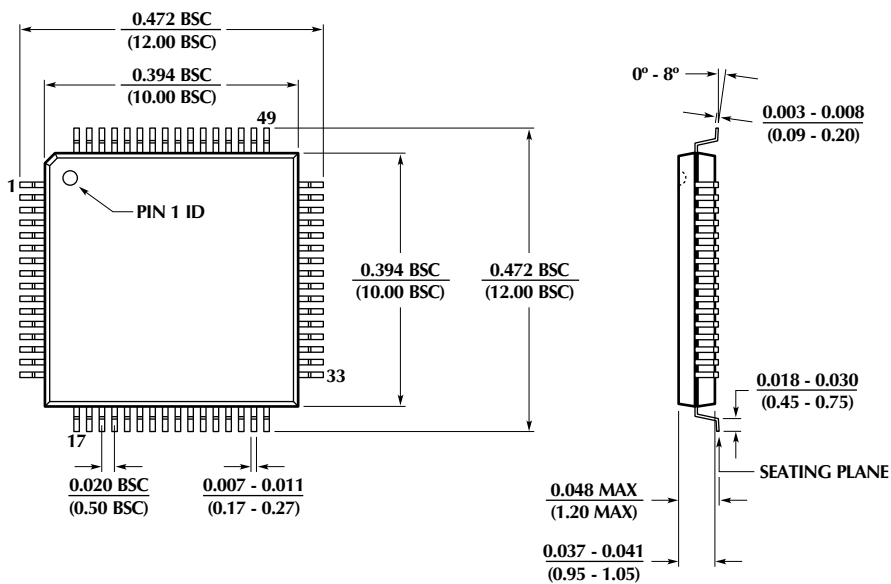

**PHYSICAL DIMENSIONS** inches (millimeters)**ORDERING INFORMATION**

PART NUMBER	TEMPERATURE RANGE	PACKAGE
ML6692CH	0°C - 70°C	64 Pin Thin Quad Flat Pack (TQFP)
ML6692CQ	0°C - 70°C	52 Pin Plastic Leaded Chip Carrier (PLCC)

Micro Linear makes no representations or warranties with respect to the accuracy, utility, or completeness of the contents of this publication and reserves the right to make changes to specifications and product descriptions at any time without notice. No license, express or implied, by estoppel or otherwise, to any patents or other intellectual property rights is granted by this document. The circuits contained in this document are offered as possible applications only. Particular uses or applications may invalidate some of the specifications and/or product descriptions contained herein. The customer is urged to perform its own engineering review before deciding on a particular application. Micro Linear assumes no liability whatsoever, and disclaims any express or implied warranty, relating to sale and/or use of Micro Linear products including liability or warranties relating to merchantability, fitness for a particular purpose, or infringement of any intellectual property right. Micro Linear products are not designed for use in medical, life saving, or life sustaining applications.

© Micro Linear 2000.  **Micro Linear** is a registered trademark of Micro Linear Corporation. All other trademarks are the property of their respective owners.

Products described herein may be covered by one or more of the following U.S. patents: 4,897,611; 4,964,026; 5,027,116; 5,281,862; 5,283,483; 5,418,502; 5,508,570; 5,510,727; 5,523,940; 5,546,017; 5,559,470; 5,565,761; 5,592,128; 5,594,376; 5,652,479; 5,661,427; 5,663,874; 5,672,959; 5,689,167; 5,714,897; 5,717,798; 5,742,151; 5,747,977; 5,754,012; 5,757,174; 5,767,653; 5,777,514; 5,793,168; 5,798,635; 5,804,950; 5,808,455; 5,811,999; 5,818,207; 5,818,669; 5,825,165; 5,825,223; 5,838,723; 5,844,378; 5,844,941. Japan: 2,598,946; 2,619,299; 2,704,176; 2,821,714. Other patents are pending.

2092 Concourse Drive  
San Jose, CA 95131  
Tel: (408) 433-5200  
Fax: (408) 432-0295  
www.microlinear.com