

# Protection of Lithium Ion Batteries (two cells in series) Monolithic IC MM1292

## Outline

This IC is for protecting a lithium ion battery from overcharging, excess discharging, and overcurrent. If abnormalities occur during charging and excess voltage is applied, it has a function that turns off the external FET switch when voltage is applied to each battery beyond a specified time (overcharging detection). It also has a function that turns off the external FET switch when the voltage for each battery falls below a set voltage, to prevent excess discharge when discharging the battery (discharging detection). At that time, the IC is switched to low current consumption mode. Also, when there is a large current flow due to shorting or other reasons, there is a function for turning off the external FET switch (overcurrent detection).

These functions comprise a protection circuit, with few external parts, for lithium ion batteries.

## 2-Cell Protection ICs

Model name	Overcharge protection		Overdischarge protection		Overcurrent
	Detection voltage	Hysteresis	Detection voltage	Hysteresis	Detection voltage
MM1302A	4.25±0.05V	10mV	2.3V±0.1V	700mV	220±20mV
MM1292C	4.25±0.05V	200mV	2.4V±0.1V	600mV	150±15mV
MM1292D	4.35±0.05V	200mV	2.4V±0.1V	600mV	150±15mV
MM1302E	4.10±0.05V	10mV	2.4V±0.1V	600mV	150±15mV
MM1302F	4.35±0.05V	10mV	None		None
MM1302G	4.215±35V	10mV	2.3V±0.1V	700mV	220±20mV
MM1292H	4.30±0.05V	220mV	2.05V±0.1V	950mV	170±15mV
MM1292J	4.25±0.05V	220mV	2.4V±0.1V	600mV	150±15mV
MM1292K	4.25±0.05V	220mV	2.4V±0.1V	600mV	150±15mV
MM1292L	4.25±0.05V	220mV	2.2V±0.1V	800mV	100±10mV

## Features

1. Current consumption (during overcharging)	V <sub>CELL</sub> =4.5V	80µA typ.
2. Current consumption (normal)	V <sub>CELL</sub> =3.5V	13µA typ.
3. Current consumption (during excess discharging)	V <sub>CELL</sub> =1.9V	0.5µA typ.
4. Current consumption (during excess discharging)	V <sub>CELL</sub> =1.0V	0.1µA max.
5. Overcharge detection voltage (Ta=-20°C~+70°C)		4.25V±50mV (detection for each cell)
6. Hysteresis voltage		200mV±60mV (detection for each cell)
7. Excess discharge detection voltage		2.4V±0.1V (detection for each cell)
8. Discharge resumption voltage		3.0V±0.1V (detection for each cell)
9. Overcurrent detection voltage		150mV±15mV
10. Reset after overcurrent detection		load release
11. Operating limit voltage		0.9V max.

## Package

SOP-8C, SOP-8D(MM1292□F)

\*The box represents the rank resulting from the combination of protection functions.

## Applications

1. Cellular phones
2. Movies

## Pin Assignment

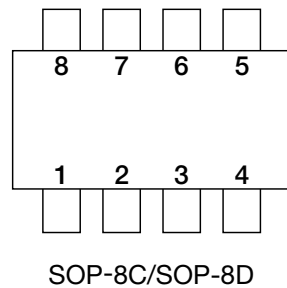

1	OC
2	GD
3	N.C
4	GND
5	TD
6	VL
7	CS
8	VH

## Pin Description

Pin No.	Pin	Output	Function
1	OC	Output	Output pin for control of the charging control FET. When voltage detected between VH-VL or VL-GND goes over overcharge detection voltage (VALM), the output PNP-TR (open collector output) is switched ON, and charging is prohibited by activating the element (NPN-TR, or N-ch FET) that switches the charging control FET to OFF. This operation continues until the voltage falls below VALM.
2	GD	Output	Output pin for driving the discharge control FET. When voltage detected between VH-VL and VL-GND goes over excess discharge voltage (VS), this pin goes H. When voltage detected between VH-VL and VL-GND falls below VS and the voltage between CS-GND is more than the voltage detected for an overcurrent (VCS), it goes L.
3	DS	Input	Input pin for discharge detection. When voltage between DS-GND during charge detection exceeds discharge detection voltage (VDS), OC output is switched OFF and charge control FET is switched ON.
4	GND	Input	Negative connection pin for the low side battery. It is also the GND pin for this IC. (The IC's reference power supply pin.)
5	TD	Input	Over charge detection output non-induction time setting pin. The capacitor connected between TD-GND is charged with constant current (ITC) during over charging. When TC pin voltage exceeds the threshold value (VTC), OC output is switched ON.
6	VL	Input	Positive connection pin for the low side battery, and negative connection pin for the high side battery.
7	CS	Input	Overcurrent detection pin during discharge, and charging detection pin during power down. It detects discharge current using the source drain voltage (voltage between CS-GND) of discharge control FET. Also, when the battery is charged with a current whose CS-GND voltage after power down exceeds the start-up voltage (VST), the bias current is drained to the interior circuit and operating status results.
8	VH	Input	Positive connection pin for the high side battery, and the IC's current input pin.

Block Diagram

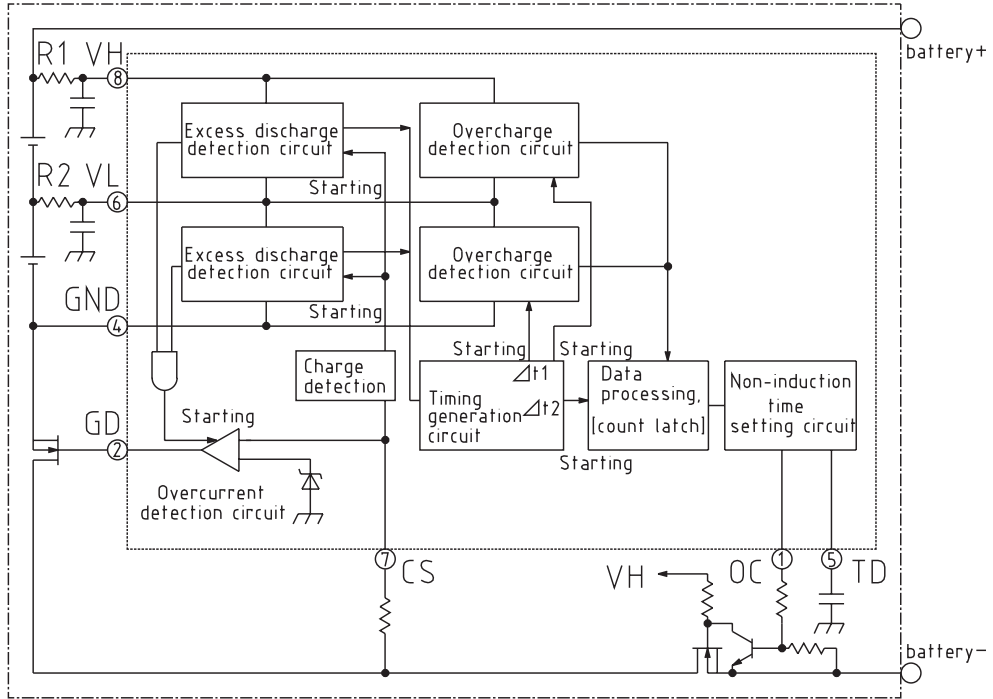

Note 1. 45µA max. (current consumption during operation of overcharge detection section) flows to input protection resistor R1.

Note 2. 0.3µA max. (when cells are balanced) flows to input protection resistor R2. When the cells are not balanced, the current increases to wards correction.

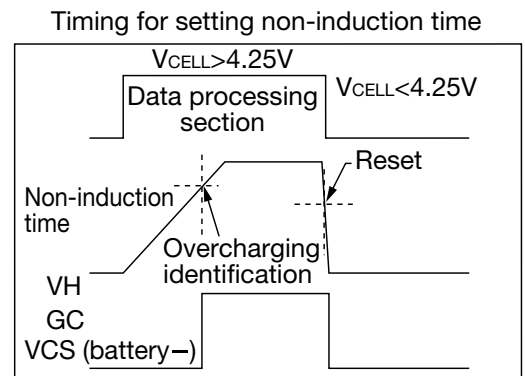
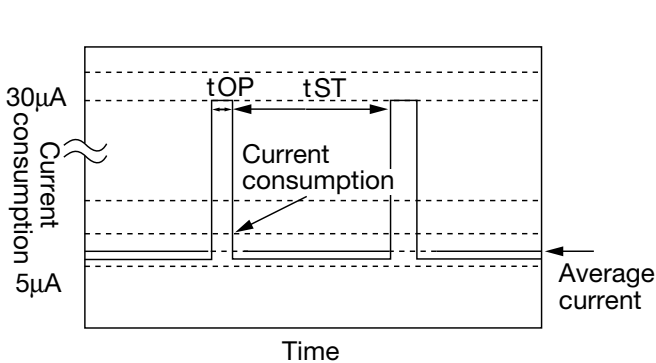
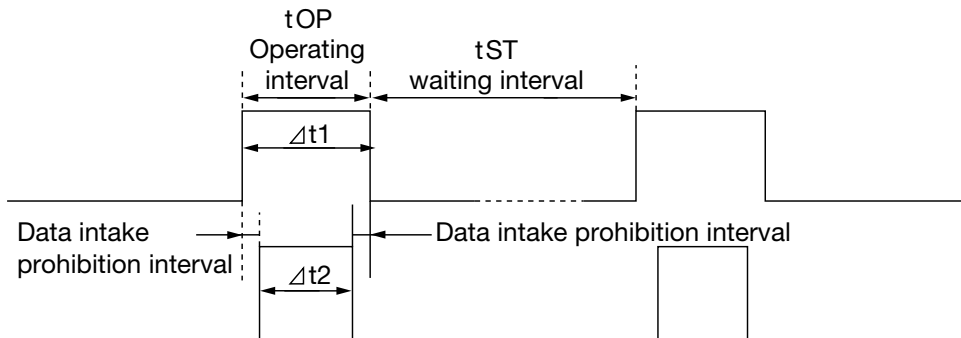

Timing Chart

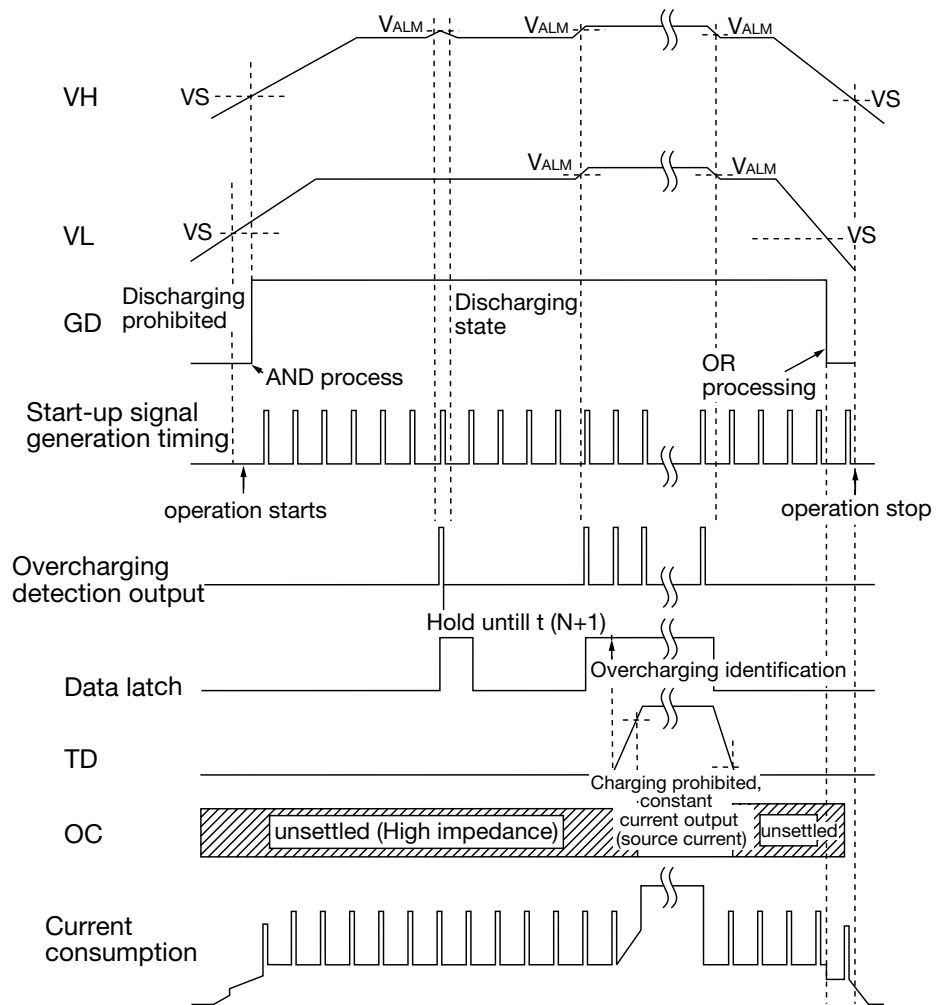

Absolute Maximum Ratings

Item	Symbol	Rating	Units
Storage temperature	T <sub>STG</sub>	-40~+125	°C
Operating temperature	T <sub>OPR</sub>	-20~+70	°C
Power supply voltage	V <sub>OC max.</sub>	-0.3~18	V
OC pin applied voltage	V <sub>OVOUT</sub>	-10~V <sub>H</sub>	V
CS pin applied voltage	V <sub>DCOUT</sub>	-0.6~V <sub>H</sub>	V
Allowable power dissipation	P <sub>d</sub>	300	mA

**Electrical Characteristics** (unless otherwise specified, Ta=25°C)

Item	Symbol	Measurement Conditions	Min.	Typ.	Max.	Units
Current consumption 1	I <sub>VH1</sub>	V <sub>CELL</sub> =4.5V, R <sub>OC</sub> =270kΩ		80	100	μA
Current consumption 2	I <sub>VH2</sub>	V <sub>CELL</sub> =3.5V (normal)		13.0	20.0	μA
Current consumption 3	I <sub>VH3</sub>	V <sub>CELL</sub> =1.9V (During excess discharge)		0.5	0.8	μA
Current consumption 4	I <sub>VH4</sub>	V <sub>CELL</sub> =1.0V (During excess discharge)			0.1	μA
VL pin input voltage	I <sub>VL</sub>	V <sub>H</sub> =V <sub>L</sub>	-0.3	0	0.3	μA
Overcurrent detection voltage	V <sub>ALM</sub>	Ta=-20°C~70°C	4.20	4.25	4.30	V
Hysteresis voltage	ΔV <sub>AL</sub>	ΔV <sub>AL</sub> =V <sub>ALMH</sub> -V <sub>ALML</sub>	140	200	260	mV
Overcharge detection voltage	V <sub>S</sub>		2.30	2.40	2.50	V
Discharge resumption voltage	V <sub>DF</sub>	Discharge resumed through voltage rise	2.90	3.00	3.10	V
Starting voltage	V <sub>ST</sub>	Voltage applied between GND-CS pins	-0.6	-0.5		V
GD pin output voltage H	V <sub>GDH</sub>	V <sub>CELL</sub> =3.5V, I <sub>L</sub> =10μA	V <sub>H</sub> -0.3	V <sub>H</sub> -0.2		V
GD pin output voltage L	V <sub>GDL</sub>	V <sub>CELL</sub> =3.5V, I <sub>L</sub> =10μA, V <sub>CS</sub> =1V		0.2	0.3	V
OC pin output current	I <sub>oCH</sub>	V <sub>CELL</sub> =4.5V	20	150		μA
Overcurrent detection voltage	V <sub>CS</sub>		135	150	165	mV
Reset by overcurrent			load release			
Overcurrent detection delay 1	T <sub>oc1</sub>		10	20		mS
Overcurrent detection delay 2	T <sub>oc2</sub>	between CS-GND pins > 0.8V		30	100	μS
Excess discharge detection delay	T <sub>OD</sub>		10	20		mS
TC pin charge current	I <sub>TC1</sub>		30	50	80	nA
TC pin threshold value	V <sub>TC</sub>	V <sub>CELL</sub> =4.5V, V <sub>TC</sub> =0→5V V <sub>OC</sub> =L→H	3.65	3.90	4.15	V
Non-induction time for overcharge	T <sub>OC</sub>	C <sub>TC</sub> =0.012μF	0.5	1.0	1.5	S
Operating limit voltage	V <sub>OPL</sub>				0.9	V

- Note 1. For current consumption, it is assumed that high side cell voltage and low side cell voltage are identical. When the cell voltages differ, it is set by the higher voltage.
2. GD pin are high impedance when the current consumption is below the operating limit voltage.
3. When the circuit configuration calls for discharge resumption through charging, the discharge resumption voltage is 2.4V typ.

**Description of Operation**

[Outline]

This IC is used for protecting lithium ion batteries (two cell series connection type). Overcharge detection, excess discharge detection, and overcurrent detection are built into each circuit. It controls the FET for discharge control and charge control (external N-MOS FET). There are four major operating modes.

1. Overcharge mode  
When the voltage between V<sub>H</sub>-V<sub>I</sub> and V<sub>I</sub>-GND exceeds the overcharge voltage (V<sub>ALM</sub>).
2. Normal mode  
When the voltage between V<sub>H</sub>-V<sub>I</sub> and V<sub>I</sub>-GND exceeds the excess discharge voltage (V<sub>S</sub>) and is less than the over charge voltage (V<sub>ALM</sub>).
3. Excess discharge mode  
When the voltage between V<sub>H</sub>-V<sub>I</sub> and V<sub>I</sub>-GND is less than the excess discharge voltage (V<sub>S</sub>).
4. Overcurrent mode  
When the voltage between CS-GND is less than the overcurrent voltage (V<sub>CS</sub>).

[Operation]

1. Excess discharge detection circuit

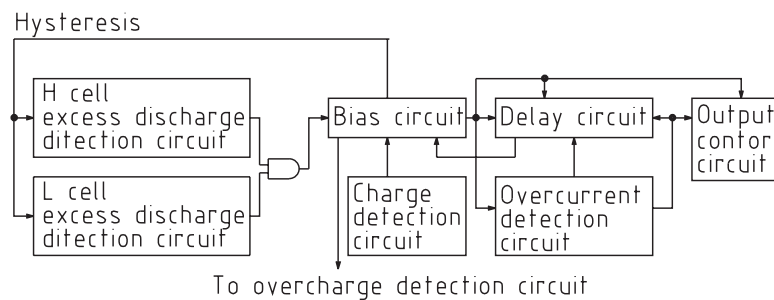

The H cell excess discharge detection circuit monitors the voltage between  $V_H$ - $V_L$ , while the L cell excess discharge detection circuit monitors the voltage between  $V_L$ - $GND$ . When the voltage between  $V_H$ - $V_L$  and  $V_L$ - $GND$  exceeds  $V_S$ , the operating state is maintained with bias current supplied from the bias circuit to the delay circuit, the output control circuit, the overcurrent detection circuit, and the overcharge detection circuit. When the battery current for either the H or L cell falls below  $V_S$ , the current from the excess discharge detection circuit to the bias circuit is switched off. Also, the capacitor connected to the delay circuit's comparator (COD) input pin is charged using constant current. When this falls below the COD's reference input potential, the bias current to output control and current to the bias circuit are switched off.

The excess discharge delay time ( $t_{OD}$ ) is set by the delay circuit and cannot be modified externally. When the bias circuit is in waiting mode, the hysteresis loop to the excess discharge detection circuit is switched off, and the detection voltage of the excess discharge detection circuit becomes discharge resumption voltage ( $V_{DCH}$ ). When the battery is being charged and the voltage between  $CS$ - $GND$  during excess discharge mode falls below  $V_{ST}$ , however, start-up current is supplied to the bias circuit, and the hysteresis loop of the excess discharge detection circuit is connected. Therefore, the excess discharge detection circuit detection voltage becomes  $V_S$ . Also, the overcharging detection circuit goes into waiting mode, so overcharging detection does not occur in overcharging mode.

When the cell voltage of either the H or L cell exceeds  $V_{ALM}$  (one is excess discharging and the other is overcharging), the bias current is maintained in the overcharging detection circuit. Therefore, the overcharging is maintained until the current falls below  $V_{ALM}$ .

2. Overcharging Detection Circuit

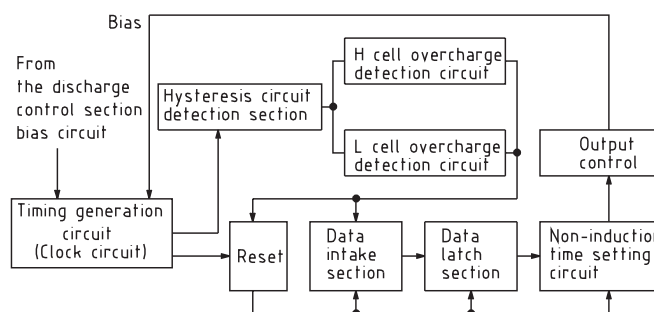

The timing (clock) for the waiting interval and operating interval is created by the timing generation circuit. In normal mode, the only blocks operating during the waiting interval are the input stages for the timing generation circuit and the data intake section. Other blocks operate only during the operation interval. The operation interval and the waiting interval are set at a ratio of 1:10, reducing power consumption. The voltage detection resistance of the overcharge detection circuit is switched on and off by the detection section's SW circuit. Therefore, current does not flow to detection resistors during waiting time, resulting in low current consumption during excess discharge mode.

(Operating sequence)

Bias current is supplied to the timing generation circuit and data intake section by the bias circuit of the excess discharge detection section during normal mode.

The operation interval and the waiting interval are created by the timing generation circuit. During the operation interval, bias current is supplied to the excess charging detection circuit, and cell voltages of both the H and L cells are monitored.

When the cell voltage of either the H or L cell exceeds  $V_{ALM}$ , an overcharge detection signal is output to the data intake section, and a reset signal is prohibited from going to the data processing section.

When more than two consecutive clocks of the excess charging detection signal are input to the data intake section, a determination is made that the overcharging detection signal has been properly input, and it is output to the next stage. This prevents noise and mistaken determinations of overcharging caused by excess cell voltage fluctuation.

When the data intake section outputs the overcharging detection signal, the data charge section goes into operation. When more than two clocks of overcharging signals are input, this activates the latch on the overcharging signal.

When the overcharging signal latch in the data latch section is activated, the next non-induction time circuit goes into operation. When this operates, the TD pin is charged by constant current (ITC). The TD pin potential and the threshold value ( $V_{TC}$ ) are compared by the non-induction time circuit comparator. When TD pin voltage exceeds  $V_{TC}$ , the OC pin output stage becomes operable and OC pin output PNP-TR (open collector) is switched on. Also, bias current is supplied to the timing generation circuit and the operation of the overcharging detection circuit is maintained.

When discharge occurs during overcharge mode ( $GND < DS$  pin), the discharge detection circuit charges the TD pin and non-induction time is reset.

When cell voltage falls below  $V_{ALM}$  and the overcharging detection circuit signal is off, the reset prohibition is lifted. The reset signal is sent to the data intake and data latch sections and the non-induction time circuit, and normal mode is reinstated.

A diode is built in between the OC pin and GND. When OC pin potential falls below GND terminal  $V_F$ , current flows from the OC pin.

Therefore, when battery pack voltage  $\ll$  charging voltage (charging device), charging is immediately prohibited. (Generation conditions for the above mode vary depending on the external constant.)

### 3. Overcurrent Detection Circuit

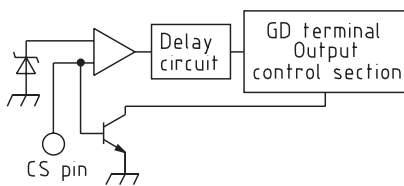

CS-GND Voltage	Mode	Delay Time
Below $V_{cs}$	Normal Mode	-
$V_{cs} \sim V_F$	Overcurrent Mode (Normal)	$t_{oc1}$
Above $V_F$	Overcurrent Mode (Short)	$t_{oc2}$

( $V_F$  : Voltage between built-in NPN-TR and base emitter)

The overcurrent detection circuit operates during overcharging. Load current detects current flowing on FET equivalently, by monitoring the voltage between discharge control FET drain sources using the voltage between CS-GND. (Monitoring of voltage drop using FET ON resistor load current.)

There are two modes for overcurrent detection : the normal mode and the short mode.

In normal mode, when voltage between CS-GND is equal to that between  $V_{cs} - V_f$ , overcharging detection output at this time is input to the internal delay circuit. When overcurrent detection continues for longer than overcurrent delay time 1 ( $t_{OC1}$ ), overcurrent mode is activated, and GD pin output goes L. (Discharge control FET ON)

In short mode, when the voltage between CS-GND exceeds  $V_F$ , the overcurrent mode operates without going through the delay circuit. The delay time is determined by the internal circuit operating speed (Overcurrent delay time 2 [ $t_{OC2}$ ], so the flow of overcurrent to the discharge control FET is for a short duration, limiting stress on the FET.)

The  $V_F$  has a temperature factor of  $-2mV/C$ , so the switching level between normal and short mode varies with the ambient temperature.

The overcurrent detection voltage ( $V_{cs}$ ) is fixed, so the current value for overcurrent detection changes according to discharge control FET ON resistance. Therefore, select an FET that conforms to the detection current. FET ON resistance is highly sensitive to temperature, due to overcurrent detection voltage, and the detection current changes due to FET heat emission resulting from ambient temperature and load current. In addition, users should be aware that FET ON resistance also changes due to the voltage between FET gate sources. (ON resistance rises when the voltage between gate sources falls.)

Load release resets from overcurrent mode.