

TOSHIBA BIPOLAR LINEAR INTEGRATED CIRCUIT SILICON MONOLITHIC

# TA7523S

## SINGLE COMPARATOR

TA7523S is comparator with wide range single or two supply voltage. Output is open collector and wired-OR possible.

### FEATURES

- Wide Common Mode Input Voltage :  $0V \sim V_{CC} - 1.5V$
- Output is Compatible with TTL and CMOS.
- With Two Output Terminal (OUT,  $\overline{OUT}$ )
- Hysteresis Voltage Width is Variable by External Resistor.
- Wide Supply Voltage Range :  $2V \sim 36V$  or  $\pm 1V \sim \pm 18V$

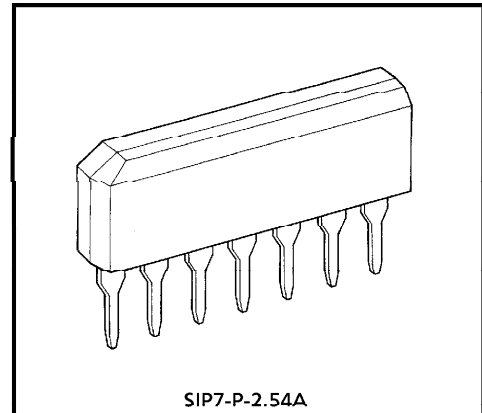

SIP7-P-2.54A

Weight : 0.7g (Typ.)

### PIN CONNECTION

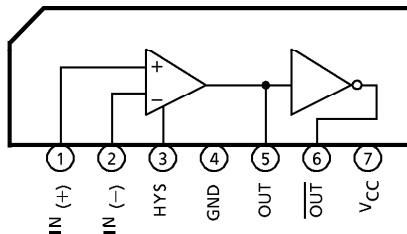

961001EBA1

- TOSHIBA is continually working to improve the quality and the reliability of its products. Nevertheless, semiconductor devices in general can malfunction or fail due to their inherent electrical sensitivity and vulnerability to physical stress. It is the responsibility of the buyer, when utilizing TOSHIBA products, to observe standards of safety, and to avoid situations in which a malfunction or failure of a TOSHIBA product could cause loss of human life, bodily injury or damage to property. In developing your designs, please ensure that TOSHIBA products are used within specified operating ranges as set forth in the most recent products specifications. Also, please keep in mind the precautions and conditions set forth in the TOSHIBA Semiconductor Reliability Handbook.
- The products described in this document are subject to foreign exchange and foreign trade control laws.
- The information contained herein is presented only as a guide for the applications of our products. No responsibility is assumed by TOSHIBA CORPORATION for any infringements of intellectual property or other rights of the third parties which may result from its use. No license is granted by implication or otherwise under any intellectual property or other rights of TOSHIBA CORPORATION or others.
- The information contained herein is subject to change without notice.

EQUIVALENT CIRCUIT

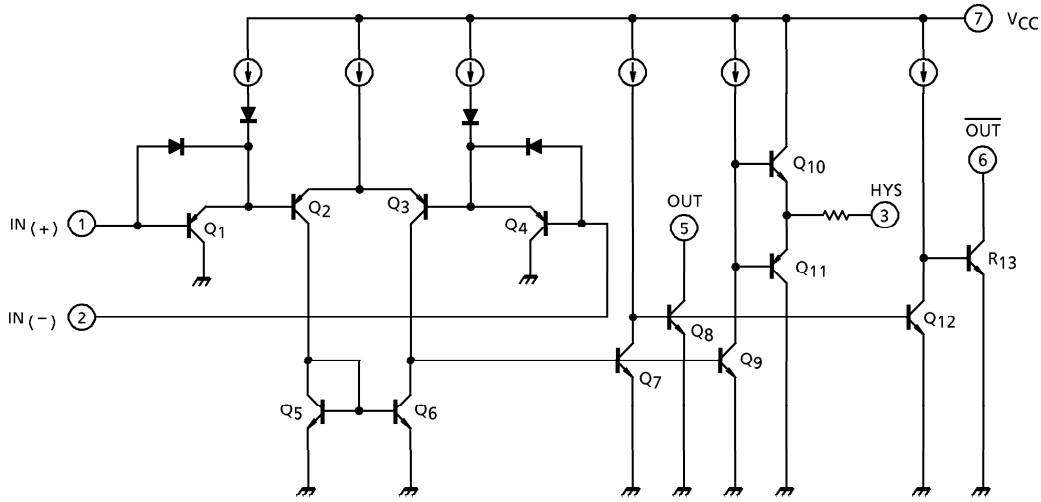

MAXIMUM RATINGS (Ta = 25°C)

CHARACTERISTIC	SYMBOL	RATING	UNIT
Supply Voltage	V <sub>CC</sub>	± 18 or 36	V
Differential Input Voltage	DV <sub>IN</sub>	± 36	V
Common Mode Input Voltage	CMV <sub>IN</sub>	- 0.3~V <sub>CC</sub>	V
Power Dissipation	P <sub>D</sub>	500	mW
Operating Temperature	T <sub>opr</sub>	- 40~85	°C
Storage Temperature	T <sub>stg</sub>	- 55~125	°C

ELECTRICAL CHARACTERISTICS (V<sub>CC</sub> = 5V, Ta = 25°C)

CHARACTERISTIC	SYMBOL	TEST CIRCUIT	TEST CONDITION	MIN.	TYP.	MAX.	UNIT
Input Offset Voltage	V <sub>IO</sub>	4	—	—	3	7	mV
Input Bias Current	I <sub>I</sub>	2	—	—	25	250	nA
Input Offset Current	I <sub>IO</sub>	2	—	—	5	50	nA
Common Mode Input Voltage	CMV <sub>IN</sub>	4	—	0	—	V <sub>CC</sub> - 1.5	V
Voltage Gain	G <sub>V</sub>	—	R <sub>L</sub> = 15kΩ	—	200	—	V / mV
Supply Current	I <sub>CC</sub>	1	No Load	—	0.5	3	mA
Sink Current	I <sub>SINK</sub>	5	IN (+) = 0V, IN (-) = 1V, V <sub>OL</sub> = 1.5V	6	16	—	mA
Output Voltage	V <sub>OL</sub>	5	IN (+) = 0V, IN (-) = 1V, I <sub>SINK</sub> = 3mA	—	0.2	0.4	V
Output Leak Current	I <sub>LEAK</sub>	3	IN (+) = 1V, IN (-) = 0V, V <sub>O</sub> = 5V	—	0.1	—	nA
Response Time	t <sub>rsp</sub>	6	R <sub>L</sub> = 5.1kΩ, C <sub>L</sub> = 15pF	—	1.3	—	μs

TEST CIRCUIT

(1)  $I_{CC}$

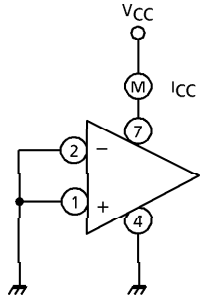

(2)  $I_I, I_{IO}$

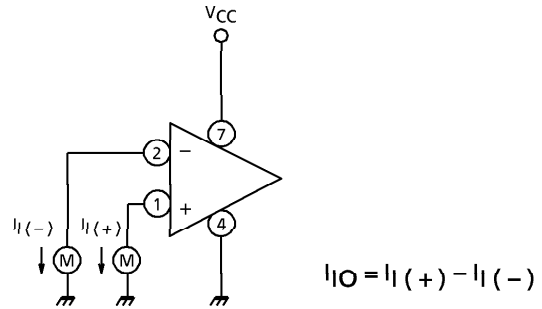

(3)  $I_{LEAK}$

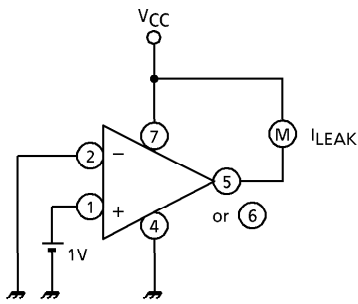

(4)  $V_{IO}, CMV_{IN}$

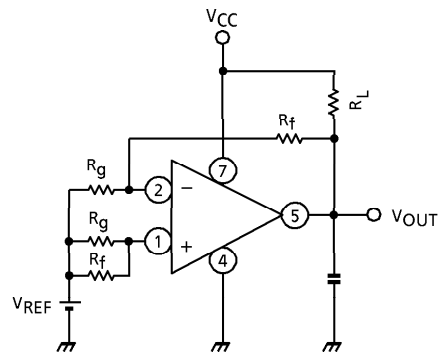

(5)  $I_{sink}, V_{OL}$

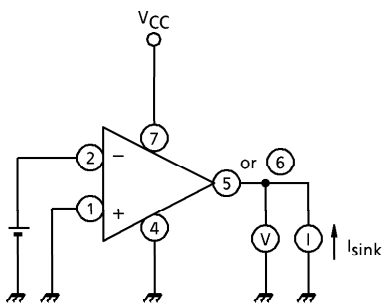

(6)  $t_{rsp}$

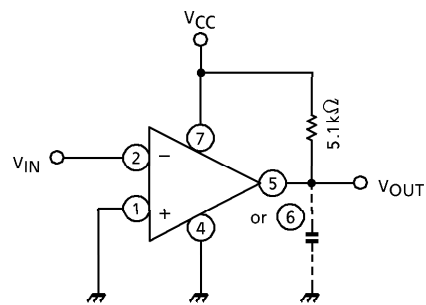

APPLICATION CIRCUIT

1. GENERAL COMPARATOR

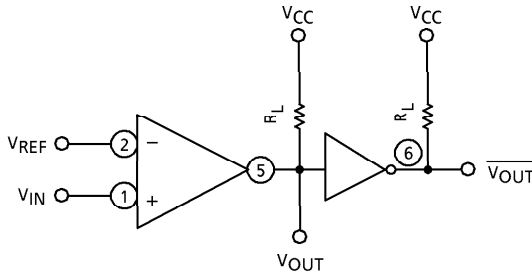

2. COMPARE WITH INPUT VOLTAGE

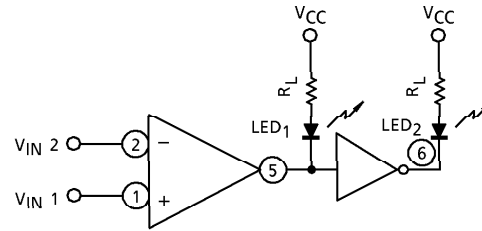

LED<sub>2</sub> IS LIGHTED AT V<sub>IN 1</sub> > V<sub>IN 2</sub>  
 LED<sub>1</sub> IS LIGHTED AT V<sub>IN 1</sub> < V<sub>IN 2</sub>

3. COMPARATOR WITH HYSTERESIS

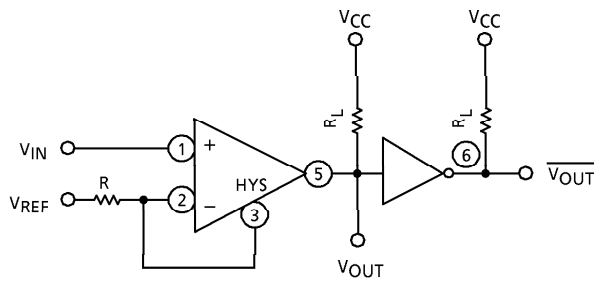

- VOH : OUTPUT VOLTAGE ("H" LEVEL)
- VOL : OUTPUT VOLTAGE ("L" LEVEL)
- VIN⊕ : TURNOVER INPUT VOLTAGE ("H" LEVEL)
- VIN⊖ : TURNOVER INPUT VOLTAGE ("L" LEVEL)
- VREF : REFERENCE VOLTAGE
- ΔV : HYSTERESIS WIDTH

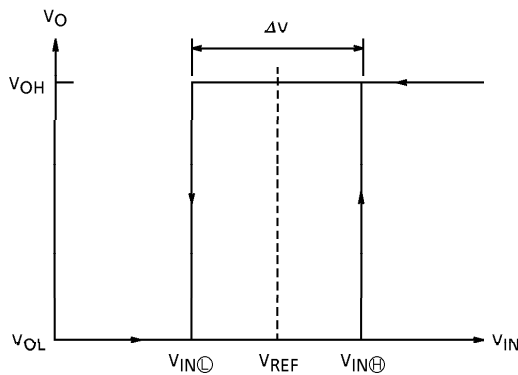

Calculate the Hysteresis width using the following equation

$$\Delta V \cong (V_{CC} - 2) \frac{R}{R + 10} \quad V_{CC} (V) \quad R (k\Omega)$$

CHARACTERISTICS

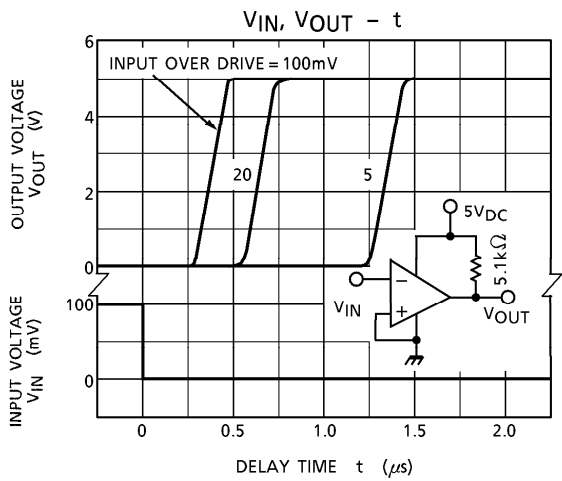
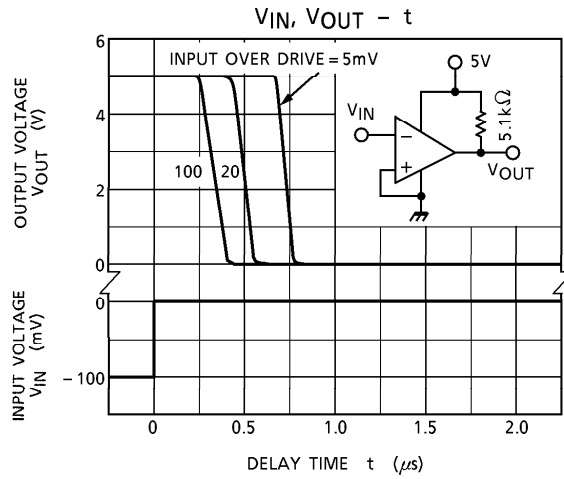
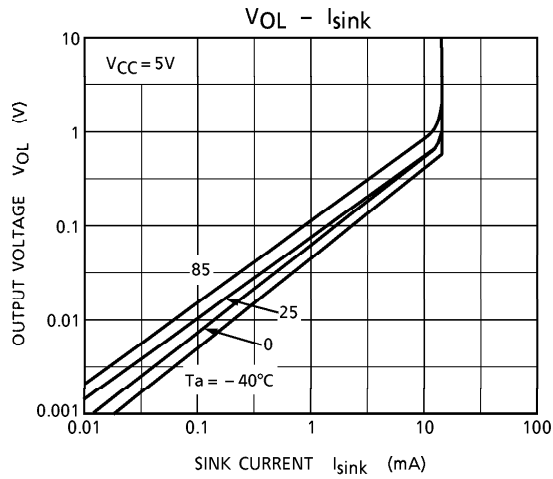
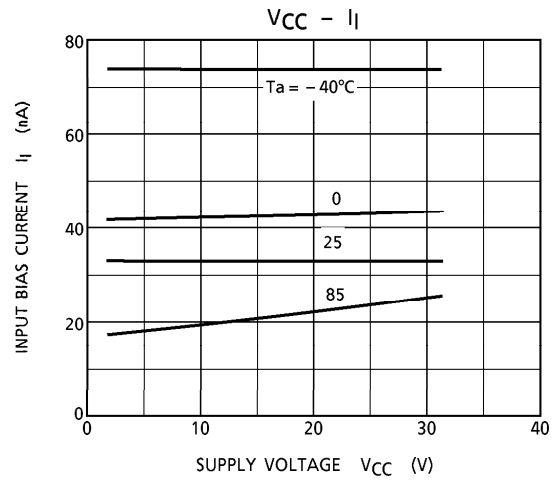
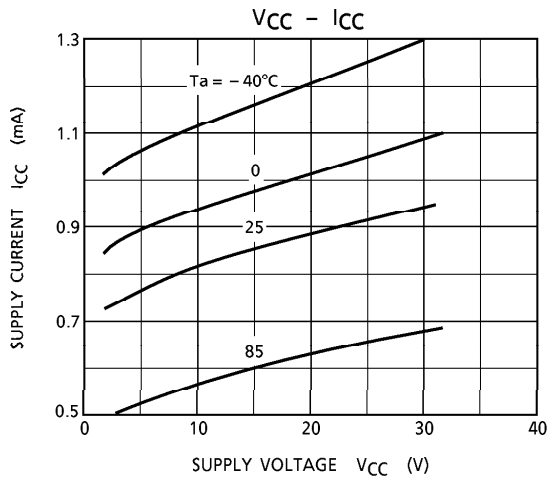

OUTLINE DRAWING  
SIP7-P-2.54A

Unit : mm

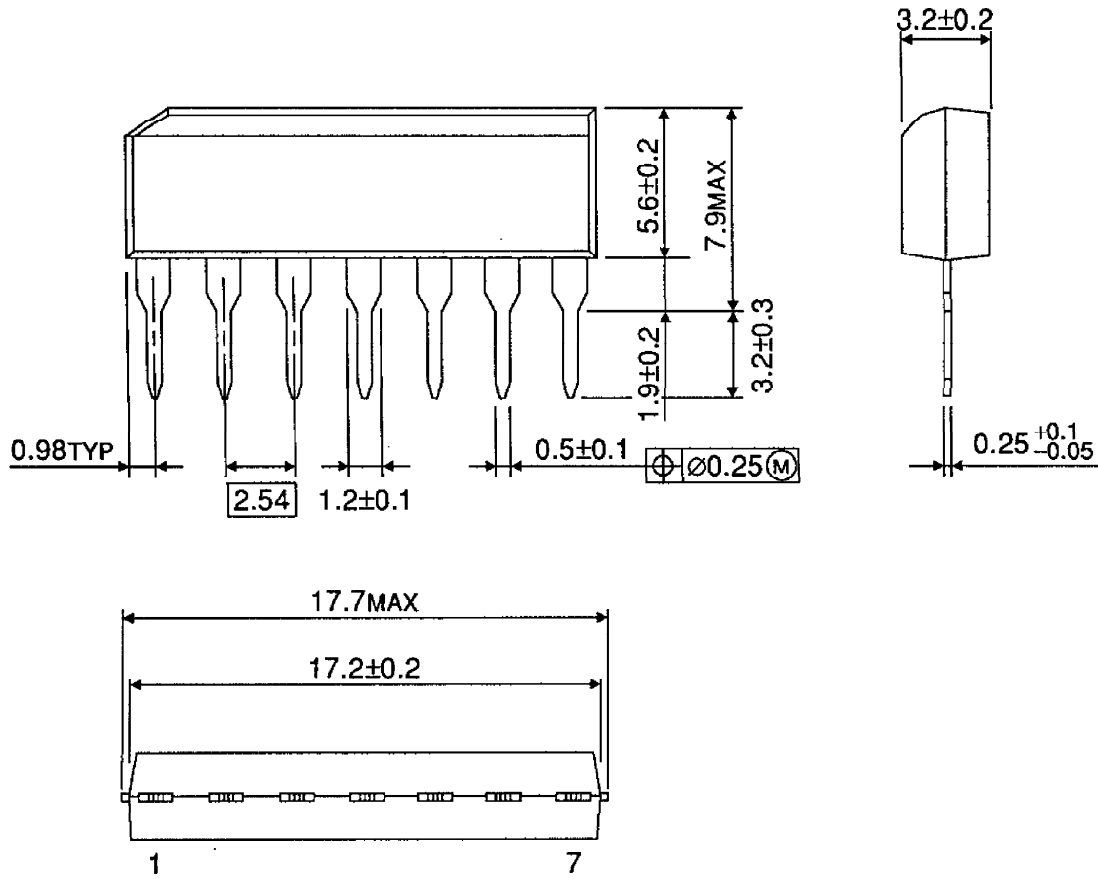

Weight : 0.7g (Typ.)