

**PRELIMINARY**  
 Notice: This is not a final specification.  
 Some parametric limits are subject to change.

MITSUBISHI Dig./Ana.INTERFACE

# M62706ML,SL

VOLTAGE DETECTING, SYSTEM RESETTNG IC SERIES

## GENERAL DESCRIPTION

The M62703ML/SL is a voltage threshold detector designed for detection of a supply voltage and generation of a system reset pulse for almost all logic circuits such as microcontroller.

It has extensive applications including battery checking, level detecting and waveform shaping circuits.

## FEATURES

- Few external components
- Low operating threshold voltage (Supply voltage to keep a output low in a low supply operation)  
 ...0.65V(typ) at  $R_L = 22k$
- Wide supply voltage range ..... 2V to 7V
- High immunity to a sudden supply voltage change
- Wide application range
- Extra small 3-pin package (3-pin FLAT)

## APPLICATION

- Reset pulse generation for almost all logic circuits
- Battery checking, level detecting, waveform shaping circuits
- Delayed waveform generating circuit
- Switching circuit to a back-up power supply
- DC/DC converter
- Over voltage protection circuit

## RECOMMENDED OPERATING CONDITION

- Supply voltage range ..... 2V to 7V

## PIN CONFIGURATION (TOP VIEW)

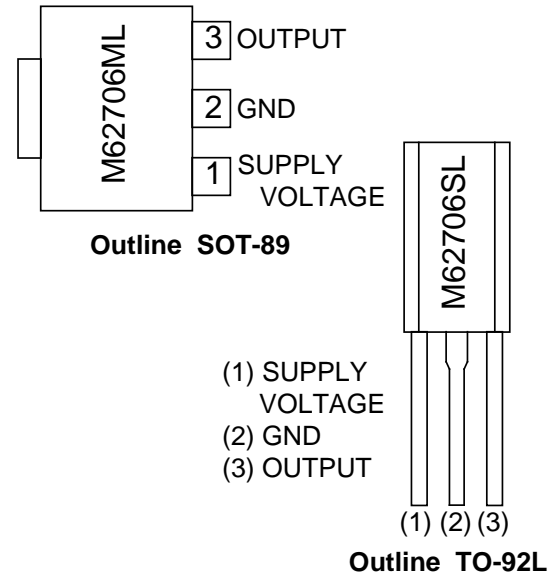

## BLOCK DIAGRAM

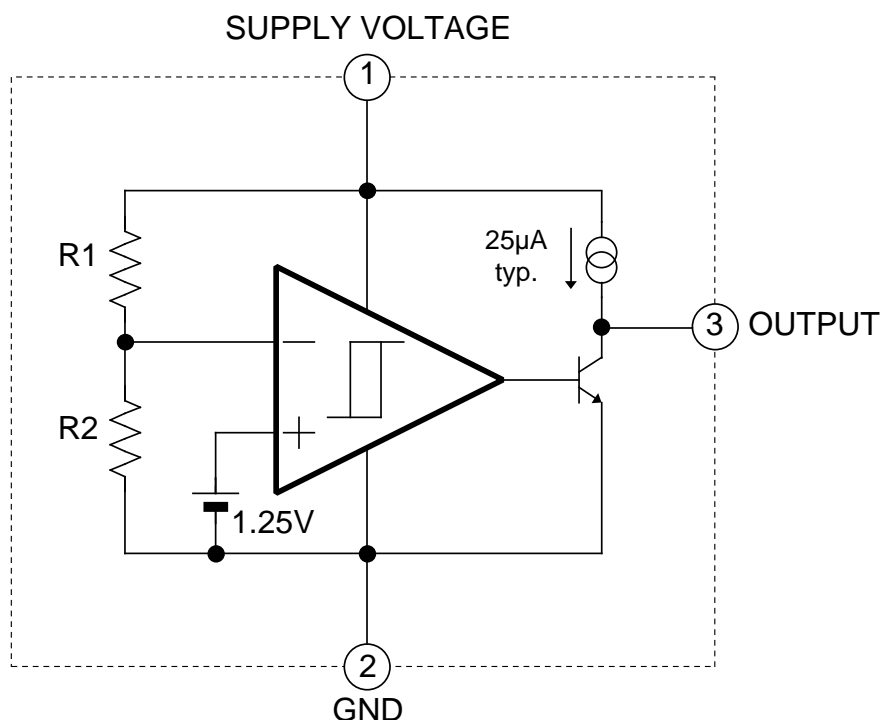

**PRELIMINARY**  
 Notice: This is not a final specification.  
 Some parametric limits are subject to change.

MITSUBISHI Dig./Ana.INTERFACE

# M62706ML,SL

VOLTAGE DETECTING, SYSTEM RESETTING IC SERIES

## FUNCTION DIAGRAM

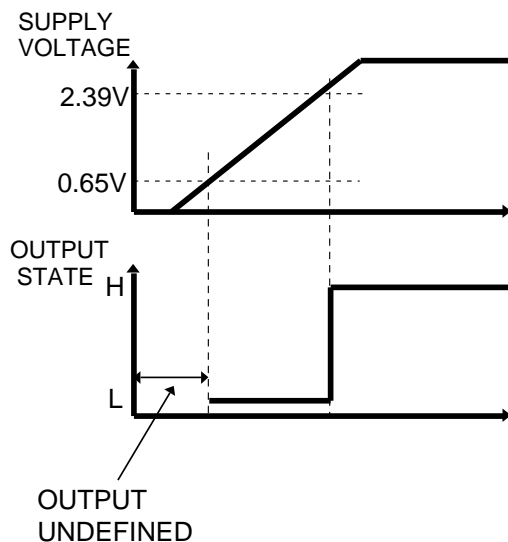

## ABSOLUTE MAXIMUM RATINGS (Ta=25°C, Unless otherwise noted)

Symbol	Parameter	Test condition		Ratings	Unit
I <sub>cc</sub>	Supply Voltage			7	V
I <sub>sink</sub>	Output Sink Current			6	mA
V <sub>o</sub>	Output Voltage	Output with constant current load		V <sub>cc</sub>	V
P <sub>d</sub>	Power Dissipation	3pin SIL		700	mW
		3pin FLAT		500	
K <sub>θ</sub>	Thermal Derating	Ta 25°C	3PIN SIL	7	mW/°C
			3PIN FLAT	5	
T <sub>opr</sub>	Operating Temperature			-30 to +85	°C
T <sub>stg</sub>	Storage Temperature			-40 to +125	°C

## ELECTRICAL CHARACTERISTICS (Ta=25°C, Unless otherwise noted)

Symbol	Parameter	Test condition	Limits			Unit	
			MIN	TYP	MAX		
V <sub>s</sub>	Detecting Voltage		2.28	2.39	2.50	V	
V <sub>s</sub>	Hysteresis Voltage		50	80	110	mV	
V <sub>s</sub> / T	Detecting Voltage Temperature Coefficient		—	0.01	—	%/°C	
I <sub>cc</sub>	Circuit Current	V <sub>cc</sub> =2.7V	—	210	340	μA	
V <sub>sat</sub>	Output Saturation Voltage	V <sub>cc</sub> =2V, I <sub>sink</sub> =4mA	—	0.2	0.4	V	
V <sub>oPL</sub>	Threshold Operating Voltage	Minimum supply voltage for IC operation	R <sub>L</sub> =2.2k, V <sub>sat</sub> 0.4V	—	0.7	0.8	V
			R <sub>L</sub> =100k, V <sub>sat</sub> 0.4V	—	0.6	0.7	
I <sub>oc</sub>	Output Load Current	V <sub>cc</sub> =2V, V <sub>o</sub> =1/2V <sub>cc</sub>	-40	-25	-17	μA	
V <sub>OH</sub>	Output HIGH Voltage		V <sub>cc</sub> -0.2	V <sub>cc</sub> -0.06		V	
t <sub>PHL</sub>	Propagation Delay Time	Response time when V <sub>cc</sub> changes H to L	—	6	—	μs	
t <sub>PLH</sub>		Response time when V <sub>cc</sub> changes L to H	—	3	—		

**PRELIMINARY**  
Notice: This is not a final specification.  
Some parametric limits are subject to change.

MITSUBISHI Dig./Ana.INTERFACE

# M62706ML,SL

VOLTAGE DETECTING, SYSTEM RESETTIC IC SERIES

## Example of application circuit Reset Circuit of M627XX Series

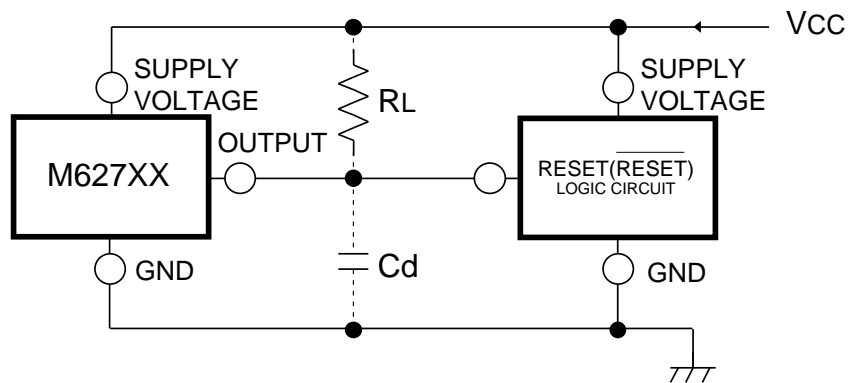

Note 1.

This IC can be used whether or not a pull-up resistor is included in the logic circuit.

Note 2.

The logic circuit preferably should not have a pull-down resistor. However in the case it has the resistor, the load resistor RL must be much less than the pull-down resistor. (refer to the above application circuit)

⚠ Mitsubishi Electric Corporation puts the maximum effort into making semiconductor products better and more reliable, but there is always the possibility that trouble may occur with them. Trouble with semiconductors may lead to personal injury, fire or property damage. Remember to give due consideration to safety when making your circuit design, in order to prevent fires from spreading, redundancy, malfunction or other mishap.