



AML3400

High Definition Total Solution

The **AML3400** HD A/V processor is a completely integrated system targeting all types of high definition Audio/Video processing applications. The AML3400 combines full function of MPEG-2 and HVD decoding, numerous dedicated and general-purpose peripherals, and an embedded 32-bit host CPU in a single device. The AML3400 has two high speed AMRISC™ 24-bit RISC processors with special instructions to accommodate audio and HD video digital signal processing.

The embedded 32-bits host CPU handles system initialization, DVD navigation and other system applications. The AML3400 A/V processor provides a glueless interface to all external components: ATAPI loaders, Thomson serial front-end devices, audio DACs and memory. Numerous general-purpose I/O pins can be used to control the front panel display and other miscellaneous tasks. The Flash interface allows the Flash memory to be shared with the front-end chip to reduce system cost in mono-board designs. Together, the embedded host CPU and special glueless interfaces reduce the total system cost for high definition A/V applications.

The AML3400 HD A/V processor is equipped with an NTSC/PAL TV encoder, picture-in-picture (PIP), and picture in graphics (PIG) capability. It supports S-Video, composite, YUV component and RGB. The video encoder also supports high-quality de-interlaced progressive scan (480p/576p) with full Macrovision support. Contrast enhancement, hue adjustment, video scaling, video interpolation, pan-scan, letter-box, and zoom are also supported. The AML3400 supports High Definition Output (720p/1080i/1080p) and supports simultaneous output of progressive (480p) and interlaced (480i) video. In addition, built in Video DACs complement the video encoder further reducing system cost.

The integrated AMRISC™ RISC processor is designed to support advanced digital audio processing. The micro-coded engine provides support for all existing audio formats and it also has enough flexibility and headroom to accommodate future audio standards. Popular audio formats like Dolby AC-3 5.1, DTS, HDCD, MP-3 and WMA are supported. The AML3400 also has an IEC958 digital input to accommodate DVD A/V Receiver applications.



Amlogic Inc.
www.amlogic.com

Room 901-906, Pine City, 777 Zhao Jia Bang Road, Shanghai 200032, P.R.China
Tel:86-21-64436919,64436920,64435125 Fax:86-21-64431158

Room 1201, High-Tech Plaza Tower A, Tianan Cyber Park, Shenzhen 518040, P.R.China
Tel:86-775-83433516,83433526,83433536 Fax:86-755-83433163

3970 Freedom Circle, Santa Clara, CA 95054, U.S.A
Tel:001-408-9700888 Fax:001-408-9700888

AML3400 High Definition Total Solution

DVD/HVD Decoding

- HVD Standard compliant
- MPEG-2 ML/MP conforming to ISO-13818
- MPEG-1 ML/MP conforming to ISO-11172
- On-Chip CSS descrambler
- Compliant with DVD Specification 1.0 for ready-only Disc decoding
- Advanced error detection, concealment, and recovery scheme
- Backward compatible VCD (1.0 - 2.0) decoding
- Super VCD decoding
- High speed AMRISC™ 24-bit RISC CPU with special instruction extensions designed specifically for MPEG and HVD decoding

Built-in TV encoder

- Six 10-bit video DACs
- Real-time interlaced NTSC output 720x480 at 30fps and PAL 720x576 at 25fps Macrovision 7.1L1 anti-taping process
- NTSC Progressive output (480p) at 60fps, PAL Progressive (576p) at 50fps Macrovision 1.03 anti-taping process
- Interlaced, S-Video, component, composite and SCART output
- Closed caption
- Simultaneous output of Progressive and Interlaced video
- Progressive RGB and VGA output

Built-in Host CPU

- 32-bit CPU dedicated for user applications
- Embedded debug interface using ICE/JTAG
- Able to utilize MPEG SDRAM as run time data storage for minimal system cost
- Configurable for 16-bit wide SDRAM
- Supports 8 or 16-bit EPROM or Flash
- The Flash can be shared with Front-End chips

Video

- Full MPEG-2 main profile @ main level 4.2.0 video decoding
- On-Screen-Display (OSD) capable of supporting up to 256 colors
- OSD Alpha-blending over video display
- Video Zoom in for visual effects
- Built-in full screen NTSC to PAL scaling or vice-versa
- Built-in logic and data channel for Picture-in-Picture (PIP) and Picture-in-Graphic (PIG) or vice-versa
- Built-in contrast enhancement, hue adjustment, and flesh tone correction features
- Built-in hardware for video interpolation and decimation
- Supports maximum zoom ratio up to 8x
- OSD is 16 color programmable

Audio

- Built-in AMRISC™ 24-bit RISC CPU with extensions specifically designed for Audio Processing
- Compliant with Dolby AC-3 5.1 channel decoding
- AC-3 two channel downmixing
- IEC958 output (S/PDIF)
- Full MPEG audio layers I, II and III (MP3)
- Supports 8 channel linear PCM output
- DTS, HDCD, WMA and DVD-Audio
- IEC958 digital input with frame decoding to accommodate A/V Receiver applications

Graphics

- Anti-flicker hardware for interlaced video
- Supports high speed clock move for panning
- Built-in 2D graphics accelerator
- Dedicated graphics display controller separate from MPEG engine for optimal video overlay performance
- High Resolution graphics ARC processor and memory
- Supports NTSC and PAL graphics modes with maximum 64k color
- Video overlay with graphics and vice-versa
- Built-in graphics conversion unit for 16-bit RGB graphics (C5-6-5) data conversion to CCIR601 YcbCr 4:2:2 TV encoder output format
- Unified MPEG and graphics memory architecture for maximum flexibility and system cost savings

Peripherals and Interface

- Supports glueless interface to DVD DSP, CD DSP, and DVD-ROM devices
- Direct connection to Audio DACs using 12S
- 14+ General Purpose I/O pins
- IDE with DMA transfer supporting up to 2 IDE devices such as ATAPI DVD-ROM or hard drive
- Philips Bufferless ATAPI interface
- Thomson Multimedia Serial Interface
- Smart Media interface/Compact Flash/SD
- NEC Encoder interface uPD61051
- Philips Encoder interface SAA6752HS

Miscellaneous

- 208-pin PQFP/128-pin PQFP
- 1.8V operating voltage, 5V tolerant inputs, 3.3V outputs

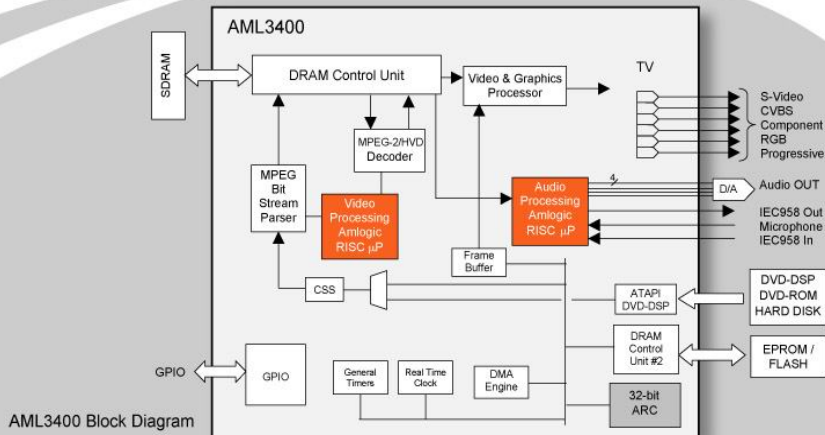

AML3400 Block Diagram

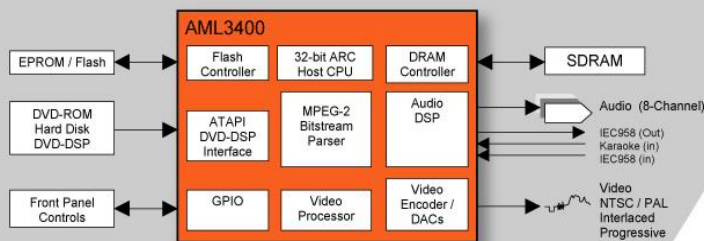

DVD System Diagram