

MITSUBISHI LSIs
M6MGB/T162S4BVP
 16,777,216-BIT (1,048,576 -WORD BY 16-BIT) CMOS
 3.3V-ONLY FLASH MEMORY &
 4,194,304-BIT (524,288-WORD BY 8-BIT) CMOS SRAM
 Stacked-MCP (Multi Chip Package)

DESCRIPTION

The MITSUBISHI M6MGB/T162S4BVP is a Stacked Multi Chip Package (S-MCP) that contents 16M-bits flash memory and 4M-bits Static RAM in a 48-pin TSOP (TYPE-I).

16M-bits Flash memory is a 1048576 words, 3.3V-only, and high performance non-volatile memory fabricated by CMOS technology for the peripheral circuit and DINOR(DIvided bit-line NOR) architecture for the memory cell.
 4M-bits SRAM is a 262144words unsynchronous SRAM fabricated by silicon-gate CMOS technology.

M6MGB/T162S4BVP is suitable for the application of the mobile-communication-system to reduce both the mount space and weight .

FEATURES

- Access time

Flash Memory	90ns (Max.)
SRAM	85ns (Max.)
- Supply voltage

	Vcc=2.7 ~ 3.6V
--	----------------
- Ambient temperature

W version	Ta=-20 ~ 85°C
-----------	---------------
- Package : 48-pin TSOP (Type-I) , 0.4mm lead pitch

APPLICATION

Mobile communication products

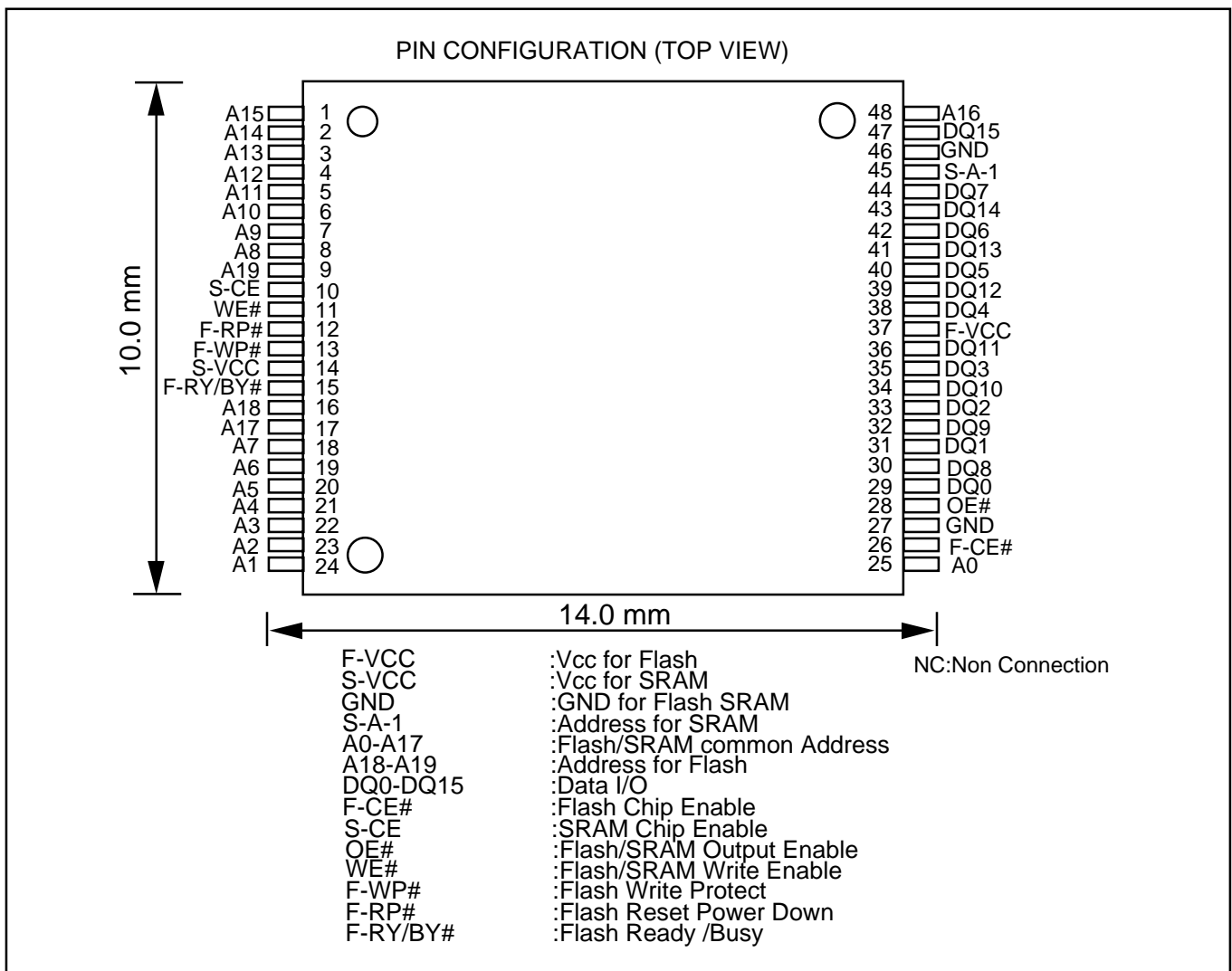

MITSUBISHI LSIs
M6MGB/T162S4BVP
 16,777,216-BIT (1,048,576-WORD BY 16-BIT) CMOS
 3.3V-ONLY FLASH MEMORY &
 4,194,304-BIT (524,288-WORD BY 8-BIT) CMOS SRAM
 Stacked-MCP (Multi Chip Package)

BLOCK DIAGRAM

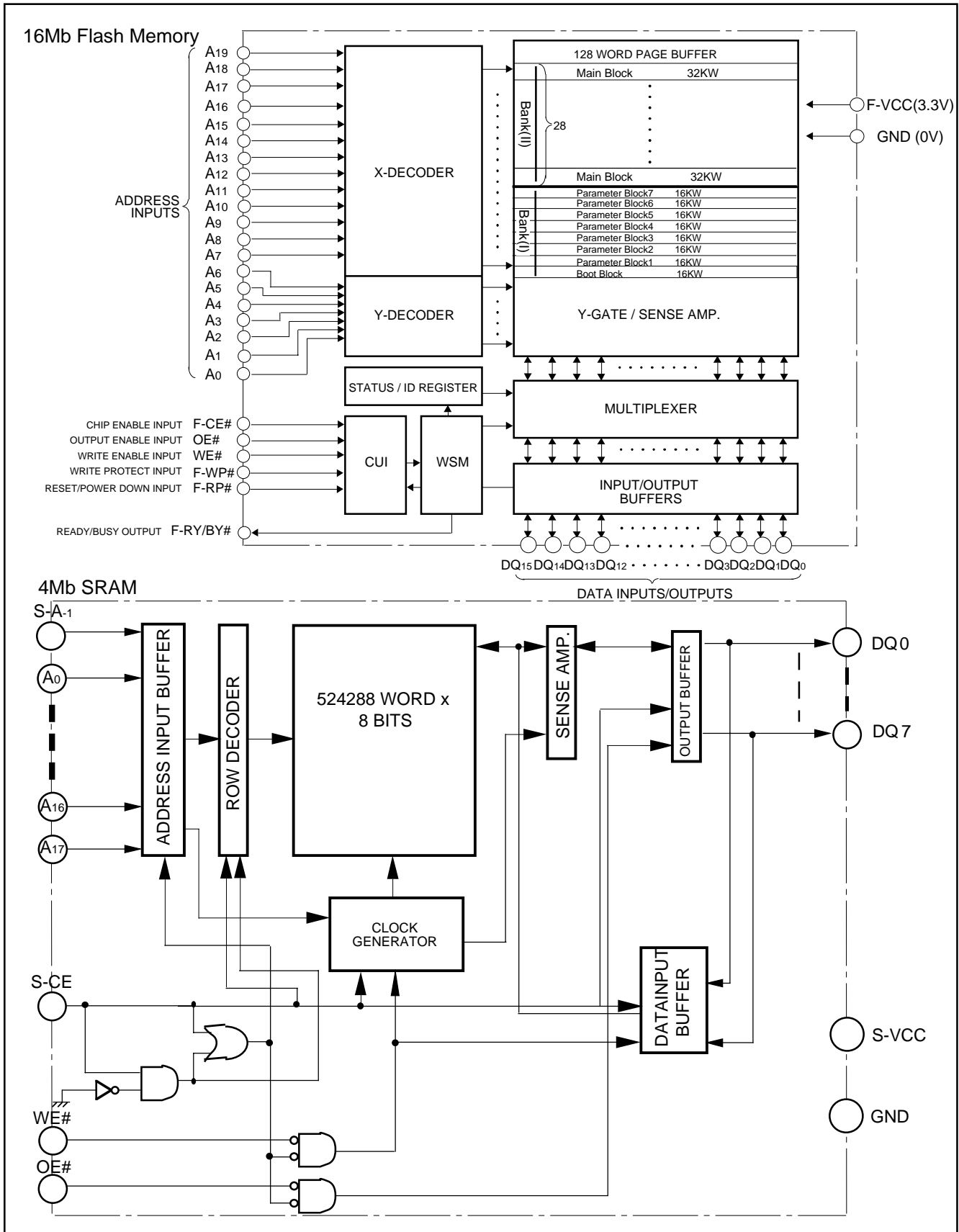

1. Flash Memory

DESCRIPTION

The Flash Memory of M6MGB/T162S4BVP is 3.3V-only high speed 16,777,216-bit CMOS boot block Flash Memories with alternating BGO (Back Ground Operation) feature. The BGO feature of the device allows Program or Erase operations to be performed in one bank while the device simultaneously allows Read operations to be performed on the other bank. This BGO feature is suitable for mobile and personal computing, and communication products. The Flash Memory of M6MGB/T162S4BVP is fabricated by CMOS technology for the peripheral circuits and DINOR(Divided bit line NOR) architecture for the memory cells.

FEATURES

- Organization1048,576 word x 16bit
- Supply voltage Vcc = 2.7~3.6V
- Access time 90ns (Max.)
- Power Dissipation
 - Read 54 mW (Max. at 5MHz)
 - (After Automatic Power saving) 0.33 μ W (typ.)
 - Program/Erase126 mW (Max.)
 - Standby 0.33 μ W (typ.)
 - Deep power down mode 0.33 μ W (typ.)
- Auto program for Bank(I)
 - Program Time4ms (typ.)
 - Program Unit
 - (Byte Program)1word
 - (Page Program) 128word
- Auto program for Bank(II)
 - Program Time4ms (typ.)
 - Program Unit 128word
- Auto Erase
 - Erase time 40 ms (typ.)
 - Erase Unit
 - Bank(I) Boot Block 16Kword x 1
 - Parameter Block 16Kword x 7
 - Bank(II) Main Block 32Kword x 28
- Program/Erase cycles100Kcycles
- Boot Block
 - M6MGB162S4BVP Bottom Boot
 - M6MGT162S4BVP Top Boot
- Other Functions
 - Soft Ware Command Control
 - Selective Block Lock
 - Erase Suspend/Resume
 - Program Suspend/Resume
 - Status Register Read
 - Alternating Back Ground Program/Erase Operation
Between Bank(I) and Bank(II)

FUNCTION

The Flash Memory of M6MGB/T162S4BVP includes on-chip program/erase control circuitry. The Write State Machine (WSM) controls block erase and byte/page program operations. Operational modes are selected by the commands written to the Command User Interface (CUI). The Status Register indicates the status of the WSM and when the WSM successfully completes the desired program or block erase operation.

A Deep Powerdown mode is enabled when the F-RP# pin is at GND, minimizing power consumption.

Read

The Flash Memory of M6MGB/T162S4BVP has three read modes, which accesses to the memory array, the Device Identifier and the Status Register. The appropriate read command are required to be written to the CUI. Upon initial device powerup or after exit from deep powerdown, the Flash Memory automatically resets to read array mode. In the read array mode, low level input to F-CE# and OE#, high level input to WE# and F-RP#, and address signals to the address inputs (A19-A0:Word Mode) output the data of the addressed location to the data input/output (D15-D0:Word Mode).

Write

Writes to the CUI enables reading of memory array data, device identifiers and reading and clearing of the Status Register. They also enable block erase and program. The CUI is written by bringing WE# to low level, while F-CE# is at low level and OE# is at high level. Address and data are latched on the earlier rising edge of WE# and F-CE#. Standard micro-processor write timings are used.

Alternating Background Operation (BGO)

The Flash Memory of M6MGB/T162S4BVP allows to read array from one bank while the other bank operates in software command write cycling or the erasing / programming operation in the background. Read array operation with the other bank in BGO is performed by changing the bank address without any additional command. When the bank address points the bank in software command write cycling or the erasing / programming operation, the data is read out from the status register. The access time with BGO is the same as the normal read operation.

Output Disable

When OE# is at VIH, output from the devices is disabled. Data input/output are in a high-impedance(High-Z) state.

Standby

When F-CE# is at VIH, the device is in the standby mode and its power consumption is reduced. Data input/output are in a high-impedance(High-Z) state. If the memory is deselected during block erase or program, the internal control circuits remain active and the device consume normal active power until the operation completes.

Deep Power-Down

When F-RP# is at VIL, the device is in the deep powerdown mode and its power consumption is substantially low. During read modes, the memory is deselected and the data input/output are in a high-impedance(High-Z) state. After return from powerdown, the CUI is reset to Read Array , and the Status Register is cleared to value 80H.

During block erase or program modes, F-RP# low will abort either operation. Memory array data of the block being altered become invalid.

Automatic Power-Saving (APS)

The Automatic Power-Saving minimizes the power consumption during read mode. The device automatically turns to this mode when any addresses or F-CE# isn't changed more than 200ns after the last alternation. The power consumption becomes the same as the stand-by mode. While in this mode, the output data is latched and can be read out. New data is read out correctly when addresses are changed.

SOFTWARE COMMAND DEFINITIONS

The device operations are selected by writing specific software command into the Command User Interface.

Read Array Command (FFH)

The device is in Read Array mode on initial device power up and after exit from deep powerdown, or by writing FFH to the Command User Interface. After starting the internal operation the device is set to the read status register mode automatically.

Read Device Identifier Command (90H)

It can normally read device identifier codes when Read Device Identifier Code Command(90H) is written to the command latch. Following the command write, the manufacturer code and the device code can be read from address 0000H and 0001H, respectively.

Read Status Register Command (70H)

The Status Register is read after writing the Read Status Register command of 70H to the Command User Interface. Also, after starting the internal operation the device is set to the Read Status Register mode automatically.

The contents of Status Register are latched on the later falling edge of OE# or F-CE#. So F-CE# or OE# must be toggled every status read.

Clear Status Register Command (50H)

The Erase Status, Program Status and Block Status bits are set to "1"s by the Write State Machine and can only be reset by the Clear Status Register command of 50H. These bits indicates various failure conditions.

Block Erase / Confirm Command (20H/D0H)

Automated block erase is initiated by writing the Block Erase command of 20H followed by the Confirm command of D0H. An address within the block to be erased is required. The WSM executes iterative erase pulse application and erase verify operation.

Program Commands

A)Word/Byte Program (40H)

Word program is executed by a two-command sequence. The Word Program Setup command of 40H is written to the Command Interface, followed by a second write specifying the address and data to be written. The WSM controls the program pulse application and verify operation. The Word Program Command is Valid for only Bank(I).

B)Page Program for Data Blocks (41H)

Page Program for Bank(I) and Bank(II) allows fast programming of 128words/256bytes of data. Writing of 41H initiates the page program operation for the Data area. From 2nd cycle to 129th cycle, write data must be serially inputted. Address A6-A0 have to be incremented from 00H to 7FH. After completion of data loading, the WSM controls the program pulse application and verify operation.

C)Single Data Load to Page Buffer (74H) / Page Buffer to Flash (0EH/D0H)

Single data load to the page buffer is performed by writing 74H followed by a second write specifying the column address and data. Distinct data up to 128word can be loaded to the page buffer by this two-command sequence. On the other hand, all of the loaded data to the page buffer is programmed simultaneously by writing Page Buffer to Flash command of 0EH followed by the confirm command of D0H. After completion of programming the data on the page buffer is cleared automatically.

This command is valid for only Bank(I) alike Word Program.

Clear Page Buffer Command (55H)

Loaded data to the page buffer is cleared by writing the Clear Page Buffer command of 55H followed by the Confirm command of D0H. This command is valid for clearing data loaded by Single Data Load to Page Buffer command.

Suspend/Resume Command (B0H/D0H)

Writing the Suspend command of B0H during block erase operation interrupts the block erase operation and allows read out from another block of memory. Writing the Suspend command of B0H during program operation interrupts the program operation and allows read out from another block of memory. The Bank address is required when writing the Suspend/Resume Command. The device continues to output Status Register data when read, after the Suspend command is written to it. Polling the WSM Status and Suspend Status bits will determine when the erase operation or program operation has been suspended. At this point, writing of the Read Array command to the CUI enables reading data from blocks other than that which is suspended. When the Resume command of D0H is written to the CUI, the WSM will continue with the erase or program processes.

DATA PROTECTION

The Flash Memory of M6MGB/T162S4BVP provides selectable block locking of memory blocks. Each block has an associated nonvolatile lock-bit which determines the lock status of the block. In addition, the Flash Memory has a master Write Protect pin (F-WP#) which prevents any modifications to memory blocks whose lock-bits are set to "0", when F-WP# is low. When F-WP# is high, all blocks can be programmed or erased regardless of the state of the lock-bits, and the lock-bits are cleared to "1" by erase. See the BLOCK LOCKING table on P.9 for details.

Power Supply Voltage

When the power supply voltage (F-VCC) is less than V_{LKO} , Low Vcc Lock-Out voltage, the device is set to the Read-only mode. Regarding DC electrical characteristics of V_{LKO} , see P.10.

A delay time of 2 us is required before any device operation is initiated. The delay time is measured from the time F-Vcc reaches F-Vccmin (2.7V).

During power up, F-RP#=GND is recommended. Falling in Busy status is not recommended for possibility of damaging the device.

MEMORY ORGANIZATION

The Flash Memory of M6MGB/T162S4BVP has one 16Kword boot block, seven 16Kword parameter blocks, for Bank(I) and twenty-eight 32Kword main blocks for Bank(II). A block is erased independently of other blocks in the array.

MITSUBISHI LSIs
M6MGB/T162S4BVP
16,777,216-BIT (1,048,576 -WORD BY 16-BIT) CMOS
3.3V-ONLY FLASH MEMORY &
4,194,304-BIT (524,288-WORD BY 8-BIT) CMOS SRAM
Stacked-MCP (Multi Chip Package)

MEMORY ORGANIZATION

x16 (Wordmode)

F8000H-FFFFFH	32Kword MAIN BLOCK 35
F0000H-F7FFFH	32Kword MAIN BLOCK 34
E8000H-EFFFFH	32Kword MAIN BLOCK 33
E0000H-E7FFFH	32Kword MAIN BLOCK 32
D8000H-DFFFFH	32Kword MAIN BLOCK 31
D0000H-D7FFFH	32Kword MAIN BLOCK 30
C8000H-CFFFFH	32Kword MAIN BLOCK 29
C0000H-C7FFFH	32Kword MAIN BLOCK 28
B8000H-BFFFFH	32Kword MAIN BLOCK 27
B0000H-B7FFFH	32Kword MAIN BLOCK 26
A8000H-AFFFFH	32Kword MAIN BLOCK 25
A0000H-A7FFFH	32Kword MAIN BLOCK 24
98000H-9FFFFH	32Kword MAIN BLOCK 23
90000H-97FFFH	32Kword MAIN BLOCK 22
88000H-8FFFFH	32Kword MAIN BLOCK 21
80000H-87FFFH	32Kword MAIN BLOCK 20
78000H-7FFFFH	32Kword MAIN BLOCK 19
70000H-77FFFH	32Kword MAIN BLOCK 18
68000H-6FFFFH	32Kword MAIN BLOCK 17
60000H-67FFFH	32Kword MAIN BLOCK 16
58000H-5FFFFH	32Kword MAIN BLOCK 15
50000H-57FFFH	32Kword MAIN BLOCK 14
48000H-4FFFFH	32Kword MAIN BLOCK 13
40000H-47FFFH	32Kword MAIN BLOCK 12
38000H-3FFFFH	32Kword MAIN BLOCK 11
30000H-37FFFH	32Kword MAIN BLOCK 10
28000H-2FFFFH	32Kword MAIN BLOCK 9
20000H-27FFFH	32Kword MAIN BLOCK 8
1C000H-1FFFFH	16Kword PARAMETER BLOCK 7
18000H-1BFFFH	16Kword PARAMETER BLOCK 6
14000H-17FFFH	16Kword PARAMETER BLOCK 5
10000H-13FFFH	16Kword PARAMETER BLOCK 4
0C000H-0FFFFH	16Kword PARAMETER BLOCK 3
08000H-0BFFFH	16Kword PARAMETER BLOCK 2
04000H-07FFFH	16Kword PARAMETER BLOCK 1
00000H-03FFFH	16Kword BOOT BLOCK 0

A₁₉-A₀
(Word Mode)

**Flash Memory of M6MGB162S4BVP
Memory Map**

x16 (Wordmode)

FC000H-FFFFFH	16Kword BOOT BLOCK 35
F8000H-FBFFFH	16Kword PARAMETER BLOCK 34
F4000H-F7FFFH	16Kword PARAMETER BLOCK 33
F0000H-F3FFFH	16Kword PARAMETER BLOCK 32
EC000H-EFFFFH	16Kword PARAMETER BLOCK 31
E8000H-EBFFFH	16Kword PARAMETER BLOCK 30
E4000H-E7FFFH	16Kword PARAMETER BLOCK 29
E0000H-E3FFFH	16Kword PARAMETER BLOCK 28
D8000H-DFFFFH	32Kword MAIN BLOCK 27
D0000H-D7FFFH	32Kword MAIN BLOCK 26
C8000H-CFFFFH	32Kword MAIN BLOCK 25
C0000H-C7FFFH	32Kword MAIN BLOCK 24
B8000H-BFFFFH	32Kword MAIN BLOCK 23
B0000H-B7FFFH	32Kword MAIN BLOCK 22
A8000H-AFFFFH	32Kword MAIN BLOCK 21
A0000H-A7FFFH	32Kword MAIN BLOCK 20
98000H-9FFFFH	32Kword MAIN BLOCK 19
90000H-97FFFH	32Kword MAIN BLOCK 18
88000H-8FFFFH	32Kword MAIN BLOCK 17
80000H-87FFFH	32Kword MAIN BLOCK 16
78000H-7FFFFH	32Kword MAIN BLOCK 15
70000H-77FFFH	32Kword MAIN BLOCK 14
68000H-6FFFFH	32Kword MAIN BLOCK 13
60000H-67FFFH	32Kword MAIN BLOCK 12
58000H-5FFFFH	32Kword MAIN BLOCK 11
50000H-57FFFH	32Kword MAIN BLOCK 10
48000H-4FFFFH	32Kword MAIN BLOCK 9
40000H-47FFFH	32Kword MAIN BLOCK 8
38000H-3FFFFH	32Kword MAIN BLOCK 7
30000H-37FFFH	32Kword MAIN BLOCK 6
28000H-2FFFFH	32Kword MAIN BLOCK 5
20000H-27FFFH	32Kword MAIN BLOCK 4
18000H-1FFFFH	32Kword MAIN BLOCK 3
10000H-17FFFH	32Kword MAIN BLOCK 2
08000H-0FFFFH	32Kword MAIN BLOCK 1
00000H-07FFFH	32Kword MAIN BLOCK 0

A₁₉-A₀
(Word Mode)

**Flash Memory of M6MGT162S4BVP
Memory Map**

MITSUBISHI LSIs
M6MGB/T162S4BVP
 16,777,216-BIT (1,048,576 -WORD BY 16-BIT) CMOS
 3.3V-ONLY FLASH MEMORY &
 4,194,304-BIT (524,288-WORD BY 8-BIT) CMOS SRAM
 Stacked-MCP (Multi Chip Package)

BUS OPERATIONS

Bus Operations for Word-Wide Mode

Mode \ Pins		F-CE#	OE#	WE#	F-RP#	DQ0-15	F-RY/BY#
Read	Array	V _{IL}	V _{IL}	V _{IH}	V _{IH}	Data out	VOH (Hi-Z)
	Status Register	V _{IL}	V _{IL}	V _{IH}	V _{IH}	Status Register Data	X ¹⁾
	Lock Bit Status	V _{IL}	V _{IL}	V _{IH}	V _{IH}	Lock Bit Data (DQ6)	X
	Identifier Code	V _{IL}	V _{IL}	V _{IH}	V _{IH}	Identifier Code	VOH (Hi-Z)
Output disable		V _{IL}	V _{IH}	V _{IH}	V _{IH}	Hi-Z	X
Stand by		V _{IH}	X ²⁾	X	V _{IH}	Hi-Z	X
Write	Program	V _{IL}	V _{IH}	V _{IL}	V _{IH}	Command/Data in	X
	Erase	V _{IL}	V _{IH}	V _{IL}	V _{IH}	Command	X
	Others	V _{IL}	V _{IH}	V _{IL}	V _{IH}	Command	X
Deep Power Down		X	X	X	V _{IL}	Hi-Z	VOH (Hi-Z)

1) X at F-RY/BY# is VOL or VOH(Hi-Z).

*The F-RY/BY# is an open drain output pin and indicates status of the internal WSM. When low, it indicates that the WSM is Busy performing an operation. A pull-up resistor of 10K-100K Ohms is required to allow the F-RY/BY# signal to transition high indicating a Ready WSM condition.

2) X can be V_{IH} or V_{IL} for control pins.

MITSUBISHI LSIs
M6MGB/T162S4BVP
16,777,216-BIT (1,048,576 -WORD BY 16-BIT) CMOS
3.3V-ONLY FLASH MEMORY &
4,194,304-BIT (524,288-WORD BY 8-BIT) CMOS SRAM
Stacked-MCP (Multi Chip Package)

SOFTWARE COMMAND DEFINITION

Command List

Command	1st bus cycle			2nd bus cycle			3rd ~129th bus cycles (Word Mode)		
	Mode	Address	Data (DQ15-0)	Mode	Address	Data (DQ15-0)	Mode	Address	Data (DQ15-0)
Read Array	Write	X	FFH						
Device Identifier	Write	X	90H	Read	IA ²⁾	ID ²⁾			
Read Status Register	Write	Bank ³⁾	70H	Read	Bank	SRD ⁴⁾			
Clear Status Register	Write	X	50H						
Clear Page Buffer	Write	X	55H	Write	X	D0H ¹⁾			
Word Program ⁵⁾	Write	Bank(I) ⁵⁾	40H	Write	WA ⁶⁾	WD ⁶⁾			
Page Program ⁷⁾	Write	Bank	41H	Write	WA0 ⁷⁾	WD0 ⁷⁾	Write	WAn ⁷⁾	WDn ⁷⁾
Single Data Load to Page Buffer ⁵⁾	Write	Bank(I) ⁵⁾	74H	Write	WA	WD			
Page Buffer to Flash ⁵⁾	Write	Bank(I) ⁵⁾	0EH	Write	WA ⁸⁾	D0H ¹⁾			
Block Erase / Confirm	Write	Bank	20H	Write	BA ⁹⁾	D0H ¹⁾			
Suspend	Write	Bank	B0H						
Resume	Write	Bank	D0H						
Read Lock Bit Status	Write	X	71H	Read	BA	DQ6 ¹⁰⁾			
Lock Bit Program / Confirm	Write	Bank	77H	Write	BA	D0H ¹⁾			
Erase All Unlocked Blocks	Write	X	A7H	Write	X	D0H ¹⁾			

1) In the word-wide version, upper byte data (DQ8-DQ15) is ignored.

2) IA=ID Code Address : A0=VIL (Manufacturer's Code) : A0=VIH (Device Code), ID=ID Code

3) Bank = Bank Address (Bank(I) or Bank(II)) : A19-A17.

4) SRD = Status Register Data

5) Word Program, Single Data Load and Page Buffer to Flash Command is valid for only Bank(I).

6) WA = Write Address, WD = Write Data

7) WA0,WAn=Write Address, WD0,WDn=Write Data.

Write Address and Write Data must be provided sequentially from 00H to 7FH for A6-A0. Page size is 128word (128word x 16bit).
and also A19-A7(Block Address, Page Address) must be valid.

8) WA = Write Address : Upper page address, A19-A7(Block Address, Page Address) must be valid.

9) BA = Block Address : BA = Block Address : A19-A14(Bank1) A19-A15(Bank2)

10) DQ6 provides Block Lock Status, DQ6 = 1 : Block Unlock, DQ6 = 0 : Block Locked.

BLOCK LOCKING

F-RP#	F-WP#	Lock Bit (Internally)	Write Protection Provided				Note
			BANK(I)		BANK(II)	Lock Bit	
			Boot	Parameter	Data		
V _{IL}	X	X	Locked	Locked	Locked	Locked	Deep Power Down Mode
V _{IH}	V _{IL}	0	Locked	Locked	Locked	Locked	
		1	Locked	Unlocked	Unlocked	Locked	
	V _{IH}	X	Unlocked	Unlocked	Unlocked	Unlocked	All Blocks Unlocked

1) DQ6 provides Lock Status of each block after writing the Read Lock Status command (71H).

WP# pins must not be switched during performing Erase / Write operations or WSM Busy (WSMS = 0).

2) Erase/Write command for locked blocks is aborted. At this time read mode is not array read mode but status read mode and 00B0H is read. Please issue Clear Status Register command plus Read Array command to change the mode from status read mode to array read mode.

STATUS REGISTER

Symbol	Status	Definition	
		"1"	"0"
SR.7 (DQ7)	Write State Machine Status	Ready	Busy
SR.6 (DQ6)	Suspend Status	Suspended	Operation in Progress / Completed
SR.5 (DQ5)	Erase Status	Error	Successful
SR.4 (DQ4)	Program Status	Error	Successful
SR.3 (DQ3)	Block Status after Program	Error	Successful
SR.2 (DQ2)	<i>Reserved</i>	-	-
SR.1 (DQ1)	<i>Reserved</i>	-	-
SR.0 (DQ0)	<i>Reserved</i>	-	-

*The F-RY/BY# is an open drain output pin and indicates status of the internal WSM. When low, it indicates that the WSM is Busy performing an operation. A pull-up resistor of 10K-100K Ohms is required to allow the F-RY/BY# signal to transition high indicating a Ready WSM condition.

*DQ3 indicates the block status after the page programming, word programming and page buffer to flash. When DQ3 is "1", the page has the over-programmed cell. If over-program occurs, the device is block fail. However if DQ3 is "1", please try the block erase to the block. The block may revive.

MITSUBISHI LSIs
M6MGB/T162S4BVP
 16,777,216-BIT (1,048,576 -WORD BY 16-BIT) CMOS
 3.3V-ONLY FLASH MEMORY &
 4,194,304-BIT (524,288-WORD BY 8-BIT) CMOS SRAM
 Stacked-MCP (Multi Chip Package)

DEVICE IDENTIFIER CODE

Code \ Pins	A ₀	DQ ₇	DQ ₆	DQ ₅	DQ ₄	DQ ₃	DQ ₂	DQ ₁	DQ ₀	Hex. Data
Manufacturer Code	V _{IL}	0	0	0	1	1	1	0	0	1CH
Device Code (-T162S4BVP)	V _{IH}	1	0	1	0	0	0	0	0	A0H
Device Code (-B162S4BVP)	V _{IH}	1	0	1	0	0	0	0	1	A1H

The upper data(D₁₅₋₈) is "0".

ABSOLUTE MAXIMUM RATINGS

Symbol	Parameter	Conditions	Min	Max	Unit
F-V _{CC}	Flash V _{CC} voltage	With respect to Ground	-0.2	4.6	V
V _{I1}	All input or output voltage ¹⁾		-0.6	4.6	V
T _a	Ambient temperature		-20	85	°C
T _{bs}	Temperature under bias		-50	95	°C
T _{stg}	Storage temperature		-65	125	°C
I _{OUT}	Output short circuit current			100	mA

1) Minimum DC voltage is -0.5V on input/output pins. During transitions, this level may undershoot to -2.0V for periods <20ns. Maximum DC voltage on input/output pins is F-V_{CC}+0.5V which, during transitions, may overshoot to F-V_{CC}+1.5V for periods <20ns.

CAPACITANCE

Symbol	Parameter	Test conditions	Limits			Unit
			Min	Typ	Max	
C _{IN}	Input capacitance (Address, Control Pins)	T _a = 25°C, f = 1MHz, V _{in} = V _{out} = 0V			8	pF
C _{OUT}	Output capacitance				12	pF

Note: The value of common pins to Flash Memory is the sum of Flash Memory and SRAM.

DC ELECTRICAL CHARACTERISTICS (T_a = -20~ 85°C, F-V_{CC} = 2.7V ~ 3.6V, unless otherwise noted)

Symbol	Parameter	Test conditions	Limits			Unit
			Min	Typ1)	Max	
I _{LI}	Input leakage current	0V ≤ V _{IN} ≤ F-V _{CC}			±2.0	μA
I _{LO}	Output leakage current	0V ≤ V _{OUT} ≤ F-V _{CC}			±11	μA
ISB1	F-V _{CC} standby current	F-V _{CC} = 3.6V, V _{IN} = V _{IL} /V _{IH} , F-CE# = F-RP# = F-WP# = V _{IH}		50	200	μA
ISB2		F-V _{CC} = 3.6V, V _{IN} = GND or F-V _{CC} , F-CE# = F-RP# = F-WP# = F-V _{CC} ± 0.3V		0.1	5	μA
ISB3	F-V _{CC} deep powerdown current	F-V _{CC} = 3.6V, V _{IN} = V _{IL} /V _{IH} , F-RP# = V _{IL}		5	15	μA
ISB4		F-V _{CC} = 3.6V, V _{IN} = GND or V _{CC} , F-RP# = GND ± 0.3V		0.1	5	μA
I _{CC1}	F-V _{CC} read current for Word or Byte	F-V _{CC} = 3.6V, V _{IN} = V _{IL} /V _{IH} , F-CE# = V _{IL} , F-RP# = OE# = V _{IH} , I _{OUT} = 0mA	5MHz	8	15	mA
			1MHz	2	4	
I _{CC2}	F-V _{CC} Write current for Word or Byte	F-V _{CC} = 3.6V, V _{IN} = V _{IL} /V _{IH} , F-CE# = WE# = V _{IL} , F-RP# = OE# = V _{IH}			15	mA
I _{CC3}	F-V _{CC} program current	F-V _{CC} = 3.6V, V _{IN} = V _{IL} /V _{IH} , F-CE# = F-RP# = F-WP# = V _{IH}			35	mA
I _{CC4}	F-V _{CC} erase current	F-V _{CC} = 3.6V, V _{IN} = V _{IL} /V _{IH} , F-CE# = F-RP# = F-WP# = V _{IH}			35	mA
I _{CC5}	F-V _{CC} suspend current	F-V _{CC} = 3.6V, V _{IN} = V _{IL} /V _{IH} , F-CE# = F-RP# = F-WP# = V _{IH}			200	μA
V _{IL}	Input low voltage		-0.5		0.8	V
V _{IH}	Input high voltage		2.0		F-V _{CC} +0.5	V
V _{OL}	Output low voltage	I _{OL} = 4.0mA			0.45	V
V _{OH1}	Output high voltage	I _{OH} = -2.0mA	0.85(F-V _{CC})			V
V _{OH2}		I _{OH} = -100μA	F-V _{CC} -0.4			V
V _{LKO}	Low V _{CC} Lock-Out voltage 2)		1.5		2.2	V

All currents are in RMS unless otherwise noted.

1) Typical values at F-V_{CC}=3.3V, T_a=25°C

2) To protect against initiation of write cycle during V_{CC} power-up/ down, a write cycle is locked out for V_{CC} less than V_{LKO}.

If V_{CC} is less than V_{LKO}, Write State Machine is reset to read mode. When the Write State Machine is in Busy state, if V_{CC} is less than V_{LKO}, the alteration of memory contents may occur.

AC ELECTRICAL CHARACTERISTICS (Ta = -20 ~85°C, F-Vcc = 2.7V ~3.6V)

Read-Only Mode

Symbol		Parameter	Limits			Unit
			F-Vcc=2.7-3.6V			
		90ns				
		Min	Typ	Max		
tRC	tAVAV	Read cycle time	90			ns
t _a (AD)	tAVQV	Address access time			90	ns
t _a (CE)	tELQV	Chip enable access time			90	ns
t _a (OE)	tGLQV	Output enable access time			30	ns
tCLZ	tELQX	Chip enable to output in low-Z	0			ns
tDF(CE)	tEHQZ	Chip enable high to output in high Z			25	ns
tOLZ	tGLQX	Output enable to output in low-Z	0			ns
tDF(OE)	tGHQZ	Output enable high to output in high Z			25	ns
tPHZ	tPLQZ	F-RP# low to output high-Z			150	ns
tOH	tOH	Output hold from F-CE#, OE#, addresses	0			ns
tPS	tPHL	F-RP# recovery to F-CE# low	150			ns

Timing measurements are made under AC waveforms for read operations.

AC ELECTRICAL CHARACTERISTICS (Ta = -20 ~85°C, F-Vcc = 2.7V ~3.6V)

Write Mode (F-WE# control)

Symbol		Parameter	Limits			Unit
			F-Vcc=2.7-3.6V			
		90ns				
		Min	Typ	Max		
tWC	tAVAV	Write cycle time	90			ns
tAS	tAVWH	Address set-up time	50			ns
tAH	tWHAX	Address hold time	0			ns
tDS	tDVWH	Data set-up time	50			ns
tDH	tWHDX	Data hold time	0			ns
tOE#	tWHGL	OE# hold from WE# high	10			ns
tRE	-	Latency between Read and Write FFH or 71H	30			ns
tCS	tELWL	Chip enable set-up time	0			ns
tCH	tWHEH	Chip enable hold time	0			ns
tWP	tWLWH	Write pulse width	60			ns
tWPH	tWHWL	Write pulse width high	30			ns
tGHWL	tGHWL	OE# hold to WE# Low	0			ns
tBLS	tPHHWH	Block Lock set-up to write enable high	90			ns
tBLH	tQVPH	Block Lockhold from valid SRD	0			ns
tDAP	tWHRH1	Duration of auto-program operation		4	80	ms
tDAE	tWHRH2	Duration of auto-block erase operation		40	600	ms
tWHRL	tWHRL	Write enable high to F-RY/BY# low			90	ns
tPS	tPHWL	F-RP# high recovery to write enable low	150			ns

Read timing parameters during command write operations mode are the same as during read-only operations mode.
 Typical values at F-Vcc=3.3V, Ta=25°C

AC ELECTRICAL CHARACTERISTICS (Ta = -20 ~ 85°C, F-Vcc = 2.7V ~ 3.6V)

Write Mode (F-CE# control)

Symbol	Parameter	Limits			Unit	
		F-Vcc=2.7-3.6V				
		90ns				
		Min	Typ	Max		
tWC	tAVAV	Write cycle time	90			ns
tAS	tAVWH	Address set-up time	50			ns
tAH	tEHAX	Address hold time	0			ns
tDS	tDVWH	Data set-up time	50			ns
tDH	tEHDX	Data hold time	0			ns
tOE#	tEHGL	OE# hold from CE# high	10			ns
tRE	-	Latency between Read and Write FFH or 71H	30			ns
tWS	tWLEL	Write enable set-up time	0			ns
tWH	tEHWL	Write enable hold time	0			ns
tCEP	tELEH	F-CE# pulse width	60			ns
tCEPH	tEHEL	F-CE# pulse width high	30			ns
tGH	tGHEL	OE# hold to F-CE# Low	90			ns
tBLS	tPHHEH	Block Lock set-up to chip enable high	90			ns
tBLH	tQVPH	Block Lockhold from valid SRD	0			ns
tDAP	tEHRH1	Duration of auto-program operation		4	80	ms
tDAE	tEHRH2	Duration of auto-block erase operation		40	600	ms
tEHL	tEHL	F-CE# high to F-RY/BY# low			90	ns
tPS	tPHWL	F-RP# high recovery to write enable low	150			ns

Read timing parameters during command write operation mode are the same as during read-only operation mode.
 Typical values at F-Vcc=3.3V, Ta=25°C

Erase and Program Performance

Parameter	Min	Typ	Max	Unit
Block Erase Time		40	600	ms
Main Block Write Time (Page Mode)		1.0	1.8	sec
Page Write Time		4	80	ms

Program Suspend Latency / Erase Suspend Time

Parameter	Min	Typ	Max	Unit
Program Suspend Latency			15	μs
Erase Suspend Time			15	μs

Please see page 20.

Vcc Power Up / Down Timing

Symbol	Parameter	Min	Typ	Max	Unit
tVCS	F-RP# =VIH set-up time from Vccmin	2			μs

Please see page 13.

During power up/down, by the noise pulses on control pins, the device has possibility of accidental erasure or programming. The device must be protected against initiation of write cycle for memory contents during power up/down. The delay time of min.2μsec is always required before read operation or write operation is initiated from the time F-Vcc reaches F-Vccmin during power up/down. By holding F-RP# VIL, the contents of memory is protected during F-Vcc power up/down. During power up, F-RP# must be held VIL for min.2μs from the time F-Vcc reaches F-Vccmin. During power down, F-RP# must be held VIL until Vcc reaches GND. F-RP# doesn't have latch mode ,therefore F-RP# must be held VIH during read operation or erase/program operation.

MITSUBISHI LSIs
M6MGB/T162S4BVP
 16,777,216-BIT (1,048,576 -WORD BY 16-BIT) CMOS
 3.3V-ONLY FLASH MEMORY &
 4,194,304-BIT (524,288-WORD BY 8-BIT) CMOS SRAM
 Stacked-MCP (Multi Chip Package)

V_{CC} POWER UP / DOWN TIMING

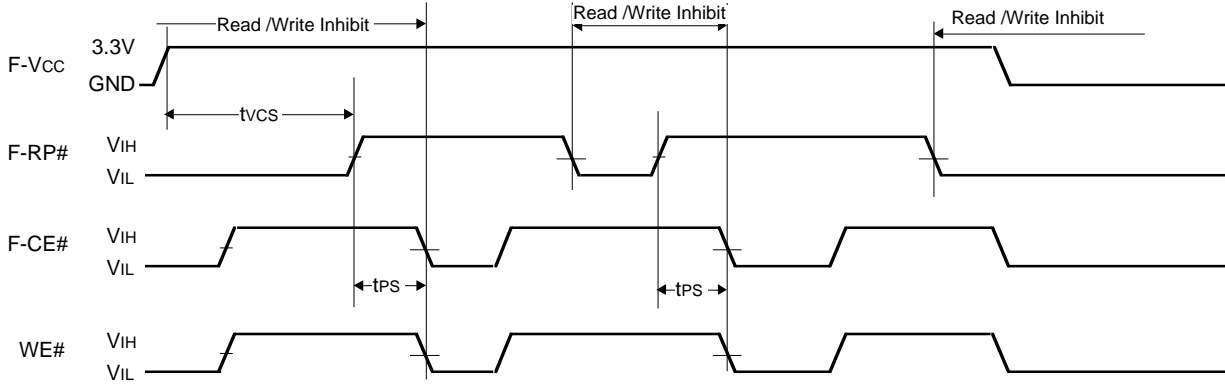

AC WAVEFORMS FOR READ OPERATION AND TEST CONDITIONS

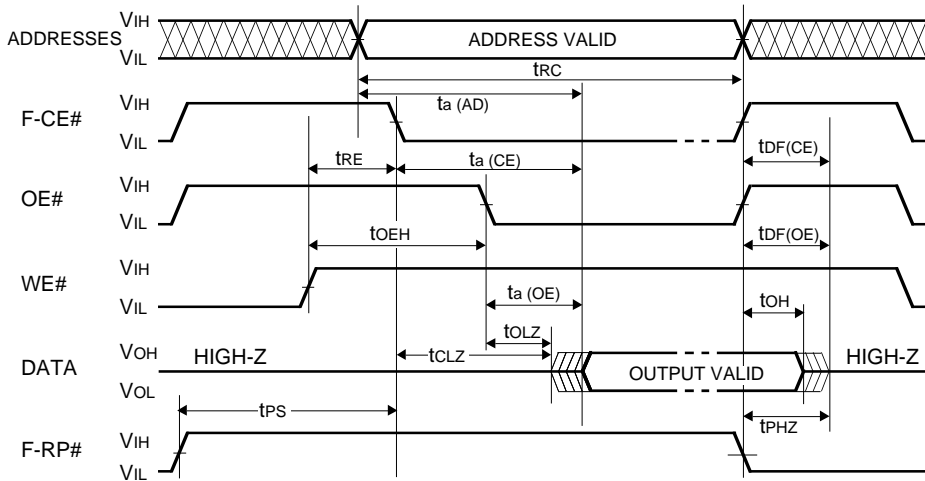

TEST CONDITIONS
FOR AC CHARACTERISTICS

Input voltage : $V_{IL} = 0V, V_{IH} = 3.0V$
 Input rise and fall times : $\leq 5ns$
 Reference voltage
 at timing measurement : $1.5V$

Output load : 1TTL gate +
CL(30pF)

or

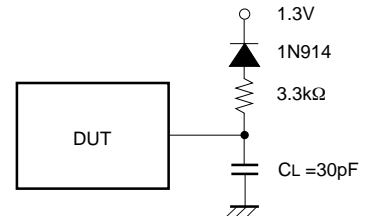

AC WAVEFORMS FOR WRITE FFH or 71H AND READ OPERATION

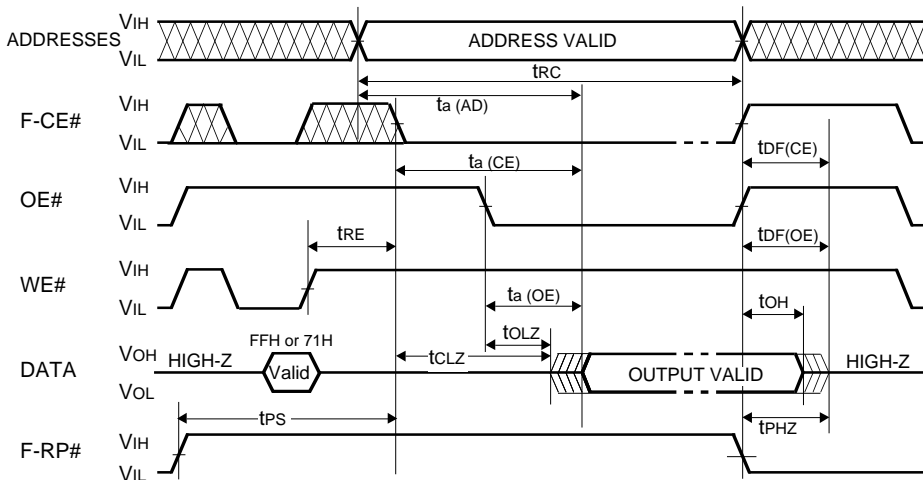

In the case of use F-CE# is Low fixed, it is allowed to define a timing specification of t_{RE} from rising edge of WE# to falling edge of OE#, and valid data is read after spec of $t_{RE} + t_a(CE)$. (This is only for FFH,71H program and read)

MITSUBISHI LSIs
M6MGB/T162S4BVP
 16,777,216-BIT (1,048,576 -WORD BY 16-BIT) CMOS
 3.3V-ONLY FLASH MEMORY &
 4,194,304-BIT (524,288-WORD BY 8-BIT) CMOS SRAM
 Stacked-MCP (Multi Chip Package)

AC WAVEFORMS FOR PAGE PROGRAM OPERATION (WE# control)

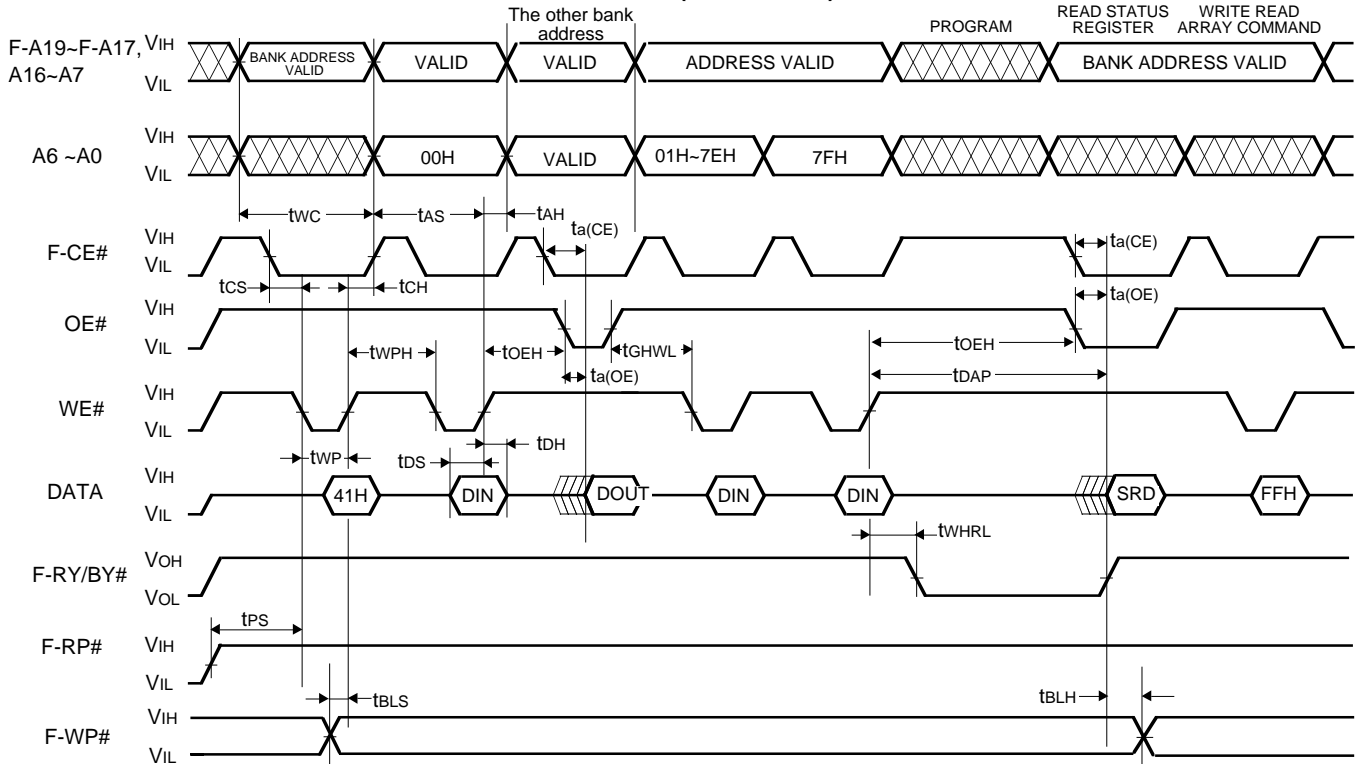

AC WAVEFORMS FOR PAGE PROGRAM OPERATION (F-CE# control)

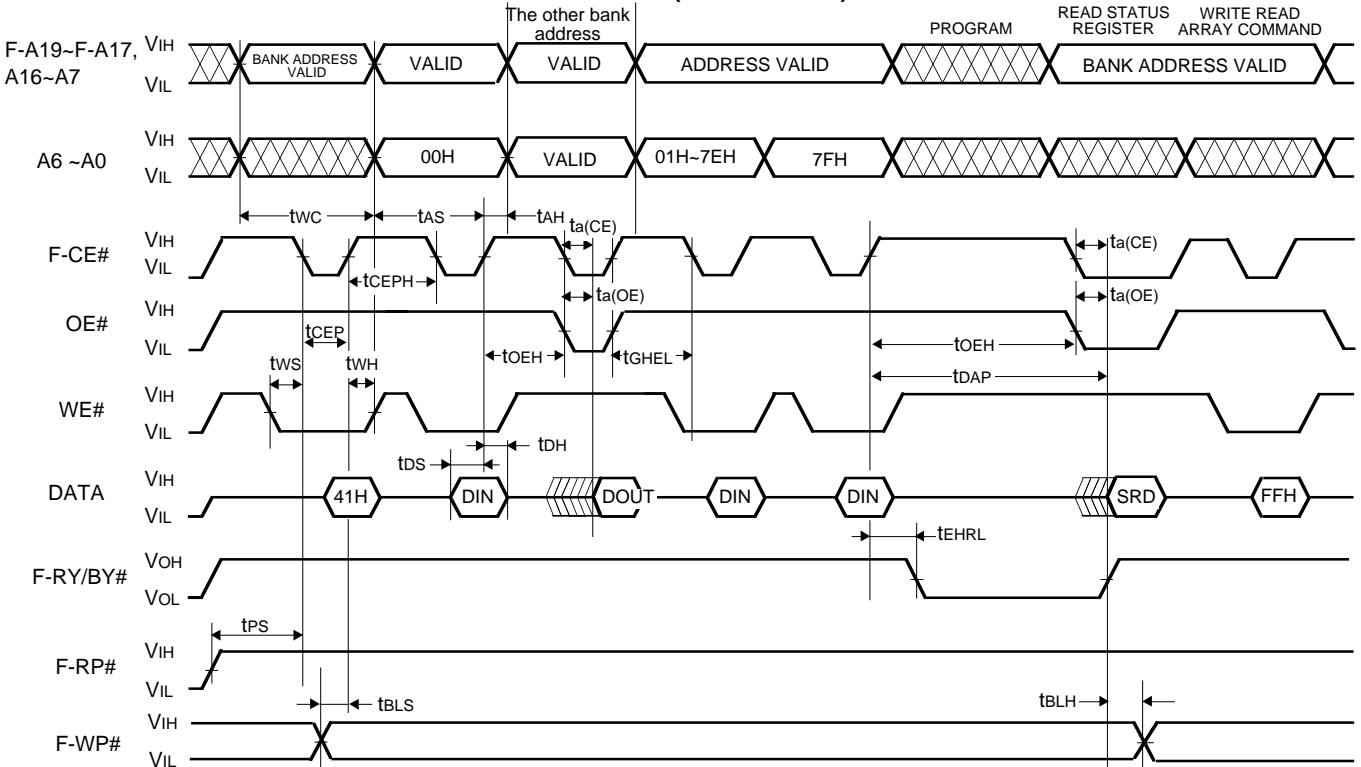

AC WAVEFORMS FOR WORD PROGRAM OPERATION (WE# control) (to only BANK(I))

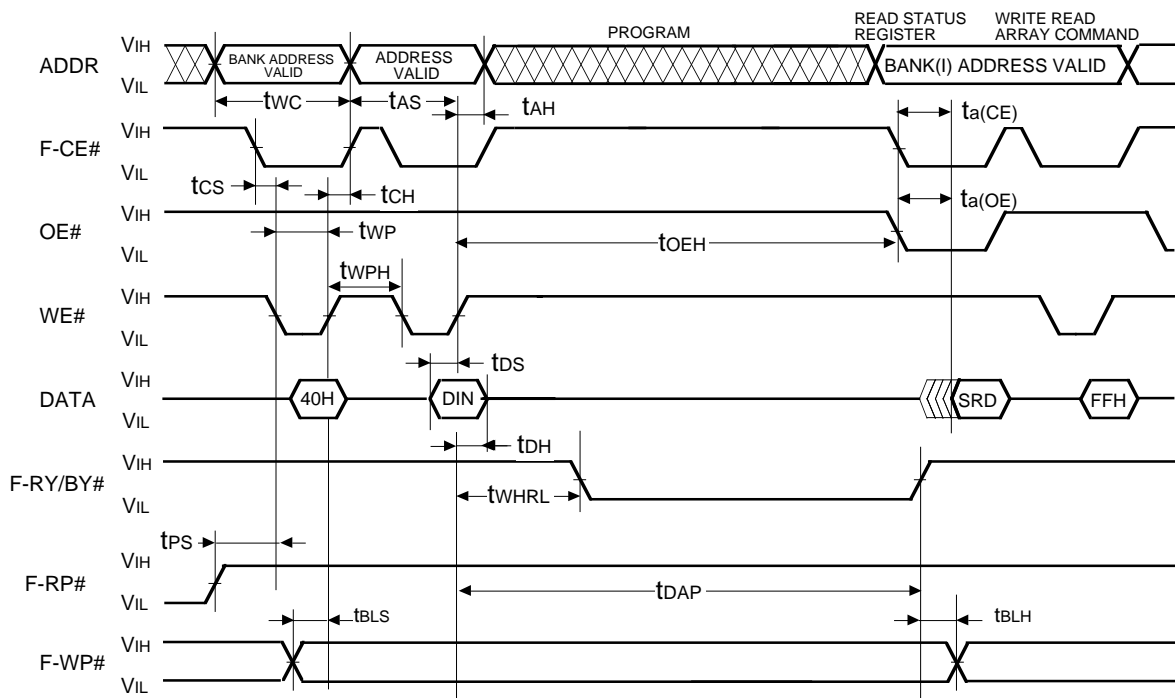

AC WAVEFORMS FOR WORD PROGRAM OPERATION (F-CE# control) (to only BANK(I))

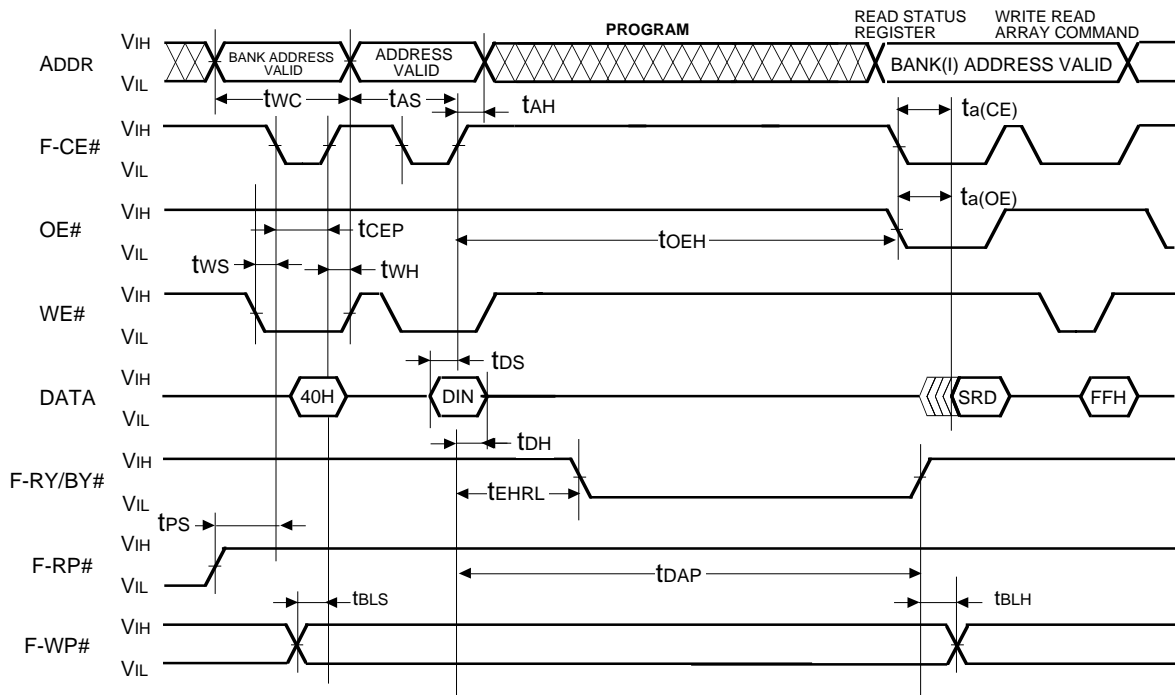

AC WAVEFORMS FOR ERASE OPERATIONS (WE# control)

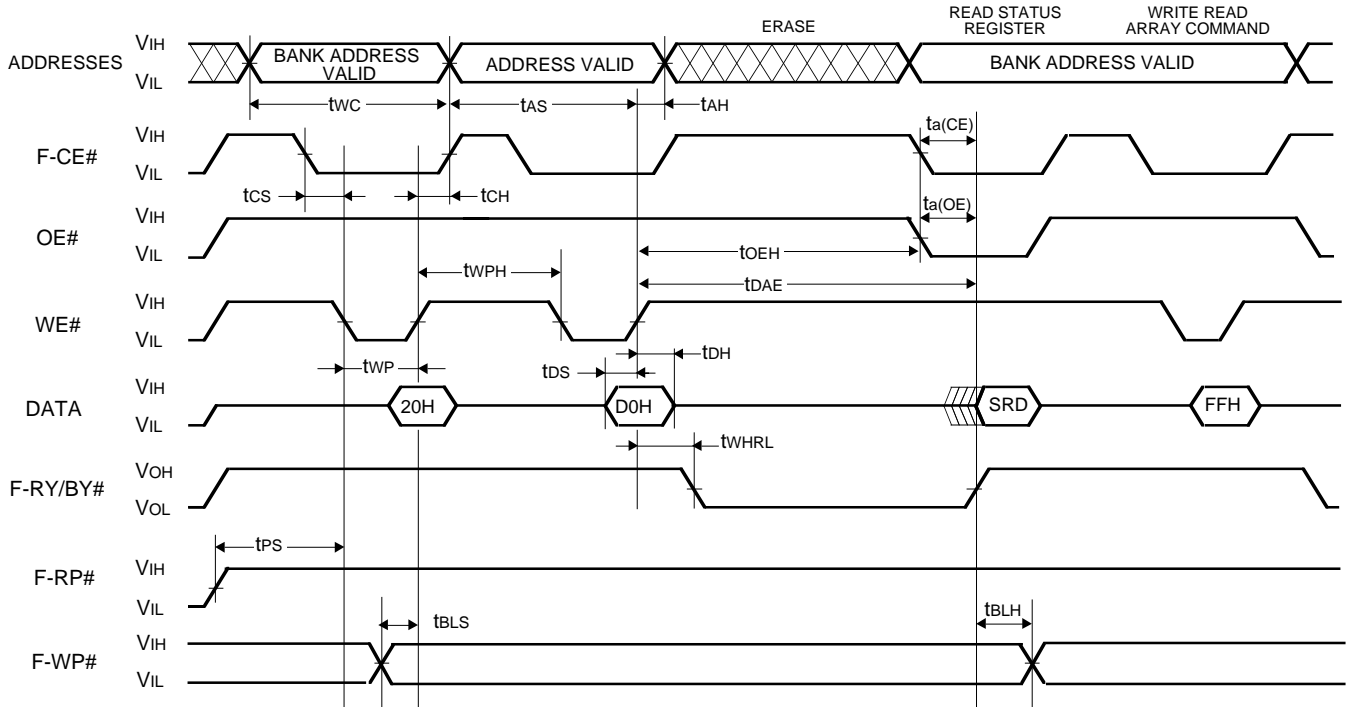

AC WAVEFORMS FOR ERASE OPERATIONS (F-CE# control)

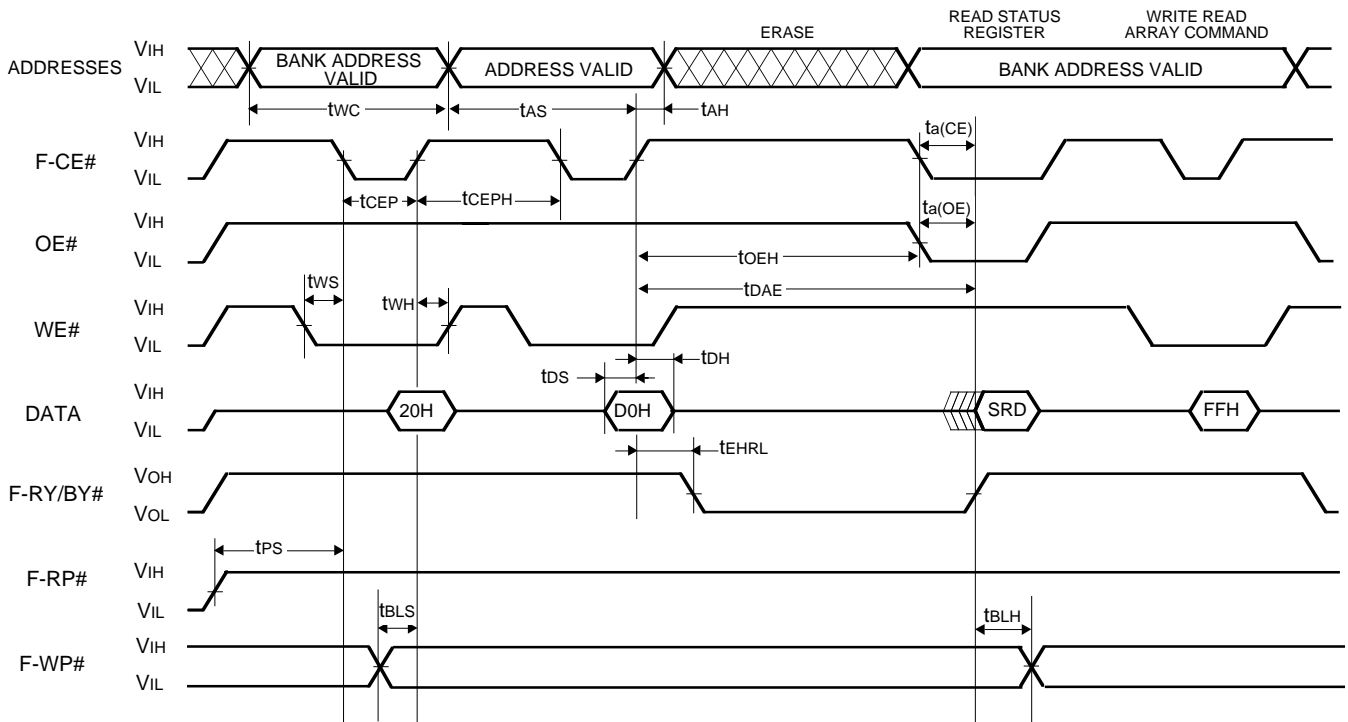

AC WAVEFORMS FOR PAGE PROGRAM OPERATION WITH BGO (WE# control)

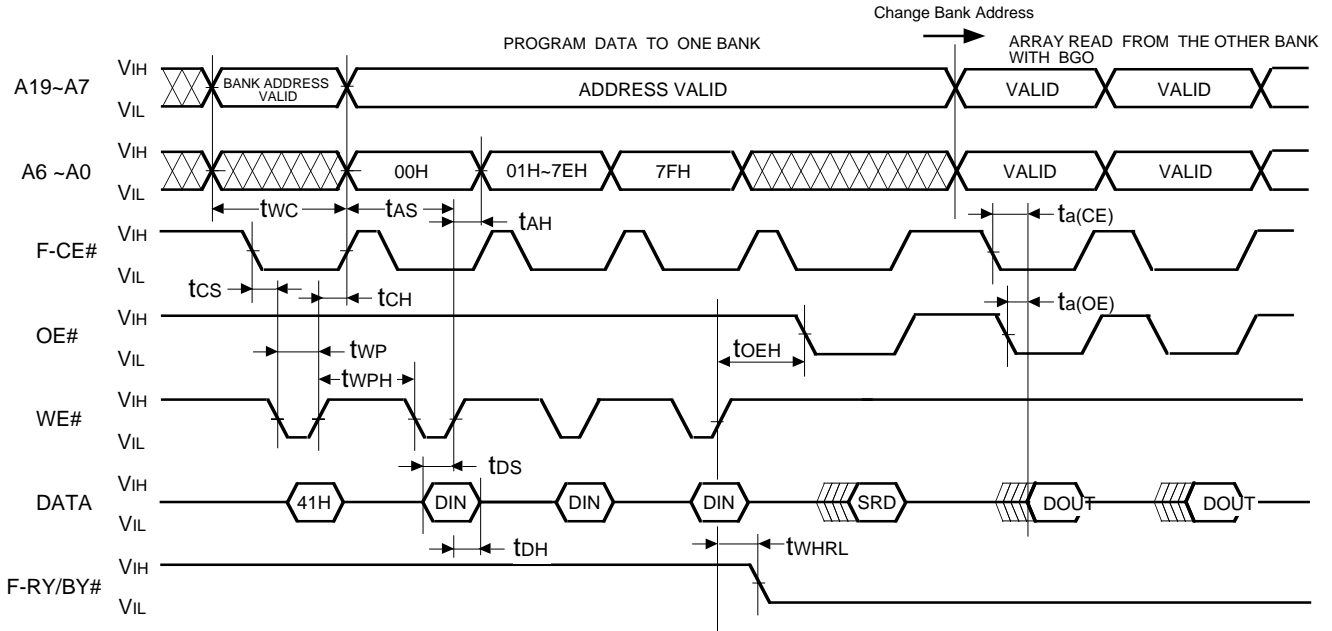

AC WAVEFORMS FOR PAGE PROGRAM OPERATION WITH BGO (F-CE# control)

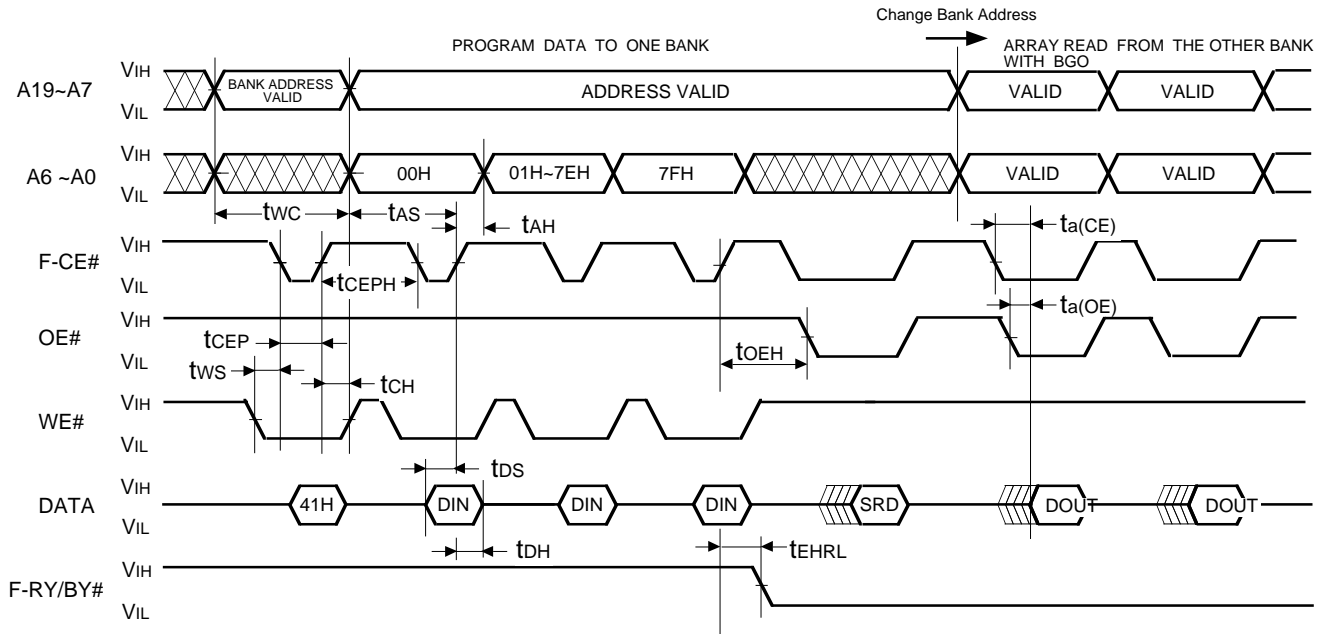

AC WAVEFORMS FOR WORD PROGRAM OPERATION WITH BGO (WE# control)

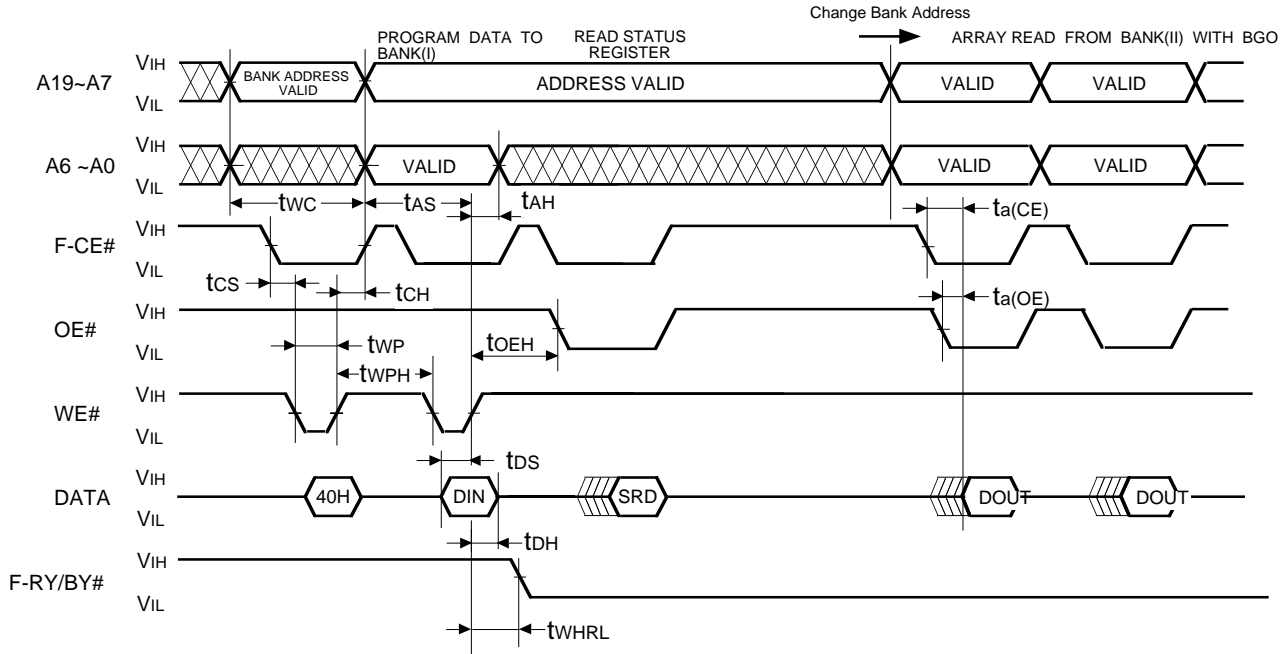

AC WAVEFORMS FOR WORD PROGRAM OPERATION WITH BGO (F-CE# control)

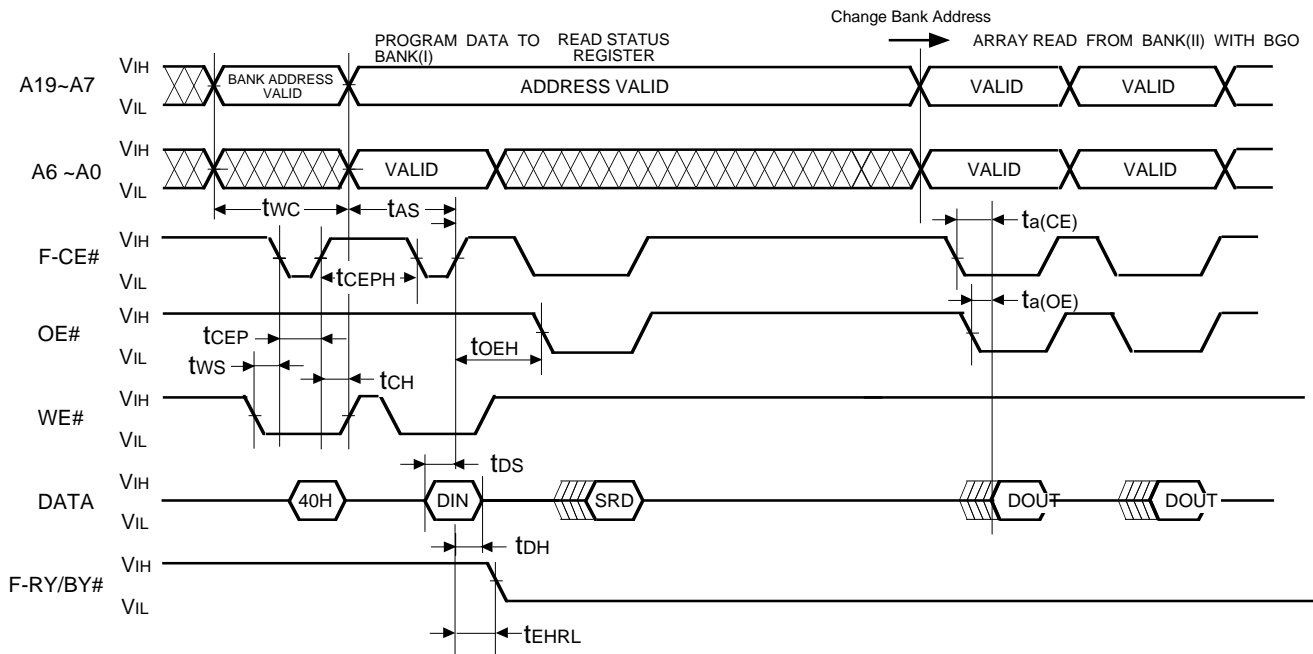

AC WAVEFORMS FOR BLOCK ERASE OPERATION WITH BGO (WE# control)

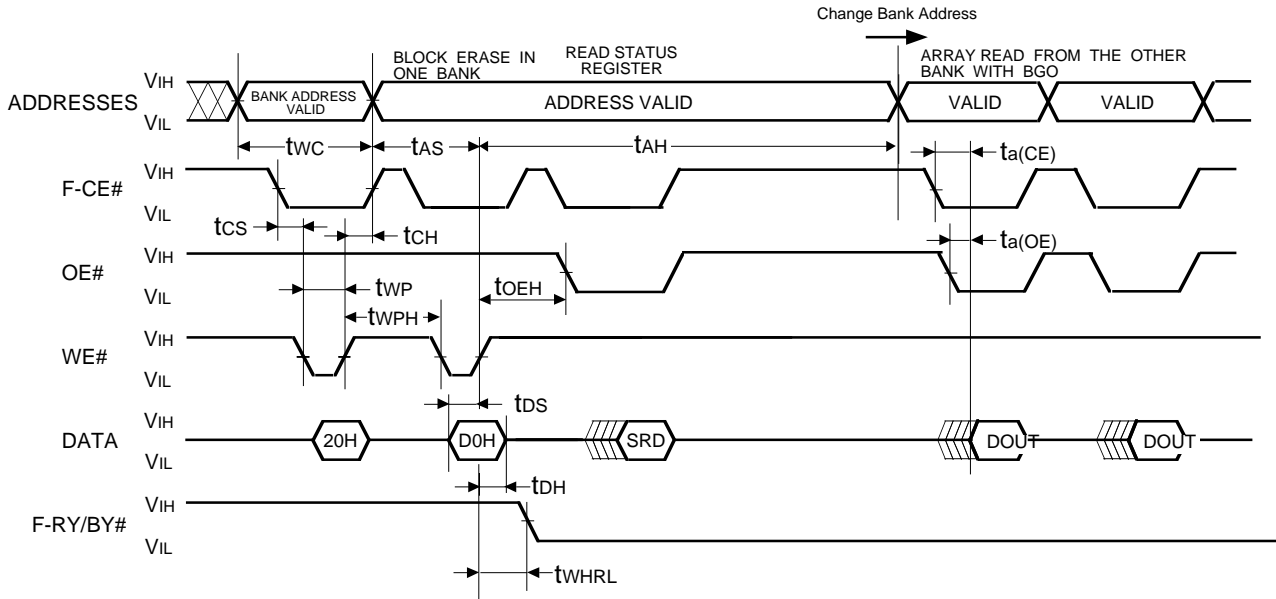

AC WAVEFORMS FOR BLOCK ERASE OPERATION WITH BGO (F-CE# control)

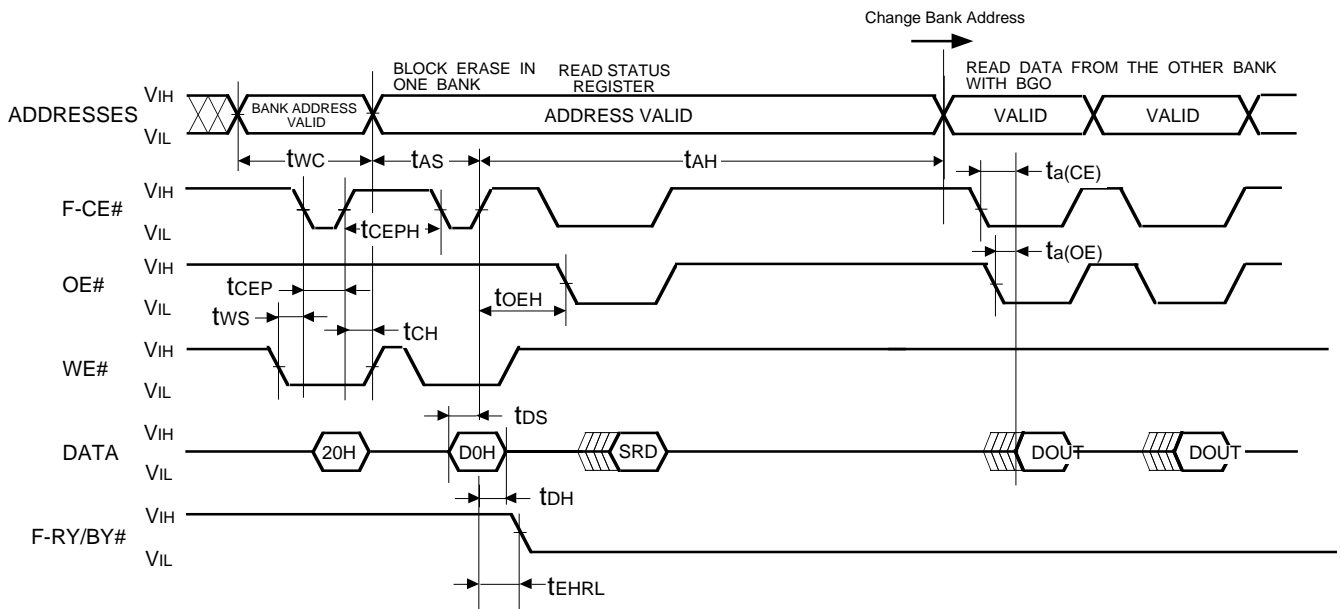

AC WAVEFORMS FOR SUSPEND OPERATION (WE# control)

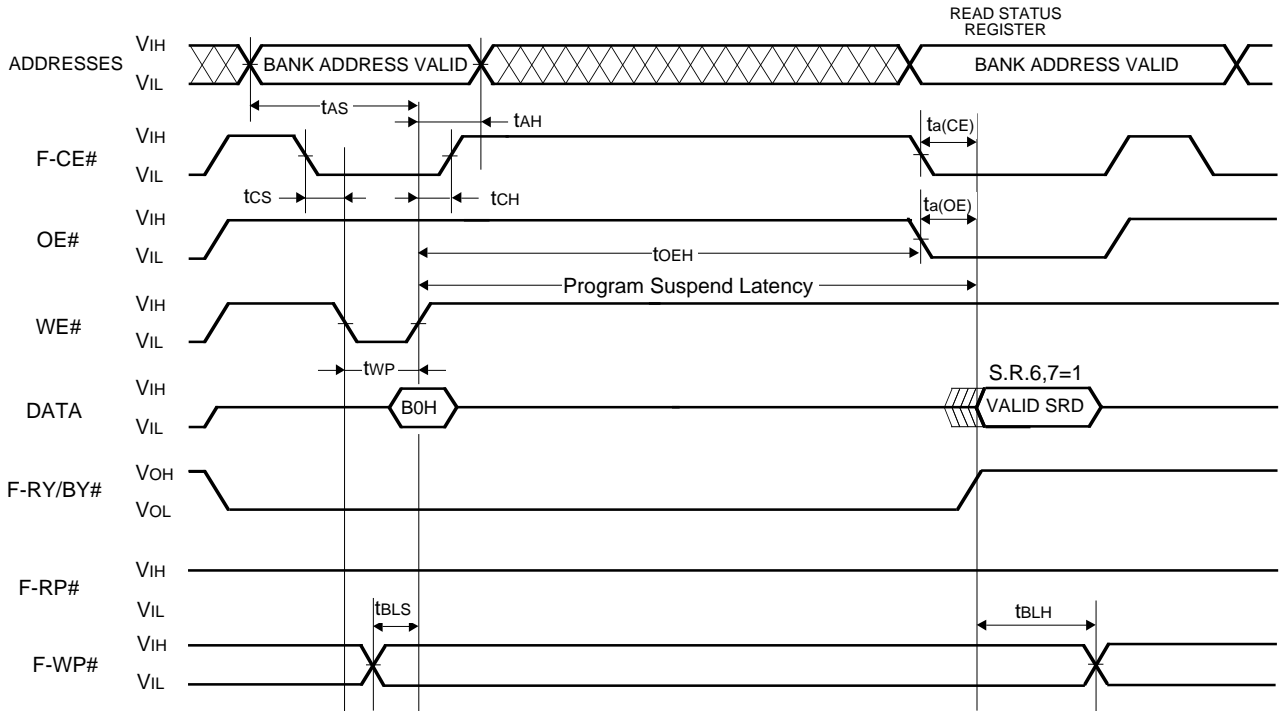

AC WAVEFORMS FOR SUSPEND OPERATION (F-CE# control)

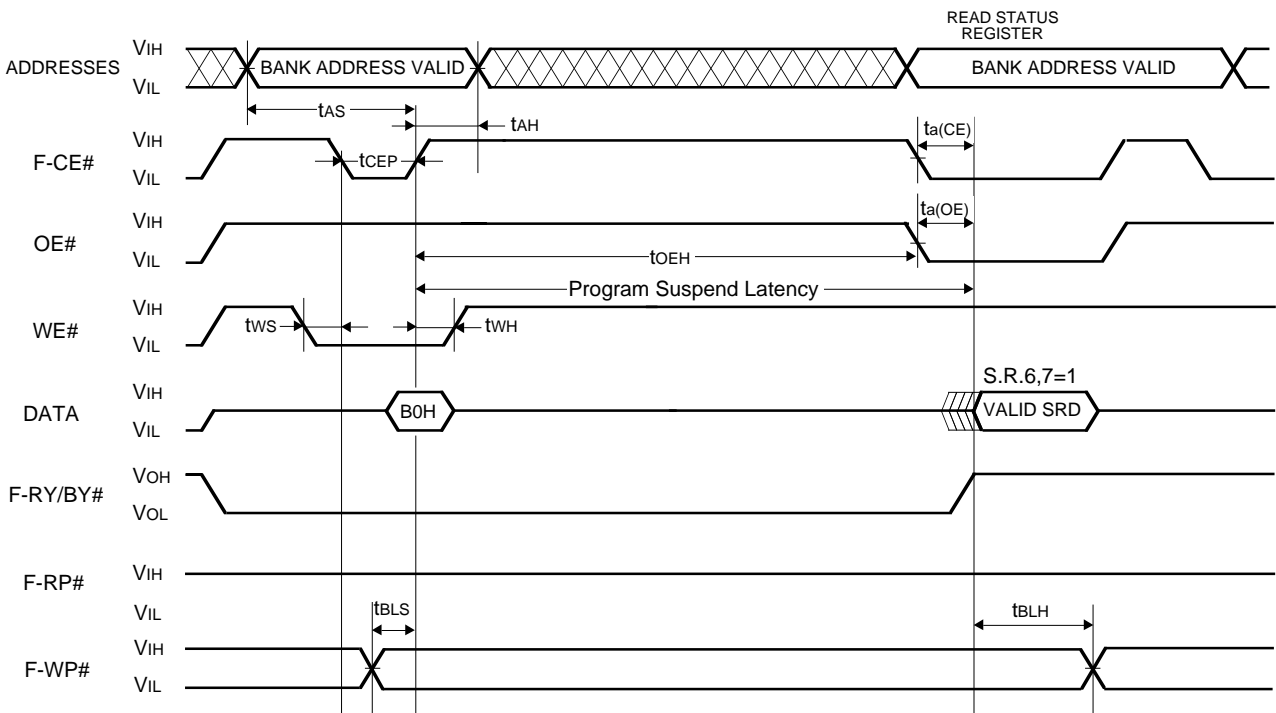

FULL STATUS CHECK PROCEDURE

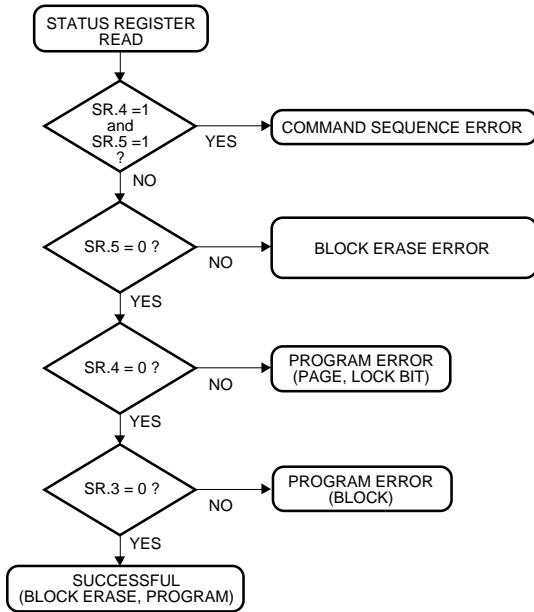

LOCK BIT PROGRAM FLOW CHART

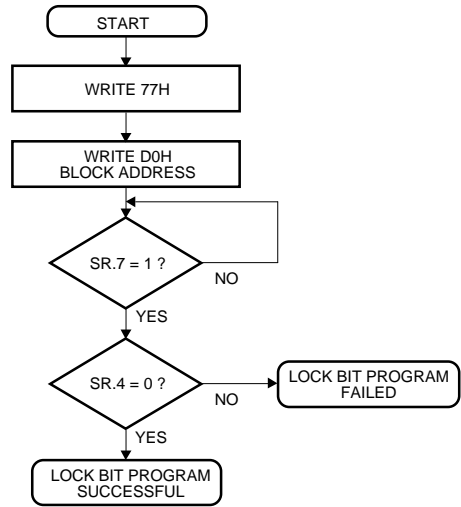

BYTE PROGRAM FLOW CHART

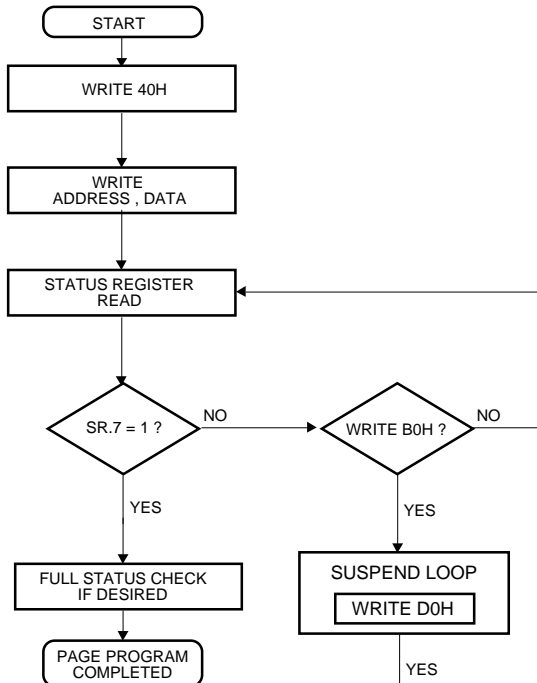

* Word program is admitted to only BANK(I).

PAGE PROGRAM FLOW CHART

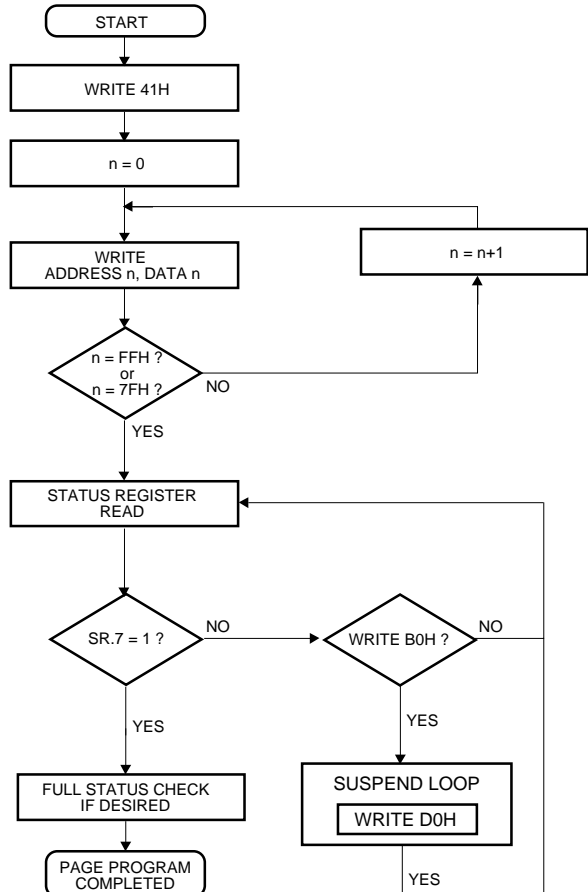

CLEAR PAGE BUFFER

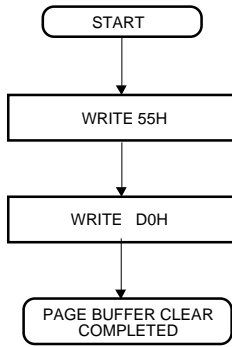

SINGLE DATA LOAD TO PAGE BUFFER

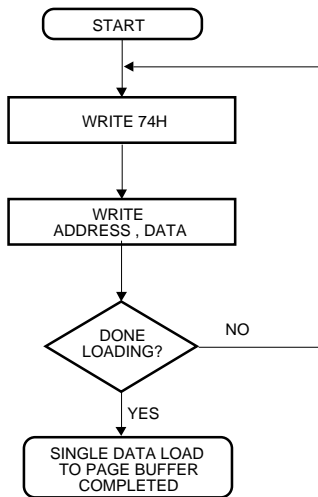

PAGE BUFFER TO FLASH

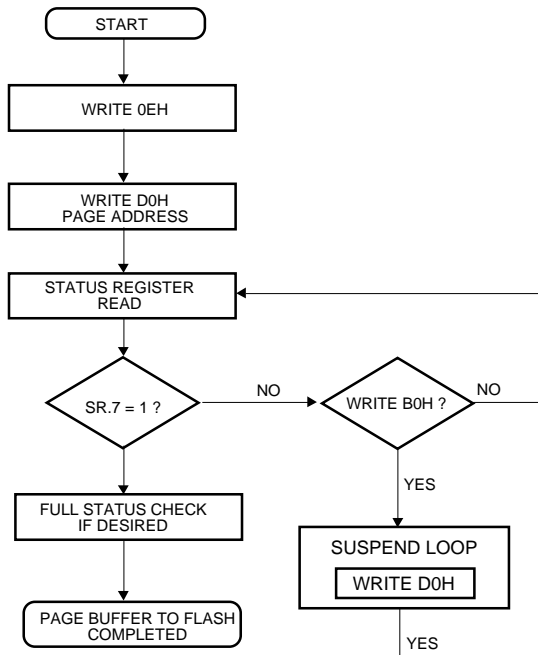

SUSPEND / RESUME FLOW CHART

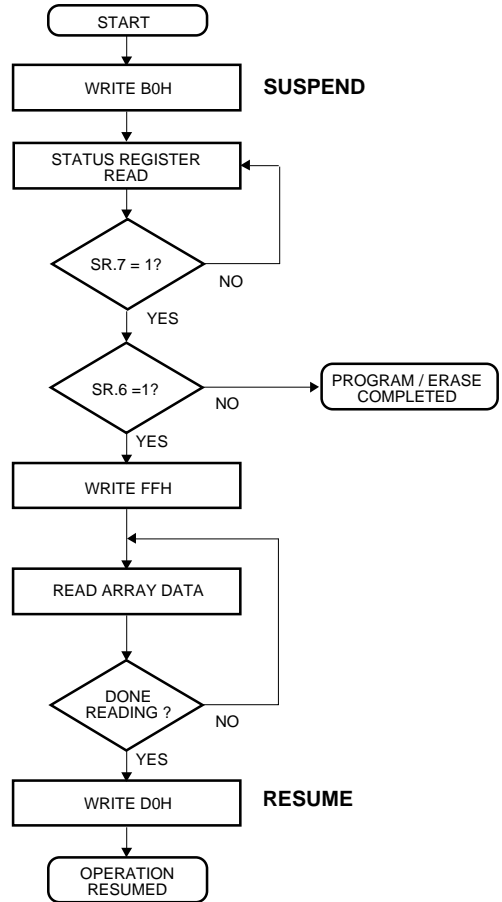

* The bank address is required when writing this command. Also, there is no need to suspend the erase or program operation when reading data from the other bank. Please use BGO function.

BLOCK ERASE FLOW CHART

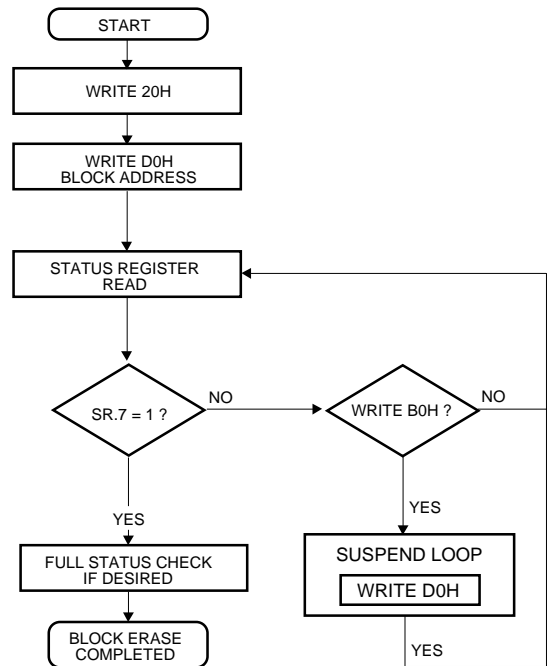

MITSUBISHI LSIS
M6MGB/T162S4BVP
 16,777,216-BIT (1,048,576 -WORD BY 16-BIT) CMOS
 3.3V-ONLY FLASH MEMORY &
 4,194,304-BIT (524,288-WORD BY 8-BIT) CMOS SRAM
 Stacked-MCP (Multi-Chip Package)

OPERATION STATUS and EFFECTIVE COMMAND

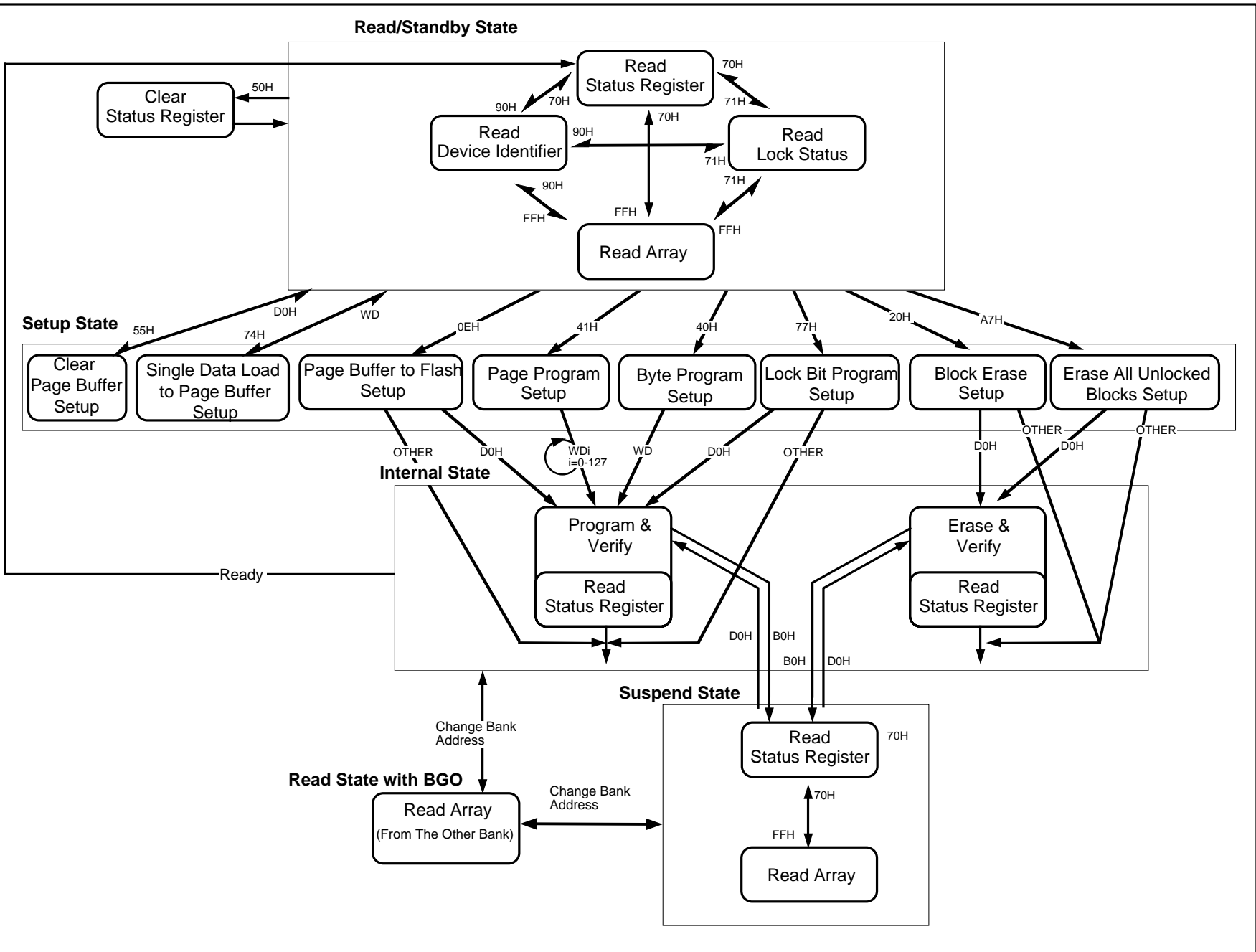

2. SRAM

The SRAM of M6MGB/T162S4BVP is organized as 524,288-word by 8-bit. These devices operate on a single +2.7~3.6V powersupply, and are directly TTL compatible to both input and output. Its fully static circuit needs no clocks and no refresh, and makes it useful.

The operation mode are determined by a combination of the device control inputs , S-CE , WE# and OE#. Each mode is summarized in the function table.

A write operation is executed whenever the low level WE# overlaps with the high level S-CE. The address S-A-1~A17 must be set up before the write cycle and must be stable during the entire cycle.

A read operation is executed by setting WE# at a high level and OE# at a low level while S-CE are in an active state(S-CE=H).

When setting S-CE at a low level,the chips are in a non-selectable mode in which both reading and writing are disabled. In this mode, the output stage is in ahigh-impedance state, allowing OR-tie with other chips and memory expansion by S-CE.

The power supply current is reduced as low as 0.3 μ A(25 °C,typical), and the memory data can be held at +2V powersupply, enabling battery back-up operation during power failure or power-down operation in the non-selected mode.

FUNCTION TABLE

S-CE	WE#	OE#	Mode	DQ0~7	Icc
L	X	X	Non selection	High-Z	Standby
H	L	X	Write	Din	Active
H	H	L	Read	Dout	Active
H	H	H	————	High-Z	Active

ABSOLUTE MAXIMUM RATINGS

Symbol	Parameter	Conditions	Ratings	Units
S-V _{CC}	Supply voltage	With respect to GND	-0.5* ~ +4.6	V
V _I	Input voltage	With respect to GND	-0.5* ~ S-V _{CC} + 0.5	
V _O	Output voltage	With respect to GND	0 ~ S-V _{CC}	
P _d	Power dissipation	T _a =25°C	700	mW
T _a	Operating temperature	W-version	- 20 ~ +85	°C
T _{stg}	Storage temperature		- 65 ~ +150	°C

* -3.0V in case of AC (Pulse width ≤ 30ns)

DC ELECTRICAL CHARACTERISTICS

(S-V_{CC}=2.7 ~ 3.6V, unless otherwise noted)

Symbol	Parameter	Conditions	Limits			Units		
			Min	Typ	Max			
V _{IH}	High-level input voltage		2.2		S-V _{CC} +0.3V	V		
V _{IL}	Low-level input voltage		-0.3 *		0.6			
V _{OH1}	High-level output voltage 1	I _{OH} = -0.5mA	2.4					
V _{OH2}	High-level output voltage 2	I _{OH} = -0.05mA	S-V _{CC} -0.5V					
V _{OL}	Low-level output voltage	I _{OL} =2mA			0.4			
I _I	Input leakage current	V _I =0 ~ S-V _{CC}			±1	μA		
I _O	Output leakage current	S-CE=V _{IL} or OE#=V _{IH} , V _{I/O} =0 ~ S-V _{CC}			±1	μA		
I _{CC1}	Active supply current (AC, MOS level)	S-CE ≥ S-V _{CC} -0.2V other inputs ≤ 0.2V or ≥ S-V _{CC} -0.2V Output - open (duty 100%)	f= 10MHz	-	50	70	mA	
			f= 1MHz	-	7	15		
I _{CC2}	Active supply current (AC, TTL level)	S-CE=V _{IH} other pins =V _{IH} or V _{IL} Output - open (duty 100%)	f= 10MHz	-	50	70	mA	
			f= 1MHz	-	7	15		
I _{CC3}	Stand by supply current (AC, MOS level)	S-CE ≤ 0.2V Other inputs=0~S-V _{CC}	-W	+70 ~ +85°C	-	-	40	μA
				+40 ~ +70°C	-	-	20	
				+25 ~ +40°C	-	1	3.6	
				- 20 ~ +25°C	-	0.3	1.2	
I _{CC4}	Stand by supply current (AC, TTL level)	S-CE=V _{IL} Other inputs= 0 ~ S-V _{CC}		-	-	0.5	mA	

Note 1: Direction for current flowing into IC is indicated as positive (no mark)

* -3.0V in case of AC (Pulse width ≤ 30ns)

Note 2: Typical value is for S-V_{CC}=3.0V and T_a=25 °C

CAPACITANCE

(S-V_{CC}=2.7 ~ 3.6V, unless otherwise noted)

Symbol	Parameter	Conditions	Limits			Units
			Min	Typ	Max	
C _I	Input capacitance	V _I =GND, V _I =25mVrms, f=1MHz			10	pF
C _O	Output capacitance	V _O =GND, V _O =25mVrms, f=1MHz			10	

Note: The value of common pins to SRAM is the sum of Flash Memory and SRAM.

AC ELECTRICAL CHARACTERISTICS (S-V_{cc}=2.7 ~ 3.6V, unless otherwise noted)

(1) TEST CONDITIONS

Supply voltage	2.7V~3.6V
Input pulse	V _{IH} =2.4V, V _{IL} =0.4V
Input rise time and fall time	5ns
Reference level	V _{OH} =V _{OL} =1.5V Transition is measured ±500mV from steady state voltage.(for t _{en} , t _{dis})
Output loads	Fig.1, CL=30pF CL=5pF (for t _{en} , t _{dis})

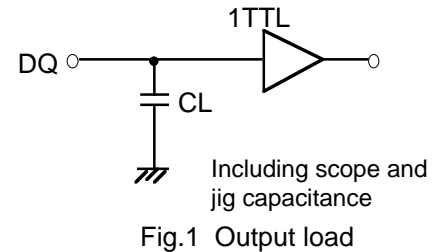

(2) READ CYCLE

Symbol	Parameter	Limits		Units
		SRAM		
		Min	Max	
t _{CR}	Read cycle time	85		ns
t _{a(A)}	Address access time		85	ns
t _{a(CE)}	Chip select access time		85	ns
t _{a(OE)}	Output enable access time		45	ns
t _{dis(CE)}	Output disable time after S-CE low		30	ns
t _{dis(OE)}	Output disable time after OE# high		30	ns
t _{en(CE)}	Output enable time after S-CE high	10		ns
t _{en(OE)}	Output enable time after OE# low	5		ns
t _{v(A)}	Data valid time after address	10		ns

(3) WRITE CYCLE

Symbol	Parameter	Limits		Units
		SRAM		
		Min	Max	
t _{cw}	Write cycle time	85		ns
t _{w(W)}	Write pulse width	60		ns
t _{su(A)}	Address setup time	0		ns
t _{su(A-WH)}	Address setup time with respect to WE#	70		ns
t _{su(CE)}	Chip select setup time	70		ns
t _{su(D)}	Data setup time	35		ns
t _{h(D)}	Data hold time	0		ns
t _{rec(W)}	Write recovery time	0		ns
t _{dis(W)}	Output disable time from WE# low		30	ns
t _{dis(OE)}	Output disable time from OE# high		30	ns
t _{en(W)}	Output enable time from WE# high	5		ns
t _{en(OE)}	Output enable time from OE# low	5		ns

(4)TIMING DIAGRAMS

Read cycle

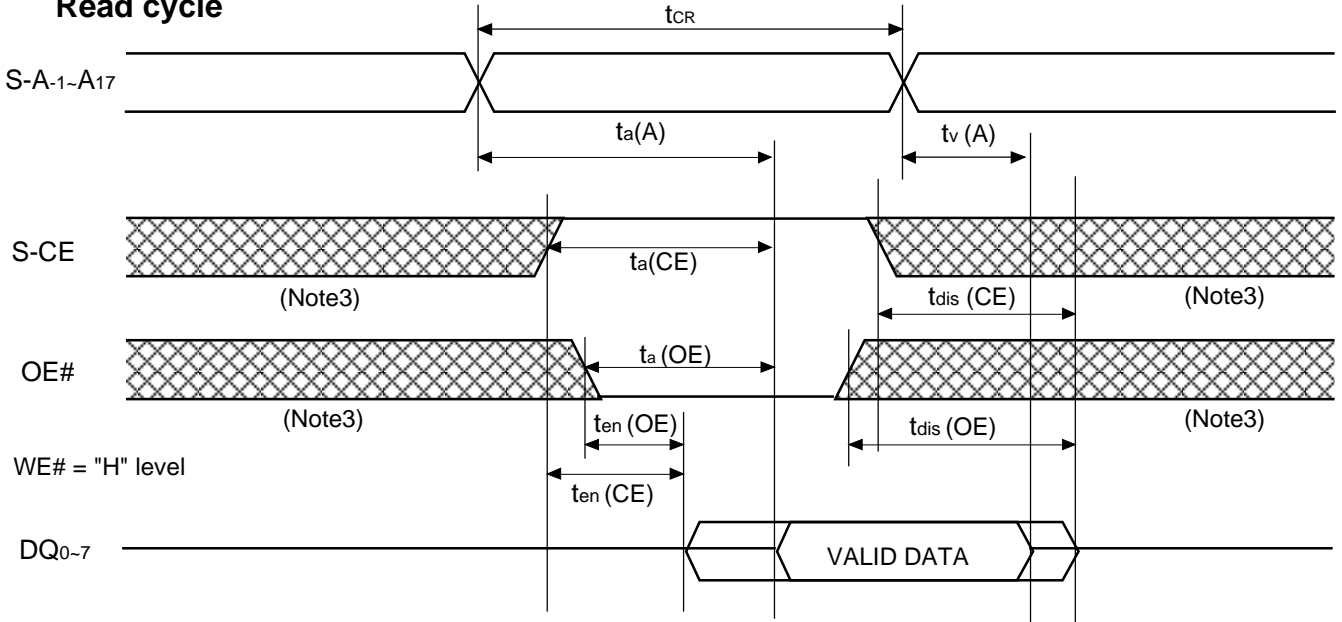

Write cycle (WE# control mode)

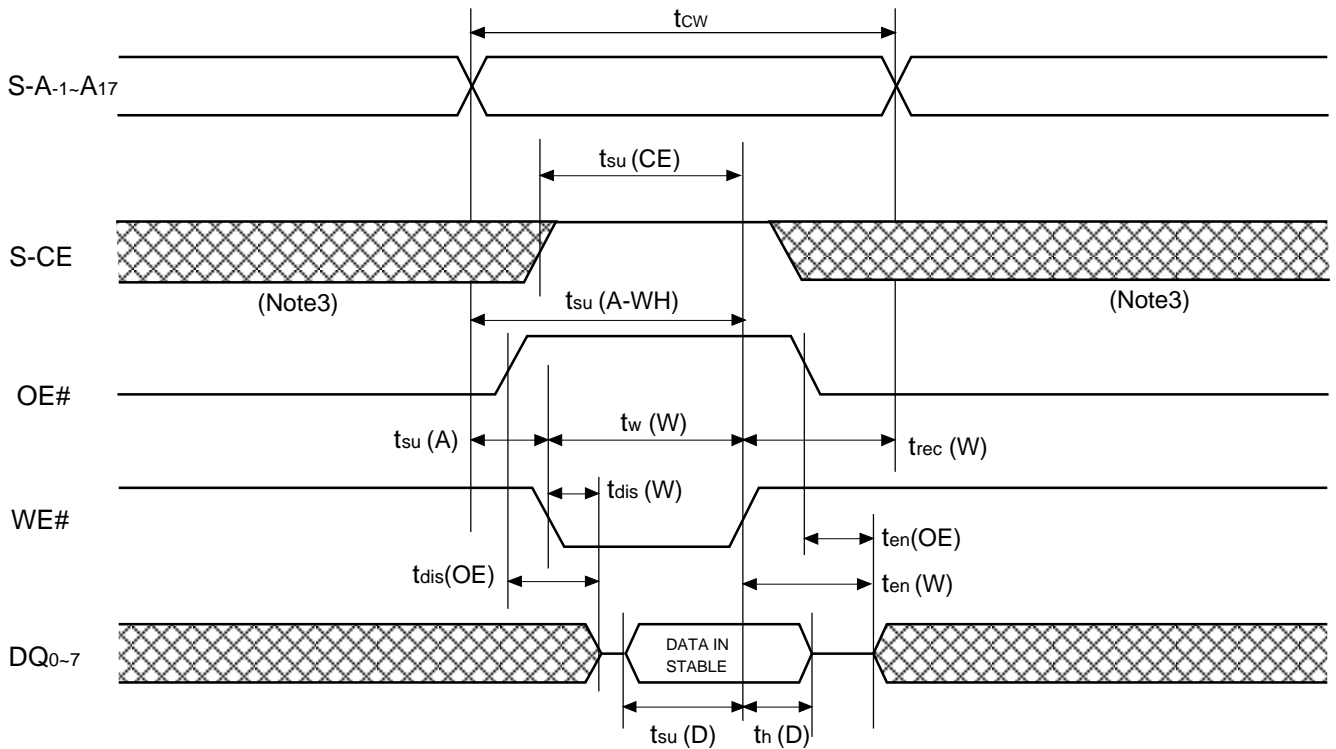

Write cycle (S-CE control mode)

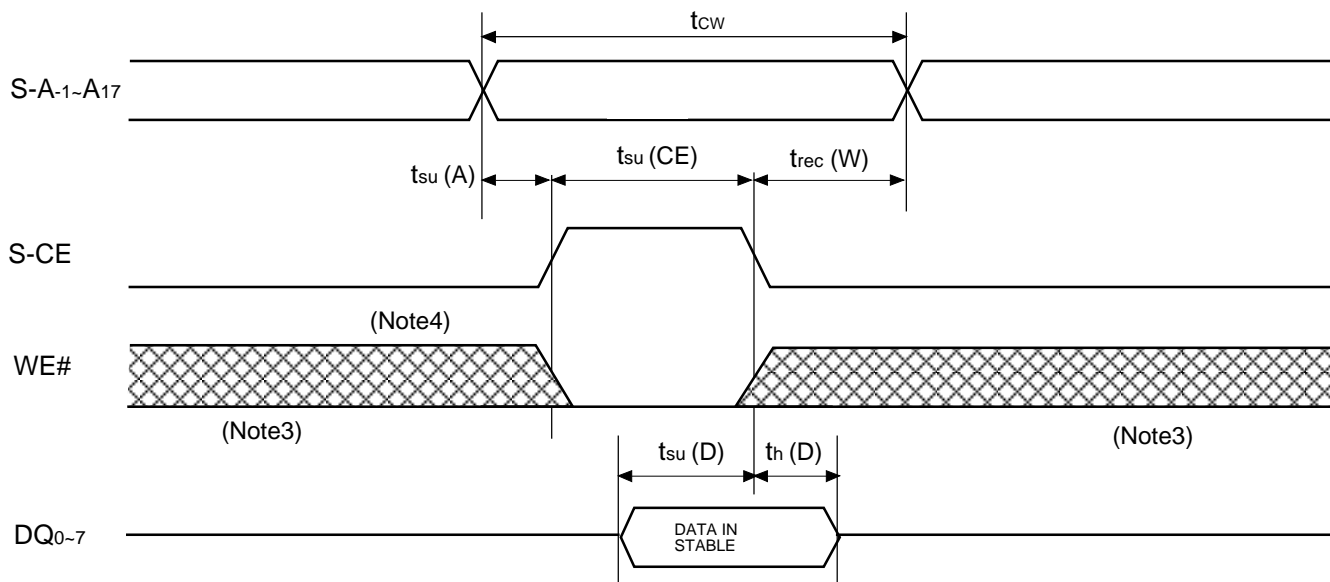

Note 3: Hatching indicates the state is "don't care".

Note 4: When the falling edge of WE# is simultaneously or prior to the rising edge of S-CE, the outputs are maintained in the high impedance state.

Note 5: Don't apply inverted phase signal externally when DQ pin is in output mode.