

256K X 36 FUNCTIONAL BLOCK DIAGRAM

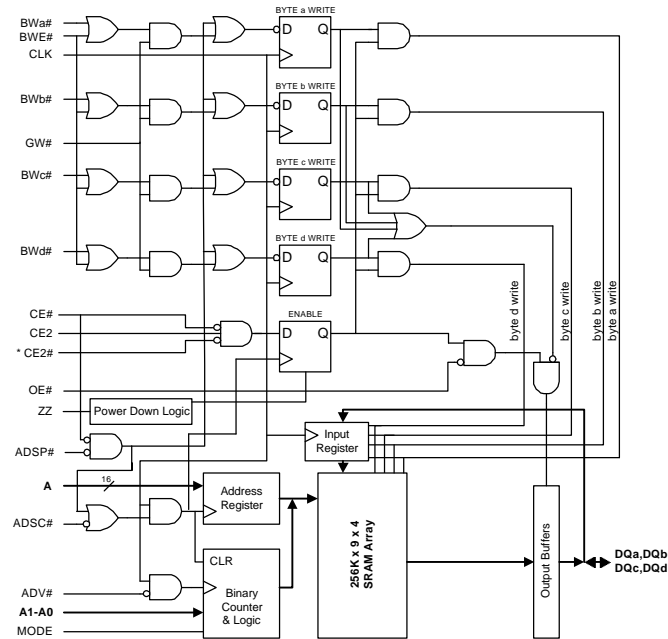

* Note: CE2# is for TA version only.

512K X 18 FUNCTIONAL BLOCK DIAGRAM

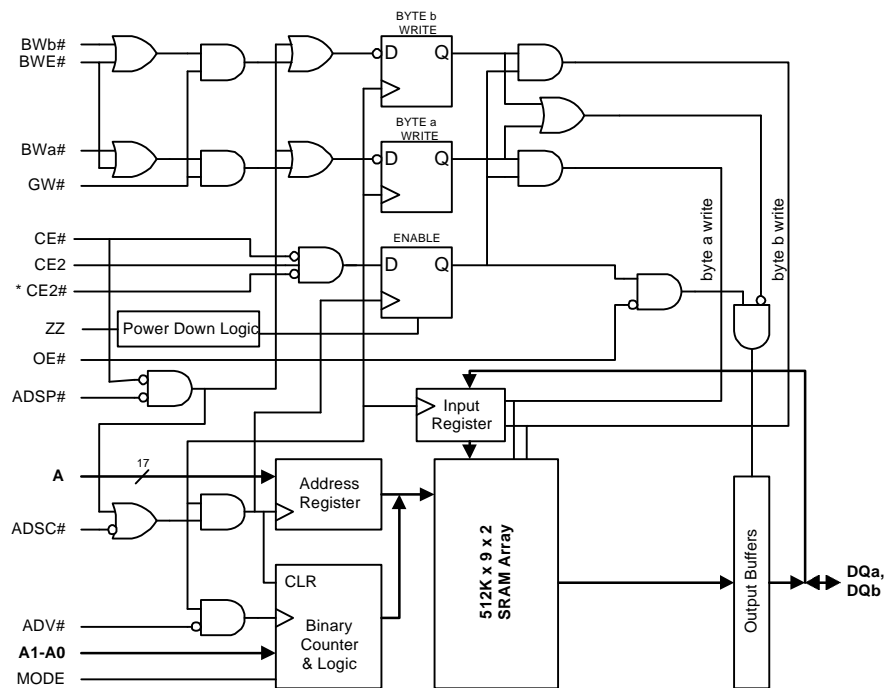

* Note: CE2# is for TA version only.

NOTE: The Functional Block Diagram illustrates simplified device operation. See Truth Table, pin descriptions and timing diagrams for detailed information.

PIN ASSIGNMENTS (TOP VIEW)

256Kx36, 100-Pin TQFP, T Package Version

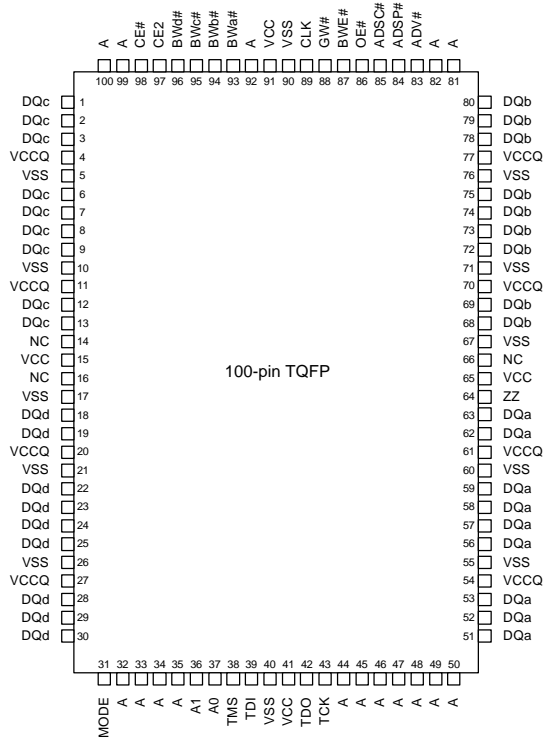

256Kx36, 100-Pin TQFP, TA Package Version

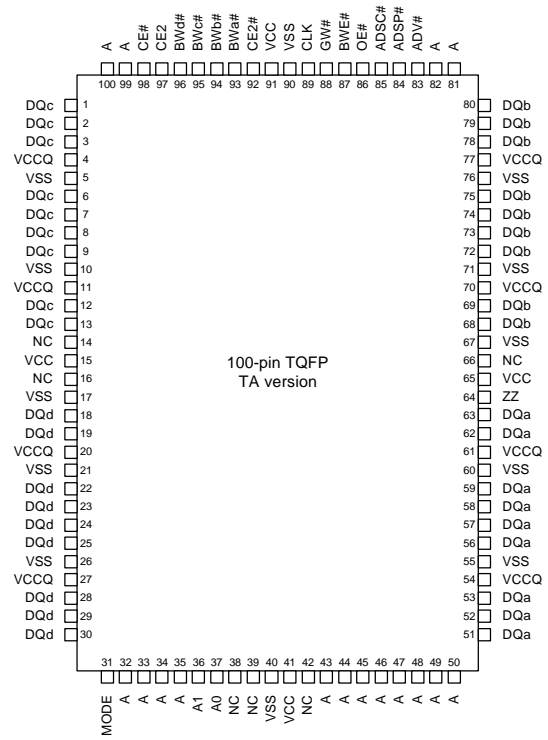

256Kx36, 119-Bump PBGA

	1	2	3	4	5	6	7
A	VCCQ	A	A	ADSP#	A	A	VCCQ
B	NC	CE2	A	ADSC#	A	A	NC
C	NC	A	A	VCC	A	A	NC
D	DQc	DQc	VSS	NC	VSS	DQb	DQb
E	DQc	DQc	VSS	CE#	VSS	DQb	DQb
F	VCCQ	DQc	VSS	OE#	VSS	DQb	VCCQ
G	DQc	DQc	BWc#	ADV#	BWb#	DQb	DQb
H	DQc	DQc	VSS	GW#	VSS	DQb	DQb
J	VCCQ	VCC	NC	VCC	NC	VCC	VCCQ
K	DQd	DQd	VSS	CLK	VSS	DQa	DQa
L	DQd	DQd	BWd#	NC	BWa#	DQa	DQa
M	VCCQ	DQd	VSS	BWE#	VSS	DQa	VCCQ
N	DQd	DQd	VSS	A1	VSS	DQa	DQa
P	DQd	DQd	VSS	A0	VSS	DQa	DQa
R	NC	A	MODE	VCC	NC	A	NC
T	NC	NC	A	A	A	NC	ZZ
U	VCCQ	TMS	TDI	TCK	TDO	NC	VCCQ

TOP VIEW 119 LEAD BGA

256K X 36 PIN DESCRIPTIONS

X36 PBGA PIN S	X36 QFP PIN S	SYMBOL	TYPE	DESCRIPTION
4P 4N 2A, 3A, 5A, 6A, 3B, 5B, 6B, 2C, 3C, 5C, 6C, 2R, 6R, 3T, 4T, 5T	37 36 35, 34, 33, 32, 100, 99, 82, 81, 44, 45, 46, 47, 48, 49, 50 92 (T Version) 43 (TA Version)	A0 A1 A	Input- Synchronous	Addresses: These inputs are registered and must meet the setup and hold times around the rising edge of CLK. The burst counter generates internal addresses associated with A0 and A1, during burst cycle and wait cycle.
5L 5G 3G 3L	93 94 95 96	BWa# BWb# BWc# BWd#	Input- Synchronous	Byte Write: A byte write is LOW for a WRITE cycle and HIGH for a READ cycle. BWa# controls DQa. BWb# controls DQb. BWc# controls DQc. BWd# controls DQd. Data I/O are high impedance if either of these inputs are LOW, conditioned by BWE# being LOW.
4M	87	BWE#	Input- Synchronous	Write Enable: This active LOW input gates byte write operations and must meet the setup and hold times around the rising edge of CLK.
4H	88	GW#	Input- Synchronous	Global Write: This active LOW input allows a full 36-bit WRITE to occur independent of the BWE# and BWn# lines and must meet the setup and hold times around the rising edge of CLK.
4K	89	CLK	Input- Synchronous	Clock: This signal registers the addresses, data, chip enables, write control and burst control inputs on its rising edge. All synchronous inputs must meet setup and hold times around the clock's rising edge.
4E	98	CE#	Input- Synchronous	Chip Enable: This active LOW input is used to enable the device and to gate ADSP#.
2B	97	CE2	input- Synchronous	Chip enable: This active HIGH input is used to enable the device.
- (not available for PBGA)	92 (for TA Version only)	CE2#	input- Synchronous	Chip enable: This active LOW input is used to enable the device. Not available for B and T package versions.
4F	86	OE#	Input	Output Enable: This active LOW asynchronous input enables the data output drivers.
4G	83	ADV#	Input- Synchronous	Address Advance: This active LOW input is used to control the internal burst counter. A HIGH on this pin generates wait cycle (no address advance).
4A	84	ADSP#	Input- Synchronous	Address Status Processor: This active LOW input, along with CE# being LOW, causes a new external address to be registered and a READ cycle is initiated using the new address.
4B	85	ADSC#	Input- Synchronous	Address Status Controller: This active LOW input causes device to be de-selected or selected along with new external address to be registered. A READ or WRITE cycle is initiated depending upon write control inputs.
3R	31	MODE	Input- Static	Mode: This input selects the burst sequence. A LOW on this pin selects LINEAR BURST. A NC or HIGH on this pin selects INTERLEAVED BURST.
7T	64	ZZ	Input- Asynchronous	Snooze: This active HIGH input puts the device in low power consumption standby mode. For normal operation, this input has to be either LOW or NC (No Connect).
(a) 6P, 7P, 7N, 6N, 6M, 6L, 7L, 6K, 7K, (b) 7H, 6H, 7G, 6G, 6F, 6E, 7E, 7D, 6D, (c) 2D, 1D, 1E, 2E, 2F, 1G, 2G, 1H, 2H, (d) 1K, 2K, 1L, 2L, 2M, 1N, 2N, 1P, 2P	(a) 51, 52, 53, 56, 57, 58, 59, 62, 63 (b) 68, 69, 72, 73, 74, 75, 78, 79, 80 (c) 1, 2, 3, 6, 7, 8, 9, 12, 13 (d) 18, 19, 22, 23, 24, 25, 28, 29, 30	DQa DQb DQc DQd	Input/ Output	Data Inputs/Outputs: First Byte is DQa. Second Byte is DQb. Third Byte is DQc. Fourth Byte is DQd. Input data must meet setup and hold times around the rising edge of CLK.
2U 3U 4U	38 39 43 for B and T version	TMS TDI TCK	Input	IEEE 1149.1 test inputs. LVTTTL-level inputs. Not available for TA package version.
5U	42 for B and T version	TDO	Output	IEEE 1149.1 test output. LVTTTL-level output. Not available for TA package version.
4C, 2J, 4J, 6J, 4R	15, 41, 65, 91	VCC	Supply	Core power Supply: +3.3V -5% and +10%
3D, 5D, 3E, 5E, 3F, 5F, 3H, 5H, 3K, 5K, 3M, 5M, 3N, 5N, 3P, 5P	5, 10, 17, 21, 26, 40, 55, 60, 67, 71, 76, 90	VSS	Ground	Ground: GND.
1A, 7A, 1F, 7F, 1J, 7J, 1M, 7M, 1U, 7U	4, 11, 20, 27, 54, 61, 70, 77	VCCQ	I/O Supply	Output Buffer Supply: +2.5V or +3.3V.
1B, 7B, 1C, 7C, 4D, 3J, 5J, 4L, 1R, 5R, 7R, 1T, 2T, 6T, 6U	14, 16, 66 38, 39, 42 for TA Version	NC	-	No Connect: These signals are not internally connected. User can leave it floating or connect it to VCC or VSS.

512K X 18 PIN DESCRIPTION S

X18 PBGA PIN S	X18 QFP PIN S	SYMBOL	TYPE	DESCRIPTION
4P 4N 2A, 3A, 5A, 6A, 3B, 5B, 6B, 2C, 3C, 5C, 6C, 2R, 6R, 2T, 3T, 5T, 6T	37 36 35, 34, 33, 32, 100, 99, 82, 81, 80, 48, 47, 46, 45, 44, 49, 50 92 (T Version) 43 (TA Version)	A0 A1 A	Input- Synchronous	Addresses: These inputs are registered and must meet the setup and hold times around the rising edge of CLK. The burst counter generates internal addresses associated with A0 and A1, during burst cycle and wait cycle.
5L 3G	93 94	BWa# BWb#	Input- Synchronous	Byte Write Enables: A byte write enable is LOW for a WRITE cycle and HIGH for a READ cycle. BWa# controls DQa. BWb# controls DQb. Data I/O are high impedance if either of these inputs are LOW, conditioned by BWE# being LOW.
4M	87	BWE#	Input- Synchronous	Write Enable: This active LOW input gates byte write operations and must meet the setup and hold times around the rising edge of CLK.
4H	88	GW#	Input- Synchronous	Global Write: This active LOW input allows a full 18-bit WRITE to occur independent of the BWE# and WEn# lines and must meet the setup and hold times around the rising edge of CLK.
4K	89	CLK	Input- Synchronous	Clock: This signal registers the addresses, data, chip enables, write control and burst control inputs on its rising edge. All synchronous inputs must meet setup and hold times around the clock's rising edge.
4E	98	CE#	Input- Synchronous	Chip Enable: This active LOW input is used to enable the device and to gate ADSP#.
2B	97	CE2	input- Synchronous	Chip enable: This active HIGH input is used to enable the device.
- (not available for PBGA)	92 (for TA Version only)	CE2#	input- Synchronous	Chip enable: This active LOW input is used to enable the device. Not available for B and T package versions.
4F	86	OE#	Input	Output Enable: This active LOW asynchronous input enables the data output drivers.
4G	83	ADV#	Input- Synchronous	Address Advance: This active LOW input is used to control the internal burst counter. A HIGH on this pin generates wait cycle (no address advance).
4A	84	ADSP#	Input- Synchronous	Address Status Processor: This active LOW input, along with CE# being LOW, causes a new external address to be registered and a READ cycle is initiated using the new address.
4B	85	ADSC#	Input- Synchronous	Address Status Controller: This active LOW input causes device to be de-selected or selected along with new external address to be registered. A READ or WRITE cycle is initiated depending upon write control inputs.
3R	31	MODE	Input- Static	Mode: This input selects the burst sequence. A LOW on this pin selects LINEAR BURST. A NC or HIGH on this pin selects INTERLEAVED BURST.
7T	64	ZZ	Input- Asynchronou s	Snooze: This active HIGH input puts the device in low power consumption standby mode. For normal operation, this input has to be either LOW or NC (No Connect).
(a) 6D, 7E, 6F, 7G, 6H, 7K, 6L, 6N, 7P (b) 1D, 2E, 2G, 1H, 2K, 1L, 2M, 1N, 2P	(a) 58, 59, 62, 63, 68, 69, 72, 73, 74 (b) 8, 9, 12, 13, 18, 19, 22, 23, 24	DQa DQb	Input/ Output	Data Inputs/Outputs: Low Byte is DQa. High Byte is DQb. Input data must meet setup and hold times around the rising edge of CLK .
2U 3U 4U	38 39 43 for B and T version	TMS TDI TCK	Input	IEEE 1149.1 test inputs. LVTTTL-level inputs. Not available for TA package version.
5U	42 for B and T version	TDO	Output	IEEE 1149.1 test output. LVTTTL-level output. Not available for TA package version.
4C, 2J, 4J, 6J, 4R	15, 41, 65, 91	VCC	Supply	Core power Supply: +3.3V -5% and +10%
3D, 5D, 3E, 5E, 3F, 5F, 5G, 3H, 5H, 3K, 5K, 3L, 3M, 5M, 3N, 5N, 3P, 5P	5, 10, 17, 21, 26, 40, 55, 60, 67, 71, 76, 90	VSS	Ground	Ground: GND.
1A, 7A, 1F, 7F, 1J, 7J, 1M, 7M, 1U, 7U	4, 11, 20, 27, 54, 61, 70, 77	VCCQ	I/O Supply	Output Buffer Supply: +2.5V or +3.3V.
1B, 7B, 1C, 7C, 2D, 4D, 7D, 1E, 6E, 2F, 1G, 6G, 2H, 7H, 3J, 5J, 1K, 6K, 2L, 4L, 7L, 6M, 2N, 7N, 1P, 6P, 1R, 5R, 7R, 1T, 4T, 6U	1-3, 6, 7, 14, 16, 25, 28-30, 51-53, 56, 57, 66, 75, 78, 79, 80, 95, 96 38, 39, 42 for TA Version	NC	-	No Connect: These signals are not internally connected. User can leave it floating or connect it to VCC or VSS.

BURST ADDRESS TABLE (MODE = NC/VCC)

First Address (external)	Second Address (internal)	Third Address (internal)	Fourth Address (internal)
A...A00	A...A01	A...A10	A...A11
A...A01	A...A00	A...A11	A...A10
A...A10	A...A11	A...A00	A...A01
A...A11	A...A10	A...A01	A...A00

BURST ADDRESS TABLE (MODE = GND)

First Address (external)	Second Address (internal)	Third Address (internal)	Fourth Address (internal)
A...A00	A...A01	A...A10	A...A11
A...A01	A...A10	A...A11	A...A00
A...A10	A...A11	A...A00	A...A01
A...A11	A...A00	A...A01	A...A10

TRUTH TABLE

OPERATION	ADDRESS USED	CE#	CE2#	CE2	ADSP#	ADSC#	ADV#	WRITE#	OE#	CLK	DQ
Deselected Cycle, Power Down	None	H	X	X	X	L	X	X	X	L-H	High-Z
Deselected Cycle, Power Down	None	L	X	L	L	X	X	X	X	L-H	High-Z
Deselected Cycle, Power Down	None	L	H	X	L	X	X	X	X	L-H	High-Z
Deselected Cycle, Power Down	None	L	X	L	H	L	X	X	X	L-H	High-Z
Deselected Cycle, Power Down	None	L	H	X	H	L	X	X	X	L-H	High-Z
READ Cycle, Begin Burst	External	L	L	H	L	X	X	X	L	L-H	Q
READ Cycle, Begin Burst	External	L	L	H	L	X	X	X	H	L-H	High-Z
WRITE Cycle, Begin Burst	External	L	L	H	H	L	X	L	X	L-H	D
READ Cycle, Begin Burst	External	L	L	H	H	L	X	H	L	L-H	Q
READ Cycle, Begin Burst	External	L	L	H	H	L	X	H	H	L-H	High-Z
READ Cycle, Continue Burst	Next	X	X	X	H	H	L	H	L	L-H	Q
READ Cycle, Continue Burst	Next	X	X	X	H	H	L	H	H	L-H	High-Z
READ Cycle, Continue Burst	Next	H	X	X	X	H	L	H	L	L-H	Q
READ Cycle, Continue Burst	Next	H	X	X	X	H	L	H	H	L-H	High-Z
WRITE Cycle, Continue Burst	Next	X	X	X	H	H	L	L	X	L-H	D
WRITE Cycle, Continue Burst	Next	H	X	X	X	H	L	L	X	L-H	D
READ Cycle, Suspend Burst	Current	X	X	X	H	H	H	H	L	L-H	Q
READ Cycle, Suspend Burst	Current	X	X	X	H	H	H	H	H	L-H	High-Z
READ Cycle, Suspend Burst	Current	H	X	X	X	H	H	H	L	L-H	Q
READ Cycle, Suspend Burst	Current	H	X	X	X	H	H	H	H	L-H	High-Z
WRITE Cycle, Suspend Burst	Current	X	X	X	H	H	H	L	X	L-H	D
WRITE Cycle, Suspend Burst	Current	H	X	X	X	H	H	L	X	L-H	D

- Note:
- X means "don't care." H means logic HIGH. L means logic LOW.
For X36 product, WRITE# = L means [BWE# + BWA#*BWb#*BWC#*BWD#]*GW# equals LOW. WRITE# = H means [BWE# + BWA#*BWb#*BWC#*BWD#]*GW# equals HIGH.
For X18 product, WRITE# = L means [BWE# + BWA#*BWb#]*GW# equals LOW. WRITE# = H means [BWE# + BWA#*BWb#]*GW# equals HIGH.
 - BWA# enables write to DQa. BWb# enables write to DQb. BWC# enables write to DQc. BWD# enables write to DQd
 - All inputs except OE# must meet setup and hold times around the rising edge (LOW to HIGH) of CLK
 - Suspending burst generates wait cycle
 - For a write operation following a read operation, OE# must be HIGH before the input data required setup time plus High-Z time for OE# and staying HIGH throughout the input data hold time
 - This device contains circuitry that will ensure the outputs will be in High-Z during power-up
 - ADSP# LOW along with chip being selected always initiates a READ cycle at the L-H edge of CLK. A WRITE cycle can be performed by setting WRITE# LOW for the CLK L-H edge of the subsequent wait cycle. Refer to WRITE timing diagram for clarification.

PARTIAL TRUTH TABLE FOR READ/WRITE

FUNCTION	GW#	BWE#	BWA#	BWb#	BWC#	BWD#
READ	H	H	X	X	X	X
READ	H	L	H	H	H	H
WRITE one byte	H	L	L	H	H	H
WRITE all bytes	H	L	L	L	L	L
WRITE all bytes	L	X	X	X	X	X

Note: For X18 product, There are only BWA# and BWb#.

ABSOLUTE MAXIMUM RATINGS *

Voltage on VCC Supply Relative to VSS.....	-0.5V to +4.6V
V _{IN}	-0.5V to VCC+0.5V
Storage Temperature (plastic)	-55°C to +150°
Junction Temperature	+150°
Power Dissipation	1.0W
Short Circuit Output Current	50mA

*Stresses greater than those listed under “Absolute Maximum Ratings” may cause permanent damage to the device. This is a stress rating only and functional operation of the device at these or any other conditions above those indicated in the operational sections of this specification is not implied. Exposure to absolute maximum rating conditions for extended periods may affect reliability

DC ELECTRICAL CHARACTERISTICS AND RECOMMENDED OPERATING CONDITIONS

(0°C ≤ T_a ≤ 70°C; VCC = 3.3V -5% and +10% unless otherwise noted)

DESCRIPTION	CONDITIONS	SYMBOL	MIN	MAX	UNITS	NOTES
Input High (Logic 1) Voltage	Data Inputs (DQx)	V _{IHD}	2.0	VCC+0.3	V	1,2
	All Other Inputs	V _{IH}	2.0	4.6	V	1,2
Input Low (Logic 0) Voltage		V _{IL}	-0.5	0.8	V	1, 2
Input Leakage Current	0V ≤ V _{IN} ≤ VCC	I _{L1}	-5	5	uA	
MODE and ZZ Input Leakage Current	0V ≤ V _{IN} ≤ VCC	I _{L1}	-30	30	uA	6
Output Leakage Current	Output(s) disabled, 0V ≤ V _{OUT} ≤ VCC	I _{LO}	-5	5	uA	
Output High Voltage	I _{OH} = -5.0mA	V _{OH}	2.4		V	1
Output Low Voltage	I _{OL} = 8.0mA	V _{OL}		0.4	V	1
Supply Voltage		VCC	3.135	3.6	V	1
I/O Supply Voltage (3.3V)		VCCQ	3.135	VCC	V	1
I/O Supply Voltage (2.5V)		VCCQ	2.375	VCC	V	1

DESCRIPTION	CONDITIONS	SYM	TYP	-6	-6.5	-7	-8	UNITS	NOTES
Power Supply Current: Operating	Device selected; all inputs ≤ V _{IL} or ≥ V _{IH} ; cycle time ≥ 1KC MIN; VCC = MAX; outputs open	I _{CC}	150	400	360	320	270	mA	3, 12, 13
CMOS Standby	Device deselected; VCC = MAX; all inputs ≤ VSS +0.2 or ≥ VCC -0.2; all inputs static; CLK frequency = 0	I _{SB2}	5	10	10	10	10	mA	12,13
TTL Standby	Device deselected; all inputs ≤ V _{IL} or ≥ V _{IH} ; all inputs static; VCC = MAX; CLK frequency = 0	I _{SB3}	15	30	30	30	30	mA	12,13
Clock Running	Device deselected; all inputs ≤ V _{IL} or ≥ V _{IH} ; VCC = MAX; CLK cycle time ≥ 1KC MIN	I _{SB4}	40	90	80	70	60	mA	12,13

THERMAL CONSIDERATION

DESCRIPTION	CONDITIONS	SYMBOL	TQFP TYP	UNITS	NOTES
Thermal Resistance - Junction to Ambient	Still air, soldered on 4.25 x 1.125 inch 4-layer PCB	θ _{JA}	25	°C/W	
Thermal Resistance - Junction to Case		θ _{JC}	9	°C/W	

AC ELECTRICAL CHARACTERISTICS

(Note 5) ($0^{\circ}\text{C} \leq T_A \leq 70^{\circ}\text{C}$; $V_{CC} = 3.3\text{V} -5\%$ and $+10\%$)

DESCRIPTION	SYM	- 6 150MHz		- 6.5 133MHz		- 7 117MHz		- 8 100MHz		UNITS	NOTES		
		MIN	MAX	MIN	MAX	MIN	MAX	MIN	MAX				
Clock													
Clock cycle time	t_{KC}		6.7		7.5		8.5		10		ns		
Clock HIGH time	t_{KH}		2.5		2.5		3.0		3.5		ns		
Clock LOW time	t_{KL}		2.5		2.5		3.0		3.5		ns		
Output Times													
Clock to output valid	t_{KQ}	$V_{CCQ} = 3.3\text{V}$		6.0		6.5		7.0		8.0		ns	
		$V_{CCQ} = 2.5\text{V}$		6.5		7.0		7.5		9.0		ns	
Clock to output invalid	t_{KQX}		2		2		2		2		ns		
Clock to output in Low-Z	t_{KQLZ}		0		0		0		0		ns	4, 6, 7	
Clock to output in High-Z	t_{KQHZ}		2	3.5	2	3.5	2	3.5	2	3.5	ns	4, 6, 7	
OE to output valid	t_{OEQ}	$V_{CCQ} = 3.3\text{V}$		3.5		3.5		3.5		4.0		ns	9
		$V_{CCQ} = 2.5\text{V}$		4.5		4.5		4.5		5.0			
OE to output in Low-Z	t_{OELZ}		0		0		0		0		ns	4, 6, 7	
OE to output in High-Z	t_{OEHZ}			3.5		3.5		3.5		3.5	ns	4, 6, 7	
Setup Times													
Address, Controls and Data In	t_S		1.5		1.5		1.8		2.0		ns	10	
Hold Times													
Address, Controls and Data In	t_H		0.5		0.5		0.5		0.5		ns	10	

CAPACITANCE

DESCRIPTION	CONDITIONS	SYMBOL	TYP	MAX	UNITS	NOTES
Input Capacitance	$T_A = 25^{\circ}\text{C}$; $f = 1\text{ MHz}$ $V_{CC} = 3.3\text{V}$	C_I	5	7	pF	4
Input/Output Capacitance (DQ)		C_O	7	8	pF	4

TYPICAL OUTPUT BUFFER CHARACTERISTICS

OUTPUT HIGH VOLTAGE	PULL-UP CURRENT		OUTPUT LOW VOLTAGE	PULL-DOWN CURRENT	
	$I_{OH}(\text{mA})$ Min	$I_{OH}(\text{mA})$ Max		$I_{OL}(\text{mA})$ Min	$I_{OL}(\text{mA})$ Max
$V_{OH}(\text{V})$			$V_{OL}(\text{V})$		
-0.5	-38	-105	-0.5	0	0
0	-38	-105	0	0	0
0.8	-38	-105	0.4	10	20
1.25	-26	-83	0.8	20	40
1.5	-20	-70	1.25	31	63
2.3	0	-30	1.6	40	80
2.7	0	-10	2.8	40	80
2.9	0	0	3.2	40	80
3.4	0	0	3.4	40	80

AC TEST CONDITIONS FOR 3.3V I/O

Input pulse levels	0V to 3.0V
Input rise and fall times	1ns
Output rise and fall times(max)	1.8ns
Input timing reference levels	1.5V
Output reference levels	1.5V
Output load	See Figures 1

AC TEST CONDITIONS FOR 2.5V I/O

Input pulse levels	0V to 2.5V
Input rise and fall times	1ns
Output rise and fall times(max)	1.8ns
Input timing reference levels	1.25V
Output reference levels	1.25V
Output load	See Figures 1A

NOTES

- All voltages referenced to VSS (GND)
- Overshoot: $V_{IH} \leq +6.0V$ for $t \leq {}^tKC / 2$.
Undershoot: $V_{IL} \leq -2.0V$ for $t \leq {}^tKC / 2$
- I_{cc} is given with no output current. I_{cc} increases with greater output loading and faster cycle times
- This parameter is sampled.
- Test conditions as specified with the output loading as shown in Fig. 1 unless otherwise noted
- Output loading is specified with $CL=5pF$ as in Fig. 2
- At any given temperature and voltage condition, tKQHZ is less than tKQLZ and tOEHZ is less than tOELZ .
- A READ cycle is defined by byte write enables all HIGH or ADSP# LOW along with chip enables being active for the required setup and hold times. A WRITE cycle is defined by at one byte or all byte WRITE per READ/WRITE TRUTH TABLE.
- OE# is a "don't care" when a byte write enable is sampled LOW.

OUTPUT LOADS FOR 3.3V I/O

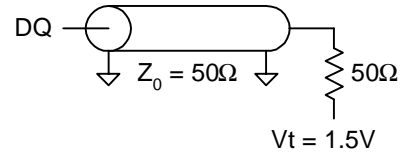

Fig. 1 OUTPUT LOAD EQUIVALENT

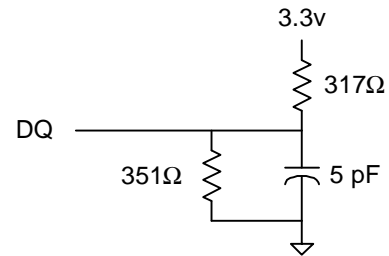

Fig. 2 OUTPUT LOAD EQUIVALENT

OUTPUT LOADS FOR 2.5V I/O

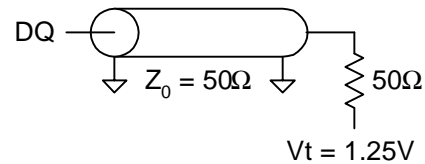
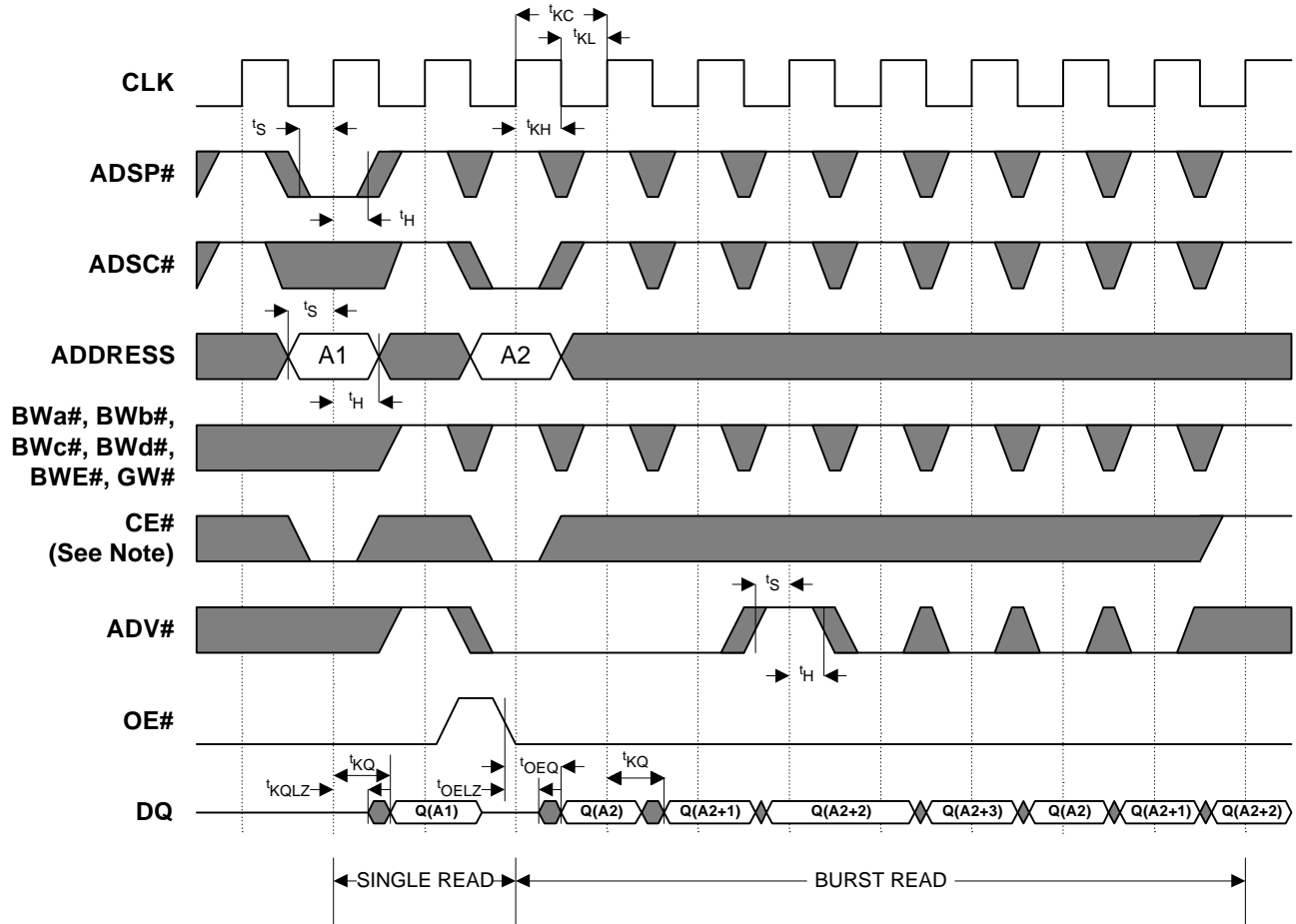

Fig. 1A OUTPUT LOAD EQUIVALENT

- This is a synchronous device. All synchronous inputs must meet specified setup and hold time, except for "don't care" as defined in the truth table.
- AC I/O curves are available upon request
- "Device Deselected" means the device is in POWER -DOWN mode as defined in the truth table. "Device Selected" means the device is active.
- Typical values are measured at 3.3V, 25°C and 20ns cycle time.
- MODE pin has an internal pull-up and ZZ pin has an internal pull-down. These two pins exhibit an input leakage current of $\pm 30 \mu A$.
- Capacitance derating applies to capacitance different from the load capacitance shown in Fig. 1 or Fig. 1A.

READ TIMING



Note: CE# active in this timing diagram means that all chip enables CE#, CE2#, and CE2 are active. CE2# is only available for TA package version.

For X18 product, there are only BwA# and BwB# for byte write control.

WRITE TIMING

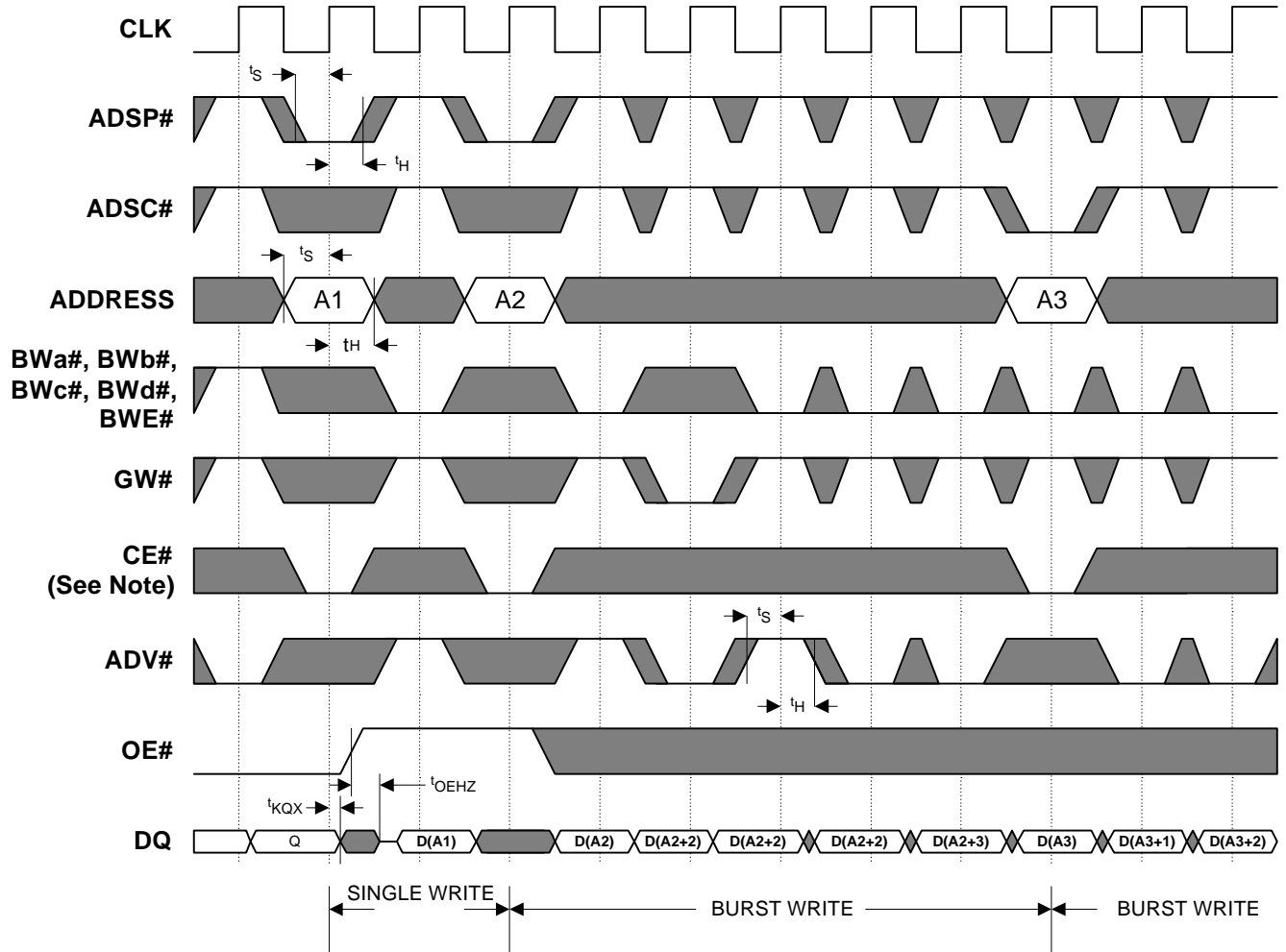

Note: CE# active in this timing diagram means that all chip enables CE#, CE2#, and CE2 are active. CE2# is only available for TA package version.

For X18 product, there are only BWA# and BWb# for byte write control.

READ/WRITE TIMING

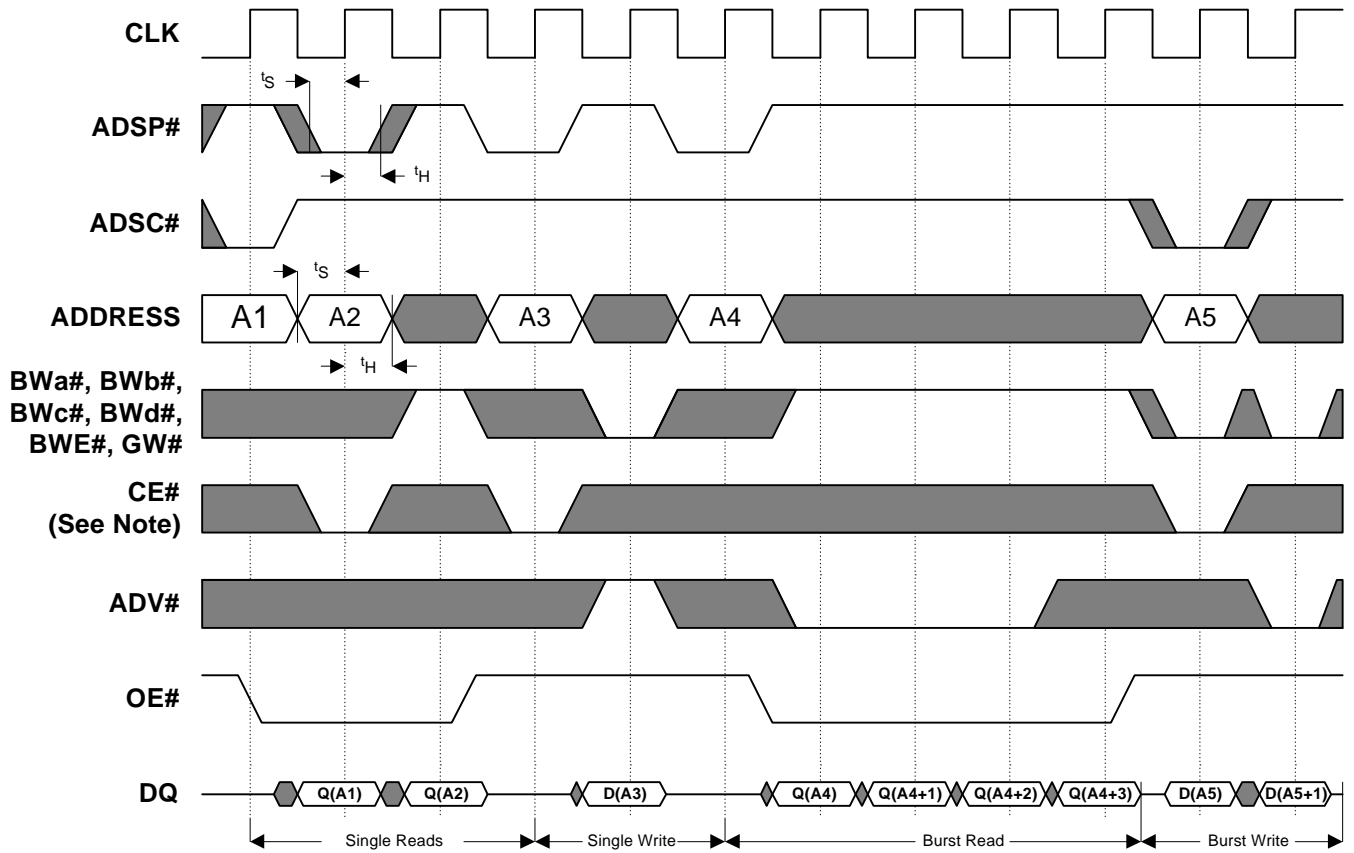

Note: CE# active in this timing diagram means that all chip enables CE#, CE2#, and CE2 are active. CE2# is only available for TA package version.

For X18 product, there are only BWa# and BWb# for byte write control.

IEEE 1149.1 SERIAL BOUNDARY SCAN (JTAG)

OVERVIEW

This device incorporates a serial boundary scan access port (TAP). This port is designed to operate in a manner consistent with IEEE Standard 1149.1-1990 (commonly referred to as JTAG), but does not implement all of the functions required for IEEE 1149.1 compliance. Certain functions have been modified or eliminated because their implementation places extra delays in the critical speed path of the device. Nevertheless, the device supports the standard TAP controller architecture (the TAP controller is the state machine that controls the TAPs operation) and can be expected to function in a manner that does not conflict with the operation of devices with IEEE Standard 1149.1 compliant TAPs. The TAP operates using LVTTTL/LVCMOS logic level signaling.

DISABLING THE JTAG FEATURE

It is possible to use this device without using the JTAG feature. To disable the TAP controller without interfering with normal operation of the device, TCK should be tied LOW (VSS) to prevent clocking the device. TDI and TMS are internally pulled up and may be unconnected. They may alternately be pulled up to VCC through a resistor. TDO should be left unconnected. Upon power-up the device will come up in a reset state which will not interfere with the operation of the device.

TEST ACCESS PORT (TAP)

TCK - TEST CLOCK (INPUT)

Clocks all TAP events. All inputs are captured on the rising edge of TCK and all outputs propagate from the falling edge of TCK.

TMS - TEST MODE SELECT (INPUT)

The TMS input is sampled on the rising edge of TCK. This is the command input for the TAP controller state machine. It is allowable to leave this pin unconnected if the TAP is not used. The pin is pulled up internally, resulting in a logic HIGH level.

TDI - TEST DATA IN (INPUT)

The TDI input is sampled on the rising edge of TCK. This is the input side of the serial registers placed between TDI and TDO. The register placed between TDI and TDO is

determined by the state of the TAP controller state machine and the instruction that is currently loaded in the TAP instruction register (refer to Figure 3, TAP Controller State Diagram). It is allowable to leave this pin unconnected if it is not used in an application. The pin is pulled up internally, resulting in a logic HIGH level. TDI is connected to the most significant bit (MSB) of any register. (See Figure 4.)

TDO - TEST DATA OUT (OUTPUT)

The TDO output pin is used to serially clock data-out from the registers. The output that is active depending on the state of the TAP state machine (refer to Figure 3, TAP Controller State Diagram). Output changes in response to the falling edge of TCK. This is the output side of the serial registers placed between TDI and TDO. TDO is connected to the least significant bit (LSB) of any register. (See Figure 4.)

PERFORMING A TAP RESET

The TAP circuitry does not have a reset pin (TRST#, which is optional in the IEEE 1149.1 specification). A RESET can be performed for the TAP controller by forcing TMS HIGH (VCC) for five rising edges of TCK and preloads the instruction register with the IDCODE command. This type of reset does not affect the operation of the system logic. The reset affects test logic only.

At power-up, the TAP is reset internally to ensure that TDO is in a High-Z state.

TEST ACCESS PORT (TAP) REGISTERS

OVERVIEW

The various TAP registers are selected (one at a time) via the sequences of ones and zeros input to the TMS pin as the TCK is strobed. Each of the TAPs registers are serial shift registers that capture serial input data on the rising edge of TCK and push serial data out on subsequent falling edge of TCK. When a register is selected, it is connected between the TDI and TDO pins.

INSTRUCTION REGISTER

The instruction register holds the instructions that are executed by the TAP controller when it is moved into the run test/idle or the various data register states. The instructions are three bits long. The register can be loaded when it is placed between the TDI and TDO pins. The parallel outputs of the instruction register are automatically preloaded with the IDCODE instruction upon power-up or whenever the

controller is placed in the test-logic reset state. When the TAP controller is in the Capture-IR state, the two least significant bits of the serial instruction register are loaded with a binary “01” pattern to allow for fault isolation of the board-level serial test data path.

BYPASS REGISTER

The bypass register is a single-bit register that can be placed between TDI and TDO. It allows serial test data to be passed through the device TAP to another device in the scan chain with minimum delay. The bypass register is set LOW (VSS) when the BYPASS instruction is executed.

BOUNDARY SCAN REGISTER

The Boundary scan register is connected to all the input and bidirectional I/O pins (not counting the TAP pins) on the device. This also includes a number of NC pins that are reserved for future needs. There are a total of 70 bits for x36 device and 51 bits for x18 device. The boundary scan register, under the control of the TAP controller, is loaded with the contents of the device I/O ring when the controller is in Capture-DR state and then is placed between the TDI and TDO pins when the controller is moved to Shift-DR state. The EXTEST, SAMPLE/PRELOAD and SAMPLE-Z instructions can be used to capture the contents of the I/O ring.

The Boundary Scan Order table describes the order in which the bits are connected. The first column defines the bit's position in the boundary scan register. The MSB of the register is connected to TDI, and LSB is connected to TDO. The second column is the signal name and the third column is the bump number. The third column is the TQFP pin number and the fourth column is the PBGA bump number.

IDENTIFICATION (ID) REGISTER

The ID Register is a 32-bit register that is loaded with a device and vendor specific 32-bit code when the controller is put in Capture-DR state with the IDCODE command loaded in the instruction register. The register is then placed between the TDI and TDO pins when the controller is moved into Shift-DR state. Bit 0 in the register is the LSB and the first to reach TDO when shifting begins. The code is loaded from a 32-bit on-chip ROM. It describes various attributes of the device as described in the Identification Register Definitions table.

TAP CONTROLLER INSTRUCTION SET

OVERVIEW

There are two classes of instructions defined in the IEEE Standard 1149.1-1990; the standard (public) instructions and device specific (private) instructions. Some public instructions are mandatory for IEEE 1149.1 compliance. Optional public instructions must be implemented in prescribed ways.

Although the TAP controller in this device follows the IEEE 1149.1 conventions, it is not IEEE 1149.1 compliant because some of the mandatory instructions are not fully implemented. The TAP on this device may be used to monitor all input and I/O pads, but can not be used to load address, data, or control signals into the device or to preload the I/O buffers. In other words, the device will not perform IEEE 1149.1 EXTEST, INTEST, or the preload portion of the SAMPLE/PRELOAD command.

When the TAP controller is placed in Capture-IR state, the two least significant bits of the instruction register are loaded with 01. When the controller is moved to the Shift-IR state the instruction is serially loaded through the TDI input (while the previous contents are shifted out at TDO). For all instructions, the TAP executes newly loaded instructions only when the controller is moved to Update-IR state. The TAP instruction sets for this device are listed in the following tables.

EXTEST

EXTEST is an IEEE 1149.1 mandatory public instruction. It is to be executed whenever the instruction register is loaded with all 0s. EXTEST is not implemented in this device.

The TAP controller does not recognize an all-0 instruction. When an EXTEST instruction is loaded into the instruction register, the device responds as if a SAMPLE/PRELOAD instruction has been loaded. There is one difference between two instructions. Unlike SAMPLE/PRELOAD instruction, EXTEST places the device outputs in a High-Z state.

IDCODE

The IDCODE instruction causes a vendor-specific, 32-bit code to be loaded into the ID register when the controller is in Capture-DR mode and places the ID register between the TDI and TDO pins in Shift-DR mode. The IDCODE instruction is the default instruction loaded in the instruction upon power-up and at any time the TAP controller is placed in the test-logic reset state.

SAMPLE-Z

If the High-Z instruction is loaded in the instruction register, all output pins are forced to a High-Z state and the boundary scan register is connected between TDI and TDO pins when the TAP controller is in a Shift-DR state.

SAMPLE/PRELOAD

SAMPLE/PRELOAD is an IEEE 1149.1 mandatory instruction. The PRELOAD portion of the command is not implemented in this device, so the device TAP controller is not fully IEEE 1149.1-compliant.

When the SAMPLE/PRELOAD instruction is loaded in the instruction register and the TAP controller is in the Capture-DR state, a snap shot of the data in the device's input and I/O buffers is loaded into the boundary scan register. Because the device system clock(s) are independent from the TAP clock (TCK), it is possible for the TAP to attempt to capture the input and I/O ring contents while the buffers are in transition (i.e., in a metastable state). Although allowing the TAP to sample metastable inputs will not harm the device, repeatable results can not be expected. To guarantee that the boundary scan register will capture the correct value of a signal, the device input signals must be stabilized long enough to meet the TAP controller's capture setup plus hold time (tCS plus tCH). The device clock input(s) need not be paused for any other TAP operation except capturing the input and I/O ring contents into the boundary scan register.

Moving the controller to Shift-DR state then places the boundary scan register between the TDI and TDO pins. Because the PRELOAD portion of the command is not implemented in this device, moving the controller to the Update-DR state with the SAMPLE/PRELOAD instruction loaded in the instruction register has the same effect as the Pause-DR command.

BYPASS

When the BYPASS instruction is loaded in the instruction register and the TAP controller is in the Shift-DR state, the bypass register is placed between TDI and TDO. This allows the board level scan path to be shortened to facilitate testing of other devices in the scan path.

RESERVED

Do not use these instructions. They are reserved for future use.

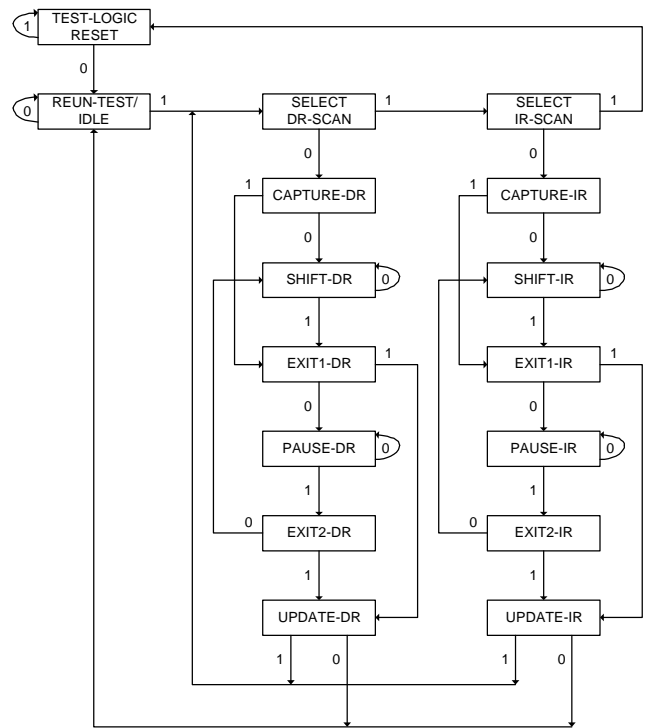

Note: The 0/1 next to each state represents the value of TMS at the rising edge of TCK.

Figure 3
TAP CONTROLLER STATE DIAGRAM

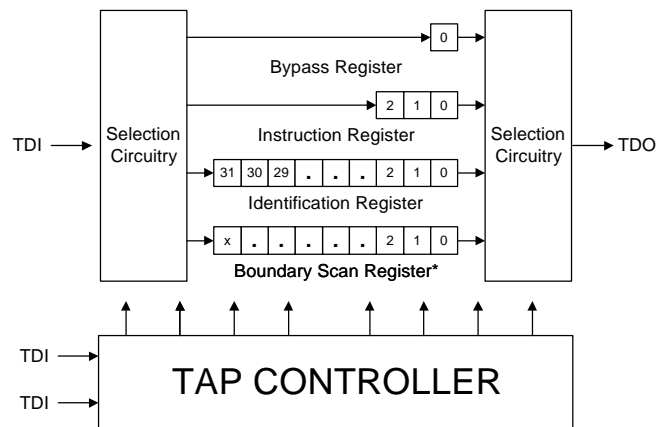

*X = 69 for the x36 configuration;
*X = 50 for the x18 configuration.

Figure 4
TAP CONTROLLER BLOCK DIAGRAM

TAP AC TEST CONDITIONS

Input pulse levels	VSS to 3.0V
Input rise and fall times	1.5ns
Input timing reference levels	1.5V
Output reference levels	1.5V
Output load termination supply voltage	1.5V

TAP OUTPUT LOADS

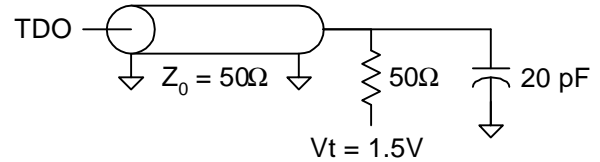

Figure 5
TAP AC OUTPUT LOAD EQUIVALENT

TAP DC ELECTRICAL CHARACTERISTICS AND OPERATING CONDITIONS

(20°C ≤ T_j ≤ 110°C; VCC = 3.3V -0.2V and +0.3V unless otherwise noted)

DESCRIPTION	CONDITIONS	SYMBOL	MIN	MAX	UNITS	NOTES
Input High (Logic 1) Voltage		V _{IH}	2.0	VCC + 0.3	V	1, 2
Input Low (Logic 0) Voltage		V _{IL}	-0.3	0.8	V	1, 2
Input Leakage Current	0V ≤ V _{IN} ≤ VCC	I _{LI}	-5.0	5.0	uA	
TMS and TDI input Leakage Current	0V ≤ V _{IN} ≤ VCC	I _{LI}	-30	30	uA	
Output Leakage Current	Output disabled, 0V ≤ V _{IN} ≤ VCCQ	I _{LO}	-5.0	5.0	uA	
LVC MOS Output Low Voltage	I _{OLC} = 100uA	V _{OLC}		0.2		1, 3
LVC MOS Output High Voltage	I _{OHC} = 100uA	V _{OHC}	VCC - 0.2			1, 3
LV TTL Output Low Voltage	I _{OLT} = 8.0mA	V _{OLT}		0.4		1
LV TTL Output High Voltage	I _{OHT} = 8.0mA	V _{OHT}	2.4			1

NOTE:

- All voltages referenced to VSS (GND)
- Overshoot: V_{IH}(AC) ≤ VCC + 1.5V for t ≤ t_{KHKH}/2.
 Undershoot: V_{IL}(AC) ≤ -0.5V for t ≤ t_{KHKH}/2
 Power-up: V_{IH} ≤ +3.6V and VCC ≤ 3.135V and VCCQ ≤ 1.4V for t ≤ 200ms
 During normal operation, VCCQ must not exceed VCC. Control input signals (such as GW#, ADSC#, etc.) may not have pulse widths less than t_{KHKL} (MIN).
- This parameter is sampled.

TAP TIMING

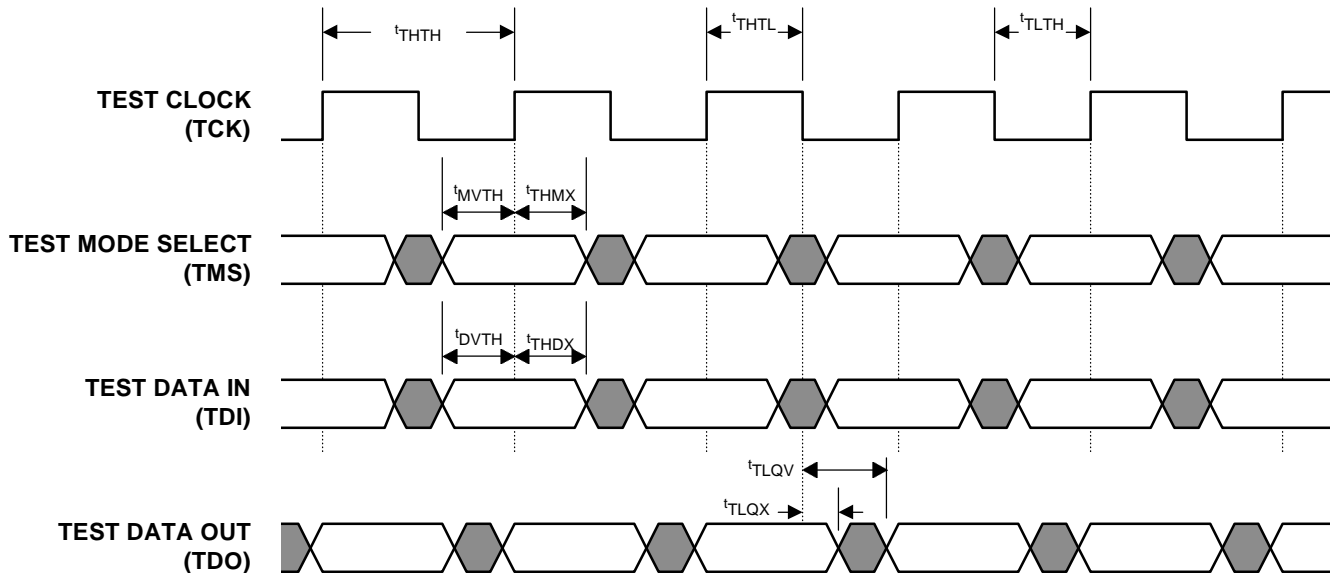

TAP AC ELECTRICAL CHARACTERISTICS

(Notes 1, 2) ($20^{\circ}\text{C} \leq T_j \leq 110^{\circ}\text{C}$; $V_{CC} = 3.3\text{V} - 0.2\text{V}$ and $+0.3\text{V}$)

DESCRIPTION	SYM	MIN	MAX	UNITS
Clock				
Clock cycle time	t_{THTH}	20		ns
Clock frequency	f_{TF}		50	MHz
Clock HIGH time	t_{THTL}	8		ns
Clock LOW time	t_{TLTH}	8		ns
Output Time s				
TCK LOW to TDO unknown	t_{TLQX}	0		ns
TCK LOW to TDO valid	t_{TLQV}		10	ns
TDI valid to TCK HIGH	t_{DVTH}	5		ns
TCK HIGH to TDI invalid	t_{THDX}	5		ns
Setup Time s				
TMS setup	t_{MVTH}	5		ns
Capture setup	t_{CS}	5		ns
Hold Time s				
TMS hold	t_{THMX}	5		ns
Capture hold	t_{CH}	5		ns

NOTE:

1. t_{CS} and t_{CH} refer to the setup and hold time requirements of latching data from the boundary scan register.
2. Test conditions are specified using the load in Figure 5.

IDENTIFICATION REGISTER DEFINITIONS

INSTRUCTION FIELD	256K x 36	512K x 18	DESCRIPTION
REVISION NUMBER (31:28)	XXXX	XXXX	Reserved for revision number.
DEVICE DEPTH (27:23)	00110	00111	Defines depth of 256K or 512K words.
DEVICE WIDTH (22:18)	00100	00011	Defines width of x36 or x18 bits.
RESERVED (17:12)	XXXXXX	XXXXXX	Reserved for future use.
GALVANTECH JEDEC ID CODE (11:1)	00011100100	00011100100	Allows unique identification of DEVICE vendor.
ID Register Presence Indicator (0)	1	1	Indicates the presence of an ID register.

SCAN REGISTER SIZES

REGISTER NAME	BIT SIZE (x36)	BIT SIZE (x18)
Instruction	3	3
Bypass	1	1
ID	32	32
Boundary Scan	70	51

INSTRUCTION CODES

Instruction	Code	Description
EXTEST	000	Captures I/O ring contents. Places the boundary scan register between TDI and TDO. Forces all device outputs to High-Z state. This instruction is not IEEE 1149.1-compliant.
IDCODE	001	Preloads ID register with vendor ID code and places it between TDI and TDO. This instruction does not affect device operations.
SAMPLE-Z	010	Captures I/O ring contents. Places the boundary scan register between TDI and TDO. Forces all device outputs to High-Z state.
RESERVED	011	Do not use these instructions; they are reserved for future use.
SAMPLE/PRE-LOAD	100	Captures I/O ring contents. Places the boundary scan register between TDI and TDO. This instruction does not affect device operations. This instruction does not implement IEEE 1149.1 PRELOAD function and is therefore not 1149.1-compliant.
RESERVED	101	Do not use these instructions; they are reserved for future use.
RESERVED	110	Do not use these instructions; they are reserved for future use.
BYPASS	111	Places the bypass register between TDI and TDO. This instruction does not affect device operations.

BOUNDARY SCAN ORDER (256K x 36)

BIT#	SINGAL NAME	TQFP	BUMP ID
1	A	44	2R
2	A	45	3T
3	A	46	4T
4	A	47	5T
5	A	48	6R
6	A	49	3B
7	A	50	5B
8	DQa	51	6P
9	DQa	52	7N
10	DQa	53	6M
11	DQa	56	7L
12	DQa	57	6K
13	DQa	58	7P
14	DQa	59	6N
15	DQa	62	6L
16	DQa	63	7K
17	ZZ	64	7T
18	DQb	68	6H
19	DQb	69	7G
20	DQb	72	6F
21	DQb	73	7E
22	DQb	74	6D
23	DQb	75	7H
24	DQb	78	6G
25	DQb	79	6E
26	DQb	80	7D
27	A	81	6A
28	A	82	5A
29	ADV#	83	4G
30	ADSP#	84	4A
31	ADSC#	85	4B
32	OE#	86	4F
33	BWE#	87	4M
34	GW#	88	4H
35	CLK	89	4K

36	A	92	6B
37	BWa#	93	5L
38	BWb#	94	5G
39	BWc#	95	3G
40	BWd#	96	3L
41	CE2	97	2B
42	CE#	98	4E
43	A	99	3A
44	A	100	2A
45	DQc	1	2D
46	DQc	2	1E
47	DQc	3	2F
48	DQc	6	1G
49	DQc	7	2H
50	DQc	8	1D
51	DQc	9	2E
52	DQc	12	2G
53	DQc	13	1H
54	NC	14	5R
55	DQd	18	2K
56	DQd	19	1L
57	DQd	22	2M
58	DQd	23	1N
59	DQd	24	2P
60	DQd	25	1K
61	DQd	28	2L
62	DQd	29	2N
63	DQd	30	1P
64	MODE	31	3R
65	A	32	2C
66	A	33	3C
67	A	34	5C
68	A	35	6C
69	A1	36	4N
70	A0	37	4P

BOUNDARY SCAN ORDER (512K x 18)

BIT#	SINGAL NAME	TQFP	BUMP ID
1	A	44	2R
2	A	45	2T
3	A	46	3T
4	A	47	5T
5	A	48	6R
6	A	49	3B
7	A	50	5B
8	DQa	58	7P
9	DQa	59	6N
10	DQa	62	6L
11	DQa	63	7K
12	ZZ	64	7T
13	DQa	68	6H
14	DQa	69	7G
15	DQa	72	6F
16	DQa	73	7E
17	DQa	74	6D
18	A	80	6T
19	A	81	6A
20	A	82	5A
21	ADV#	83	4G
22	ADSP#	84	4A
23	ADSC#	85	4B
24	OE#	86	4F
25	BWE#	87	4M
26	GW#	88	4H
27	CLK	89	4K
28	A	92	6B
29	BWa#	93	5L
30	BWb#	94	3G
31	CE2	97	2B
32	CE#	98	4E
33	A	99	3A
34	A	100	2A
35	DQb	8	1D

36	DQb	9	2E
37	DQb	12	2G
38	DQb	13	1H
39	NC	14	5R
40	DQb	18	2K
41	DQb	19	1L
42	DQb	22	2M
43	DQb	23	1N
44	DQb	24	2P
45	MODE	31	3R
46	A	32	2C
47	A	33	3C
48	A	34	5C
49	A	35	6C
50	A1	36	4N
51	A0	37	4P

100 Pin TQFP Package Dimension s

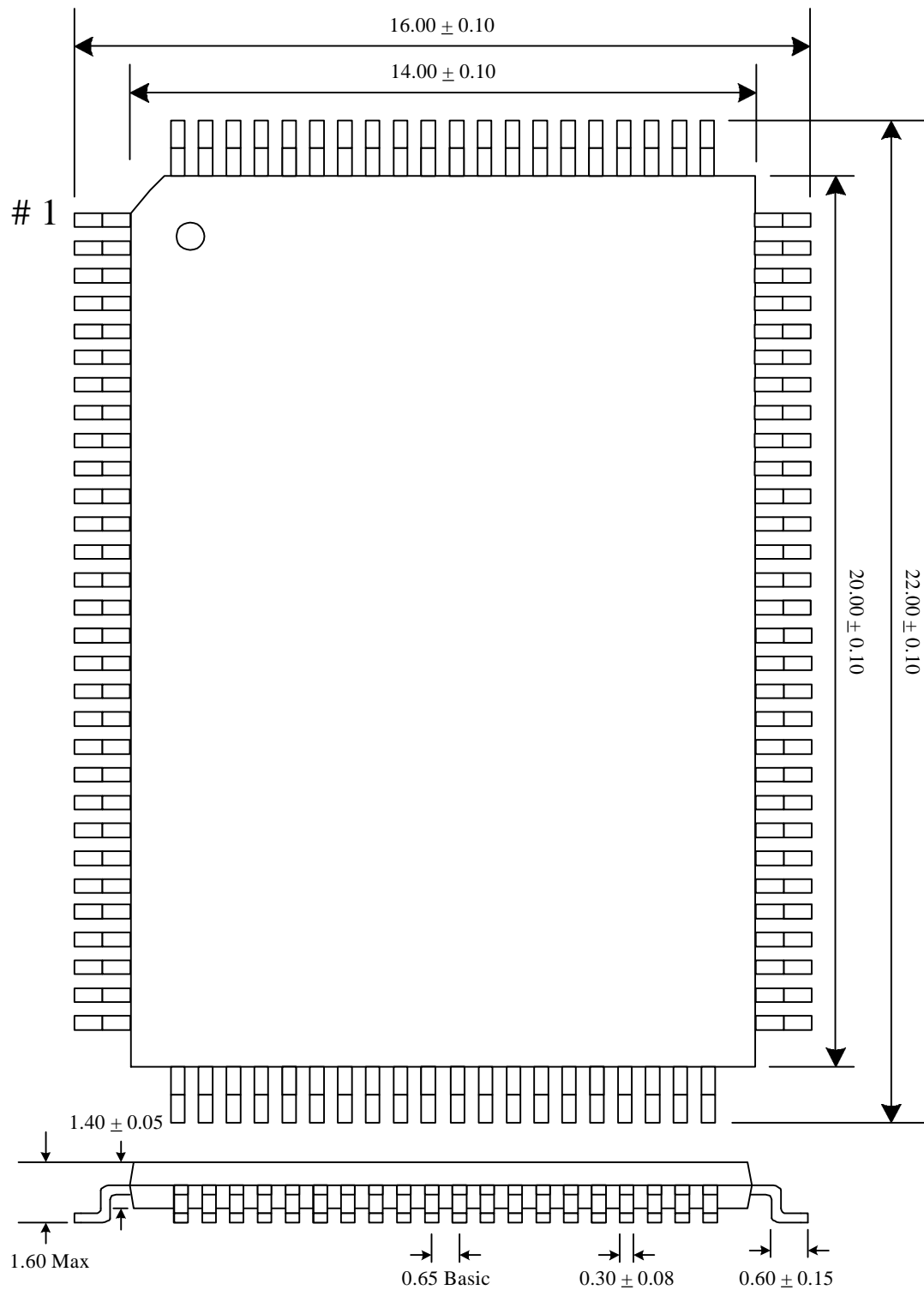

Note: All dimensions in Millimeters

7 x 17 (119-bump) PBGA Dimensions

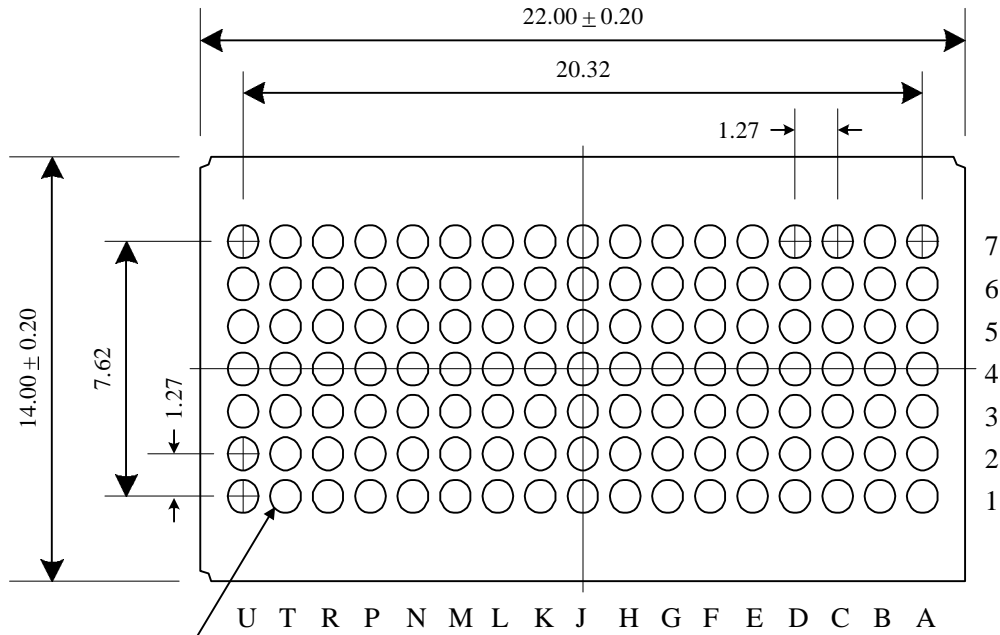

$\varnothing 0.75 \pm 0.15$ (119X)

BOTTOM VIEW

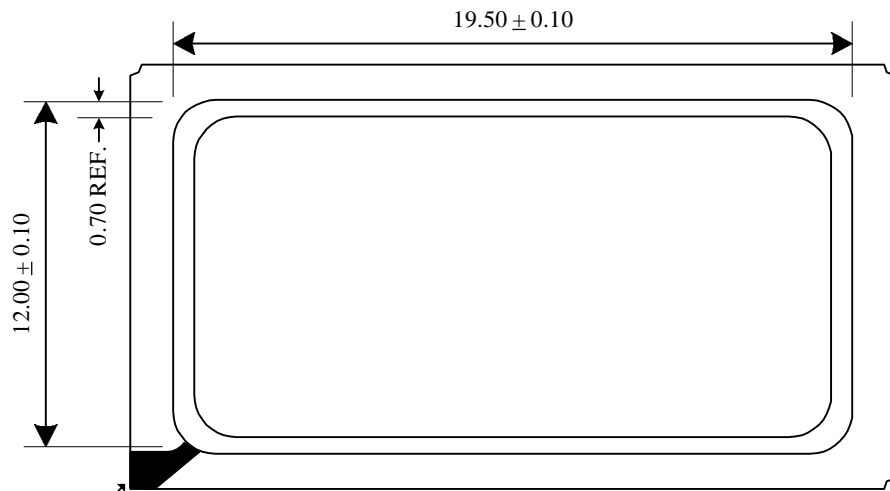

PIN 1A CORNER

TOP VIEW

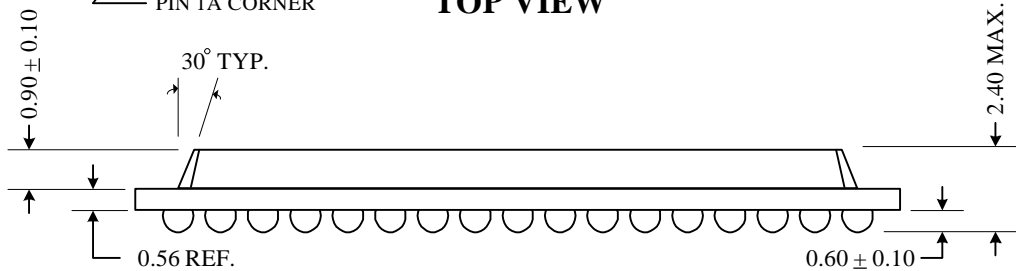

SIDE VIEW

Note: All dimensions in Millimeters

Ordering Information for 256K x 36

GVT 71256B36 X - X

Galvantech Prefix

Part Number for 256K x 36

Speed (6= 6.0ns access/6.7ns cycle
6.5 = 6.5ns access/7.5ns cycle
7 = 7.0ns access/8.5ns cycle
8 = 8.0ns access/10ns cycle)

Package (B = 119 BUMP PBGA,
T = 100 PIN TQFP, T Version)
TA= 100 PIN TQFP, TA Version)

Ordering Information for 512K x 18

GVT 71512B18 X - X

Galvantech Prefix

Part Number for 512K x 18

Speed (6= 6.0ns access/6.7ns cycle
6.5 = 6.5ns access/7.5ns cycle
7 = 7.0ns access/8.5ns cycle
8 = 8.0ns access/10ns cycle)

Package (B = 119 BUMP PBGA,
T = 100 PIN TQFP, T Version)
TA= 100 PIN TQFP, TA Version)