

GaAs MMIC SUB-HARMONICALLY PUMPED MIXER, 14 - 21 GHz

Typical Applications

The HMC258 is ideal for:

- Microwave Pt to Pt Radios
- VSAT
- SATCOM

Features

- Integrated LO Amplifier: 0dBm Drive
- Sub-Harmonically Pumped (x2) LO
- High 2LO/RF Isolation: 40 dB
- Small Size: 0.8mm x 1.1mm

Functional Diagram

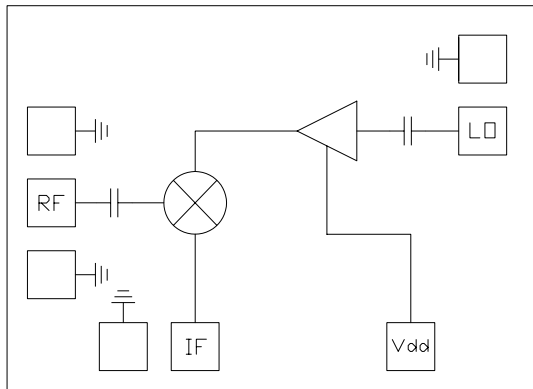

General Description

The HMC258 chip is a compact sub-harmonically pumped (x2) single ended MMIC mixer with an integrated LO amplifier which can be used as an upconverter or downconverter. The chip utilizes a GaAs MESFET technology that results in a small overall chip area of 0.9mm². The 2LO to RF isolation is excellent eliminating the need for additional filtering. The LO amplifier is a single bias (+5V) two stage design with only 0dBm drive requirement. A less stringent oscillator design is made possible by the low LO drive and sub-harmonic nature of the chip. All data is with the chip in a 50 ohm test fixture connected via 0.025mm (1 mil) diameter wire bonds of minimal length <0.31 mm (<12 mils).

Electrical Specifications, $T_A = +25^\circ C$, LO Drive = 0 dBm

Parameter	IF = 1 GHz Vdd = +5.0V			IF = 1 GHz Vdd = +5.0V			Units
	Min.	Typ.	Max.	Min.	Typ.	Max.	
Frequency Range, RF	14 - 21			17 - 20			GHz
Frequency Range, LO	7 - 10.5			8.5 - 10			GHz
Frequency Range, IF	DC - 3			DC - 3			GHz
Conversion Loss		10	13.5		9.5	12	dB
Noise Figure (SSB)		10	13.5		9.5	12	dB
2LO to RF Isolation	30	40		34	40		dB
2LO to IF Isolation	30	40 ~ 50		38	40 ~ 50		dB
IP3 (Input)	0	7		0	7		dBm
1 dB Compression (Input)	-5	0		-4	1		dBm
Supply Current (Idd)		50			50		mA

GaAs MMIC SUB-HARMONICALLY PUMPED MIXER, 14 - 21 GHz

Conversion Gain vs. Temperature @ LO = 0 dBm

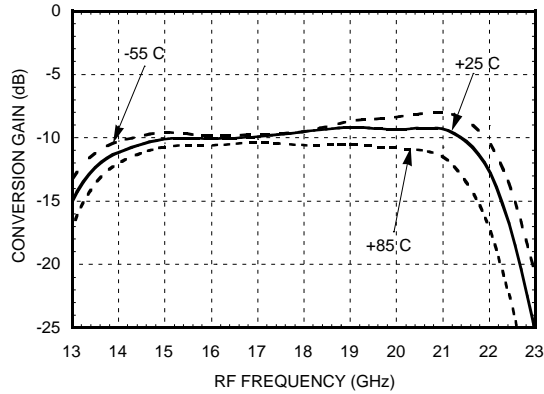

Isolation @ LO = 0 dBm

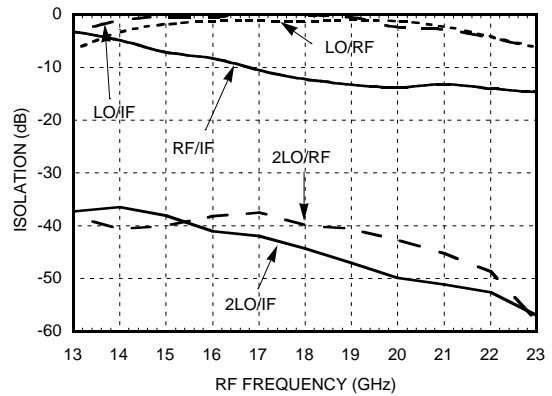

Conversion Gain vs. LO Drive

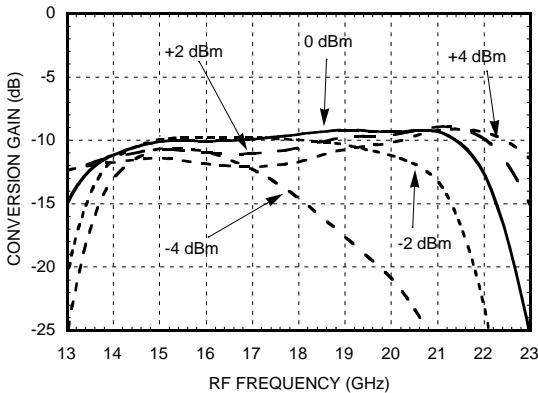

Return Loss @ LO = 0 dBm

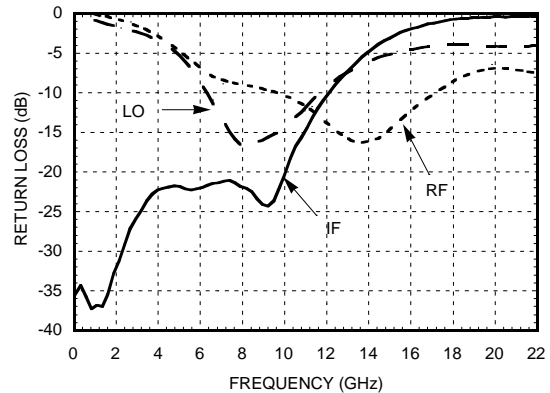

IF Bandwidth @ LO = 0 dBm

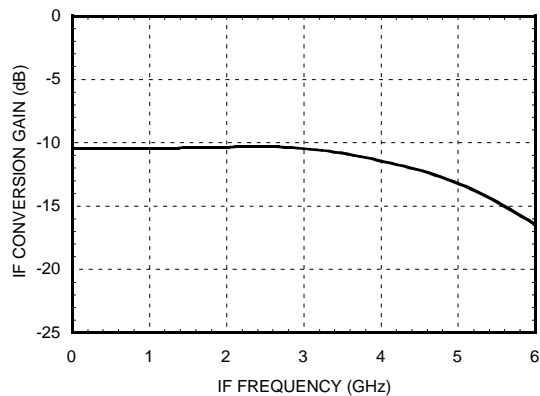

Upconverter Performance Conversion Gain vs. LO Drive

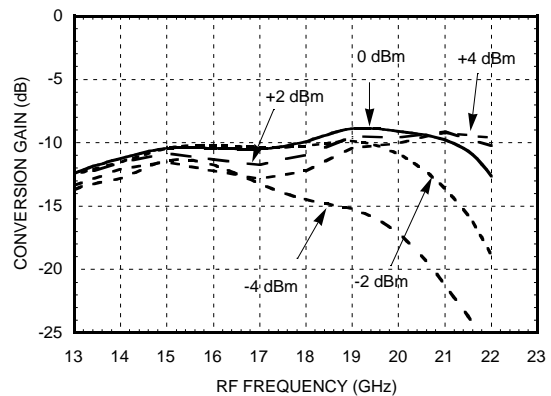

GaAs MMIC SUB-HARMONICALLY PUMPED MIXER, 14 - 21 GHz

Input IP3 vs. LO Drive

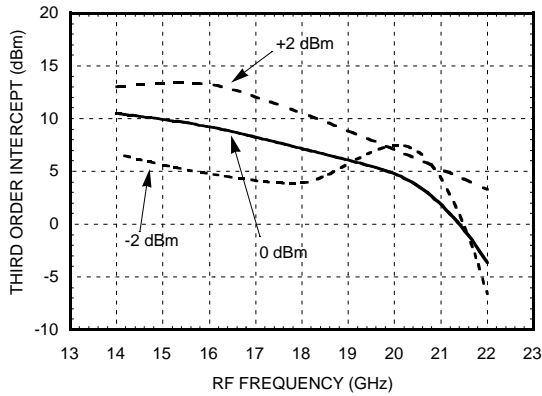

Input IP3 vs. Temperature @ LO = 0 dBm

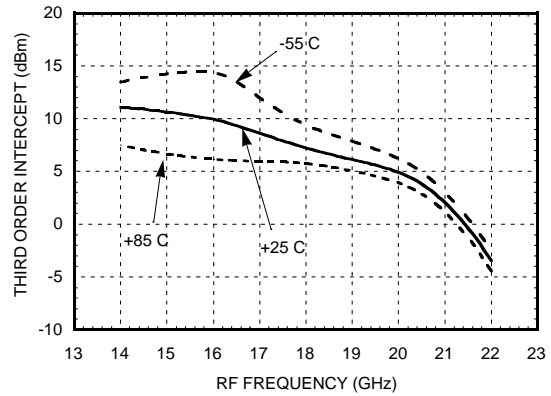

Input IP2 vs. LO Drive

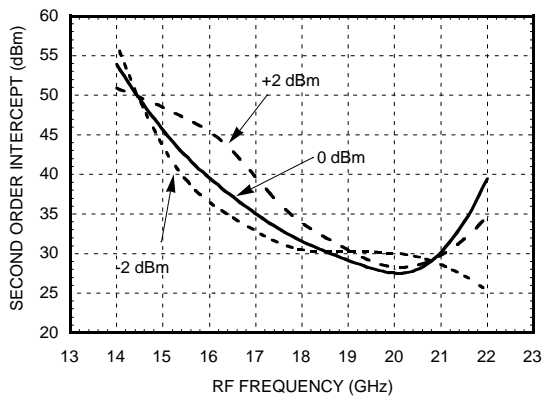

Input IP2 vs. Temperature @ LO = 0 dBm

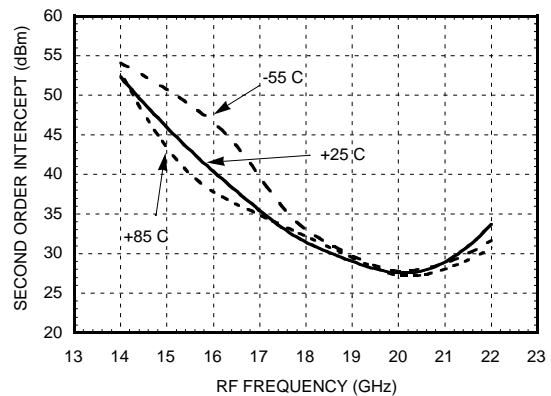

MxN Spurious Outputs @ LO Drive = 0 dBm

mRF	nLO					
	±5	±4	±3	±2	±1	0
-3						
-2	-44					
-1	-57	-18	-52			
0			-9	-26	+20	
1				X	-46	-2
2		-52	-30		-49	
3		-56				

RF = 18 GHz @ -10 dBm
 LO = 8.5 GHz @ 0 dBm
 All values in dBc below the IF power level

P1dB vs. Temperature @ LO = 0 dBm

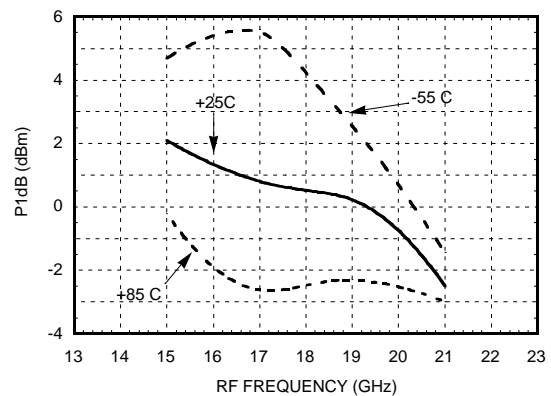

GaAs MMIC SUB-HARMONICALLY PUMPED MIXER, 14 - 21 GHz

Absolute Maximum Ratings

RF / IF Input (Vdd = +5V)	+13 dBm
LO Drive (Vdd = +5V)	+13 dBm
Vdd	+10 Vdc
Storage Temperature	-65 to +150 °C
Operating Temperature	-55 to +85 °C

NOTE: A 100pF single layer chip bypass capacitor is recommended on the Vdd port no further than 0.762mm (30 mils) from the HMC258

Outline Drawing

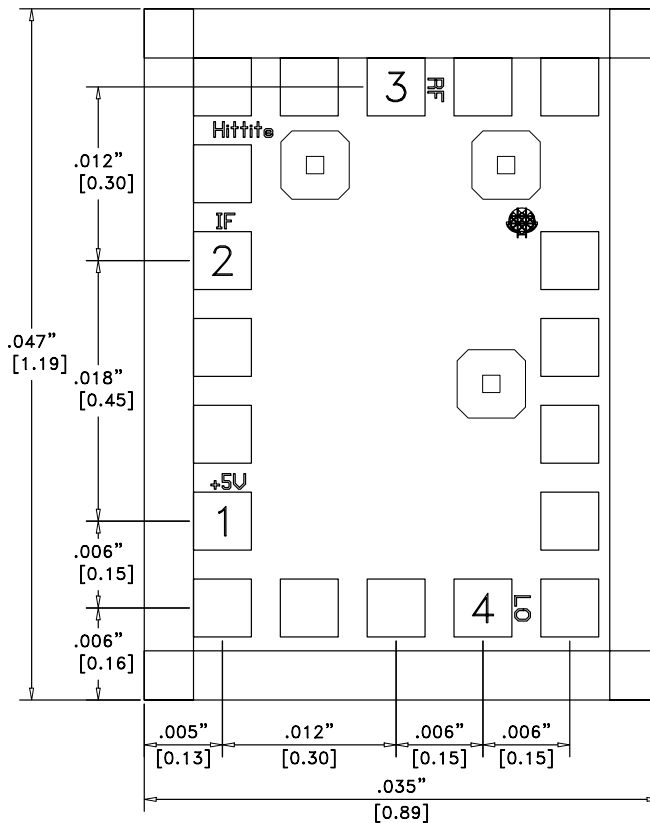

NOTES:

1. ALL DIMENSIONS ARE IN INCHES [MM].
2. BOND PADS ARE .004" SQUARE.
3. TYPICAL BOND PAD SPACING CENTER TO CENTER IS .006".
4. BACKSIDE METALLIZATION: GOLD.
5. BOND PAD METALLIZATION: GOLD.
6. BACKSIDE METAL IS GROUND.
7. CONNECTION NOT REQUIRED FOR UNLABELED BOND PADS.

GaAs MMIC SUB-HARMONICALLY PUMPED MIXER, 14 - 21 GHz

MIC Assembly Techniques

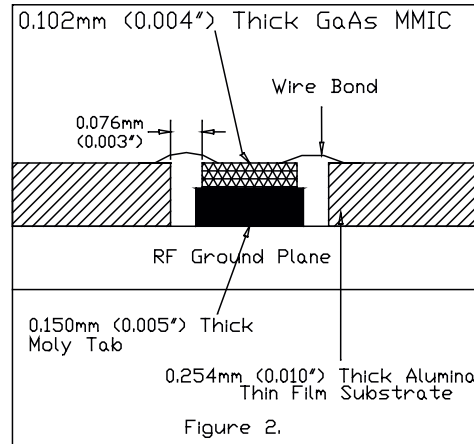
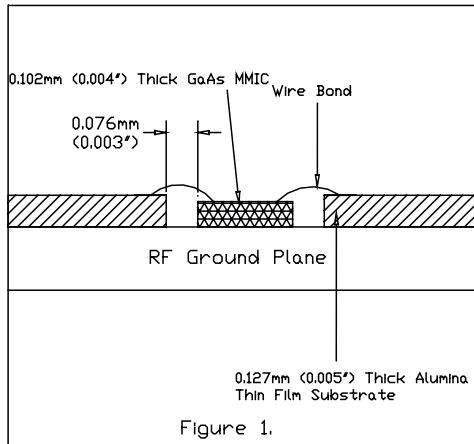

Mounting & Bonding Techniques for Millimeterwave GaAs MMICs

The die should be attached directly to the ground plane eutectically or with conductive epoxy (see HMC general Handling, Mounting, Bonding Note).

50 Ohm Microstrip transmission lines on 0.127mm (5 mil) thick alumina thin film substrates are recommended for bringing RF to and from the chip (Figure 1). If 0.254mm (10 mil) thick alumina thin film substrates must be used, the die should be raised 0.150mm (6 mils) so that the surface of the die is coplanar with the surface of the substrate. One way to accomplish this is to attach the 0.102mm (4 mil) thick die to a 0.150mm (6 mil) thick molybdenum heat spreader (moly-tab) which is then attached to the ground plane (Figure 2).

Microstrip substrates should be brought as close to the die as possible in order to minimize bond wire length. Typical die-to-substrate spacing is 0.076mm (3 mils).

An RF bypass capacitor should be used on the Vdd input. A 100 pF single layer capacitor (mounted eutectically or by conductive epoxy) placed no further than 0.762mm (30 Mil) from the chip is recommended. The photo in figure 3 shows a typical assembly for the HMC258 MMIC chip.

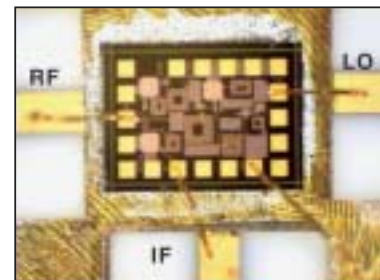

Figure 3: Typical HMC258 Assembly

**GaAs MMIC SUB-HARMONICALLY
PUMPED MIXER, 14 - 21 GHz****Handling Precautions**

Follow these precautions to avoid permanent damage.

Cleanliness: Handle the chips in a clean environment. DO NOT attempt to clean the chip using liquid cleaning systems.

Static Sensitivity: Follow ESD precautions to protect against $> \pm 250V$ ESD strikes.

Transients: Suppress instrument and bias supply transients while bias is applied. Use shielded signal and bias cables to minimize inductive pick-up.

General Handling: Handle the chip along the edges with a vacuum collet or with a sharp pair of bent tweezers. The surface of the chip has fragile air bridges and should not be touched with vacuum collet, tweezers, or fingers.

Mounting

The chip is back-metallized and can be die mounted with AuSn eutectic preforms or with electrically conductive epoxy. The mounting surface should be clean and flat.

Eutectic Die Attach: A 80/20 gold tin preform is recommended with a work surface temperature of 255 °C and a tool temperature of 265 °C. When hot 90/10 nitrogen/hydrogen gas is applied, tool tip temperature should be 290 °C. DO NOT expose the chip to a temperature greater than 320 °C for more than 20 seconds. No more than 3 seconds of scrubbing should be required for attachment.

Epoxy Die Attach: Apply a minimum amount of epoxy to the mounting surface so that a thin epoxy fillet is observed around the perimeter of the chip once it is placed into position. Cure epoxy per the manufacturer's schedule.

Wire Bonding

Ball or wedge bond with 0.025 mm (1 mil) diameter pure gold wire. Thermosonic wirebonding with a nominal stage temperature of 150 °C and a ball bonding force of 40 to 50 grams or wedge bonding force of 18 to 22 grams is recommended. Use the minimum level of ultrasonic energy to achieve reliable wirebonds. Wirebonds should be started on the chip and terminated on the package or substrate. All bonds should be as short as possible < 0.31 mm (12 mils).