

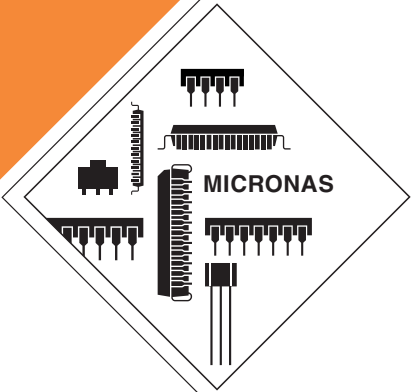

PRELIMINARY DATA SHEET

DAC 3560C

Audio-Subsystem for Portable Applications



Contents

Page	Section	Title
4	1.	Introduction
4	1.1.	Features
4	1.2.	Target Systems
6	2.	Functional Description
6	2.1.	Digital Audio Interface (I ² S)
7	2.2.	Clock System
7	2.3.	Control Interface
7	2.4.	Registers
8	2.5.	I ² C Bus Interface
8	2.6.	SPI Bus Interface
8	2.7.	Noise Shaper and Multibit DAC
8	2.8.	Analog Low-Pass Filter
8	2.9.	Analog Input
9	2.10.	Analog Audio Driver Output
9	2.11.	LDO
9	2.12.	Charge Pump
9	2.13.	Reference Block
9	2.14.	Temperature Overload Protection
9	2.15.	Power Management
9	2.16.	Click and Pop Suppression
10	3.	Control Registers
10	3.1.	Register Map
14	4.	Specifications
14	4.1.	Outline Dimensions
16	4.2.	Pin Connections and Short Descriptions
18	4.3.	Pin Descriptions
18	4.3.1.	Power Supply Pins
18	4.3.2.	Exposed Die Pad
18	4.3.3.	Analog Reference Pins
19	4.3.4.	Analog Audio Pins
19	4.3.5.	Digital Audio Input Pins
19	4.3.6.	Control Interface Pins
19	4.3.7.	Other Pins
20	4.4.	Pin Configurations
20	4.5.	Pin Circuits
22	4.6.	Electrical Characteristics
22	4.6.1.	Absolute Maximum Ratings
24	4.6.2.	Recommended Operating Conditions
24	4.6.2.1.	General Recommended Operating Conditions
25	4.6.3.	Characteristics (LDO Mode)
28	4.6.4.	Characteristics (Non-LDO Mode)
30	4.6.5.	Terminology
31	4.6.6.	Digital Characteristics
31	4.6.6.1.	I ² C Bus Characteristics
32	4.6.6.2.	I ² S Bus Characteristics

Contents, continued

Page	Section	Title
33	4.6.6.3.	Reset Input Characteristics
33	4.6.6.4.	Mode Input Characteristics
34	4.6.6.5.	SPI-Bus Characteristics
35	4.6.7.	Power Consumption (LDO Mode)
36	5.	Detailed Mode Description
36	5.1.	LDO Mode, Using the internal Low-Dropout Regulator
36	5.2.	Non-LDO Mode, Using the DAC 3560C without the LDO
37	5.3.	Headphone Common Driver
38	5.3.1.	Digital Supply
38	5.3.2.	Power On/Off Sequence
39	6.	Application Circuit
40	6.1.	Suggestions for System Debugging
42	7.	Data Sheet History

Audio-Subsystem for Portable Applications

Release Note: Revision bars indicate significant changes to the previous edition. This document is valid for version B1 and following versions.

1. Introduction

The DAC 3560C is a single-chip, high-precision, dual digital-to-analog converter designed for audio applications. The employed conversion technique is based on oversampling with noise-shaping.

With Micronas' unique multibit sigma-delta technique, less sensitivity to clock jitter, high linearity, and a superior S/N ratio have been achieved. The DAC 3560C is controlled via SPI or I²C bus.

Digital audio input data is received via a versatile I²S interface. The DAC 3560C provides three integrated power audio drivers: a stereo headphone, a mono earpiece and a mono loudspeaker driver. Moreover, mixing additional analog sources to the D/A-converted signal is supported.

For applications with a noise-critical power supply environment, the DAC 3560C is equipped with an integrated low drop-out voltage regulator (LDO). The LDO provides a stable 2.85 V output voltage and is intended for supplying the headphone and earpiece drivers. With the LDO, the power supply rejection ratio (PSRR) of the audio outputs is improved to more than 100 dB.

The DAC 3560C is designed for all kinds of applications in the audio and multimedia field, such as mobile phones, PDAs, and digital audio players.

1.1. Features

- Three integrated short-circuit-protected power audio drivers are provided:
 1. Stereo headphone output (25 mW at $V_{SUP}=2.85$ V, or 80 mW at $V_{SUP}=5$ V respectively)
 2. Mono earpiece output (100 mW at $V_{SUP}=2.85$ V, or 300 mW at $V_{SUP}=5$ V, respectively)
 3. Mono loudspeaker output (400 mW at $V_{SUP}=3$ V, or 1.1 W at $V_{SUP}=5$ V, respectively)
- integrated LDO (Low Drop-Out Regulator)
- 100 dB PSRR
- 98 dB (A) dynamic range multibit Sigma Delta DAC
- continuous sample rates from 8 kHz to 192 kHz
- capacitor-free headset connection
- analog stereo and mono line inputs with programmable gain
- I²C/SPI-compatible serial control ports
- I²S digital audio interface
- programmable power management
- –30 dB to 6 dB analog volume, mute
- 2.2 V to 5.5 V supply voltage
- 1.8 V to 5.5 V digital I/O voltage
- standby mode
- zero-power mode (< 10 μ A)
- PQFN40-1 and PMQFP44-1 packages

1.2. Target Systems

- PDAs
- hand-held terminals
- mobile and cordless phones
- portable MP3 and CD players

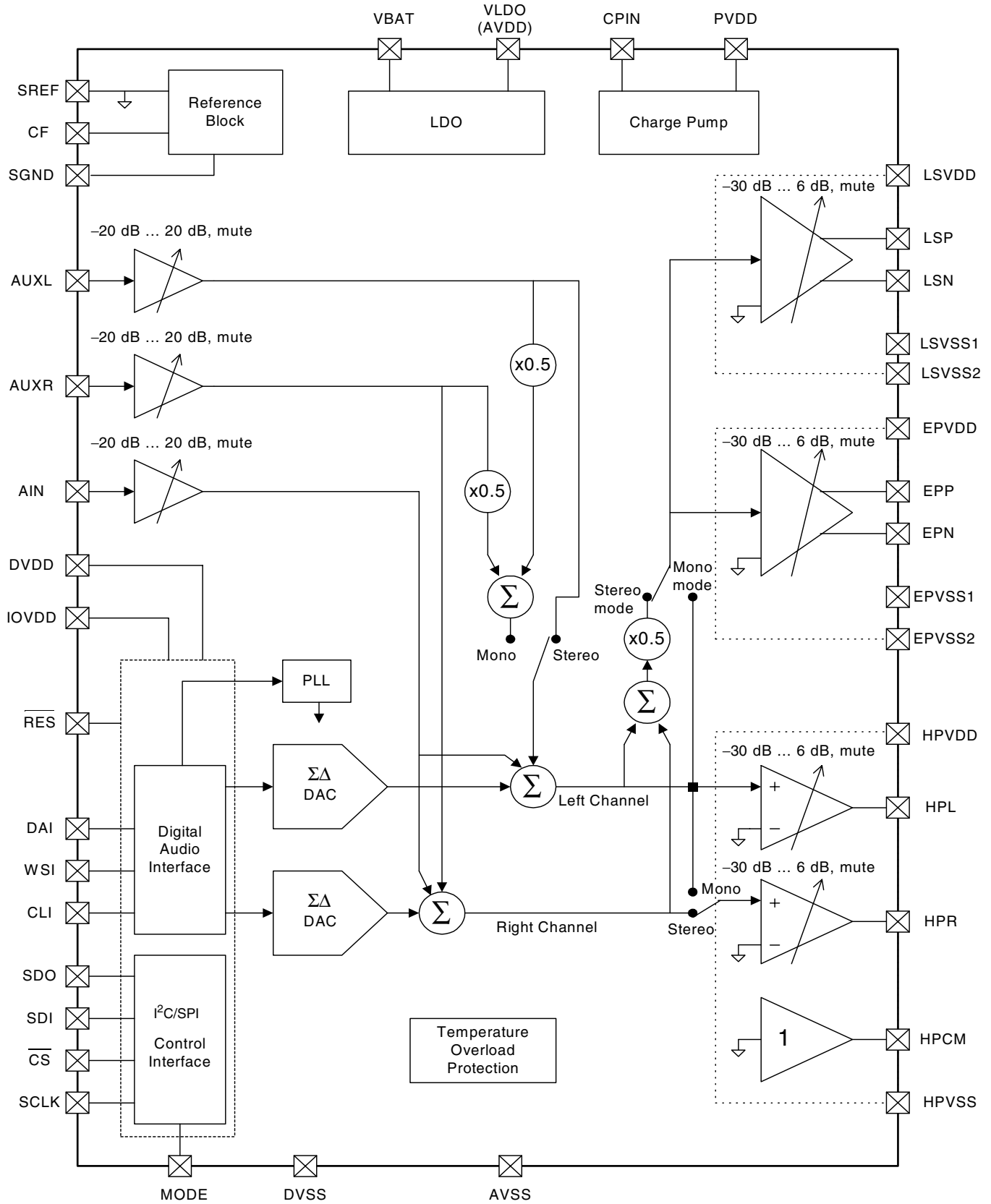

Fig. 1-1: Block diagram

2. Functional Description

The main blocks are described in the following chapters. All functions are controlled via I²C/SPI protocol.

2.1. Digital Audio Interface (I²S)

The I²S interface is the digital audio interface between the DAC 3560C and external digital audio sources. It covers most of the I²S-compatible formats. All modes have two common features:

1. The MSB is left-justified to an I²S frame identification (WSI) transition.
2. Data is valid on the rising edge of the bit clock CLI.

16-bit mode:

In this case, the bit clock is $32 \times f_{s_audio}$. Maximum word length is 16 bit.

32-bit mode:

In this case, the bit clock is $64 \times f_{s_audio}$. Maximum word length is 32 bit.

Automatic Detection:

No I²C/SPI control is required to switch between 16-bit and 32-bit mode. It is recommended to switch the DAC 3560C into mute position while alternating between the two modes. For high-quality audio, it is recommended to use the 32-bit mode of the I²S interface to make use of the full dynamic range (if more than 16 bits are available).

Left-Right Selection:

Standard I²S format defines an audio frame always starting with the left channel and low-state of WSI. However, the DAC 3560C permits changing the polarity of WSI.

Delay Bit:

The standard I²S format requires a delay of one clock cycle between transitions of WSI and data MSB. In order to fit other formats, however, this characteristic can be switched on or off.

Note: Volume mute should be applied before changing I²S mode in order to avoid audible clicks

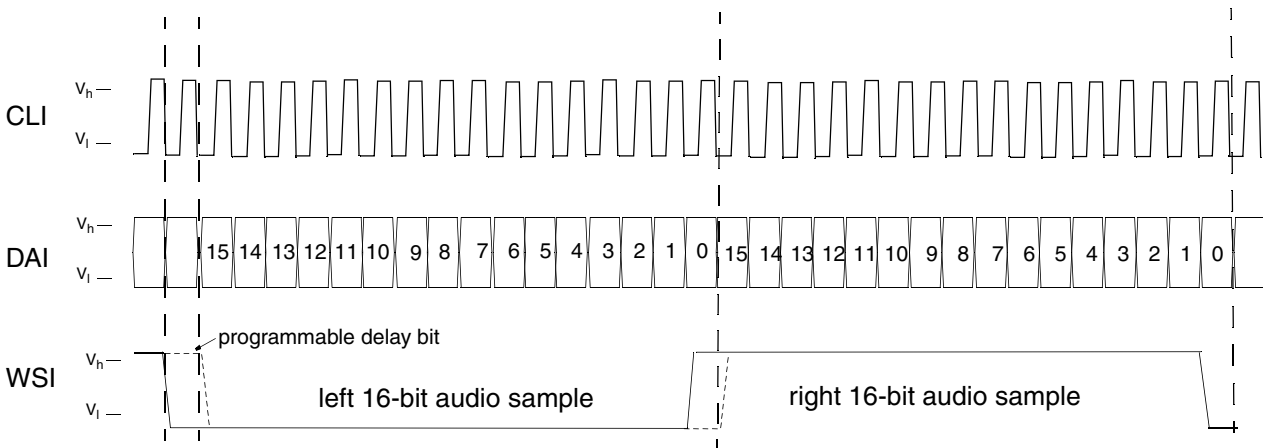

Fig. 2-1: I²S 16-bit mode

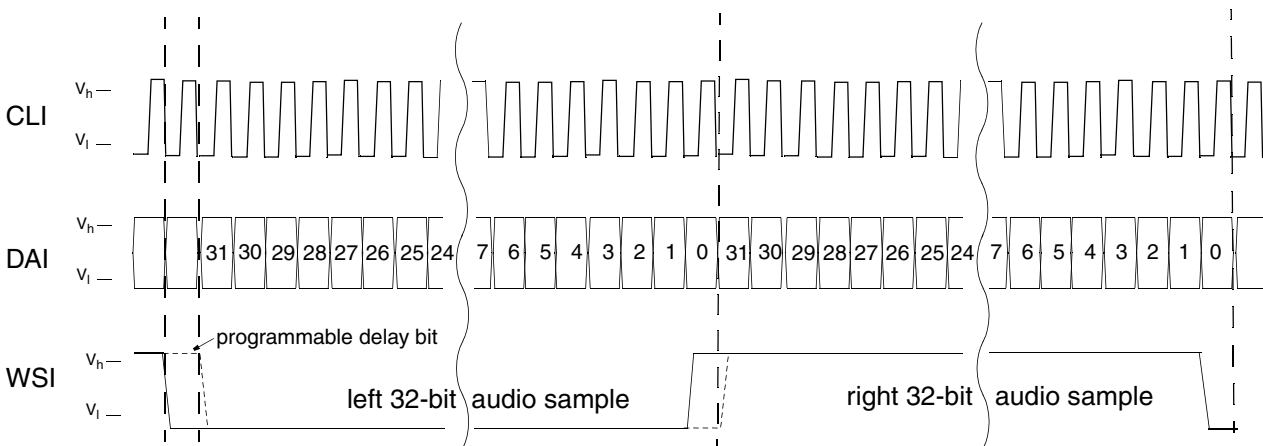

Fig. 2-2: I²S 32-bit mode

2.2. Clock System

Most DACs need $256 \times f_{s_audio}$, $384 \times f_{s_audio}$, or at least an asynchronous clock. The DAC 3560C does not need an external Master clock. No crystal is required.

All internal clocks are generated by an internal PLL circuit, which locks to the I²S bit clock (CLI). If no I²S clock is available, the IC can still be controlled via I²C, SPI and the analog signal path is still available as no I²S clock is needed for this.

The PLL generates the clock for the DAC and the noise shaping system. Audible oversampling artifacts even at low audio sampling frequencies are eliminated.

2.3. Control Interface

The DAC 3560C has many register-programmable features. The control interface is used to program the registers of the device. It uses four pins:

SCLK - Serial Data Clock

SDI - Serial Data Input (Input/Output for I²C)

SDO - Serial Data Output (SPI)

\overline{CS} - Chip Select (SPI)

Table 2–1: Standard Protocols

MODE Pin	Control Protocol
1	I ² C
0	SPI

The control interface supports two standard protocols, the I²C protocol (two-wire operation) and the SPI protocol (three or four-wire operation). The state of the MODE pin selects the control interface type.

2.4. Registers

All registers of the DAC 3560C are 8 bits wide and offer read/write access.

In Section 3. “Control Registers”, a definition of the DAC 3560C control registers is shown. A hardware reset initializes all control registers to 0, which is the default value for all registers. The registers are addressed by the sub-address byte, which follows the device address in I²C mode and is the first byte to be sent in SPI mode. The structure of the sub-address is identical in both modes (R/W is ignored in I²C mode).

Table 2–2: Sub-Address Byte

Bit	D7	D6	D5	D4	D3	D2	D1	D0
Function	0	0	R/W	A4	A3	A2	A1	A0

Table 2–3: Structure of the Sub-Address Byte

R	Reserved	Set to 0	
R/W ¹⁾	Read/Write Access	1=Read	0=Write
A [4:0]	Control Interface Sub-Address		
¹⁾ R/W must be set to 0 in I ² C mode			

2.5. I²C Bus Interface

The DAC 3560C is equipped with an I²C bus slave interface. The I²C bus interface uses one level of sub-addressing: the I²C device address is used to address the IC. The registers are readable and writable. The register address is incremented automatically at each data byte unless a stop condition occurs. The I²C device address is given below.

Table 2-4: I²C device address byte

A7	A6	A5	A4	A3	A2	A1	W/R
1	0	0	1	1	0	1	0/1

Fig. 2-3 shows I²C bus protocols for write and read operations of the interface; the read operations require an extra start condition and repetition of the chip address with the device read command (DR). Fields with signals/data originating from the DAC 3560C are marked with a gray background.

Example: I²C single write access



Example: I²C single read access

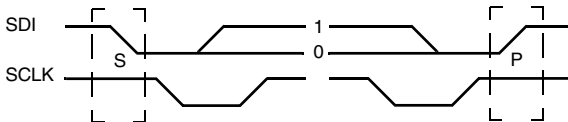

Fig. 2-3: Example of an I²C protocol for the DAC 3560C (MSB first; data must be stable while clock is high)

Abbreviations:

- A = Acknowledge
- N = Not Acknowledge (NAK)
- S = Start
- P = Stop
- DW = I²C Device Write Address (9A_{hex})
- DR = I²C Device Read Address (9B_{hex})

2.6. SPI Bus Interface

The SPI bus is a 4-wire serial communications interface. Unlike the I²C bus, the SPI uses two separate pins for input and output and \overline{CS} signal instead of individual device addresses.

Read and write starts with a low signal at \overline{CS} . The first byte is always interpreted as sub-address byte, which

contains the Register address. The following byte or bytes are then read/write register data.

If more than one data byte appears without changing \overline{CS} , the register address will be incremented automatically at each data byte.

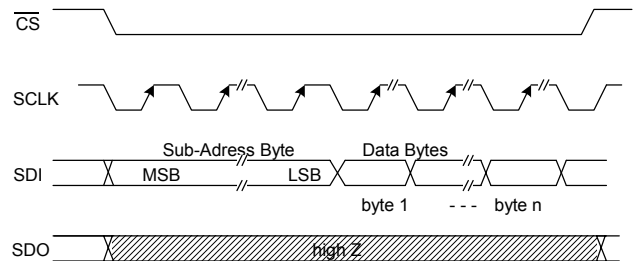

Fig. 2-4: SPI Control Port - Write Access

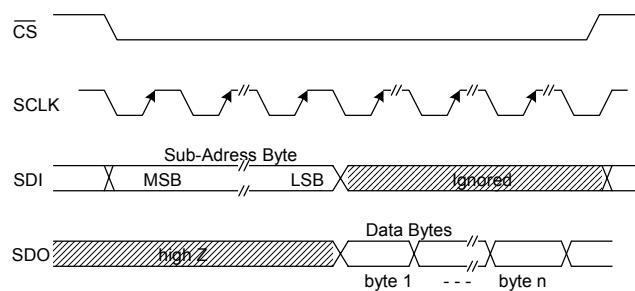

Fig. 2-5: SPI Control Port - Read Access

2.7. Noise Shaper and Multibit DAC

The input signal is interpolated to a higher sampling rate. A successive noise shaper converts the oversampled audio signal into a multibit noise-shaped signal. This technique results in extremely low quantization noise in the audio band.

2.8. Analog Low-Pass Filter

The multibit DAC is followed by a third-order analog low-pass filter with a cut-off frequency of approximately 70 kHz. It removes the out-of-band components of the oversampled audio signal.

2.9. Analog Input

In addition to the digital audio input, the DAC 3560C provides three analog inputs, (AUXL, AUXR, AIN) for stereo and mono signals. The analog audio signals can be mixed to the digital audio signal as well as being used without digital audio. All three analog inputs are equipped with 20 dB to -20 dB gain controls for individual input level adjustments in steps of 2 dB. They feature additional mute position.

2.10. Analog Audio Driver Output

The device provides three integrated audio drivers.

Table 2–5: Analog Audio Driver Output

Integrated Audio Drivers	
Stereo headphone driver	25 mW at 2.85 V supply 80 mW at 5 V supply
Mono earpiece driver	100 mW at 2.85 V supply 300 mW at 5 V supply
Mono loudspeaker driver	400 mW at 3 V supply 1.1 W at 5 V supply

All drivers are equipped with analog volume controls, which are individually adjustable from 6 dB to –30 dB in 1.5 dB steps and mute. The earpiece driver and the loudspeaker driver have differential outputs, while the headphone drivers are single-ended. Single-ended drivers usually require a large coupling capacitor to block the DC bias from the headphone. The DAC 3560C provides a headphone common output (HPCM), which eliminates the need for such bulky DC-blocking capacitors. The headphone and earpiece drivers are short-circuit protected. The loudspeaker output pins are not short-circuit-proof.

2.11. LDO

For applications with a noise-critical power supply environment, the DAC 3560C is equipped with an integrated Low-Dropout Voltage Regulator (LDO). The LDO provides a stable 2.85 V output voltage and is intended to supply the headphone and earpiece drivers. With the LDO, the Power Supply Rejection Ratio (PSRR) of the audio outputs is improved to more than 100 dB.

For applications where the LDO cannot be used, e.g., for supply voltages below 2.85 V, it can be disabled via the Mode-Control-Register, (see Section 5.) for details on using the DAC 3560C with or without the internal LDO. The LDO is short-circuit-protected.

2.12. Charge Pump

The DAC 3560C offers an internal charge pump circuit that allows to operate the IC with a supply voltage as low as 2.2 V. An additional capacitor must be connected between pin PVDD and pin VLDO for the charge pump to work properly. The switching frequency is far above the audio range and therefore does not interfere with the audio signals. The charge pump must be turned on if the supply voltage of the IC drops below 2.7 V. (see Section 5.) for details on using the DAC 3560C with a lowered supply voltage of 2.2 V.

2.13. Reference Block

This block provides the reference level for the analog audio signals. Two modes are possible:

LDO-Mode: The audio reference level is fixed to 1.425 V (Pin SREF), which is one half of the LDO output voltage.

Non-LDO Mode: The audio reference level at Pin SREF is derived from an internal voltage divider to VBAT/2.

A capacitor connected between SREF and SGND reduces the noise coming from SREF. In addition, a second capacitor can be connected to pin CF to form a second order noise filter. (See Section 5. for details).

2.14. Temperature Overload Protection

The DAC 3560C has an internal temperature overload protection, which disables all audio drivers and the LDO, if the junction temperature exceeds 145 °C. Once the chip has cooled down to 130 °C, the LDO and the audio drivers are enabled again.

2.15. Power Management

As the device has more than one signal path, the DAC 3560C offers a block-control register, which permits individual control over the power state of the signal chain for optimized power consumption. A Zero Power and a Standby Mode are also provided.

2.16. Click and Pop Suppression

The DAC 3560C has on-chip facilities allowing to turn the audio output drivers on or off without audible click and pop transients.

3. Control Registers

The DAC 3560C contains 11 registers (all 8 bits). All registers, with the exception of the Reset Register, (write only), allow read and write access.

Note: The default value for all registers after software or hardware reset is 0.

3.1. Register Map

Table 3–1: Register Map Table

Sub-Address	Register
00h	Reset Register
01h	Block Control Register
02h	Mode Control Register
03h	I ² S Interface Control Register
04h	Left Headphone Volume Control
05h	Right Headphone Volume Control
06h	Earpiece Volume Control
07h	Loudspeaker Volume Control
08h	Left Input Aux Gain Control
09h	Right Input Aux Gain Control
0Ah	Ain Input Gain Control
0Bh...FFh	Reserved

Table 3–2: Register Description

Name	Sub-Address	Dir	Default after Reset	Function
DACC-Register				
Reset Register	h00	W	h00	
Reset	h0X	W	0	Writing to this register clears all internal registers to their default reset value
Block Control Register	h01	RW	h00	Ignored, if in Standby or Zero Power Mode
PDAC	h01[7]	RW	0	1 = On, 0 = Off (Power DAC)
PAIN	h01[6]	RW	0	1 = On, 0 = Off (Power Ain) Gain
PAUX	h01[5]	RW	0	1 = On, 0 = Off (Power Aux) Gain
PL	h01[4]	RW	0	1 = On, 0 = Off (Power Loudspeaker) Driver
PE	h01[3]	RW	0	1 = On, 0 = Off (Power Earpiece) Driver
PRH	h01[2]	RW	0	1 = On, 0 = Off (Power Right Headphone) Driver
PLH	h01[1]	RW	0	1 = On, 0 = Off (Power Left Headphone) Driver
ENHPC	h01[0]	RW	0	1 = On, 0 = Off (Enable Headphone Common Output) Driver

Table 3–2: Register Description, continued

Name	Sub-Address	Dir	Default after Reset	Function
Mode Control Register	h02	RW	h00	For details, please refer to Section 5.
–	h02[7]	RW	0	Reserved
RDWN	h02[6]	RW	0	1 = On, 0 = Off (Ramp down SREF during Stand-by Mode)
CPON	h02[5]	RW	0	1 = On, 0 = Off (Charge pump on, only in NON-LDO Mode)
BYPLDO	h02[4]	RW	0	1 = On, 0 = Off (Bypass LDO (only in Standby, Zero Power)
SNLDOM	h02[3]	RW	0	1 = On, 0 = Off (Select Non-LDO Mode)
SMM	h02[2]	RW	0	1 = Mono, 0 = Stereo (Select Stereo or Mono Mode)
PM	h02[1:0]	RW	0	PM[1:0] 00 Zero Power Mode 01 Standby Mode 11 Operating Mode 10 Reserved
I2S Interface Control Register	h03	RW	h00	
–	h03[7:5]	RW	0	Reserved
POL	h03[4]	RW	0	Invert Polarity of Word Strobe Input POL=0 - Left Channel → WSI=0 POL=1 - Right Channel → WSI=0
DEL	h03[3]	RW	0	1 = Delay, 0 = no Delay (Delay Bit)
SR	h03[2:0]	RW	0	SR[2:0] 000 32 kHz - 48 kHz Sample Rate 001 24 kHz - 32 kHz Sample Rate 010 16 kHz - 24 kHz Sample Rate 011 12 kHz - 16 kHz Sample Rate 100 8 kHz - 12 kHz Sample Rate 101 6 kHz - 8 kHz Sample Rate 110 96 kHz Sample Rate 111 192 kHz Sample Rate
Left Headphone Volume Register	h04	RW	h00	
–	h04[7:5]	RW	0	Reserved
LHV	h04[4:0]	RW	0	LHV[4:0] Left Headphone Volume 00000 Mute 00001 –30 dB ----- in steps of 1.5 dB 11001 6 dB 11010-11111 6 dB

Table 3–2: Register Description, continued

Name	Sub-Address	Dir	Default after Reset	Function
Right Headphone Volume Register	h05	RW	h00	
–	h05[7:5]	RW	0	Reserved
RHV	h05[4:0]	RW	0	RHV[4:0] Right Headphone Volume 00000 Mute 00001 –30 dB ----- in steps of 1.5 dB 11001 6 dB 11010-11111 6 dB
Earpiece Volume Register	h06	RW	h00	
–	h06[7:5]	RW	0	Reserved
EV	h06[4:0]	RW	0	EV[4:0] Earpiece Volume 00000 Mute 00001 –30 dB ----- in steps of 1.5 dB 11001 6 dB 11010-11111 6 dB
Loudspeaker Volume Register	h07	RW	h00	
–	h07[7:5]	RW	0	Reserved
LV	h07[4:0]	RW	0	LV[4:0] Loudspeaker Volume 00000 Mute 00001 –30 dB ----- in steps of 1.5 dB 11001 6 dB 11010-11111 6 dB
Left Aux Gain Register	h08	RW	h00	
–	h08[7:5]	RW	0	Reserved
ALV	h08[4:0]	RW	0	ALV[4:0] Left AUX Pre-Amplifier Gain 00000 Mute 00001 –20 dB ----- in steps of 2 dB 10101 20 dB 10110-11111 20 dB

Table 3–2: Register Description, continued

Name	Sub-Address	Dir	Default after Reset	Function
Right AUX Gain Register	h09[7:5]	RW	h00	
–	h09[7:5]	RW	0	Reserved
ARV	h09[4:0]	RW	0	ARV[4:0] Right AUX Pre-Amplifier Gain 00000 Mute 00001 –20 dB ----- in steps of 2 dB 10101 20 dB 10110-11111 20 dB
AIN Gain Register	h0A[7:5]	RW	h00	
–	h0A[7:5]	RW	0	Reserved
AIV	h0A[4:0]	RW	0	AIV[4:0] AIN Pre-Amplifier Gain 00000 Mute 00001 –20 dB ----- in steps of 2 dB 10101 20 dB 10110-11111 20 dB

4. Specifications

4.1. Outline Dimensions

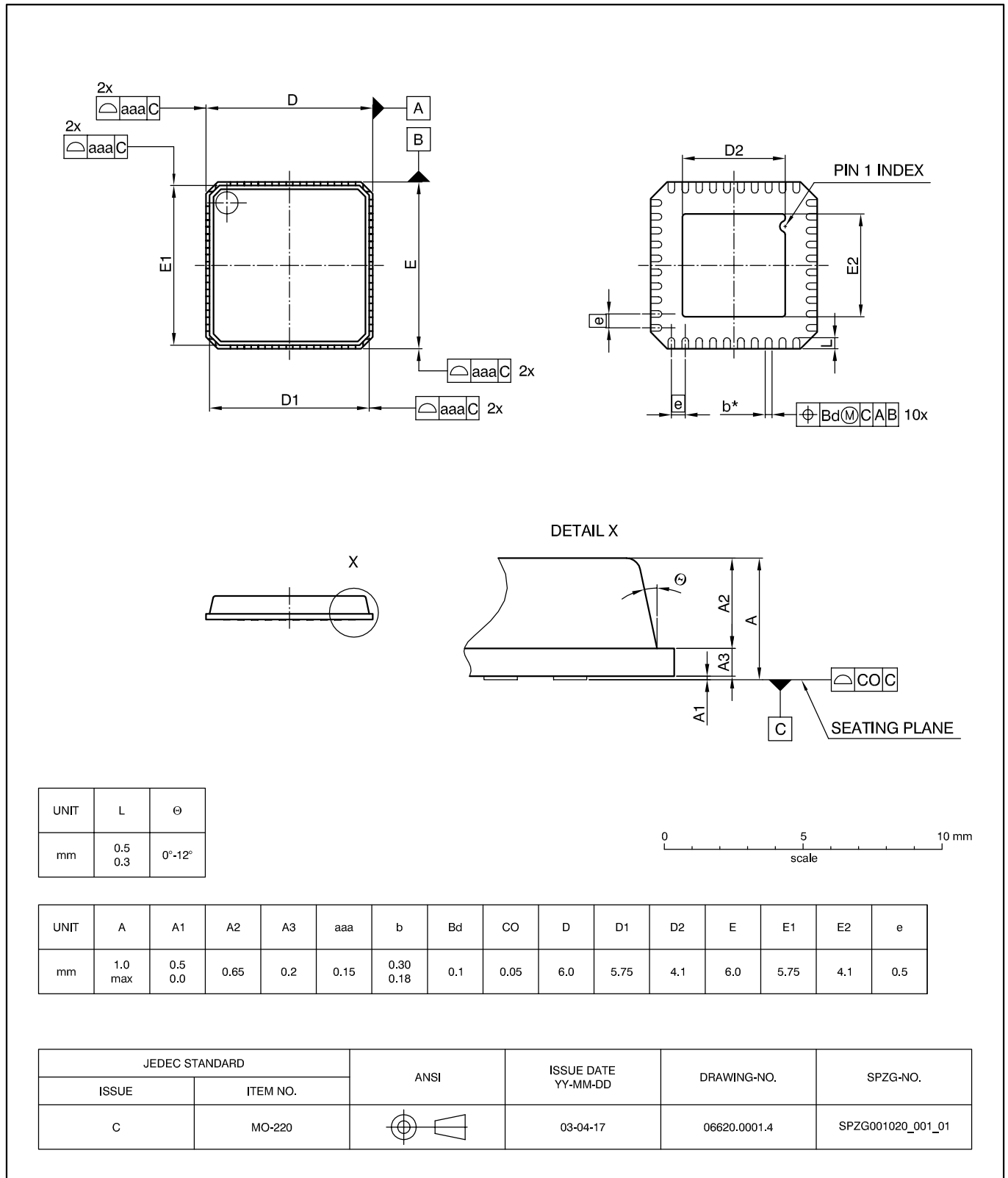

Fig. 4-1:
PQFN40-1: Plastic Quad Flat Non-leaded package, 40 pins, 6 × 6 × 0.85 mm³, 0.5 mm pitch
 Ordering code: XN
 Weight approximately 0.1 g

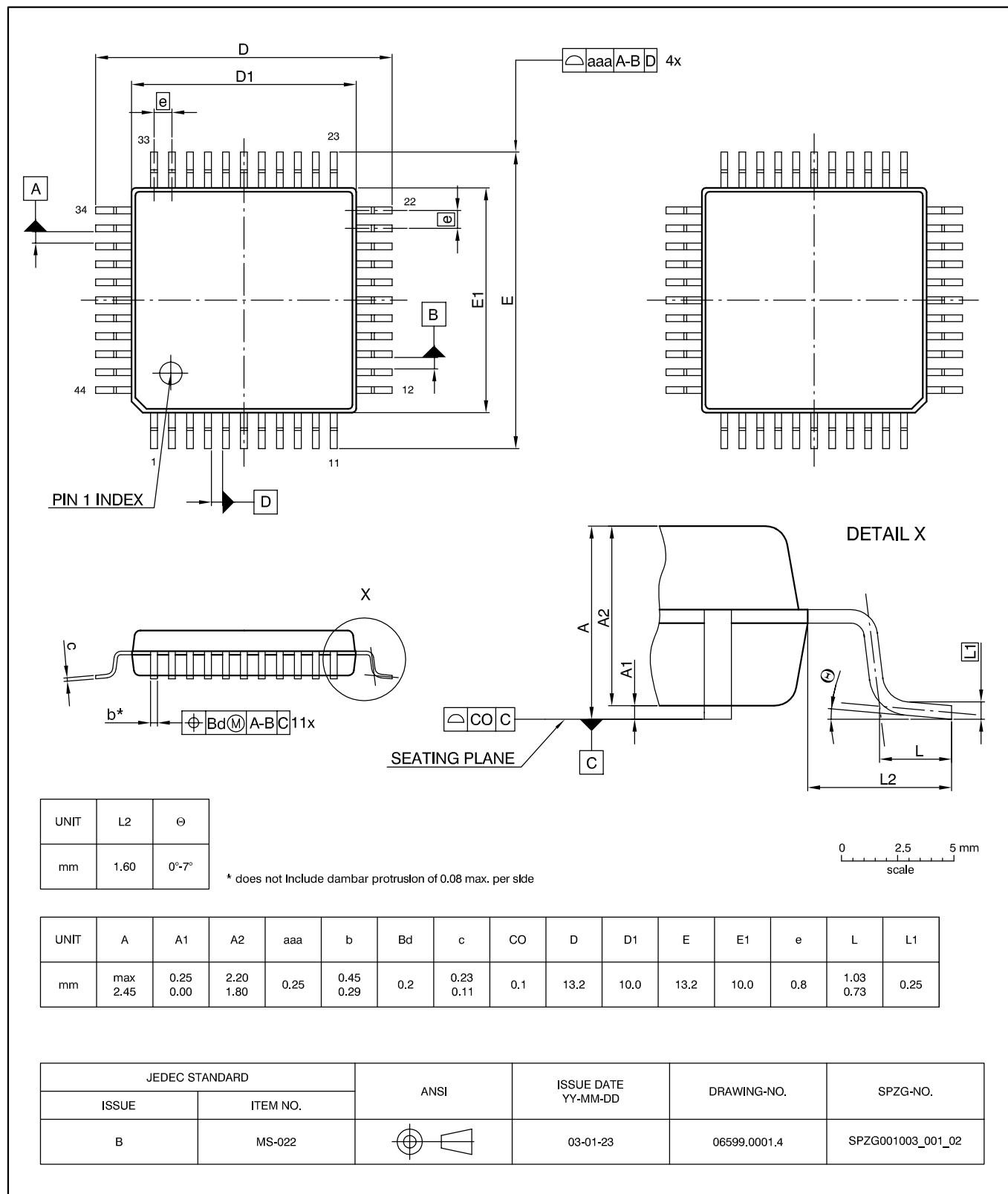

Fig. 4-2:
PMQFP44-1: Plastic Metric Quad Flat Package, 44 leads, 10 × 10 × 2 mm³
 Ordering code: QG
 Weight approximately 0.5 g

4.2. Pin Connections and Short Descriptions

NC = not connected

LV = leave vacant

IN = Input, OUT = Output, IN/OUT = Input/Output

P = Power

GND = Ground

OBL = obligatory;

connect as described in the circuit diagram

Pin No.		Pin Name	Type	Connection (If not used)	Short Description
PQFN 40-1	PMQFP 44-1				
1	1	VBAT	P	–	Power Supply
2	2	LSVSS1	P	GND	Loudspeaker Driver Ground
3	3	LSP	OUT	LV	Loudspeaker Differential Positive Output
4	4	LSVDD	P	VBAT	Loudspeaker Power Supply Driver
5	5	LSN	OUT	LV	Loudspeaker Differential Negative Output
6	6	LSVSS2	P	GND	Loudspeaker Driver Ground
7	7	DVDD	P	–	Digital Power Supply
8	8	DVSS	P	GND	Digital Ground
9	9	MODE	IN	OBL	I ² C / SPI Control Mode Selection
10	10	IOVDD	P	–	Digital I/O Power Supply
11	13	SDI	IN/OUT	OBL	SPI / Data In (I ² C Data In/Out)
12	14	SCLK	IN	OBL	SPI / I ² C CLK
13	15	SDO	OUT	LV	SPI / Data Out
14	16	\overline{CS}	IN	GND	SPI Chip Select (active Low)
15	17	DAI	IN	GND	I ² S Data In
16	18	WSI	IN	GND	I ² S Word Strobe In
17	19	CLI	IN	GND	I ² S Clock In
18	20	\overline{RES}	IN	OBL	Reset Input (active Low)
19		NC		NC	Not connected
20		NC		NC	Not connected
21	24	AIN	IN	LV	Analog Mono Input
22	25	AUXL	IN	LV	Analog AUX Input Left Channel
23	26	AUXR	IN	LV	Analog AUX Input Right Channel
24	27	HPCM	OUT	LV	Headphone Common Output
25	28	HPVSS	P	GND	Headphone Driver Ground
26	29	HPL	OUT	LV	Headphone Output Left Channel

Pin No.		Pin Name	Type	Connection (If not used)	Short Description
PQFN 40-1	PMQFP 44-1				
27	30	HPR	OUT	LV	Headphone Output Right Channel
28	31	HPVDD	P	VLDO	Headphone Driver Power Supply
29	32	SGND	P	GND	Ground for Audio Signal reference level, Connect to GND
30	33	SREF	OUT	OBL	Audio Signal reference level
31	34	CF	OUT	SREF	Audio Signal reference level
32	35	EPVSS2	P	GND	Earpiece Driver Ground
33	36	EPN	OUT	LV	Earpiece Differential Negative Output
34	37	EPVDD	P	VLDO	Earpiece Driver Power Supply
35	38	EPP	OUT	LV	Earpiece Differential Positive Output
36	39	EPVSS1	P	GND	Earpiece Driver Ground
37	40	AVSS	P	GND	Analog Ground
38	41	PVDD	OUT	VLDO	Charge Pump Out
39	42	CPIN	P	OBL	Charge Pump In
40	43	VLDO (AVDD)	P	VBAT	LDO Output, Analog Power Supply
	11, 12, 21, 22, 23, 44	NC		NC	Not connected

Note: Pins CPIN, EPVDD, and HPVDD must be connected to Pin VLDO

4.3. Pin Descriptions

4.3.1. Power Supply Pins

The power supply pins are divided into functional regions: LDO region, digital region, digital input region, three analog regions. Two major applications are possible: LDO mode or Non-LDO mode. They are described in detail in Section 5.1. and Section 5.2.

DVDD, IOVDD, DVSS

(see Fig. 4–11, Fig. 4–12, Fig. 4–13, Fig. 4–16):

- The DVDD pin supplies all internal digital parts of the DAC 3560C and the $\overline{\text{RES}}$ input.
- The IOVDD pin supplies all digital inputs and outputs of the DAC 3560C, except the $\overline{\text{RES}}$ input.
- DVSS is the ground connection for all digital circuits.

AVSS, PVDD, CPIN (see Fig. 4–6):

VBAT, VLDO (see Fig. 4–7):

VBAT is the input of the internal LDO.

VLDO is the output of the LDO. If the LDO function is not used, VBAT must be connected to VLDO. At PVDD an internal supply can be generated. Pin CPIN must be connected to VLDO. This function is necessary in Non-LDO mode and external power voltages below 2.7 V. At these low supply voltages, an internal charge pump ensures proper functioning of the chip down to 2.2 V. An external capacitor of 47 nF must be connected from PVDD to VLDO. AVSS serves as ground pin for the aforementioned capacitor and must be connected to DVSS.

HPVDD, HPVSS (see Fig. 4–9, Fig. 4–10)

The HPVDD and HPVSS pins supply the headphone drivers. HPVDD must be connected to VLDO. HPVSS must be connected to AVSS.

EPVDD, EPVSS (see Fig. 4–14)

The EPVDD and EPVSS pins supply the earpiece drivers. EPVDD must be connected to VLDO. EPVSS must be connected to AVSS.

LSVDD, LSVSS (see Fig. 4–15)

The LSVDD and LSVSS pins supply the loudspeaker drivers. LSVDD must be connected to VBAT. LSVSS must be connected to AVSS.

4.3.2. Exposed Die Pad

The exposed die pad on the bottom side is electrically connected to the substrate of the chip. Leave it unconnected or connect it to a clean ground.

4.3.3. Analog Reference Pins

SREF, CF (see Fig. 4–5):

Reference for analog audio signals. SREF is used as reference for the internal op amps and drivers. There are two modes of usage:

1. LDO mode:

SREF must be blocked against SGND with a 3.3 μF (plus optional 10 nF) capacitor.

CF must be connected to SREF.

The internal reference is fixed at 1.425 V.

2. Non-LDO mode (ratiometric mode):

a) SREF and CF are connected together. Both are blocked against SGND with a 3.3 μF (+ optional 10 nF capacitor). The PSRR of SREF is reduced compared to the LDO Mode.

b) SREF is blocked against SGND with a 1 μF (+ optional 10 nF) capacitor and CF is blocked with a 1.0 μF capacitor. PSRR is improved regarding "a". The internal reference is VLDO/2.

Note: SREF can be used as reference input for external op amps, if no current load is applied. Keep the traces at SREF and CF as short as possible to avoid system noise pickup.

SGND (see Fig. 4–3):

Reference ground for the internal voltage reference and biasing circuits. This pin should be connected to a clean ground potential. Any external distortions on this pin will affect the analog performance of the DAC 3560C. SGND must be connected to AVSS.

4.3.4. Analog Audio Pins

AUXL, AUXR, AIN (see Fig. 4–8):

These pins provide analog stereo/mono inputs. Auxiliary input signals, e.g. the output of a conventional receiver circuit or the output of a tape recorder can be connected here. The input gain is programmable between –20 dB and +20 dB in steps of 2 dB. The input signals have to be connected by capacitive coupling. Each signal can be mixed to the output of the embedded DAC.

HPL, HPR, HPCM (see Fig. 4–9, Fig. 4–10):

The HPL/R pins are connected to the internal headphone drivers. They can be used for single-ended stereo headphones of greater or equal than 16 Ohm. There are two modes of applying the load:

1. Load to ground: Each channel must be coupled capacitively.
2. Load to HPCM: Channels can be coupled directly to HPCM. The common mode buffer at HPCM must be enabled before activating the drivers.

EPP, EPN (see Fig. 4–14):

The EPP/N pins are connected to the internal earpiece driver. They can be used for differential mono earpiece speakers of greater than, or equal to, 16 Ohm.

LSP, LSN (see Fig. 4–13):

The LSP/N pins are connected to the internal loudspeaker driver. They can be used for differential mono loudspeakers of greater or equal than 4 Ohm.

All analog outputs show a programmable gain range of –30 dB to +6 dB plus Mute.

Note: Any occurrence of a short circuit at pins HPL, HPR, HPCM, EPP, EPN may result in initialization of the built-in temperature protection unit, which turns off the output drivers. When the short-circuit condition is removed, the drivers will be turned on again. The pins LSP and LSN are not short-circuit-proof.

4.3.5. Digital Audio Input Pins

CLI, DAI, WSI (see Fig. 4–10):

These three pins are inputs for the digital audio data DAI, frame indication signal WSI, and bit clock CLI. The digital audio data is transmitted in an I²S-compatible format. Audio word lengths of 16 and 32 bits are supported, as well as SONY and Philips I²S protocol.

- Do not leave these pins unconnected!

4.3.6. Control Interface Pins

SCLK, SDI, SDO, MODE, \overline{CS} (see Fig. 4–10, Fig. 4–11, Fig. 4–12):

Two protocol control modes are possible:

1. I²C mode:
SCLK and SDI provide the connection to the serial control interface.
2. SPI mode:
Two additional signals are needed:
 \overline{CS} serves as the interface chip select.
SDO sends out data after a read command.

- MODE toggles between the two control modes.

4.3.7. Other Pins

\overline{RES} (see Fig. 4–10):

This pin may be used to reset the chip. After power-up it should be raised from DVSS potential to DVDD level. Signal function is active low.

-

4.4. Pin Configurations

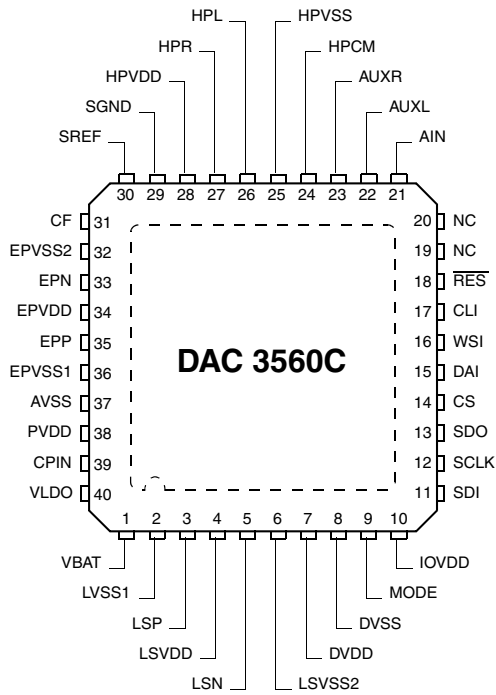

Fig. 4-3: PQFN40-1 package

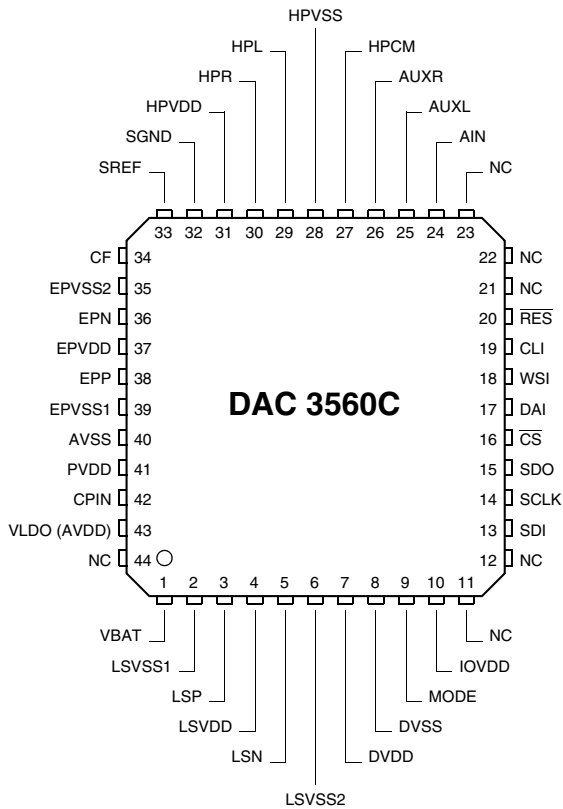

Fig. 4-4: PMQFP44-1 package

4.5. Pin Circuits

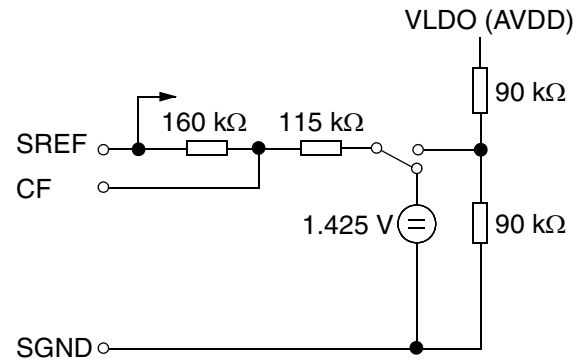

Fig. 4-5: Reference Pins: SREF, CF, SGND, VLDO

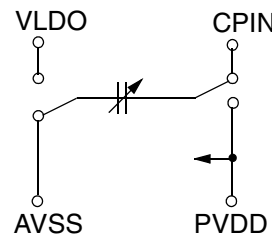

Fig. 4-6: Supply Pins: CPIN, PVDD

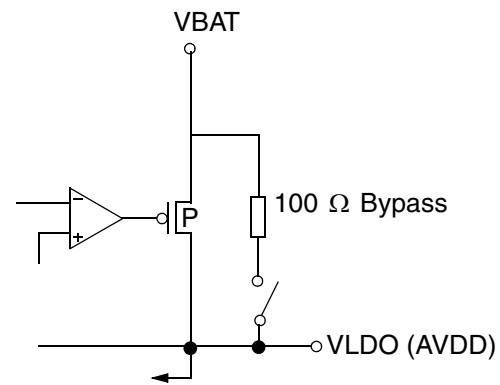

Fig. 4-7: Supply Pins: VLDO, VBAT

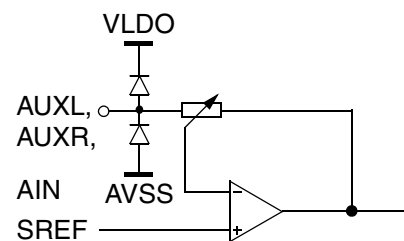

Fig. 4-8: Input Pins: AUXL, AUXR, AIN

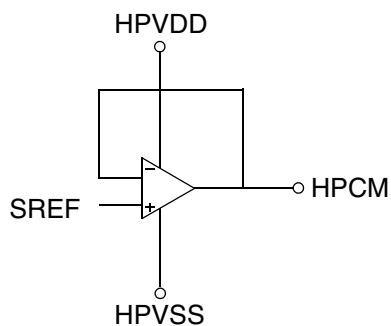

Fig. 4-9: Output Pin: HPCM

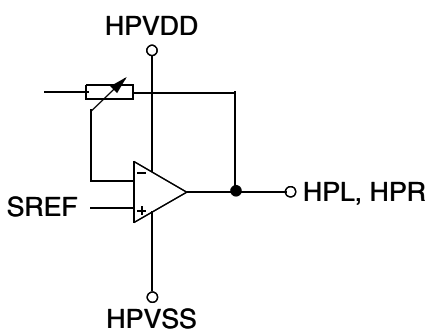

Fig. 4-10: Output Pins: HPL, HPR

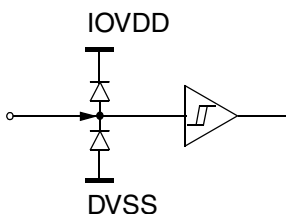

Fig. 4-11: Input Pins: Mode, \overline{CS} , DAI, WSI, CLI

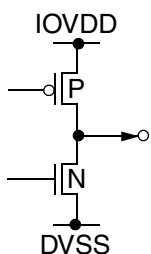

Fig. 4-12: Output Pin: SDO

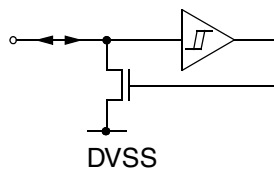

Fig. 4-13: Input/Output Pins: SDI, SCLK

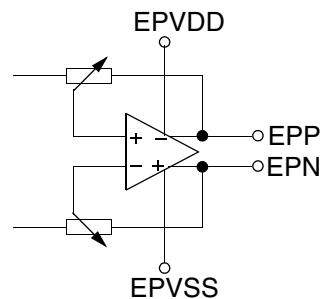

Fig. 4-14: Output Pins: EPP, EPN, EPVDD, EPVSS

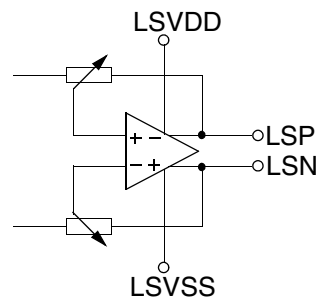

Fig. 4-15: Output Pins: LSP, LSN, LSVDD, LSVSS

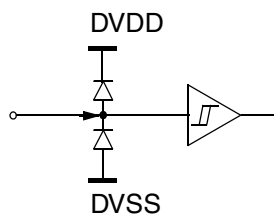

Fig. 4-16: Input pin \overline{RES}

4.6. Electrical Characteristics

Abbreviations:

- tbd = to be defined
- vacant = not applicable
- positive current values mean current flowing into the chip

4.6.1. Absolute Maximum Ratings

Stresses beyond those listed in the “Absolute Maximum Ratings” may cause permanent damage to the device. This is a stress rating only. Functional operation of the device at these conditions is not implied. Exposure to absolute maximum rating conditions for extended periods will affect device reliability.

This device contains circuitry to protect the inputs and outputs against damage due to high static voltages or electric fields; however, it is advised that normal precautions be taken to avoid application of any voltage higher than absolute maximum-rated voltages to this high-impedance circuit.

All voltages listed are referenced to ground ($V_{SUP} = 0\text{ V}$) except where noted.

All GND pins must be connected to a low-resistive ground plane close to the IC.

Symbol	Parameter	Pin Name	Limit Values		Unit
			Min.	Max.	
T_A ¹⁾	Ambient Operating Temperature PMQFP44-1 PQFN40-1		-40 -40	85 ²⁾ 85 ²⁾	°C °C
T_C	Case Operating Temperature – Operating Conditions: PMQFP44-1 PQFN40-1		-40 -40	120 100	°C °C
T_S	Storage Temperature		-40	125	°C
P_{MAX}	Maximum Power Dissipation PMQFP44-1 PQFN40-1			580 1100	mW mW
V_{SUP}	Supply Voltage	VBAT, LSVDD, VLDO, HPVDD, EPVDD, CPIN, DVDD, IOVDD	-0.3	6	V
V_{Iana}	Analog Input Voltages	AIN, AUXL, AUXR, SREF, CF	-0.3	VLDO+0.3	V

¹⁾ Measured on Micronas typical 2-layer (1s1p) board based on JESD - 51.2 Standard with maximum power consumption allowed for this package

²⁾ A power-optimized board layout is recommended. The Case Operating Temperature mentioned in the “Absolute Maximum Ratings” must not be exceeded at worst case conditions of the application.

Symbol	Parameter	Pin Name	Limit Values		Unit
			Min.	Max.	
V_{Idig}	Digital Input Voltages	MODE, SDO, SDI, SCLK, \overline{CS} , DAI, WSI, CLI,	-0.3	IOVDD+0.3	V
$V_{I\overline{RES}}$		\overline{RES}	-0.3	DVDD+0.3	V
V_{I2C}		SDI, SCLK	-0.3	6	V
I_{Iana}	Analog Input Currents	AIN, AUXL, CF, AUXR, SREF,	-5	5	mA
I_{Idig}	Digital Input Currents	MODE, SDO, SDI, SCLK, \overline{CS} , DAI, WSI, CLI, RES	-5	5	mA
I_{Odig}	Digital Output Currents	SDO, SDI, SCLK	-50	50	mA
I_{OLDO}	Analog Output Currents	LDO	internally limited	50	mA
I_{OHP}		HPL, HPR, HPCM		internally limited	mA
I_{OEP}		EPN, EPP			
I_{OLS}		LSP, LSN	tbd	tbd	

4.6.2. Recommended Operating Conditions

Functional operation of the device beyond those indicated in the “Recommended Operating Conditions/Characteristics” is not implied and may result in unpredictable behavior, reduce reliability and lifetime of the device.

All voltages listed are referenced to ground ($V_{SUP} = 0\text{ V}$) except where noted.

All GND pins must be connected to a low-resistive ground plane close to the IC.

Do not insert the device into a live socket. Instead, apply power by switching on the external power supply. For power up/down sequences, see the instructions in Section 5.3.1. of this document.

4.6.2.1. General Recommended Operating Conditions

Symbol	Parameter	Pin Name	Limit Values			Unit
			Min.	Typ.	Max.	
T_A	Ambient Operating Temperature PMQFP44-1, PQFN40-1 – Operating Conditions – Extended Temperature Range: ²⁾		0 –40		85 ¹⁾ 85	°C
T_C	Case Operating Temperature PMQFP44-1 PQFN40-1		0 0		105 95	°C °C
V_{SUPA1}	Analog Supply Voltage (Non-LDO mode) Charge pump: on	VBAT, LSVDD, VLDO, HPVDD, EPVDD, CPIN	2.2		3.4	V
	Analog Supply Voltage (Non-LDO mode) Charge pump: off		2.7		5.5	V
V_{SUPA2}	Analog Supply Voltage (LDO mode)	VBAT, LSVDD	3		5.5	V
V_{SUPD}	Digital Supply Voltage	DVDD	2.2		5.5	V
V_{SUPIO}	Digital Interface Voltage	IOVDD	1.8		5.5	V
C_{LDOout}	LDO Output Capacitor use Ceramic X7R, X5R	VLDO	0.8	1.0	1.3	μF
C_{LDOin}	LDO Input Capacitor	VBAT	0.47			μF
C_{Pout}	Charge Pump Output Capacitor	PVDD, VLDO		47		nF
C_{Ain}	Analog Input Coupling Capacitor	AUXL, AUXR, AIN	470			nF
C_{Sref}	SREF Bypass Capacitor	SREF	3.3			μF

¹⁾ A power-optimized board layout is recommended. The Case Operating Temperatures mentioned in the “Recommended Operating Conditions” must not be exceeded at worst case conditions of the application.

²⁾ Data sheet parameters are valid for “operating conditions” only. This product has been designed for and verified to the following temperature range: –40 °C to +85 °C. Design verification has been undertaken on silicon processed with a specialized parameter set in order to confirm robustness to standard production process variations.

continued...

Symbol	Parameter	Pin Name	Limit Values			Unit
			Min.	Typ.	Max.	
R _{LHP}	Headphone Load Resistance	HPL, HPR, HPCM	16	32		Ω
R _{LEP}	Earpiece Load Resistance	EPP, EPN	16	32		Ω
R _{LS}	Loudspeaker Load Resistance	LSP, LSN	4	8		Ω

4.6.3. Characteristics (LDO Mode)

Unless noted otherwise: LSVDD = VBAT = 3.6 V, EPVDD = HPVDD = CPIN = PVDD = VLDO = 2.85 V (LDO mode), T_A = 0 °C ... 85 °C. Typical values are at T_A = 25 °C.

Symbol	Parameter	Pin Name	Limit Values			Unit	Test Conditions
			Min.	Typ.	Max.		
POWER MANAGEMENT, LDO							
V _{LDO}	LDO Output Voltage in Operational Mode	VLDO	2.75	2.85	2.95	V	no load connected
V _{LDO}	LDO Output Voltage in Standby Mode		2.75	2.85	2.95	V	LDO not bypassed, no load connected
			VBAT			V	LDO bypassed with internal 100Ω switch, no load connected
V _{LDO}	LDO Output Voltage in Zero Power Mode		HIGH-Z			V	LDO not bypassed
			VBAT			V	LDO bypassed with internal 100Ω switch, no load connected
I _{LDO}	LDO Output Current				260	mA	
V _{Drop}	LDO Drop Out Voltage	VBAT, VLDO		80		mV	I _{load} = 100 mA
I _{Short}	LDO Short Circuit Current	VLDO		680		mA	VLDO = 0V, Standby or Operational Mode, LDO not bypassed
I _{SupTot}	Supply Current	VBAT, LSVDD, VLDO, EPVDD, HPVDD, CPIN, PVDD, IOVDD, DVDD			10	μA	Zero Power Mode
				170		μA	Standby Mode, LDO bypassed, HPCM-Output enabled
				350		μA	Standby Mode, LDO bypassed, HPCM-Output off
				450		μA	Standby Mode, LDO on, HPCM-Output enabled
				620		μA	Standby Mode, LDO on, HPCM-Output off
			See Table 4-1.				
T _{TS}	Thermal Shutdown Temperature		130	145	160	°C	
H _{TS}	Thermal Shutdown Hysteresis			20		°C	

Symbol	Parameter	Pin Name	Limit Values			Unit	Test Conditions
			Min.	Typ.	Max.		
ANALOG AUDIO INPUTS - AIN, AUXL, AUXR							
V _{AI1}	0 dB (Full Scale) Input Level	AIN, AUXL, AUXR		2.04		V _{pp}	Gains set to 0 dB
V _{AI2}	Input Clipping Level			2.85		V _{pp}	Gains set to -20 dB
RI	Input Resistance		9	12.5	16	kΩ	Gain = +20 dB
			50	69	83		Gain = 0 dB
			90	125	155		Gain = -20 dB
G _{AI}	Gain Setting Range			-20	20	dB	
d _{GAI}	Gain Step Size			±2		dB	
E _{GAI}	Gain Step Size Error		-0.2	0.2	dB		
ANALOG AUDIO OUTPUTS – HEADPHONE, EARPIECE, LOUDSPEAKER							
G _{AO}	Volume Range	HPL, HPR, EPP, EPN, LSP, LSN	-30		6	dB	
d _{GAO}	Volume Step Size			±1.5		dB	
E _{GAO}	Volume Step Size Error			-0.2	0.2	dB	
P _{HP}	Headphone Output Power	HPL, HPR, (HPCM)		25 (22)		mW	THD < 0.1%, f=1 kHz, R _L = 32 Ω
P _{EP}	Earpiece Output Power	EPP, EPN		100		mW	THD < 0.2%, f=1 kHz, R _L = 32 Ω (one channel)
P _{LS}	Loudspeaker Output Power	LSP, LSN		410		mW	THD < 1%, f=1 kHz, R _L = 8 Ω
I _{HPshort}	Headphone Short-circuit Current	HPL, HPR, HPCM, VLDO, AVSS	0.1	0.45		A	not tested
I _{EPshort}	Earpiece Short-circuit Current	EPP, EPN, VLDO, AVSS	0.15	0.5		A	not tested
REFERENCES							
V _{REF1}	Signal Reference Level	AIN, AUXL, AUXR HPL, HPR, HPCM, EPP, EPN derived from SREF		1.425		V	SREF settled
V _{OREF2}	Output Signal Reference Level	LSP, LSN		1.5		V	SREF settled
SIGNAL CHAINS – DYNAMIC PERFORMANCE							
F _{sample} = 48 kHz with 24-Bit data, Bandwidth = 20 Hz...22 kHz, Values in dB are unweighted, values in dBA are A-weighted.							
V _{AOHP}	0 dB (full scale) Output Level Headphone	HPL, HPR		2.04		V _{pp}	Gains, Volumes = 0 dB. No load connected.
V _{AOEP}	0 dB (full scale) Output Level Earpiece	EPP, EPN,		4.08		V _{pp}	Gains, Volumes = 0 dB. No load connected.
V _{AO LS}	0 dB (full scale) Output Level Loudspeaker	LSP, LSN		4.08		V _{pp}	Gains, Volumes = 0 dB. No load connected.

Symbol	Parameter	Pin Name	Limit Values			Unit	Test Conditions
			Min.	Typ.	Max.		
DR _{DA} DR _{HP}	Dynamic Range, Digital to Analog Out	HPL, HPR, (HPCM) , EPP, EPN, LSP, LSN		98 94		dBA dB	Digital to Headphone
DR _{DA} DR _{EP}				99 95		dBA dB	Digital to Earpiece
DR _{DA} DR _{LS}				99 95		dBA dB	Digital to Loudspeaker
DR _{AA} DR _{HP}	Dynamic Range, Analog to Analog Out	AIN, AUXL, AUXR, HPL, HPR, HPCM, EPP, EPN, LSP, LSN		98 94		dBA dB	Analog to Headphone, DAC off
DR _{AA} DR _{EP}				99 96		dBA dB	Analog to Earpiece, DAC and headphone off
DR _{AA} DR _{LS}				98 96		dBA dB	Analog to Loudspeaker, DAC and headphone off
THD _{HP}	THD+N	HPL, HPR, (HPCM)		-76 (-68)		dB	Headphone, R _L = 32 Ω, P _{OUT} = 15 mW
THD _{EP}		EPP, EPN		-69		dB	Earpiece, R _L = 32 Ω, P _{OUT} = 50 mW
THD _{LS}		LSP, LSN		-63		dB	Loudspeaker, R _L = 8 Ω, P _{OUT} = 200 mW
LM	Mute Level	HPL, HPR, (HPCM), EPP, EPN, LSP, LSN		-105		dB	Headphone, volumes muted, Earpiece, Loudspeaker
XTALK _{HP→LS}	Crosstalk	HPL, HPR, LSP, LSN		-115	-95	dB	Crosstalk Headphone to Loudspeaker
XTALK _{EP→LS}	Crosstalk	EPP, EPN, LSP, LSN		-110	-95	dB	Crosstalk Earpiece to Loudspeaker
XTALK _{LS→EP}	Crosstalk	LSP, LSN, EPP, EPN,		-110	-95	dB	Crosstalk Loudspeaker to Earpiece
XTALK _{HP} L↔R	Crosstalk	HPL, HPR,		-90	-80	dB	Crosstalk Headphone left ↔right, single-ending mode
PSRR _{HP}	PSRR	VBAT, HPL, HPR, (HPCM)	100	115		dB	Headphone, f = 1 kHz, VBAT > 3 V, including LDO-Isolation V _{RIPPLE,peak} = 0.25 V Zero-Audio Signal
PSRR _{EP}	PSRR	VBAT, EPP, EPN	100	110		dB	Earpiece, f = 1 kHz, VBAT > 3 V, including LDO-Isolation V _{RIPPLE,peak} = 0.25 V Zero-Audio Signal
PSRR _{LS}	PSRR	VBAT, LSP, LSN	80	95		dB	Loudspeaker, f = 1 kHz, VBAT > 3 V V _{RIPPLE,peak} = 0.25 V Zero-Audio Signal

4.6.4. Characteristics (Non-LDO Mode)

Unless noted otherwise: LSVDD = VBAT = EPVDD = HPVDD = CPIN = VLDO = 2.2 V to 5.5 V (Non-LDO mode), T_A = 0 °C to 85 °C. Typical values are at T_A = 25 °C.

Symbol	Parameter	Pin Name	Limit Values			Unit	Test Conditions
			Min.	Typ.	Max.		
POWER MANAGEMENT, LDO							
I _{SupTot}	Supply Current at 2.2 V	VBAT, LSVDD, VLDO, EPVDD, HPVDD, CPIN, PVDD, IOVDD, DVDD			10	μA	Zero Power Mode
				185		μA	Standby Mode, HPCM-Output enabled
				355		μA	Standby Mode, HPCM-Output off
I _{SupTot}	Supply Current at 5 V				10	μA	Zero Power Mode
				235		μA	Standby Mode, HPCM-Output enabled
				420		μA	Standby Mode, HPCM-Output off
ANALOG AUDIO INPUTS - AIN, AUXL, AUXR							
V _{AI1}	0 dB (Full Scale) Input Level	AIN, AUXL, AUXR		0.715 x V _{LDO}		V _{pp}	Gains set to 0 dB
V _{AI2}	Input Clipping Level			V _{LDO}		V _{pp}	Gains set to -20 dB
ANALOG AUDIO OUTPUTS – HEADPHONE, EARPIECE, LOUDSPEAKER							
P _{HP}	Headphone Output Power at 2.2 V	HPL, HPR, (HPCM)		12		mW	THD < 0.1%, f=1 kHz, R _L = 32 Ω
P _{EP}	Earpiece Output Power at 2.2 V	EPP, EPN		50		mW	THD < 0.2%, f=1 kHz, R _L = 32 Ω
P _{LS}	Loudspeaker Output Power at 2.2 V	LSP, LSN		170		mW	THD < 1%, f=1 kHz, R _L = 8 Ω
P _{HP}	Headphone Output Power at 5 V	HPL, HPR, (HPCM)		78		mW	THD < 0.1%, f=1 kHz, R _L = 32 Ω
P _{EP}	Earpiece Output Power at 5 V	EPP, EPN		300		mW	THD < 0.2%, f=1 kHz, R _L = 32 Ω
P _{LS}	Loudspeaker Output Power at 5 V	LSP, LSN		1.1		W	THD < 1%, f=1 kHz, R _L = 8 Ω
REFERENCES							
V _{OREF1}	Output Signal Reference Level	HPL, HPR, HPCM, EPP, EPN derived from SREF		V _{LDO} /2		V	SREF settled
V _{OREF2}	Output Signal Reference Level	LSP, LSN		V _{LDO} /2		V	SREF settled
SIGNAL CHAINS – DYNAMIC PERFORMANCE							
F _{sample} = 48 kHz with 24-Bit data, Bandwidth = 20 Hz...22 kHz, Values in dB are unweighted, values in dBA are A-weighted.							
V _{AOHP}	0 dB (Full scale) Output Level Headphone	HPL, HPR		0.715 x V _{LDO}		V _{pp}	Gains, Volumes = 0 dB. No load connected.

Symbol	Parameter	Pin Name	Limit Values			Unit	Test Conditions
			Min.	Typ.	Max.		
V _{AOEP}	0 dB (Full scale) Output Level Earpiece	EPP, EPN,		1.43 x V _{LDO}		V _{pp}	Gains, Volumes = 0 dB. No load connected.
V _{AO LS}	0 dB (Full scale) Output Level Loudspeaker	LSP, LSN		1.43 x V _{LDO}		V _{pp}	Gains, Volumes = 0 dB. No load connected.
DR _{DA} DR _{HP}	Dynamic Range, Digital to Analog Out at 2.2 V	HPL, HPR, (HPCM), EPP, EPN, LSP, LSN		96 93		dBA dB	Digital to Headphone
DR _{DA} DR _{EP}				98 94		dBA dB	Digital to Earpiece
DR _{DA} DR _{LS}				98 94		dBA dB	Digital to Loudspeaker
DR _{DA} DR _{HP}	Dynamic Range, Digital to Analog Out at 5 V			103 99		dBA dB	Digital to Headphone
DR _{DA} DR _{EP}				102 98		dBA dB	Digital to Earpiece
DR _{DA} DR _{LS}				94 91		dBA dB	Digital to Loudspeaker
DR _{AA} DR _{HP}	Dynamic Range, Analog to Analog Out at 2.2 V	AIN, AUXL, AUXR, HPL, HPR, HPCM, EPP, EPN, LSP, LSN		96 92		dBA dB	Analog to Headphone, DAC off
DR _{AA} DR _{EP}				98 94		dBA dB	Analog to Earpiece, DAC and headphone off
DR _{AA} DR _{LS}				95 92		dBA dB	Analog to Loudspeaker, DAC and headphone off
DR _{AA} DR _{HP}	Dynamic Range, Analog to Analog Out at 5 V			104 100		dBA dB	Analog to Headphone, DAC off
DR _{AA} DR _{EP}				103 99		dBA dB	Analog to Earpiece, DAC and headphone off
DR _{AA} DR _{LS}				94 91		dBA dB	Analog to Loudspeaker, DAC and headphone off
THD _{HP}	THD+N at 2.2 V	HPL, HPR		-71		dB	Headphone, R _L = 32 Ω, P _{OUT} = 8 mW
THD _{HP}		HPL, HPR, (HPCM)		-67		dB	Headphone + HPCM, R _L = 32 Ω, P _{OUT} = 8 mW
THD _{EP}		EPP, EPN		-69		dB	Earpiece, R _L = 32 Ω, P _{OUT} = 30 mW
THD _{LS}		LSP, LSN		-62		dB	Loudspeaker, R _L = 8 Ω, P _{OUT} = 130 mW
THD _{HP}	THD+N at 5 V	HPL, HPR		-82		dB	Headphone, R _L = 32 Ω, P _{OUT} = 50 mW
THD _{HP}		HPL, HPR, (HPCM)		-74		dB	Headphone + HPCM, R _L = 32 Ω, P _{OUT} = 50 mW
THD _{EP}		EPP, EPN		-76		dB	Earpiece, R _L = 32 Ω, P _{OUT} = 140 mW
THD _{LS}		LSP, LSN		-63		dB	Loudspeaker, R _L = 8 Ω, P _{OUT} = 600 mW
PSRR _{HP}	PSRR	VBAT, HPL, HPR, (HPCM)		68		dB	Headphone, f = 1 kHz,
PSRR _{EP}		VBAT, EPP, EPN		70		dB	Earpiece, f = 1 kHz
PSRR _{LS}		VBAT, LSP, LSN		70		dB	Loudspeaker, f = 1 kHz

4.6.5. Terminology

1. THD+N (dB): Total Harmonic Distortion+Noise: the ratio of the RMS values of Distortion+Noise within a certain bandwidth to the fundamental signal at a given output level or output power.
2. DR (dB): Dynamic Range: a measure of the difference between the highest and lowest part of a signal. Normally, it is a THD+N measurement with a sinusoidal input signal at a level of 60 dB below full scale. Adding the 60 dB to the result represents the dynamic range, for example:
THD+N at -60 dB = -35 dB, DR = 95 dB.
3. XTALK (dB) : Crosstalk : applying a full-scale signal to one input channel, while measuring every inactive input or output channel.

4.6.6. Digital Characteristics

4.6.6.1. I²C Bus Characteristics

Symbol	Parameter	Pin Name	Limit Values			Unit	Test Conditions
			Min.	Typ.	Max.		
V _{I2CIL}	I ² C BUS Input Low Voltage	SCLK, SDI			0.3	IOVDD	
V _{I2CIH}	I ² C BUS Input High Voltage		0.65			IOVDD	
t _{I2C1}	I ² C START Condition Setup Time		120			ns	
t _{I2C2}	I ² C STOP Condition Setup Time		120			ns	
t _{I2C5}	I ² C Data Setup Time before Rising Edge of Clock		55			ns	
t _{I2C6}	I ² C Data Hold Time after Falling Edge of Clock		55			ns	
t _{I2C3}	I ² C Clock Low Pulse Time	SCLK	500			ns	
t _{I2C4}	I ² C Clock High Pulse Time		500			ns	
f _{I2C}	I ² C BUS Frequency				1.0	MHz	
V _{I2COL}	I ² C Data Output Low Voltage	SCLK, SDI			0.4	V	I _{I2COL} = 3 mA
I _{I2COH}	I ² C Data Output High Leakage Current				1.0	μA	V _{I2COH} = 5 V
t _{I2COL1}	I ² C Data Output Hold Time after Falling Edge of Clock		15			ns	
t _{I2COL2}	I ² C Data Output Setup Time before Rising Edge of Clock		100			ns	f _{I2C} = 1 MHz

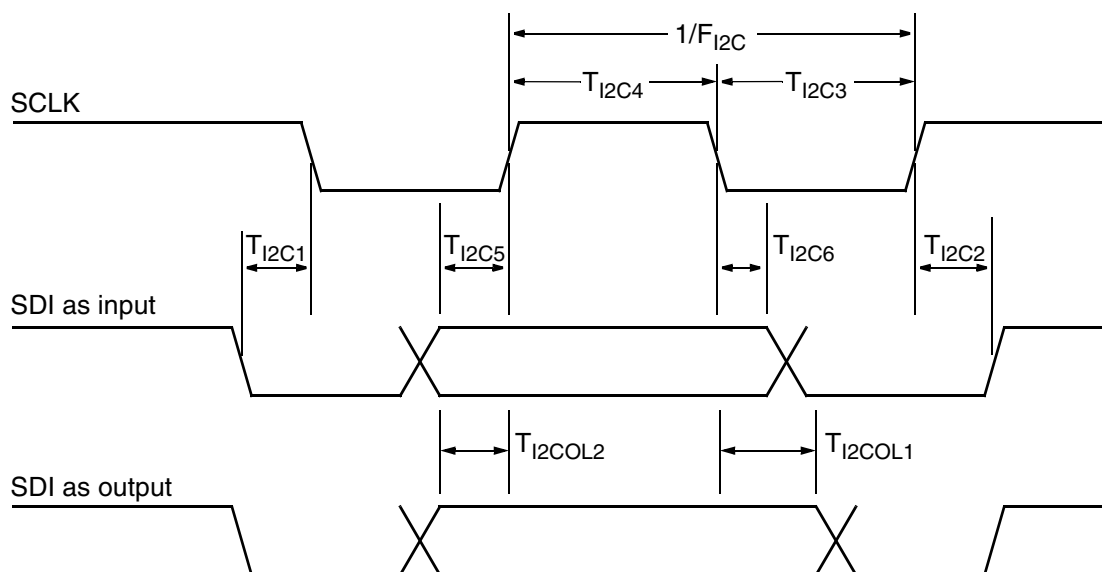
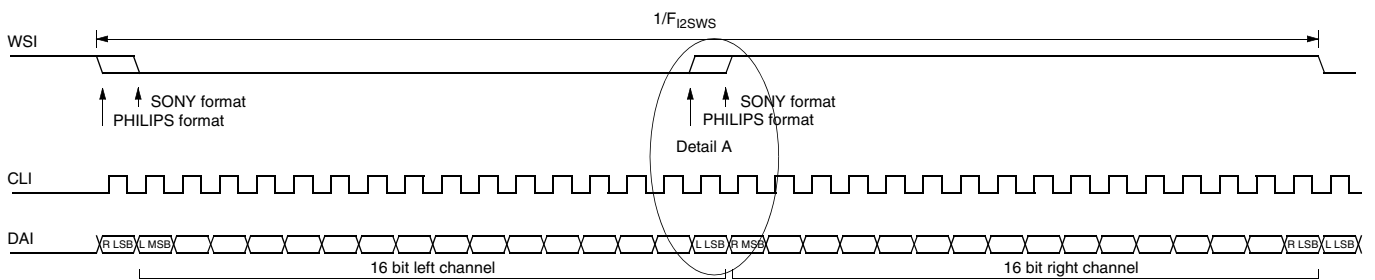

Fig. 4-17: I²C bus timing diagram

4.6.6.2. I²S Bus Characteristics

Symbol	Parameter	Pin Name	Min.	Typ.	Max.	Unit	Test Conditions
V _{I2SIL}	Input Low Voltage	DAI CLI WSI			0.2	IOVDD	
V _{I2SIH}	Input High Voltage		0.65			IOVDD	
Z _{I2SI}	Input Impedance				5	pF	
I _{LEAKI2S}	Input Leakage Current		-1		1	μA	0 V < U _{INPUT} < IOVDD
t _{I2S1}	I ² S Input Setup Time before Rising Edge of CLI	DAI WSI	10			ns	for details see Fig. 4-18 (I ² S interface)
t _{I2S2}	I ² S Input Hold Time after Rising Edge of CLI		20			ns	
R _{CLI}	I ² S Clock Input Ratio		0.9		1.1		
F _{CLI}	I ² S Clock Frequency	CLI,DAI			12.3	MHz	32 bit, F _{sample} = 192 kHz



Detail A

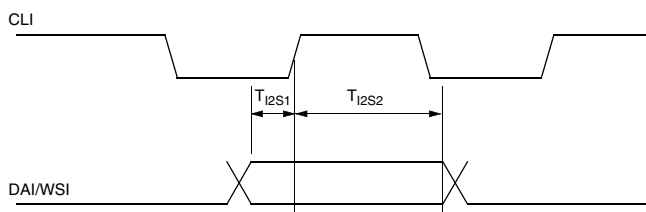

Fig. 4-18: I²S timing diagram

4.6.6.3. Reset Input Characteristics

Symbol	Parameter	Pin Name	Limit Values			Unit	Test Conditions
			Min.	Typ.	Max.		
$V_{I\overline{RES}}$	Input Low Voltage	\overline{RES}			0.2	DVDD	
$V_{I\overline{RES}}$	Input High Voltage		0.65			DVDD	
$Z_{I\overline{RES}}$	Input Impedance				5	pF	
$I_{\overline{RES}}$	Input Leakage Current		-1		1	μA	$0\text{ V} < U_{\text{INPUT}} < \text{DVDD}$

4.6.6.4. Mode Input Characteristics

Symbol	Parameter	Pin Name	Limit Values			Unit	Test Conditions
			Min.	Typ.	Max.		
$V_{I\text{MODE}}$	Input Low Voltage	MODE			0.2	IOVDD	
$V_{I\text{MODE}}$	Input High Voltage		0.65			IOVDD	
$Z_{I\text{MODE}}$	Input Impedance				5	pF	
$I_{I\text{MODE}}$	Input Leakage Current		-1		1	μA	$0\text{ V} < U_{\text{INPUT}} < \text{IOVDD}$

4.6.6.5. SPI-Bus Characteristics

Symbol	Parameter	Pin Name	Limit Values			Unit	Test Conditions
			Min.	Typ.	Max.		
V _{SPIIL}	Input Low Voltage	SDI SCLK CS			0.2	IOVDD	
V _{SPIIH}	Input High Voltage		0.65			IOVDD	
Z _{SPII}	Input Impedance				5	pF	
I _{LEAKSPI}	Input Leakage Current		-1		1	μA	0 V < U _{INPUT} < IOVDD
t _{SPI1}	SPI Input Setup Time before Rising Edge of SCLK	SDI \overline{CS}	10			ns	
t _{SPI2}	SPI Input Hold Time after Rising Edge of SCLK		40			ns	
R _{CLI}	SPI Clock Input Ratio		0.9		1.1		
V _{SPIOL}	SPI Output Low Voltage	SDO			0.4	V	I _{SPIOL} = 0.5 mA, IOVDD = 1.8 V
V _{SPIOH}	SPI Output High Voltage		1.2			V	I _{SPIOH} = -0.5 mA IOVDD = 1.8 V
f _{SCLK1}	SPI Clock Frequency, read access	SCLK, SDI, SDO			10	MHz	C _L = 20 pF, IOVDD = 3.3 V
					6	MHz	C _L = 20 pF, IOVDD = 1.8 V
f _{SCLK2}	SPI Clock Frequency, write access	SCLK, SDI			10	MHz	C _L = 20 pF, IOVDD = 3.3 V
				t	6	MHz	C _L = 20 pF, IOVDD = 1.8 V

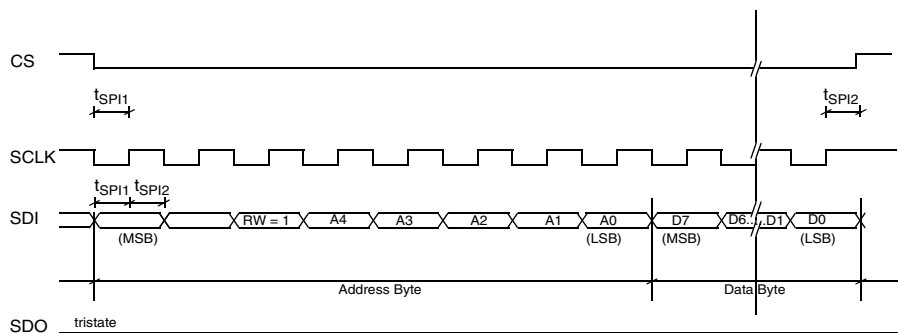

1. SPI write access

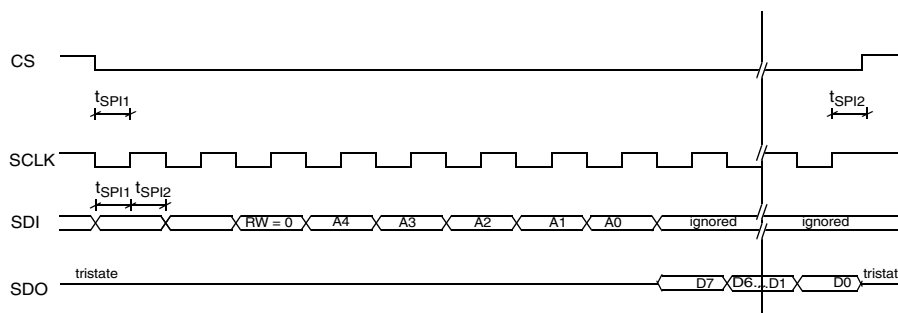

2. SPI read access

Fig. 4-19: SPI write and read access

4.6.7. Power Consumption (LDO Mode)

LSVDD=VBAT= 3.6 V, EPVDD=HPVDD=CPIN=PVDD=VLDO= 2.85 V, DVDD = 2.2 V, IOVDD = 1.8 V.
Typical Values, Operational Mode.

Table 4–1: Current Consumption Examples (Operational Mode)

Control Bits	A	B	C	D	E	F	G	H	I	Description
SMM			X	X	X	X				Select mono mode
PDAC	X	X	X	X					X	Power DAC
PAIN					X	X			X	Power AIN input
PAUX							X	X	X	Power AUX input
PL			X		X				X	Power Loudspeaker
PEP				X		X			X	Power Earpiece
PRH	X	X					X	X	X	Power Right Head- phone
PLH	X	X					X	X	X	Power Left Headphone
ENHPC		X						X	X	Enable Headphone Common Driver
Current Consumption										Unit
Analog ¹⁾	7.5	8.7	4.3	4.7	3.1	3.4	6.1	7.3	13	mA
DVDD ²⁾	0.7		0.3		0	0	0	0	0.7	mA
IOVDD ²⁾	< 10									μA
All figures are quiescent currents with zero audio signal, no load connected.										
¹⁾ Including all analog supply pins: VBAT, LSVDD, VLDO, EPVDD, HPVDD, CPIN, PVDD ²⁾ I ² S digital audio data received with f _{sample} = 48 kHz, 32-bit word length, CLI=3.072 MHz.										
A) Stereo D/A → Headphone L/R B) Stereo D/A → Headphone L/R + Headphone Common C) Mono D/A → Loudspeaker D) Mono D/A → Earpiece E) AIN → Loudspeaker F) AIN → Earpiece G) AUX → Headphone L/R H) AUX → Headphone L/R + Headphone Common I) All signal chains on, stereo mode										

5. Detailed Mode Description

The DAC 3560C features many modes of operation, which can be set for a targeted application using the internal registers. Also, some external components and pin-to-pin connections may differ from application to application – mainly depending on whether the internal LDO is used or not. A detailed description of these features is given below.

5.1. LDO Mode, Using the internal Low-Dropout Regulator

The SNLDOM-Function bit in the MODE Control Register controls the operation of the DAC 3560C with, or without, use of the internal LDO. The default setting selects the LDO mode. The LDO then delivers a stable 2.85 V at its output when the device is in Standby or Operational Mode. The signal reference level for the audio outputs is 1.425 V (Pin SREF) except for the loudspeaker output, which has a reference level of 1.5 V. The LDO is intended to supply the headphone and the earpiece driver. Connect the supply pins of these drivers (HPVDD, EPVDD) to the LDO output (VLDO). Also connect the pins from the charge pump (CPIN, PVDD) to the LDO output. The charge pump is disabled when the DAC 3560C is in LDO Mode. Using the LDO increases the PSRR of the headphone and earpiece outputs in respect to the battery line (VBAT) to more than 100 dB. The input voltage range for full performance of the LDO is 5.5 V to 3.0 V. Lowering the input voltage further will – depending on load – reduce the PSRR until the LDO is out of regulation.

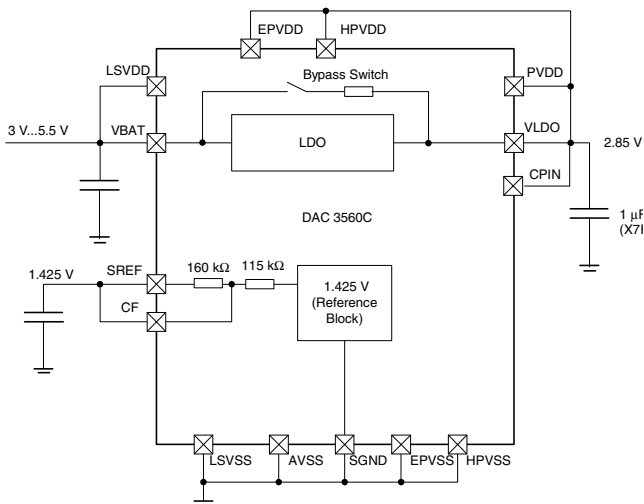

Fig. 5-1: Simplified application diagram using the DAC 3560C in LDO-Mode

The LDO output can be bypassed using the BYPLDO-Function bit in the MODE Control Register. Selecting this bit closes an internal 100 Ω switch between the LDOs input and output pin. This function is only available in Zero Power and Standby Mode. The LDO is then turned off. Use this function to reduce the quiescent current in Standby Mode.

5.2. Non-LDO Mode, Using the DAC 3560C without the LDO

Selecting the SNLDOM-Function Bit in the MODE Control Register disables the LDO and configures the DAC 3560C for a supply voltage range from 2.2 V to 5.5 V. The signal reference level for the audio outputs is formed by a resistive voltage divider to VBAT/2. A second filter capacitor can be connected to pin CF to form a second order noise filter. Connect the LDO output pin (VLDO) directly to the battery line (VBAT) as well as the supply pins of the audio drivers (HPVDD EPVDD, LSVDD) and the charge pump input (CPIN).

When using the LDO, connect a 1 µF ceramic capacitor (X7R, X5R) to the LDO output to ensure a stable operation of the LDO.

The DAC 3560C uses an internal charge pump circuit to keep internal circuits operating at low supply voltages. The charge pump must be used if the supply voltage at VBAT is below 2.7 V. Connect an additional capacitor between pin PVDD and pin VLDO to allow the internal charge pump to work properly.

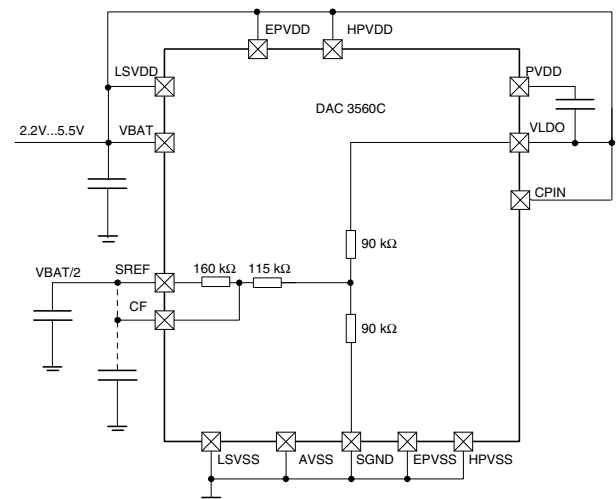

Fig. 5-2: Simplified application diagram using the DAC 3560C in Non-LDO-Mode

5.3. Headphone Common Driver

The DAC 3560C has driver outputs for earpiece, loudspeaker and headphone connection. While the earpiece and loudspeaker outputs are of the differential type, the headphone driver outputs are single-ended. Single-ended drivers usually require a large coupling capacitor to block the DC bias from the headphone. The DAC 3560C provides a headphone common output (HPCM), which eliminates the need for bulky DC-blocking capacitors.

Selecting the ENHPC-Bit in the BLOCK Control Register enables the headphone common driver output (HPCM). The HPCM-driver is then turned on with the left or right headphone and delivers the audio signal reference level at the output (1.425 V or VLDO/2).

Capacitive coupling is also possible for all driver outputs. Make sure that the ENHPC-Bit in the BLOCK Control Register is set correctly before setting the device in Standby or Operational Mode, otherwise the DAC 3560C might fail to bias DC-blocking capacitors at the headphone outputs.

Selecting the SMM-Function Bit in the MODE Control Register configures the DAC 3560C for mono or stereo operation.

Selecting mono mode will turn off the right DAC-channel. The I²S audio data format is still the same as for stereo operation but right channel audio data are dropped internally. The right headphone driver will be routed to the left signal chain. Use the Mono Mode to reduce the current consumption if no stereo signal processing is required.

For both modes, stereo or mono, the DAC 3560C supports side tone mixing from the auxiliary inputs (AUXL, AUXR, AIN). It is also possible to use the DAC 3560C without digital audio from the DAC, if only an analog-in to analog-out function is needed. See Table 5–1 for side tone capabilities of the DAC 3560C. Please also refer to the functional block diagram (see Fig. 1–1 on page 5), to see how audio signals are mixed.

Table 5–1: Mixing Possibilities: All Audio Inputs/Outputs active. Volumes, Gains set to 0 dB

Output	Stereo Mode	Mono Mode
Left Headphone Output	Ain + AuxL + DacL	Ain + (AuxL+AuxR)/2 + DacL
Right Headphone Output	Ain + AuxR + DacR	Ain + (AuxL+AuxR)/2 + DacL
Loudspeaker Output	Ain + (AuxL+AuxR)/2 + (DacL+DacR)/2	Ain + (AuxL+AuxR)/2 + DacL
Earpiece Output	Ain + (AuxL+AuxR)/2 + (DacL+DacR)/2	Ain + (AuxL+AuxR)/2 + DacL

Note: Please note that the sum of all input signals (DAC, AUX, AUXR, AIN), must not exceed the 0 db (Full Scale Level), otherwise signal degradation will occur due to clipping.

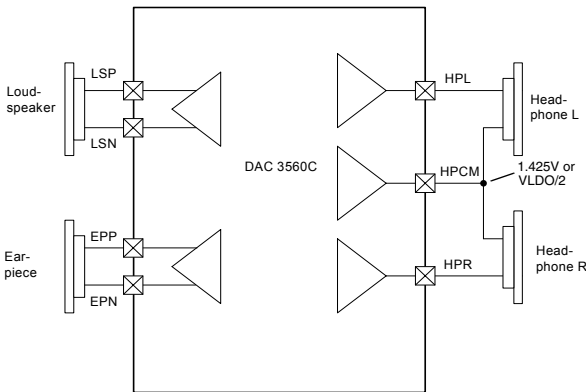

Fig. 5–3: Headphone connection, using the headphone common driver output

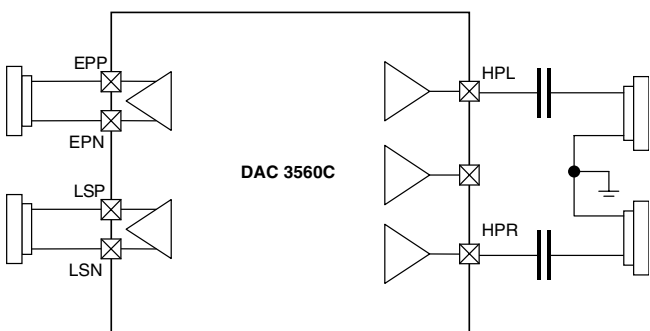

Fig. 5–4: Headphone connection by capacitive coupling

5.3.1. Digital Supply

The DAC 3560C has two supply pins for the digital part of the IC. The IOVDD Pin supplies the digital I/O cells, except the \overline{RES} input. The usable voltage range is 1.8 V to 5.5 V, allowing direct connection to modern microcontrollers. Pin DVDD supplies the internal digital core of the IC and the \overline{RES} input (see Fig. 4–16 on page 21) and (see Fig. 6–1 on page 39) Application Circuit. Make sure that DVDD is always available first or simultaneously with the other supply lines, in order to allow a proper reset. Do not connect IOVDD or DVDD to the LDO-Output when using the LDO, as this will result in a deadlock situation for the DAC 3560C.

5.3.2. Power On/Off Sequence

The DAC 3560C has three power states – Zero Power, Standby and Operational Mode, that permit powering on the device without clicks and pops, while giving the lowest current consumption possible. The power states of the DAC 3560C are controlled by function bits PM[1:0] in the Mode Control Register, selectable via the I²C/SPI control interface.

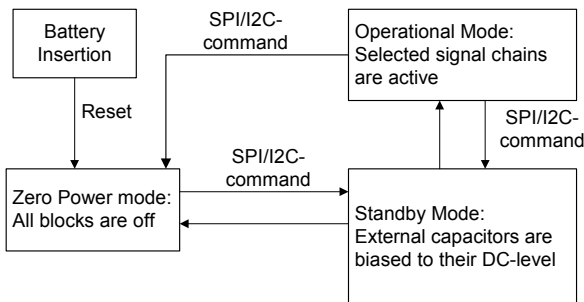

Fig. 5–5: Power states

Zero Power Mode:

When the battery voltage is initially applied, the DAC 3560C must be reset with a low signal at Pin \overline{RES} , in order to clear all internal registers to their default values, which sets the DAC 3560C into a defined state (Zero Power Mode).

In Zero Power Mode, all blocks are forced off and the current consumption of the device is zero.

After releasing the \overline{RES} pin, it is possible to program all registers of the DAC 3560C. However, all register contents are suppressed except the BYPLDO-function bit from the Mode Control Register, which allows bypassing the LDO output with an internal 100 Ω switch to VBAT. The following bits:

- SNLDM: (For using the device with or without the LDO)
- ENHPC: (For using or not using the headphone common driver)

should be set before entering the next power state (Standby Mode).

Standby Mode:

In Standby Mode, external capacitors are biased to their DC level (signal reference level). Only circuitries to bias the external capacitors are enabled, resulting in a low-current consumption.

Allow the signal reference level (Pin SREF, CF) to settle before changing to Operational Mode.

If the LDO is enabled (bit SNLDM=0) it delivers a stable 2.85 V at the output (VLDO). Bypassing the LDO with an internal 100 Ω switch to VBAT is also possible. The LDO is then disabled. Use this function to reduce the quiescent current in Standby Mode.

All registers are programmable during Standby Mode, but the content of the Block Control register is suppressed. It is recommended to keep all output volumes in their mute position before changing to Operational Mode in order to avoid audible clicks and pops.

Operational Mode:

In Operational Mode, the content of the Block Control register will become transparent, so that all selected blocks and their signal chains are active.

Programming all registers is possible allowing changing signal paths on the fly. However, it is recommended to ramp down the output volumes before, in order to avoid audible clicks and pops.

Power-Down Sequence:

Powering down the DAC 3560C from Operational Mode or Standby Mode can be achieved by selecting Zero Power Mode from the Mode Register. All register values remain unchanged. It is possible to clear all register values to their default values by a write access to the RESET Register.

6. Application Circuit

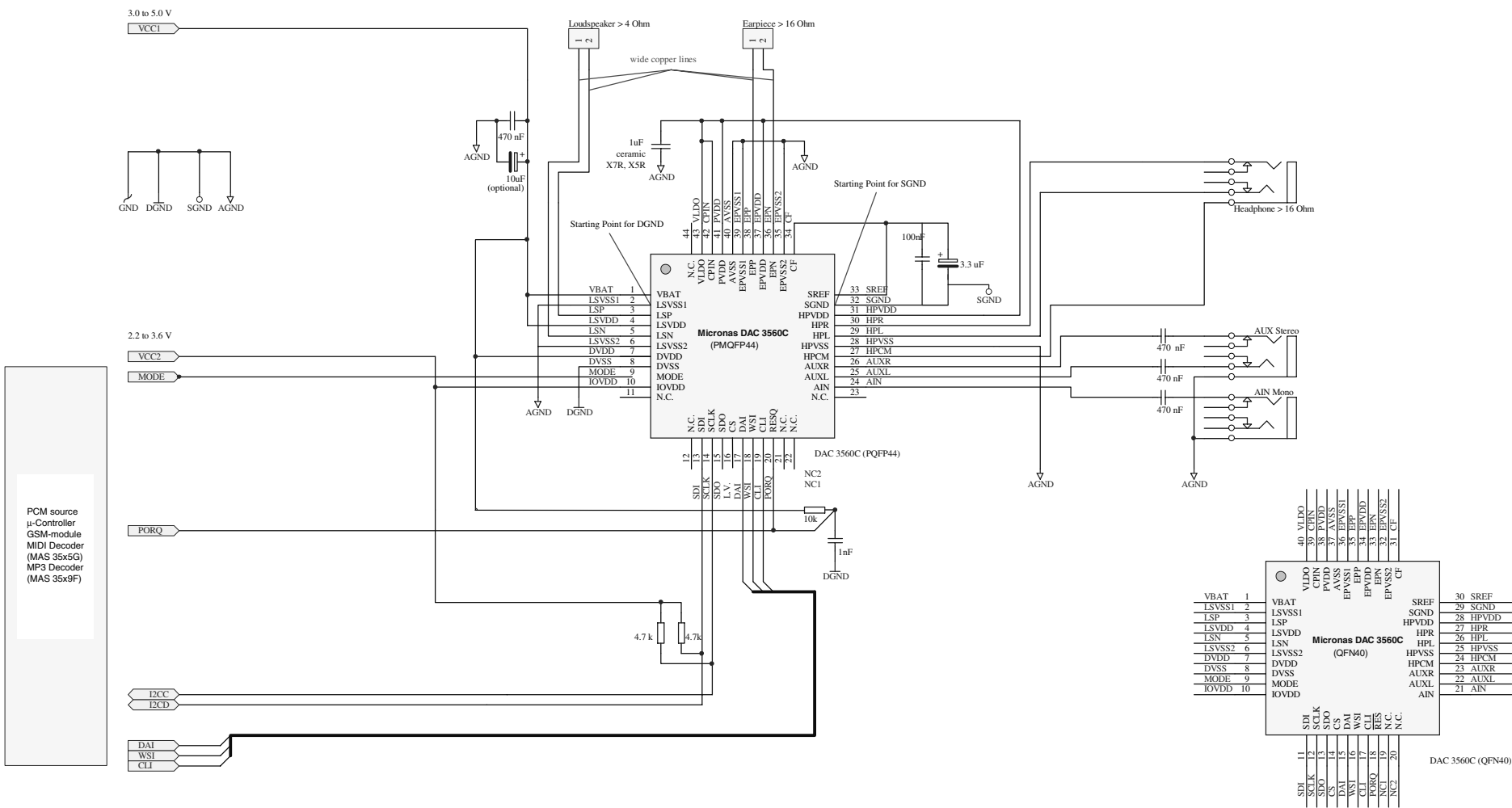

Fig. 6-1: Application circuit in LDO Mode, I²C Control

6.1. Suggestions for System Debugging

The goal of designing a bug-free system requires a systematic approach.

One important task is to prepare the right test points, so that debugging is easier or possible at all. If the chosen package is of the BGA- or QFN-type, the suggestions here become strong rules.

The signals listed below represent the most important interface and power signals.

They must be connected to test points on the circuit board, which allow the measurement with at least an oscilloscope's probe.

DVDD, IOVDD, HPVDD, EPVDD, LSVDD, PVDD,
VLDO, SREF

MODE, $\overline{\text{CS}}$

Some signals, such as I²C Control bus or digital Audio I²S bus, must be equipped with solderable points or routed to connectors, so that a protocol can be analyzed.

SCLK, SDI, SDO
CLI, WSI, DAI

The RESET pin of a chip plays an important role, especially its rising edge timing-position in relation to the rising of the VDD. The possibility to detach it from the board and provide a different timing for test purposes can lead to fast debug results.

$\overline{\text{RES}}$

Micronas encourages every system designer to take advantage of our experience.

7. Data Sheet History

1. Preliminary Data Sheet: "DAC 3560C Audio-Sub-system for Portable Applications", May 7, 2004, 6251-588-1PD. First release of the preliminary data sheet. Major changes:
 - Specification for PMQFP44-1 package added.
 - New package diagrams for PMQFP44-1 and PQFN40-1
 - Correction in application circuit.
2. Preliminary Data Sheet: "DAC 3560C Audio-Sub-system for Portable Applications", Sept. 8, 2004, 6251-588-2PD. Second release of the preliminary data sheet. Major changes:
 - Section 4.6. "Electrical Characteristics" corrected
 - Section 6.1. "Suggestions for System Debugging" added

Micronas GmbH
Hans-Bunte-Strasse 19
D-79108 Freiburg (Germany)
P.O. Box 840
D-79008 Freiburg (Germany)
Tel. +49-761-517-0
Fax +49-761-517-2174
E-mail: docservice@micronas.com
Internet: www.micronas.com

Printed in Germany
Order No. 6251-588-2PD

All information and data contained in this data sheet are without any commitment, are not to be considered as an offer for conclusion of a contract, nor shall they be construed as to create any liability. Any new issue of this data sheet invalidates previous issues. Product availability and delivery are exclusively subject to our respective order confirmation form; the same applies to orders based on development samples delivered. By this publication, Micronas GmbH does not assume responsibility for patent infringements or other rights of third parties which may result from its use.

Further, Micronas GmbH reserves the right to revise this publication and to make changes to its content, at any time, without obligation to notify any person or entity of such revisions or changes.

No part of this publication may be reproduced, photocopied, stored on a retrieval system, or transmitted without the express written consent of Micronas GmbH.