



T-45-19-05

SP8685A&B

500MHz ÷ 10/11

The SP8685 is an ECL variable modulus divider, with ECL 10K compatible outputs. It divides by 10 when either of the ECL control inputs, PE1 or PE2, is in the high state and by 11 when both are low (or open circuit).

FEATURES

- Divides by 10 and 11
- AC Coupled Input (Internal Bias)
- ECL Compatible Output

QUICK REFERENCE DATA

- Supply Voltage: -5.2V
- Power Consumption: 300mW
- Temperature Range:
 - 55°C to +125°C (A Grade)
 - 30°C to +70°C (B Grade)

ABSOLUTE MAXIMUM RATINGS

| | |
|---------------------------|-----------------|
| Supply voltage | -8V |
| Output current | 20mA |
| Storage temperature range | -55°C to +150°C |
| Max. junction temperature | +175°C |
| Max. clock I/P voltage | 2.5V p-p |

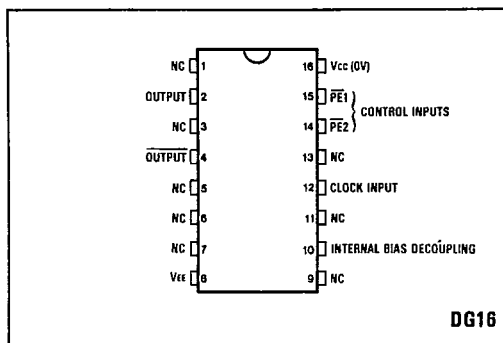

Fig.1 Pin connections - top view

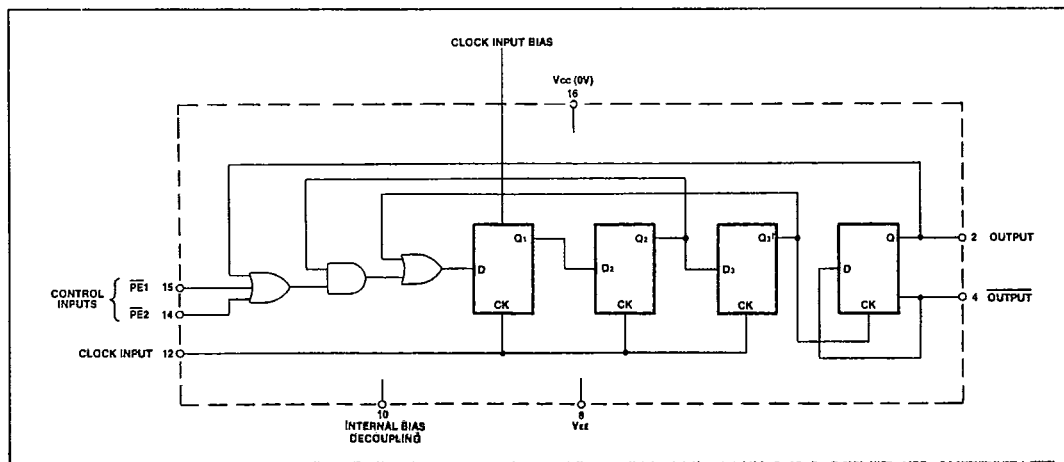

Fig.2 Functional diagram

ELECTRICAL CHARACTERISTICS

Supply Voltage: $V_{CC} = 0V$ $V_{EE} = -5.2V \pm 0.25V$
 Temperature: A Grade $T_{amb} = -55^{\circ}C$ to $+125^{\circ}C$
 B Grade $T_{amb} = -30^{\circ}C$ to $+70^{\circ}C$

| Characteristic | Symbol | Value | | Units | Conditions | Notes |
|------------------------------------|-----------|-------|-------|-------|-------------------------|--------|
| | | Min. | Max. | | | |
| Maximum frequency (sinewave input) | f_{max} | 500 | | MHz | Input = 400-800mV p-p | |
| Minimum frequency (sinewave input) | f_{min} | | 50 | MHz | Input = 400-800mV p-p | Note 6 |
| Power supply current | I_{EE} | | 70 | mA | $V_{EE} = -5.2V$ | Note 6 |
| Output high voltage | V_{OH} | -0.87 | -0.7 | V | $V_{EE} = -5.2V$ (25°C) | |
| Output low voltage | V_{OL} | -1.8 | -1.5 | V | $V_{EE} = -5.2V$ (25°C) | |
| \overline{PE} input high voltage | V_{INH} | -0.93 | | V | $V_{EE} = -5.2V$ (25°C) | |
| \overline{PE} input low voltage | V_{INL} | | -1.62 | V | $V_{EE} = -5.2V$ (25°C) | |
| Clock to output delay | t_p | | 6 | ns | | Note 7 |
| Set-up time | t_s | 2 | | ns | | Note 7 |
| Release time | t_r | 2 | | ns | | Note 7 |

NOTES

1. Unless otherwise stated, the electrical characteristics shown above are guaranteed over specified supply, frequency and temperature range.
2. The temperature coefficient of $V_{OH} = +1.63mV/^{\circ}C$, $V_{OL} = +0.94mV/^{\circ}C$ and of $V_{IN} = +1.22mV/^{\circ}C$ but these are not tested.
3. The test configuration for dynamic testing is shown in Fig.6.
4. The set up time t_s is defined as minimum time that can elapse between L \rightarrow H transition of control input and the next L \rightarrow H clock pulse transition to ensure that +10 is obtained.
5. The release time t_r is defined as the minimum time that can elapse between H \rightarrow L transition of the control input and the next L \rightarrow H clock pulse transition to ensure that the +11 mode is obtained.
6. Tested at 25°C only.
7. Guaranteed but not tested.

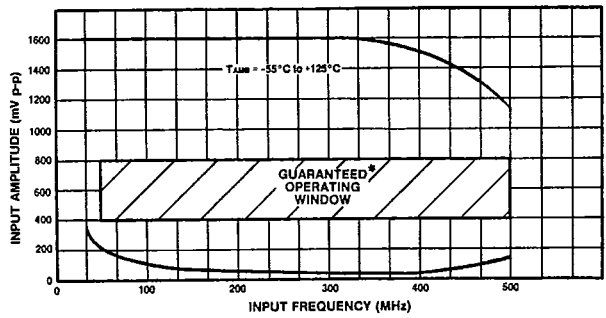

Fig.3 Typical input characteristic SP8685A

*Tested as specified in table of Electrical Characteristics

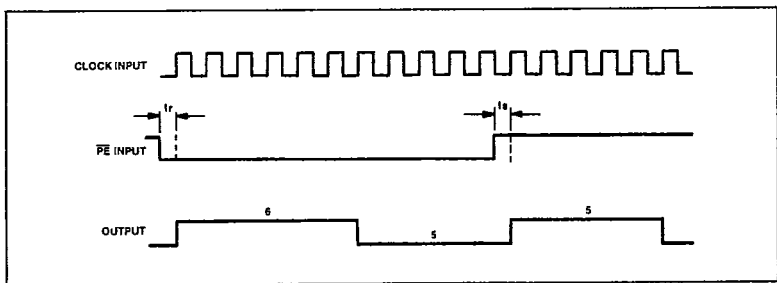

Fig.4 Timing diagram

T-45-19-05

OPERATING NOTES

1. The clock input is biased internally and is coupled to the signal source with a suitable capacitor. The input signal path is completed by an input reference decoupling capacitor which is connected to earth.
2. If no signal is present the device will self-oscillate. If this is undesirable it may be prevented by connecting a 15k resistor from clock input (Pin 12) to V_{EE} . This will reduce the input sensitivity by approximately 100mV.
3. The circuit will operate down to DC but slew rate must be better than 100V/ μ s.
4. The outputs are compatible with ECL II but can be interfaced to ECL 10K as shown in Fig.7.
5. The \overline{PE} inputs are ECL III/10K compatible and include a 4.3k internal pulldown resistor. Unused inputs can therefore be left open.

TRUTH TABLE FOR CONTROL INPUTS

| $\overline{PE1}$ | $\overline{PE2}$ | Division Ratio |
|------------------|------------------|----------------|
| L | L | 11 |
| H | L | 10 |
| L | H | 10 |
| H | H | 10 |

6. Input impedance is a function of frequency. See Fig. 5.
7. All components should be suitable for the frequency in use.

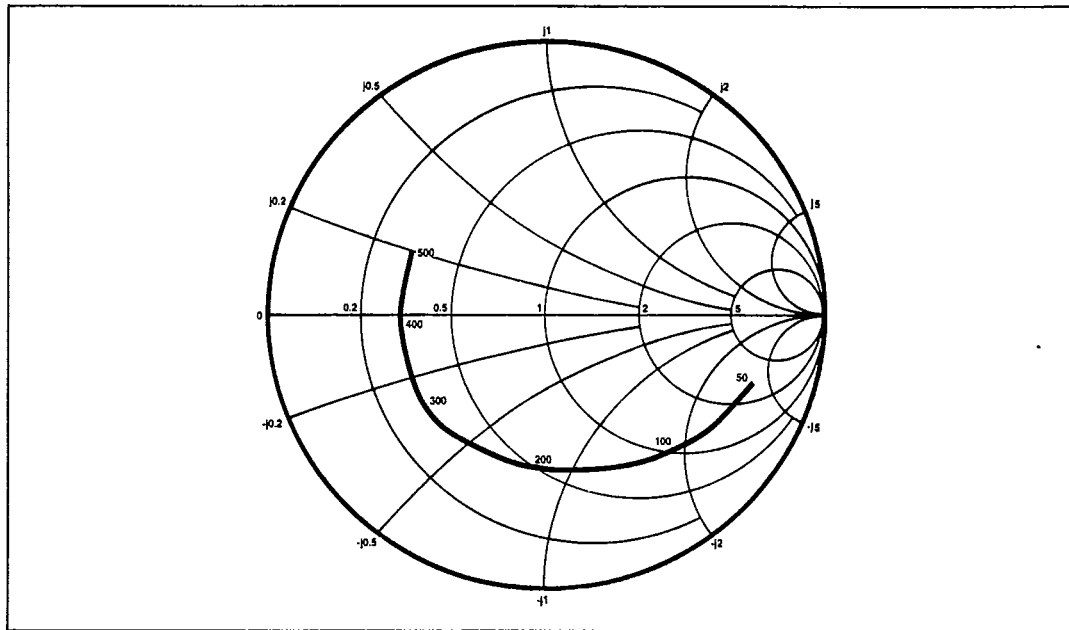

Fig.5 Typical input impedance. Test conditions: supply voltage -5.2V, ambient temperature 25°C, frequencies in MHz, impedances normalised to 50 ohms.

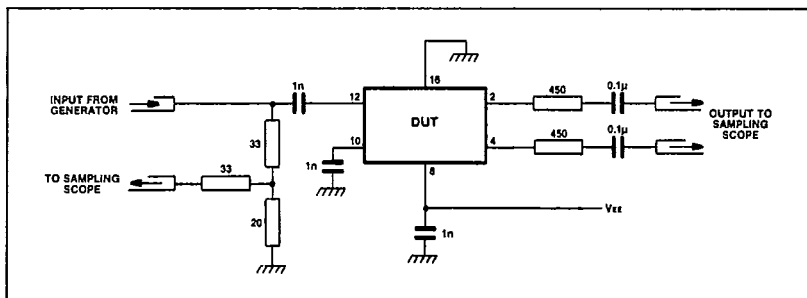

Fig.6 Test circuit

SP8685A & B

PLESSEY SEMICONDUCTORS

T-45-19-05

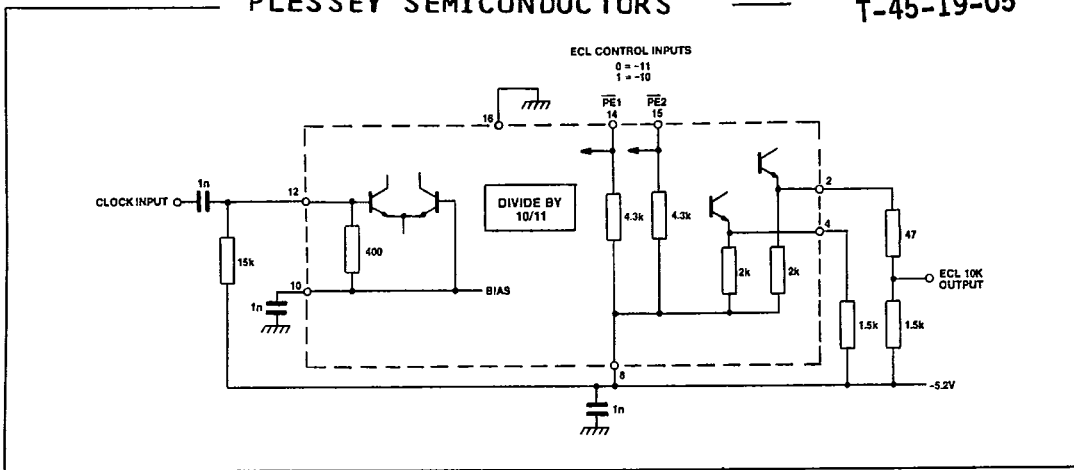

Fig.7 Typical application showing interfacing