



# Switched-Capacitor Voltage Inverters

MAX828/MAX829

## General Description

The ultra-small MAX828/MAX829 monolithic, CMOS charge-pump inverters accept input voltages ranging from +1.5V to +5.5V. The MAX828 operates at 12kHz, and the MAX829 operates at 35kHz. Their high efficiency (greater than 90% over most of the load-current range) and low operating current (60 $\mu$ A for the MAX828) make these devices ideal for both battery-powered and board-level voltage-conversion applications.

The MAX828/MAX829 combine low quiescent current and high efficiency. Oscillator control circuitry and four power MOSFET switches are included on-chip. Applications include generating a -5V supply from a +5V logic supply to power analog circuitry. Both parts come in a 5-pin SOT23-5 package and can deliver 25mA with a voltage drop of 500mV.

For applications requiring more power, the MAX860 delivers up to 50mA with a voltage drop of 600mV, in a space-saving  $\mu$ MAX package.

## Applications

- Small LCD Panels
- Cell Phones
- Medical Instruments
- Handy-Terminals, PDAs
- Battery-Operated Equipment

## Typical Operating Circuit

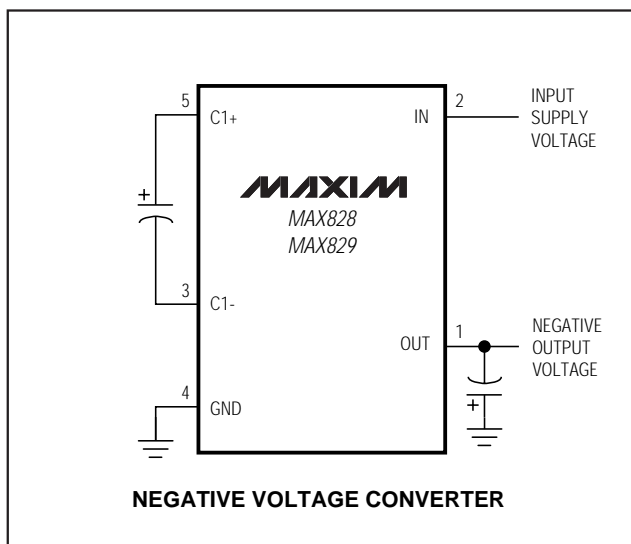

## Features

- ◆ 5-Pin SOT23-5 Package
- ◆ 95% Voltage Conversion Efficiency
- ◆ Inverts Input Supply Voltage
- ◆ 60 $\mu$ A Quiescent Current (MAX828)
- ◆ +1.5V to +5.5V Input Voltage Range
- ◆ Requires Only Two Capacitors
- ◆ 25mA Output Current

## Ordering Information

PART	TEMP. RANGE	PIN-PACKAGE	SOT TOP MARK
MAX828C/D	0°C to +70°C	Dice*	—
MAX828EUK	-40°C to +85°C	5 SOT23-5	AABI
MAX829C/D	0°C to +70°C	Dice*	—
MAX829EUK	-40°C to +85°C	5 SOT23-5	AABJ

\* Dice are tested at  $T_A = +25^\circ\text{C}$ .

## Pin Configuration

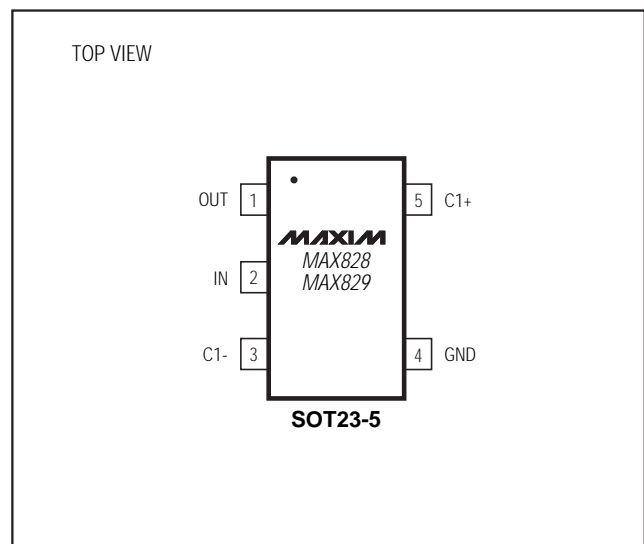

# Switched-Capacitor Voltage Inverters

## ABSOLUTE MAXIMUM RATINGS

IN to GND .....+6.0V, -0.3V  
 OUT to GND .....-6.0V, +0.3V  
 OUT Output Current .....50mA  
 OUT Short-Circuit to GND .....Indefinite  
 Continuous Power Dissipation (T<sub>A</sub> = +70°C)  
   SOT23-5 (derate 7.1mW/°C above +70°C).....571mW

Operating Temperature Range  
 MAX828EUK/MAX829EUK .....-40°C to +85°C  
 Storage Temperature Range .....-65°C to +160°C  
 Lead Temperature (soldering, 10sec) .....+300°C

*Stresses beyond those listed under "Absolute Maximum Ratings" may cause permanent damage to the device. These are stress ratings only, and functional operation of the device at these or any other conditions beyond those indicated in the operational sections of the specifications is not implied. Exposure to absolute maximum rating conditions for extended periods may affect device reliability.*

## ELECTRICAL CHARACTERISTICS

(V<sub>IN</sub> = +5V, C<sub>1</sub> = C<sub>2</sub> = 10μF (MAX828), C<sub>1</sub> = C<sub>2</sub> = 3.3μF (MAX829), T<sub>A</sub> = 0°C to +85°C, unless otherwise noted. Typical values are at T<sub>A</sub> = +25°C.)

PARAMETER	CONDITIONS		MIN	TYP	MAX	UNITS
Supply Current	T <sub>A</sub> = +25°C	MAX828		60	90	μA
		MAX829		150	260	
Minimum Supply Voltage	R <sub>LOAD</sub> = 10kΩ	T <sub>A</sub> = +25°C	1.25	1.0		V
		T <sub>A</sub> = 0°C to +85°C	1.5			
Maximum Supply Voltage	R <sub>LOAD</sub> = 10kΩ				5.5	V
Oscillator Frequency	T <sub>A</sub> = +25°C	MAX828	8.4	12	15.6	kHz
		MAX829	24.5	35	45.5	
Power Efficiency	R <sub>LOAD</sub> = 10kΩ, T <sub>A</sub> = +25°C			98		%
Voltage Conversion Efficiency	R <sub>LOAD</sub> = ∞		95	99.9		%
Output Resistance	I <sub>OUT</sub> = 5mA	T <sub>A</sub> = +25°C		20	50	Ω
		T <sub>A</sub> = 0°C to +85°C			65	

**Note 1:** Capacitor contribution is approximately 20% of the output impedance [ESR + 1 / (pump frequency x capacitance)].

## ELECTRICAL CHARACTERISTICS

(V<sub>IN</sub> = +5V, C<sub>1</sub> = C<sub>2</sub> = 10μF (MAX828), C<sub>1</sub> = C<sub>2</sub> = 3.3μF (MAX829), T<sub>A</sub> = -40°C to +85°C, unless otherwise noted. Typical values are at T<sub>A</sub> = +25°C.) (Note 2)

PARAMETER	CONDITIONS	MIN	TYP	MAX	UNITS
Supply Current	MAX828			115	μA
	MAX829			325	
Supply Voltage Range	R <sub>LOAD</sub> = 10kΩ	1.5		5.5	V
Oscillator Frequency	MAX828	6		20	kHz
	MAX829	19		54.3	
Output Resistance	I <sub>OUT</sub> = 5mA			65	Ω

**Note 2:** All -40°C to +85°C specifications above are guaranteed by design.

# Switched-Capacitor Voltage Inverters

## Typical Operating Characteristics

(Circuit of Figure 1,  $V_{IN} = +5V$ ,  $C1 = C2 = C3$ ,  $T_A = +25^\circ C$ , unless otherwise noted.)

MAX828/MAX829

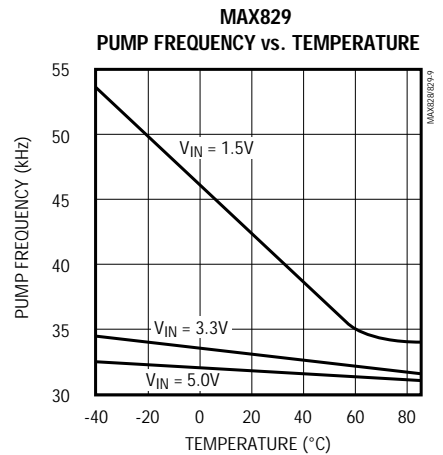
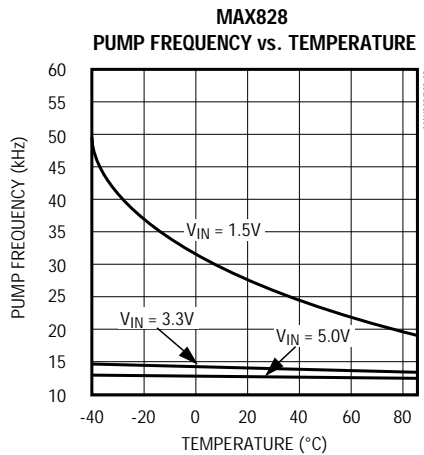
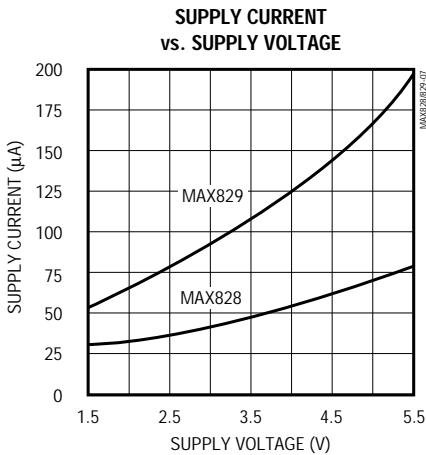
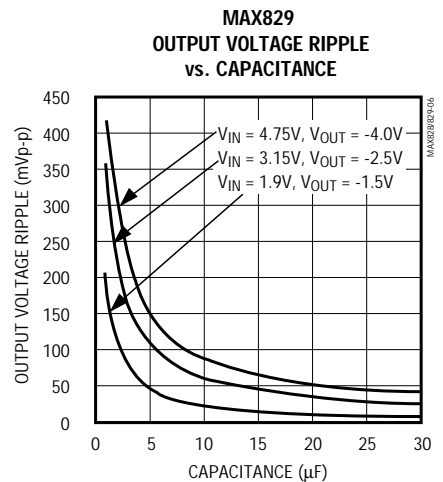
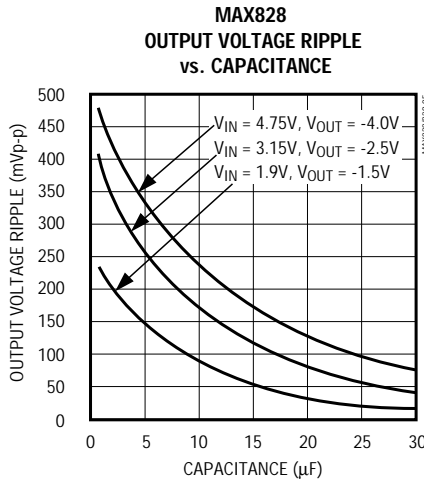
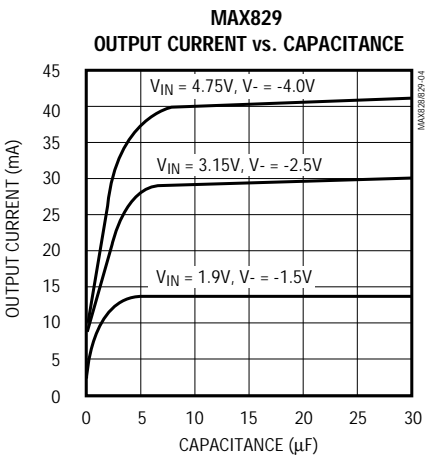
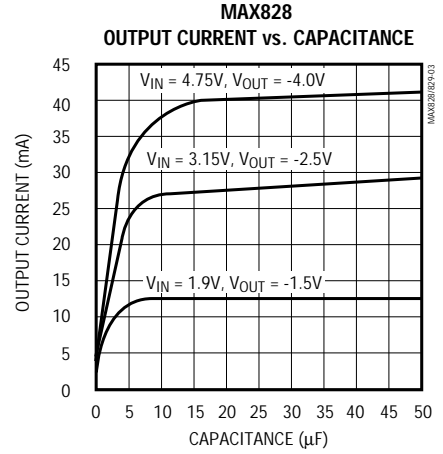
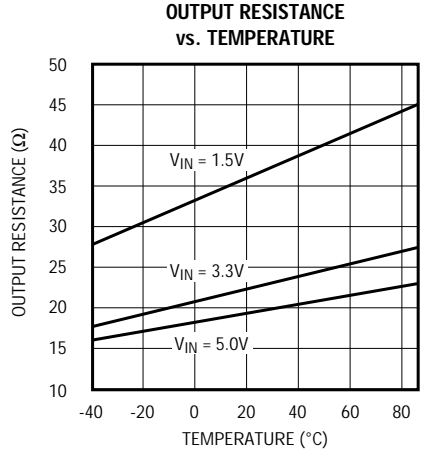
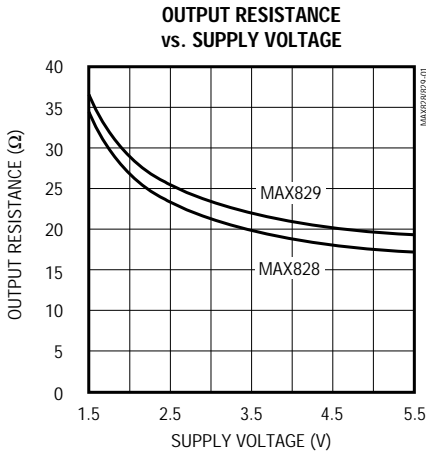

# Switched-Capacitor Voltage Inverters

## Typical Operating Characteristics (continued)

(Circuit of Figure 1,  $V_{IN} = +5V$ ,  $C1 = C2 = C3$ ,  $T_A = +25^\circ C$ , unless otherwise noted.)

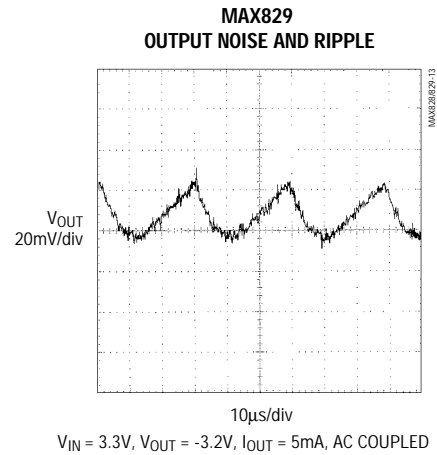
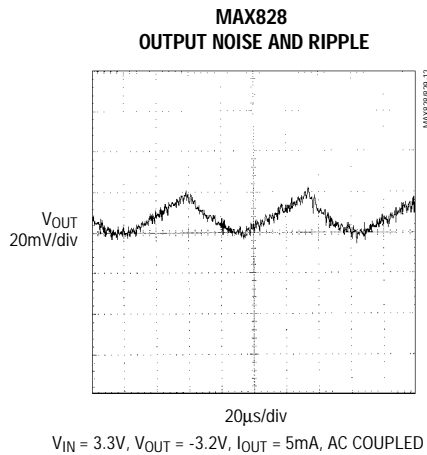
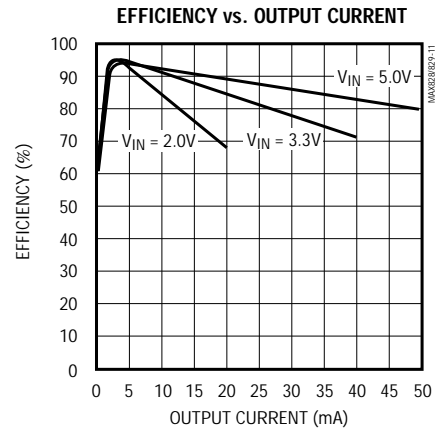
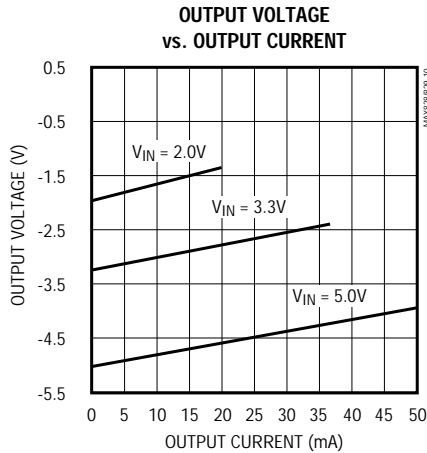

## Pin Description

PIN	NAME	FUNCTION
1	OUT	Inverting Charge-Pump Output
2	IN	Positive Power-Supply Input
3	C1-	Flying Capacitor's Negative Terminal
4	GND	Ground
5	C1+	Flying Capacitor's Positive Terminal

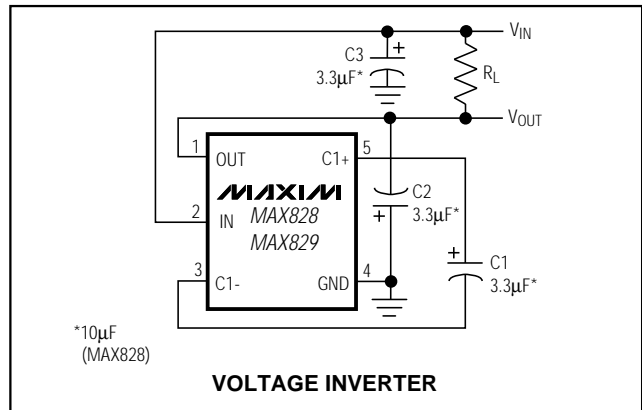

Figure 1. Test Circuit

# Switched-Capacitor Voltage Inverters

## Detailed Description

The MAX828/MAX829 capacitive charge pumps invert the voltage applied to their input. For highest performance, use low equivalent series resistance (ESR) capacitors.

During the first half-cycle, switches S2 and S4 open, switches S1 and S3 close, and capacitor C1 charges to the voltage at IN (Figure 2). During the second half-cycle, S1 and S3 open, S2 and S4 close, and C1 is level shifted downward by  $V_{IN}$  volts. This connects C1 in parallel with the reservoir capacitor C2. If the voltage across C2 is smaller than the voltage across C1, then charge flows from C1 to C2 until the voltage across C2 reaches  $-V_{IN}$ . The actual voltage at the output is more positive than  $-V_{IN}$ , since switches S1–S4 have resistance and the load drains charge from C2.

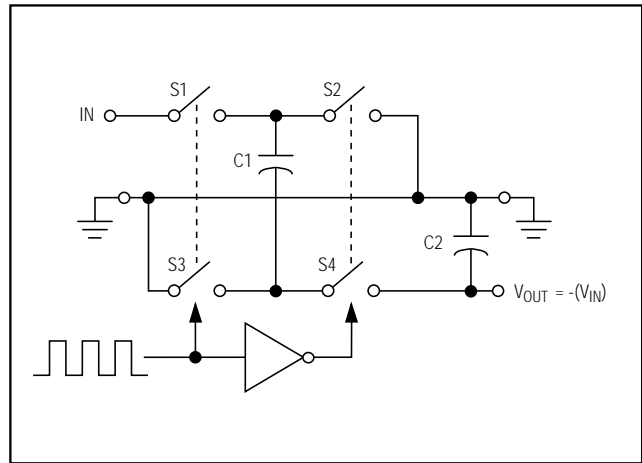

Figure 2. Ideal Voltage Inverter

## Charge-Pump Output

The MAX828/MAX829 are not voltage regulators: the charge pump's output source resistance is approximately  $20\Omega$  at room temperature (with  $V_{IN} = +5V$ ), and  $V_{OUT}$  approaches  $-5V$  when lightly loaded.  $V_{OUT}$  will droop toward GND as load current increases. The droop of the negative supply ( $V_{DROOP-}$ ) equals the current draw from OUT ( $I_{OUT}$ ) times the negative converter's source resistance ( $R_{S-}$ ):

$$V_{DROOP-} = I_{OUT} \times R_{S-}$$

The negative output voltage will be:

$$V_{OUT} = -(V_{IN} - V_{DROOP-})$$

## Efficiency Considerations

The power efficiency of a switched-capacitor voltage converter is affected by three factors: the internal losses in the converter IC, the resistive losses of the pump capacitors, and the conversion losses during charge transfer between the capacitors. The total power loss is:

$$\begin{aligned} \Sigma P_{LOSS} &= P_{INTERNAL\ LOSSES} + P_{SWITCH\ LOSSES} \\ &+ P_{PUMP\ CAPACITOR\ LOSSES} \\ &+ P_{CONVERSION\ LOSSES} \end{aligned}$$

The internal losses are associated with the IC's internal functions, such as driving the switches, oscillator, etc. These losses are affected by operating conditions such as input voltage, temperature, and frequency.

The next two losses are associated with the voltage converter circuit's output resistance. Switch losses occur because of the on-resistance of the MOSFET switches in the IC. Charge-pump capacitor losses occur because of their ESR. The relationship between these losses and the output resistance is as follows:

$$\begin{aligned} P_{PUMP\ CAPACITOR\ LOSSES} + P_{CONVERSION\ LOSSES} \\ &= I_{OUT}^2 \times R_{OUT} \\ R_{OUT} &\cong \frac{1}{(f_{OSC}) \times C1} + 4(2R_{SWITCHES} + ESR_{C1}) + ESR_{C2} \end{aligned}$$

where  $f_{OSC}$  is the oscillator frequency. The first term is the effective resistance from an ideal switched-capacitor circuit. See Figures 3a and 3b.

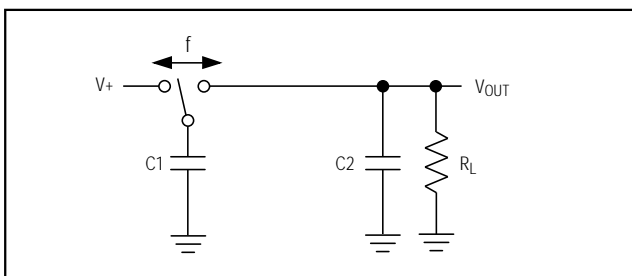

Figure 3a. Switched-Capacitor Model

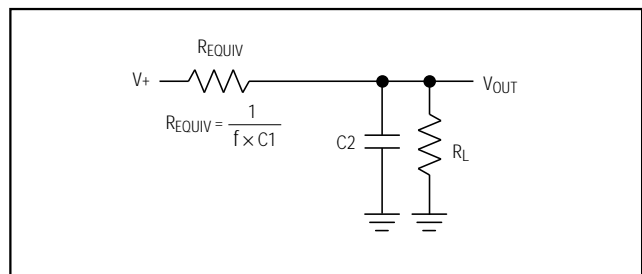

Figure 3b. Equivalent Circuit

# Switched-Capacitor Voltage Inverters

Conversion losses occur during the charge transfer between C1 and C2 when there is a voltage difference between them. The power loss is:

$$P_{\text{CONV.LOSS}} = \left[ \frac{1}{2} C1 \left( V_{\text{IN}}^2 - V_{\text{OUT}}^2 \right) + \frac{1}{2} C2 \left( V_{\text{RIPPLE}}^2 - 2V_{\text{OUT}}V_{\text{RIPPLE}} \right) \right] \times f_{\text{OSC}}$$

## Applications Information

### Capacitor Selection

To maintain the lowest output resistance, use capacitors with low ESR (Table 1). The charge-pump output resistance is a function of C1's and C2's ESR. Therefore, minimizing the charge-pump capacitor's ESR minimizes the total output resistance.

### Flying Capacitor (C1)

Increasing the flying capacitor's size reduces the output resistance. Small C1 values increase the output resistance. Above a certain point, increasing C1's capacitance has a negligible effect, because the output resistance becomes dominated by the internal switch resistance and capacitor ESR.

### Output Capacitor (C2)

Increasing the output capacitor's size reduces the output ripple voltage. Decreasing its ESR reduces both output resistance and ripple. Smaller capacitance values can be used with light loads if higher output ripple can be tolerated. Use the following equation to calculate the peak-to-peak ripple:

$$V_{\text{RIPPLE}} = \frac{I_{\text{OUT}}}{f_{\text{OSC}} \times C2} + 2 \times I_{\text{OUT}} \times \text{ESR}_{C2}$$

### Input Bypass Capacitor

Bypass the incoming supply to reduce its AC impedance and the impact of the MAX828/MAX829's switching noise. The recommended bypassing depends on the circuit configuration and on where the load is connected.

When the inverter is loaded from OUT to GND, current from the supply switches between  $2 \times I_{\text{OUT}}$  and zero. Therefore, use a large bypass capacitor (e.g., equal to the value of C1) if the supply has a high AC impedance.

When the inverter is loaded from IN to OUT, the circuit draws  $2 \times I_{\text{OUT}}$  constantly, except for short switching spikes. A 0.1μF bypass capacitor is sufficient.

### Voltage Inverter

The most common application for these devices is a charge-pump voltage inverter (Figure 1). This application requires only two external components—capacitors C1 and C2—plus a bypass capacitor, if necessary. Refer to the *Capacitor Selection* section for suggested capacitor types and values.

### Cascading Devices

Two devices can be cascaded to produce an even larger negative voltage (Figure 4). The unloaded output voltage is normally  $-2 \times V_{\text{IN}}$ , but this is reduced slightly by the output resistance of the first device multiplied by the quiescent current of the second. When cascading more than two devices, the output resistance rises dramatically. For applications requiring larger negative voltages, see the MAX864 and MAX865 data sheets.

### Paralleling Devices

Paralleling multiple MAX828s or MAX829s reduces the output resistance. Each device requires its own pump capacitor (C1), but the reservoir capacitor (C2) serves all devices (Figure 5). Increase C2's value by a factor of n, where n is the number of parallel devices. The equation for calculating output resistance is also shown in Figure 5.

**Table 1. Low-ESR Capacitor Manufacturers**

MANUFACTURER		PHONE	FAX	DEVICE TYPE
AVX		(803) 946-0690 (800) 282-4975	(803) 626-3123	Surface-mount, TPS series
Matsuo		(714) 969-2491	(714) 960-6492	Surface-mount, 267 series
Sanyo	USA	(619) 661-6835	(619) 661-1055	Through-hole, OS-CON series
	Japan	81-7-2070-6306	81-7-2070-1174	
Sprague		(603) 224-1961	(603) 224-1430	Surface-mount, 595D series

# Switched-Capacitor Voltage Inverters

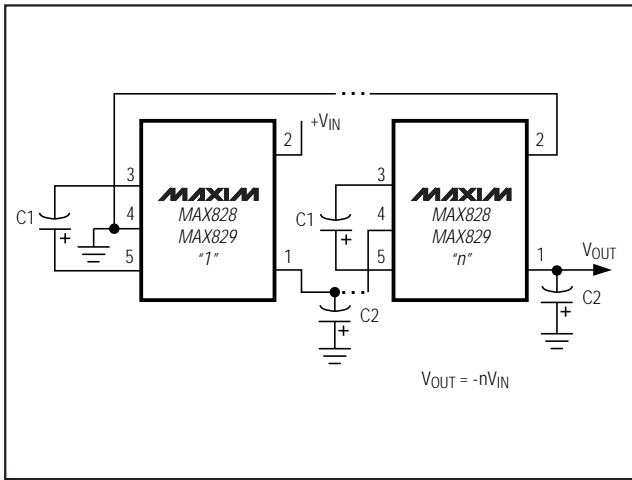

Figure 4. Cascading MAX828s or MAX829s to Increase Output Voltage

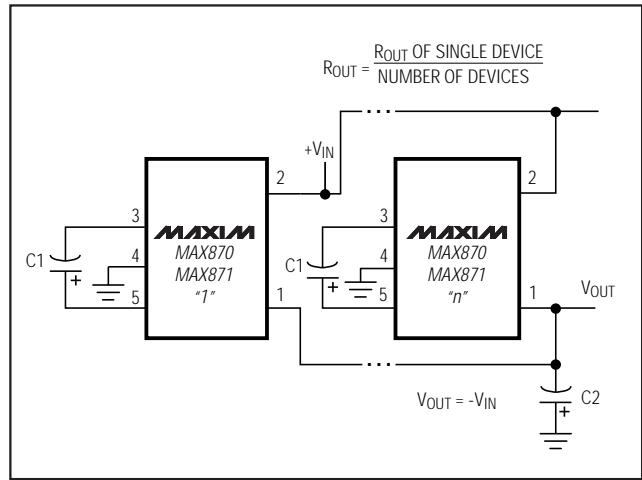

Figure 5. Paralleling MAX828s or MAX829s to Reduce Output Resistance

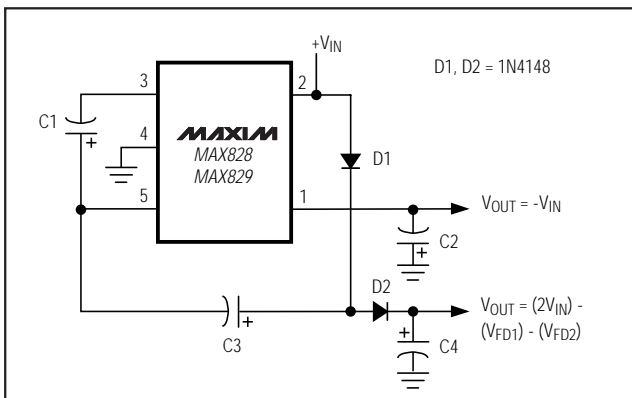

Figure 6. Combined Doubler and Inverter

## Combined Doubler/Inverter

In the circuit of Figure 6, capacitors C1 and C2 form the inverter, while C3 and C4 form the doubler. C1 and C3 are the pump capacitors; C2 and C4 are the reservoir capacitors. Because both the inverter and doubler use part of the charge-pump circuit, loading either output causes both outputs to decline toward GND. Make sure the sum of the currents drawn from the two outputs does not exceed 40mA.

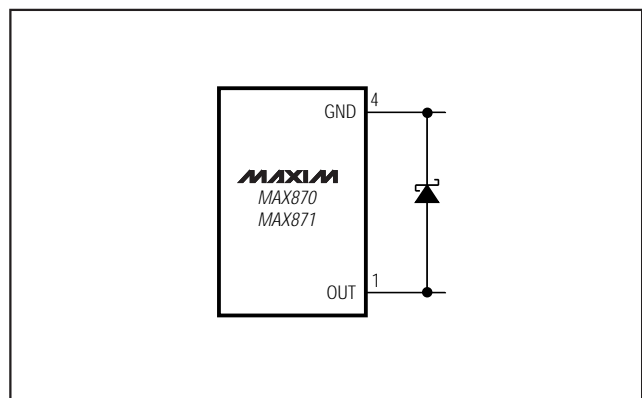

Figure 7. High V- Load Current

## Heavy Output Current Loads

When under heavy loads, where higher supply is sourcing current into OUT, the OUT supply must not be pulled above ground. Applications that sink heavy current into OUT require a Schottky diode (1N5817) between GND and OUT, with the anode connected to OUT (Figure 7).

## Layout and Grounding

Good layout is important, primarily for good noise performance. To ensure good layout, mount all components as close together as possible, keep traces short to minimize parasitic inductance and capacitance, and use a ground plane.

# Switched-Capacitor Voltage Inverters

## Shutting Down the MAX828/MAX829

If shutdown is necessary, use the circuit in Figure 8. The output resistance of the MAX828/MAX829 will typically be  $20\Omega$  plus two times the output resistance of the buffer driving IN. The  $0.1\mu\text{F}$  capacitor at the IN pin absorbs the transient input currents of the MAX828/MAX829.

The output resistance of the buffer driving the IN pin can be reduced by connecting multiple buffers in parallel. The polarity of the SHUTDOWN signal can also be changed by using a noninverting buffer to drive IN.

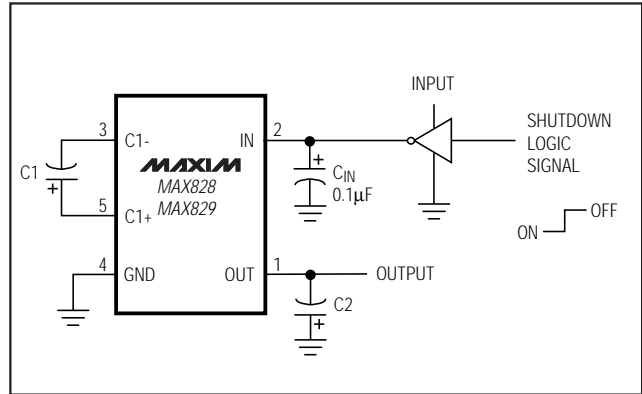
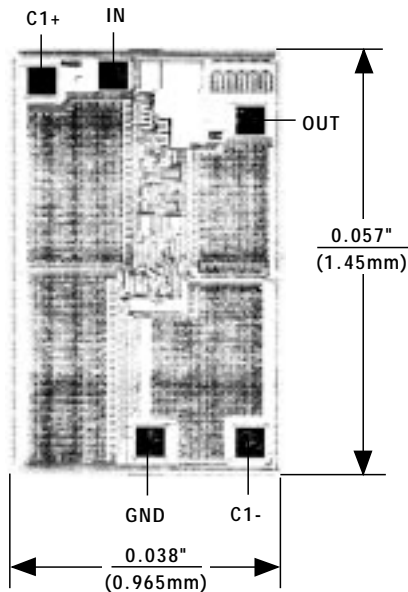

Figure 8. Shutdown Control

## Chip Topography



TRANSISTOR COUNT: 58

SUBSTRATE CONNECTED TO IN

Maxim cannot assume responsibility for use of any circuitry other than circuitry entirely embodied in a Maxim product. No circuit patent licenses are implied. Maxim reserves the right to change the circuitry and specifications without notice at any time.

8 Maxim Integrated Products, 120 San Gabriel Drive, Sunnyvale, CA 94086 408-737-7600