

**MC14467-1**

**CMOS MSI**  
 (LOW-POWER COMPLEMENTARY MOS)

**IONIZATION SMOKE DETECTOR**

**IONIZATION SMOKE DETECTOR**

The MC14467-1, when used with an ionization chamber and a small number of external components, will detect smoke. When smoke is sensed, an alarm is sounded via an external piezoelectric transducer and internal drivers. This circuit is designed to comply with the UL217 and UL268 specifications.

- Ionization Type with On-Chip FET Input Comparator
- Piezoelectric Horn Driver
- Guard Outputs on Both Sides of Detect Input
- Input-Production Diodes on the Detect Input
- Low-Battery Trip Point, Internally Set, Can Be Altered Via External Resistor
- Detect Threshold, Internally Set, Can Be Altered Via External Resistor
- Pulse Testing for Low Battery Uses LED for Battery Loading
- Comparator Outputs for Detect and Low Battery
- Internal Reverse Battery Protection

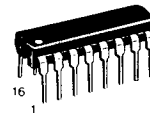

P SUFFIX  
 PLASTIC DIP  
 CASE 648

**ORDERING INFORMATION**

MC14467P1 Plastic DIP

**BLOCK DIAGRAM**

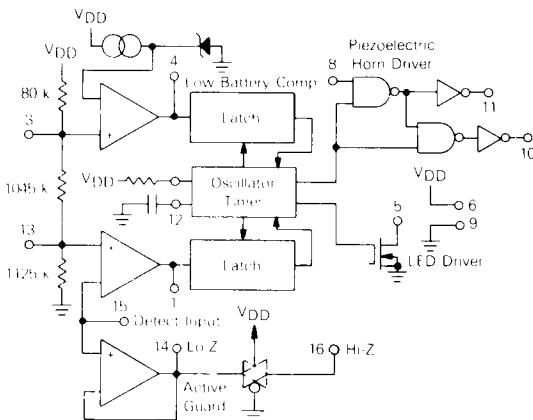

**PIN ASSIGNMENT**

Detect Comp. Out	1	16	Guard Hi-Z
N/C	2	15	Detect Input
Low V Set	3	14	Guard Lo-Z
Low V Comp. Out	4	13	Sensitivity Set
LED	5	12	Osc Capacitor
VDD	6	11	Silver
Timing Resistor	7	10	Brass
Feedback	8	9	VSS

**MAXIMUM RATINGS\*** (Voltages referenced to  $V_{SS}$ )

Rating	Symbol	Value	Unit
DC Supply Voltage	$V_{DD}$	-0.5 to +15	V
Input Voltage, All Inputs Except Pin 8	$V_{in}$	-0.25 to $V_{DD} + 0.25$	V
DC Current Drain per Input Pin, Except Pin 15 = 1 mA	$I$	10	mA
DC Current Drain per Output Pin	$I$	30	mA
Operating Temperature Range	$T_A$	-10 to +60	°C
Storage Temperature Range	$T_{stg}$	-55 to +125	°C
Reverse Battery Time	$t_{RB}$	5.0	s

\*Maximum Ratings are those values beyond which damage to the device may occur.

**RECOMMENDED OPERATING CONDITIONS** (Voltages referenced to  $V_{SS}$ )

Parameter	Symbol	Value	Unit
Supply Voltage	$V_{DD}$	9.0	V
Timing Capacitor	—	0.1	$\mu$ F
Timing Resistor	—	8.2	M $\Omega$
Battery Load (Resistor or LED)	—	10	mA

**ELECTRICAL CHARACTERISTICS** (Voltages referenced to  $V_{SS}$ ,  $T_A = 25^\circ\text{C}$ )

Characteristic	Symbol	$V_{DD}$ $V_{dc}$	Min	Typ#	Max	Unit
Operating Voltage	$V_{DD}$	—	6.0	—	12	V
Output Voltage	$V_{OH}$	7.2	6.3	—	—	V
Piezoelectric Horn Drivers ( $I_{OH} = -16$ mA)		9.0	8.5	8.8	—	
Comparators ( $I_{OH} = -30$ $\mu$ A)						
Piezoelectric Horn Drivers ( $I_{OL} = +16$ mA)	$V_{OL}$	7.2	—	—	0.9	V
Comparators ( $I_{OL} = +30$ $\mu$ A)		9.0	—	0.1	0.5	
Output Voltage — LED Driver, $I_{OL} = 10$ mA	$V_{OL}$	7.2	—	—	3.0	V
Output Impedance, Active Guard	Pin 14 Lo-Z	9.0	—	—	10	k $\Omega$
	Pin 16 Hi-Z	9.0	—	—	1000	
Operating Current ( $R_{bias} = 8.2$ M $\Omega$ )	$I_{DD}$	9.0	—	5.0	9.0	$\mu$ A
		12.0	—	—	12.0	
Input Current — Detect (40% R.H.)	$I_{in}$	9.0	—	—	$\pm 1.0$	pA
Internal Set Voltage						
Low Battery	$V_{low}$	9.0	7.2	—	7.8	V
Sensitivity	$V_{set}$	—	47	50	53	% $V_{DD}$
Hysteresis	$V_{hys}$	9.0	75	100	150	mV
Offset Voltage (measured at $V_{in} = V_{DD}/2$ )	$V_{OS}$	9.0	—	—	$\pm 100$	mV
Active Guard		9.0	—	—	$\pm 50$	
Detect Comparator		9.0	—	—	—	
Input Voltage Range, Pin 8	$V_{in}$	—	-10	—	$V_{DD} + 10$	V
Input Capacitance	$C_{in}$	—	—	5.0	—	pF
Common Mode Voltage Range, Pin 15	$V_{cm}$	—	0.6	—	$V_{DD} - 2$	V

#Data labelled "Typ" is not to be used for design purposes but is intended as an indication of the IC's potential performance.

This device contains circuitry to protect the inputs against damage due to high static voltages or electric fields; however, it is advised that normal precautions be taken to avoid application of any voltage higher than maximum rated voltages to this high impedance circuit. For proper operation it is recommended that except for pin 8,  $V_{in}$  and  $V_{out}$  be constrained to the range  $V_{SS} \leq (V_{in} \text{ or } V_{out}) \leq V_{DD}$ . For pin 8, refer to the Electrical Characteristics.

TIMING PARAMETERS (C = 0.1 μF, R<sub>bias</sub> = 8.2 MΩ, V<sub>DD</sub> = 9.0 V, T<sub>A</sub> = 25°C, See Figure 5)

Characteristics		Symbol	Min	Typ#	Max	Units
Oscillator Period	No Smoke	t <sub>Cl</sub>	1.34	1.67	2.0	s
	Smoke		32	40	48	ms
Oscillator Rise Time		t <sub>r</sub>	8	10	12	ms
Horn Output (During Smoke)	On Time	PW <sub>on</sub>	120	160	208	ms
	Off Time	PW <sub>off</sub>	60	80	104	ms
LED Output	Between Pulses	t <sub>LED</sub>	32	40	48	s
	On Time	PW <sub>on</sub>	8	10	12	ms
Horn Output (During Low Battery)	On Time	t <sub>on</sub>	8	10	12	ms
	Between Pulses	t <sub>off</sub>	32	40	48	s

#Data labelled "Typ" is not to be used for design purposes but is intended as an indication of the IC's potential performance.

FIGURE 2 – TYPICAL LED OUTPUT I-V CHARACTERISTIC

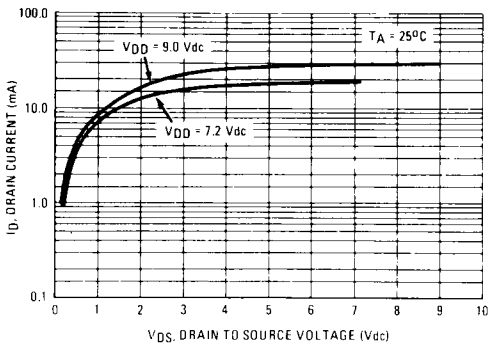

FIGURE 3 – TYPICAL COMPARATOR OUTPUT I-V CHARACTERISTIC

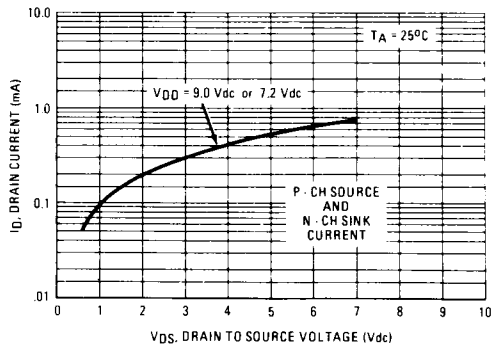
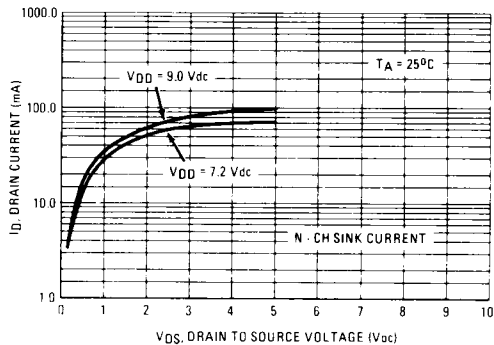
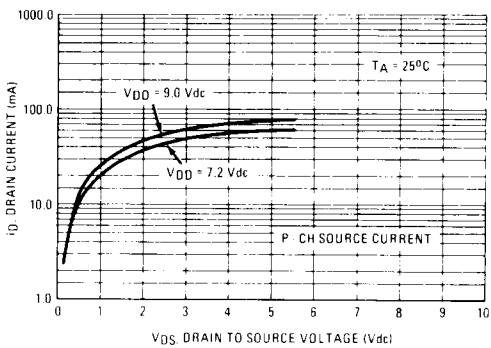

FIGURE 4 – TYPICAL P HORN DRIVER OUTPUT I-V CHARACTERISTIC



DEVICE OPERATION

TIMING

The internal oscillator of the MC14467-1 operates with a period of 1.67 seconds during no-smoke conditions. Each 1.67 seconds, internal power is applied to the entire IC and a check is made for smoke, except during LED pulse, Low Battery Alarm Chirp, or Horn Modulation (in smoke). Every 24 clock cycles a check is made for low battery by comparing  $V_{DD}$  to an internal zener voltage. Since very small currents are used in the oscillator, the oscillator capacitor should be of a low leakage type.

DETECT CIRCUITRY

If smoke is detected, the oscillator period becomes 40 ms and the piezoelectric horn oscillator circuit is enabled. The horn output is modulated 160 ms on, 80 ms off. During the off time, smoke is again checked and will inhibit further horn output if no smoke is sensed. During smoke conditions the low battery alarm is inhibited, but the LED pulses at a 1.0 Hz rate.

An active guard is provided on both pins adjacent to the detect input. The voltage at these pins will be within 100 mV of the input signal. This will keep surface leakage currents to a minimum and provide a method of measuring the input voltage without loading the ionization chamber. The active guard op amp is not power strobed and thus gives constant protection from surface leakage currents. Pin 15 (the Detect input) has internal diode protection against static damage

SENSITIVITY/LOW BATTERY THRESHOLDS

Both the sensitivity threshold and the low battery voltage

levels are set internally by a common voltage divider connected between  $V_{DD}$  and  $V_{SS}$ . These voltages can be altered by external resistors connected from pins 3 or 13 to either  $V_{DD}$  or  $V_{SS}$ . There will be a slight interaction here due to the common voltage divider network. The sensitivity threshold can also be set by adjusting the smoke chamber ionization source.

TEST MODE

Since the internal op amps and comparators are power strobed, adjustments for sensitivity or low battery level could be difficult and/or time-consuming. By forcing Pin 12 to  $V_{SS}$ , the power strobing is bypassed and the outputs, Pins 1 and 4, constantly show smoke/no smoke and good battery/low battery, respectively. Pin 1 =  $V_{DD}$  for smoke and Pin 4 =  $V_{DD}$  for low battery. In this mode and during the 10 ms power strobe, chip current rises to approximately 50  $\mu A$ .

LED PULSE

The 9-volt battery level is checked every 40 seconds during the LED pulse. The battery is loaded via a 10 mA pulse for 10 ms. If the LED is not used, it should be replaced with an equivalent resistor such that the battery loading remains at 10 mA.

HYSTERESIS

When smoke is detected, the resistor/divider network that sets sensitivity is altered to increase sensitivity. This yields approximately 100 mV of hysteresis and reduces false triggering.

7

FIGURE 1 — TYPICAL APPLICATION AS IONIZATION SMOKE DETECTOR

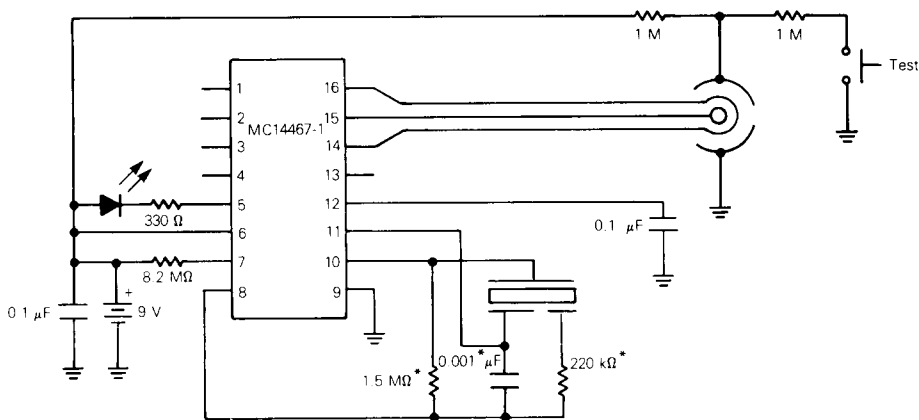

\*NOTE: Component values may change depending on type of piezoelectric horn used

FIGURE 5 — TIMING DIAGRAM

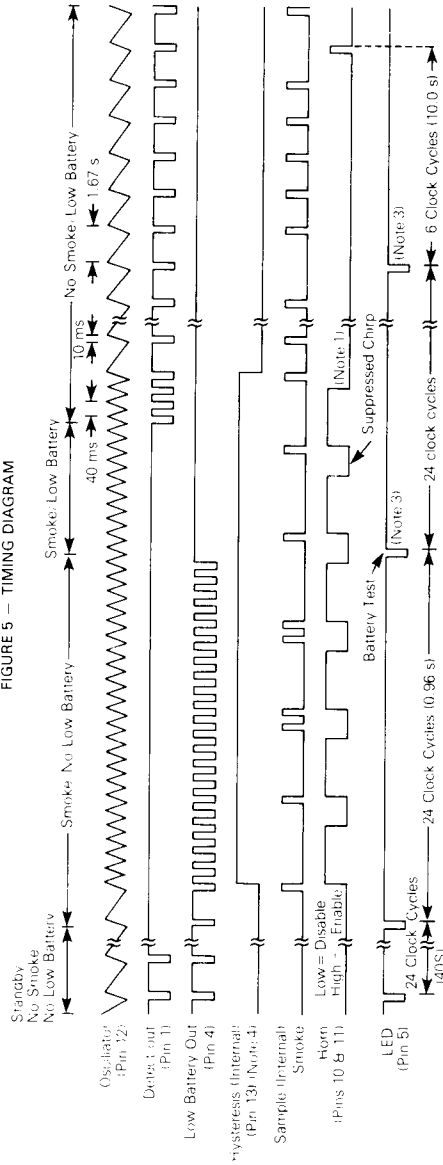

- NOTES
1. Horn modulation is self-completing. When going from smoke to no smoke, the alarm condition will terminate only when horn is off.
  2. Comparators are strobed on once per clock cycle (1.67 s for no smoke, 40 ms for smoke).
  3. Low battery comparator information is latched only during LED pulse.
  4. ~ 100 mV p-p swing.