

FEATURES

- Turn On Current (IFT), 5.0 mA Typical
- Gate Trigger Current (IGT), 20 μ A
- Surge Anode Current, 1.0 Amp
- Blocking Voltage, 400 V
- Gate Trigger Voltage (VGT), 0.6 Volt
- Isolation Voltage, 5300 VAC_{RMS}
- Solid State Reliability
- Standard DIP Package
- Underwriters Lab File #E52744

DESCRIPTION

The IL400 is an optically coupled SCR with a Gallium Arsenide infrared emitter and a silicon photo SCR sensor. Switching can be achieved while maintaining a high degree of isolation between triggering and load circuits. The IL400 can be used in SCR triac and solid state relay applications where high blocking voltages and low input current sensitivity are required.

Maximum Ratings

Emitter

Peak Reverse Voltage 6.0 V
 Peak Forward Current
 (100 μ s, 1% Duty Cycle) 1.0 A
 Continuous Forward Current 60 mA
 Power Dissipation at 25°C 100 mW
 Derate Linearly from 25°C 1.3 mW/°C

Detector

Reverse Gate Voltage 6.0 V
 Anode Voltage (DC or AC Peak) 400 V
 Anode Current 100 mA
 Surge Anode Current (10 ms duration) 1.0 A
 Surge Gate Current (5 ms duration) 200 mA
 Power Dissipation, 25°C ambient 200 mW
 Derate Linearly from 25°C 2.11 mW/°C

Package

Isolation Voltage 5300 VAC_{RMS}
 Isolation Resistance
 $V_{IO}=500$ V, $T_A=25^\circ\text{C}$ min. 10^{12} Ω
 $V_{IO}=500$ V, $T_A=100^\circ\text{C}$ min. 10^{11} Ω
 Total Package Dissipation 250 mW
 Derate Linearly from 25°C 2.63 mW/°C
 Operating Temperature -55°C to +100°C
 Storage Temperature -55°C to +150°C

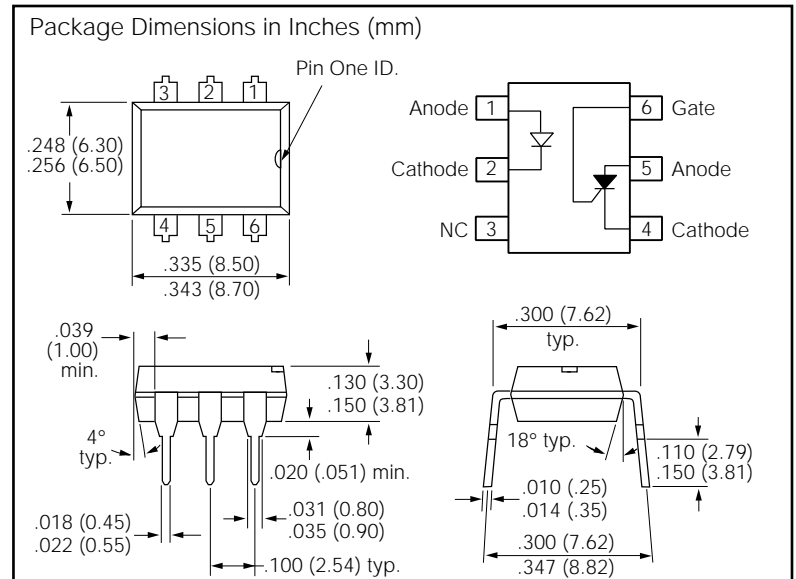

Characteristics ($T_A=25^\circ\text{C}$)

	Symbol	Min.	Typ.	Max.	Unit	Condition
Emitter						
Forward Voltage	V_F		1.2	1.5	V	$I_F=20$ mA
Reverse Voltage	V_R	5.0			V	$I_R=10$ μ A
Reverse Current	I_R			10	μ A	$V_R=5$ V
Detector						
Forward Blocking Voltage	V_{DRM}	400			V	$R_{GK}=10$ K Ω $T_A=100^\circ\text{C}$ $I_d=150$ μ A
Reverse Blocking Voltage	V_{DRRM}	400			V	$R_{GK}=10$ K Ω $T_A=100^\circ\text{C}$ $I_d=150$ μ A
On-state Voltage	V_t			1.2	V	$I_T=100$ mA
Holding Current	I_H			500	μ A	$R_{GK}=27$ K Ω $V_{FX}=50$ V
Gate Trigger Voltage	V_{GT}		0.6	1.0	V	$V_{FX}=100$ V $R_{GK}=27$ K Ω $R_L=10$ K Ω
Forward Leakage Current	I_D		0.2	2.0	μ A	$R_{GK}=27$ K Ω $V_{RX}=400$ V $I_F=0$, $T_A=25^\circ\text{C}$
Reverse Leakage Current	I_R		0.2	2.0	μ A	$R_{GK}=27$ K Ω $V_{RX}=400$ V $I_F=0$, $T_A=25^\circ\text{C}$
Gate Trigger Current	I_{GT}		20	50	μ A	$V_{FX}=100$ V $R_{GK}=27$ K Ω , $R_L=10$ K Ω
Package						
Turn-On Current	I_{FT}	0.5	5.0	10.0	mA	$V_{FX}=100$ V $R_{GK}=27$ K Ω
Isolation Capacitance				2	pF	$f=1$ MHz