

W523AXXX DATA SHEET



HIGH FIDELITY *PowerSpeech™*

GENERAL DESCRIPTION

The W523Axxx family are programmable speech synthesis ICs that utilize Winbond's new high fidelity voice synthesis algorithm to generate all types of voice effects with high sound quality.

The W523Axxx's LOAD, JUMP, MOVE and INC commands and ten programmable registers provide powerful user-programmable functions that make this chip suitable for an extremely wide range of speech IC applications.

The W523Axxx family includes 14 kinds of part numbers with same function except for the voice duration shown below:

| | | | | | | | |
|-----------------|-----------------|-----------------|-----------------|-----------------|-----------------|-----------------|-----------------|
| PART NO. | W523A008 | W523A010 | W523A012 | W523A015 | W523A020 | W523A025 | W523A030 |
| Duration | 8 sec. | 10 sec. | 12 sec. | 15 sec. | 20 sec. | 25 sec. | 30 sec. |
| PART NO. | W523A040 | W523A050 | W523A060 | W523A070 | W523A080 | W523A100 | W523A120 |
| Duration | 40 sec. | 50 sec. | 60 sec. | 70 sec. | 80 sec. | 100 sec. | 120 sec. |

Note: The voice duration is estimated by various sampling rate.

FEATURES

- Operating voltage range: 2.4 – 5.5 volts
- New high fidelity synthesis algorithm
- Either PWM mode or D/A converter mode can be selected for AUD output
- Provides 4 direct trigger inputs that can easily be extended to 24 matrix trigger inputs
- Two trigger input debounce times (50 mS or 400 uS) can be set
- Provides up to 2 LEDs and 5 STOP outputs
- Flexible functions programmable through the following:
 - LD (Load), JP (Jump), MV (Move) and INC (Increase) commands
 - Four general purpose registers: R0, R1, R2 and R3
 - Six special purpose registers: EN0, EN1 (excludes W523A008 and W523A010), MODE0, MODE1, STOP and PAGE
 - Conditional instructions: @LAST, @TGn_HIGH or LOW, where, n = 1,2,5 or 6 for W523A012 ~ W523A120; n=1,2,3 or 4 for W523A008 and W523A010
 - Speech equations
 - END instruction
- Supports CPU interface operation
- Symbolic compiler supported
- Instruction cycle $\leq 400 \mu\text{S}$ typically

- Section control for
 - Variable frequency: 4.8/6/8/12 KHz
 - LED: ON/OFF
- Up to 256 voice groups can be used in single page mode; or extended to 2,048 voice groups in multi page mode, such as 8-page, 16-page and 32-page.

BLOCK DIAGRAM

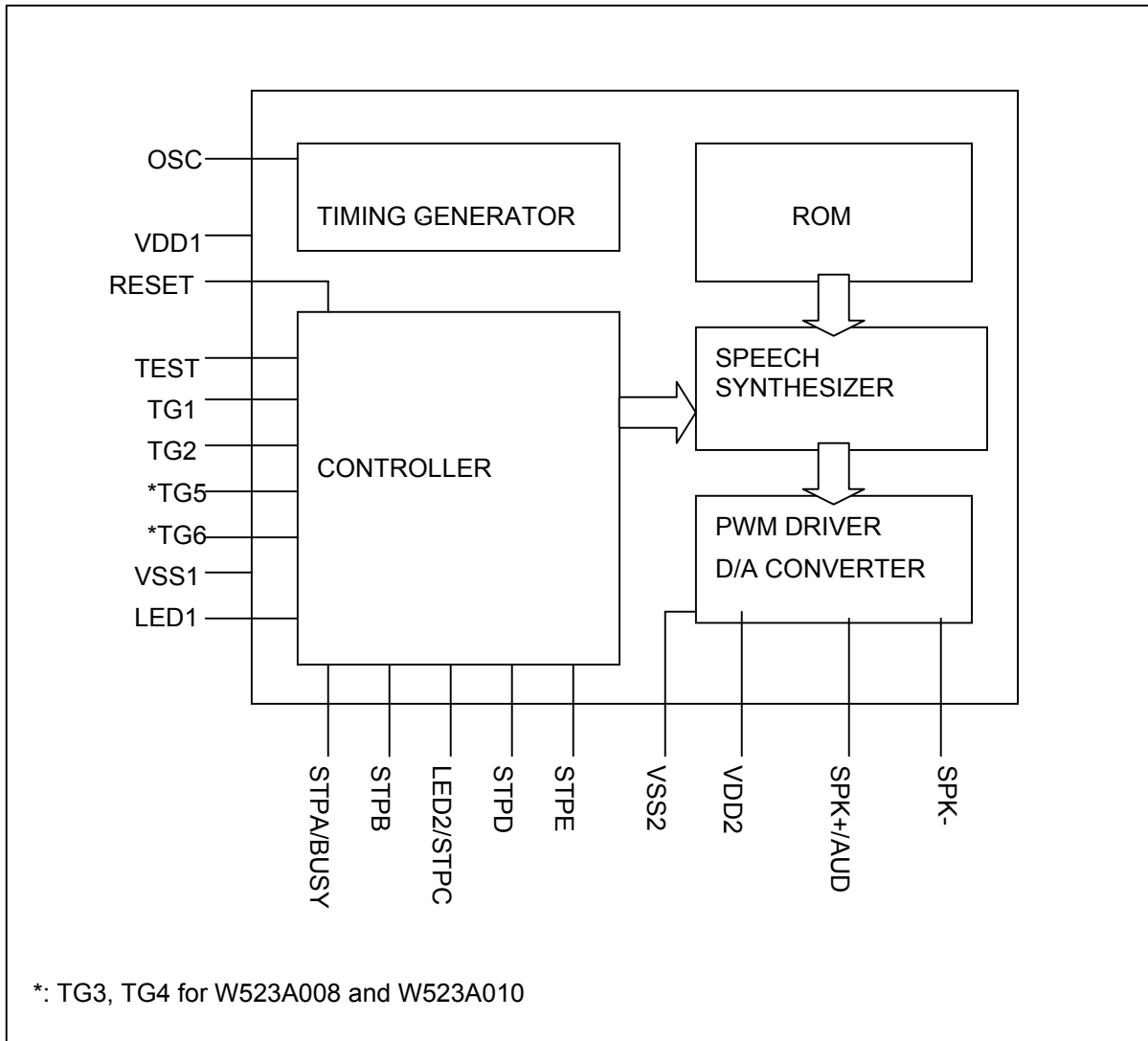



PIN DESCRIPTION

| NAME | I/O | DESCRIPTION |
|---------------------------|-----|--|
| OSC | I | Ring oscillator input |
| VDD1 | - | Positive power supply |
| TEST | I | Test pin. Internally pulled low |
| $\overline{\text{RESET}}$ | I | Active low to reset all devices as POR function. Internally pulled high. |
| TG1 | I | Direct trigger input 1. Internally pulled high |
| TG2 | I | Direct trigger input 2. Internally pulled high |
| *TG5 | I | Direct trigger input 5. Internally pulled high |
| *TG6 | I | Direct trigger input 6. Internally pulled high |
| VSS1 | - | Negative power supply |
| LED1 | O | LED1 output |
| STPA/BUSY | O | Stop signal A or Busy signal |
| STPB | O | Stop signal B |
| LED2/STPC | O | LED2 output or Stop signal C |
| STPD | O | Stop signal D |
| STPE | O | Stop signal E |
| SPK- | O | PWM output |
| AUD/SPK+ | O | Current type output or PWM output for speaker |
| VSS2 | - | Negative power supply |
| VDD2 | - | Positive power supply |

*: TG3, TG4 for W523A008 and W523A010

FUNCTIONAL DESCRIPTION

I/O pins:

The W523Axxx family provides up to 4 trigger pins, which can be extended to 24 matrix trigger inputs, up to 5 STOP output pins and up to 2 LED output pins. All of these I/O pins' status can be easily defined by *PowerSpeech™* program.

Powerful programmable features:

The W523Axxx family provides JUMP (JP), LOAD (LD), MOVE (MV), INC, and END commands and 10 programmable registers, such as R0 ~ R3, EN0, EN1, MODE0, MODE1, STOP and PAGE, can be easily used to program the desired playing mode, stop output signal form, LED flash type, and trigger pin interrupt modes. The chip's programmable features can also be used to develop new, customized functions for a wide variety of innovative applications.

Programmable Power-on Initialization:

Whenever the W523Axxx is powered on or pressed the $\overline{\text{RESET}}$ pin, the program contained in the



32nd voice group will be executed after the power-on delay (about 160 mS), so the user can write a program into this group to set the power-on initial state. If user does not wish to execute a program at power-on, an “END” instruction should be entered in the group 32.

The interruption priority is shown as below while other trigger pins as well as JUMP (JP) command are executing simultaneously during POI executing period:

POI > TG1F > TG1R > TG2F > TG2R > *TG5F > *TG5R > *TG6F > *TG6R > "JP" instruction.

*: TG3, TG4 for W523A008, W523A010

Register Definition and Control

The register file in the W523Axxx family is composed of 10 registers, including 4 general-purpose registers and 6 special purpose registers. They are defined to facilitate the operations for various purposes. The default setting values of the registers are given in the following table.

| REGISTER | NAME | DEFAULT SETTING |
|------------------|---------------------|-----------------|
| General Register | R0-R3 | 00100000B |
| Special Register | EN0 (W523A008~A010) | 11111111B |
| | EN0 (W523A012~A120) | XX11XX11B |
| | EN1 (W523A012~A120) | XX11XX11B |
| | MODE0, MODE1 | 11111111B |
| | STOP | XXX11111B |
| | PAGE | 00000000B |

1. MODE0 Register

| BIT | DESCRIPTION | DEFINITION |
|---------|-------------------------|----------------|
| 7 | LED mode | 1: Flash |
| | | 0: DC |
| 6 | LED2/STPC pin selection | 1: LED2 output |
| | | 0: STPC output |
| 4 | Debounce time | 1: Long |
| | | 0: Short |
| 2 | STPA/BUSY pin selection | 1: STPA output |
| | | 0: BUSY output |
| 5,3,1,0 | X | Don't care |

The MODE0.7 bit defines the output type of LED1 and LED2 pins as Flash output (3 Hz) or DC output. The MODE0.6 bit defines the configuration of LED2/STPC pin's status as LED2 output or STPC output. The MODE0.4 bit defines the trigger pin's debounce time as long debounce (50 mS) or short debounce (400 uS). The MODE0.2 bit defines the behavior of the STPA/BUSY pin as STPA output in



normal mode or BUSY signal output in CPU mode. The bits 5, 3, 1 and 0 are don't care bits.

2. MODE1 Register

| BIT | DESCRIPTION | DEFINITION |
|------------|----------------------|--------------------|
| 7, 6, 1, 0 | X | Don't care |
| 5 | LED Flash type | 1: Alternate |
| | | 0: Synchronous |
| 4 | LED1 section control | 1: YES |
| | | 0: NO |
| 3 | LED2 control | 1: SECTION control |
| | | 0: STPC control |
| 2 | LED1 volume control | 1: OFF |
| | | 0: ON |

MODE1.5 is for LED flash type control. MODE1.4 is for LED1 section control ON/OFF. MODE1.3 is for LED2 Section/STPC control. MODE1.2 is for LED1 volume control.

3. PAGE Register

| BIT | 7 | 6 | 5 | 4 | 3 | 2 | 1 | 0 |
|------|---|---|---|-----|-----|-----|-----|-----|
| PAGE | - | - | - | PG4 | PG3 | PG2 | PG1 | PG0 |

The bits 0 ~ 4 in PAGE register are used for page selection. Once the page mode being defined (referring to the below section of "Option Control Function"), the working page is selected by the bits 0 ~ 4 in the PAGE register. Hence, the user can execute "LD PAGE, value" instruction to change the working page of the voice entry group. Not all of the bits 0 ~ 4 of PAGE register are used in different page mode. They are listed as below table:

| PAGE MODE | PG4 | PG3 | PG2 | PG1 | PG0 |
|-----------|-----|-----|-----|-----|-----|
| 1-page | x | x | x | x | x |
| 8-page | x | x | √ | √ | √ |
| 16-page | x | √ | √ | √ | √ |
| 32-page | √ | √ | √ | √ | √ |

Where "x" means don't care and "√" means must be set properly.

4. EN Register (W523A012 ~ W523A120)

| BIT | 7 | 6 | 5 | 4 | 3 | 2 | 1 | 0 |
|-----|---|---|------|------|---|---|------|------|
| EN0 | X | X | TG2R | TG1R | X | X | TG2F | TG1F |
| EN1 | X | X | TG6R | TG5R | X | X | TG6F | TG5F |



EN Register (W523A008, W523A010)

| BIT | 7 | 6 | 5 | 4 | 3 | 2 | 1 | 0 |
|-----|------|------|------|------|------|------|------|------|
| EN0 | TG4R | TG3R | TG2R | TG1R | TG4F | TG3F | TG2F | TG1F |

EN0 or EN1 is an 8-bit register that stores the rising/falling edge enable or disable status information for all trigger pins, which determines whether each trigger pin is retriggerable, non-retriggerable, overwrite, or non-overwrite. The 8-bit structure of this register and the rising or falling edge of the triggers corresponding to each bit are shown above. "X" indicates a "don't care" bit.

The TG1, 2, 5, 6 represents triggers 1, 2, 5 and 6 respectively; the "R" represents the rising edge; and "F" represents the falling edge. When any one of the eight bits is set to "1", the rising or falling edge of the corresponding trigger pin can be enabled, interrupting the current state.

5. STOP Register

| BIT | 7 | 6 | 5 | 4 | 3 | 2 | 1 | 0 |
|------|---|---|---|-----|-----|-----|-----|-----|
| STOP | X | X | X | STE | STD | STC | STB | STA |

The STOP register stores stop output status information to determine the voltage level of each stop output pin. The 8-bit structure of this register and the stop output pin corresponding to each bit are shown as above table. The "X" indicates a "don't care" bit. When a particular STOP bit is set to "1", the corresponding stop signal will be an active high output.

6. R0-R3 Registers

These four registers are 8-bit register that stores the entry values of from 0 to 255 voice groups. R0 is a special register that can be incremented by "INC" instruction.

Option Control Function

There are four types of option control in W523Axxx. They can be determined by a declaration in the user's program file, but cannot be controlled by register.

| FUNCTION | MASK OPTION DECLARATION | DEFINITION |
|-------------------------|-------------------------|---|
| Page mode configuration | DEFPAGE 1 | 256 interrupt vector/label for 1 page, 1 page in total (1-page mode) |
| | DEFPAGE 8 | 256 interrupt vector/label for 1 page, 8 pages in total (8-page mode) |
| | DEFPAGE 16 | 128 interrupt vector/label for 1 page, 16 pages in total (16-page mode) |
| | DEFPAGE 32 | 64 interrupt vector/label for 1 page, 32 pages in total (32-page mode) |
| Operation mode | NORMAL | Normal mode operation |
| | CPU | CPU mode operation |
| Oscillator frequency | OSC_3MHz | 3 MHz oscillator |
| | OSC_1.5MHz | 1.5 MHz oscillator |
| Voice output type | VOUT_DAC | DAC (AUD) output |
| | VOUT_PWM | PWM output |

"DEFPAGE" determines the page operation mode in W523Axxx. The default setting of the page mode is 1-page mode. The 8-page, 16-page or 32-page mode can be declared to extend the voice group entry from 256 to 2047 in *PowerSpeech™* program.

The W523Axxx can communicate with an external microprocessor through the simple serial CPU



interface, which is the same as the W583Sxx series. The CPU interface consists of the TG1, TG2, and STPA/BUSY pins. "NORMAL" and "CPU" decide whether the operation mode of W523Axxx will be normal mode or CPU mode.

"OSC_3MHz" and "OSC_1.5MHz" select the frequency of the system clock. "VOUT_DAC" and "VOUT_PWM" select the voice output type.

Interrupt Vector Allocation

The W523Axxx provides a total of 4 trigger inputs to communicate with the outside world. Each trigger pin can invoke 2 dedicate interrupt vectors depending on TG pins' status (rising or falling). The table below shows the relationship between triggers' status and interrupt vectors.

For W523A008 and W523A010:

| INTERRUPT VECTOR | TRIGGER SOURCE |
|------------------|----------------|
| 0 | TG1F |
| 1 | TG2F |
| 2 | TG3F |
| 3 | TG4F |
| INTERRUPT VECTOR | TRIGGER SOURCE |
| 4 | TG1R |
| 5 | TG2R |
| 6 | TG3R |
| 7 | TG4R |
| 32 | POI |

For W523A012 ~ W523A120:

| INTERRUPT VECTOR | TRIGGER SOURCE |
|------------------|----------------|
| 0 | TG1F |
| 1 | TG2F |
| 8 | TG5F |
| 9 | TG6F |
| INTERRUPT VECTOR | TRIGGER SOURCE |
| 4 | TG1R |
| 5 | TG2R |
| 12 | TG5R |
| 13 | TG6R |
| 32 | POI |



CPU Interface

The W523Axxx can communicate with an external microprocessor through a simple serial CPU interface. The CPU interface consists of TG1, TG2 and STPA/BUSY pins, which are shown below:

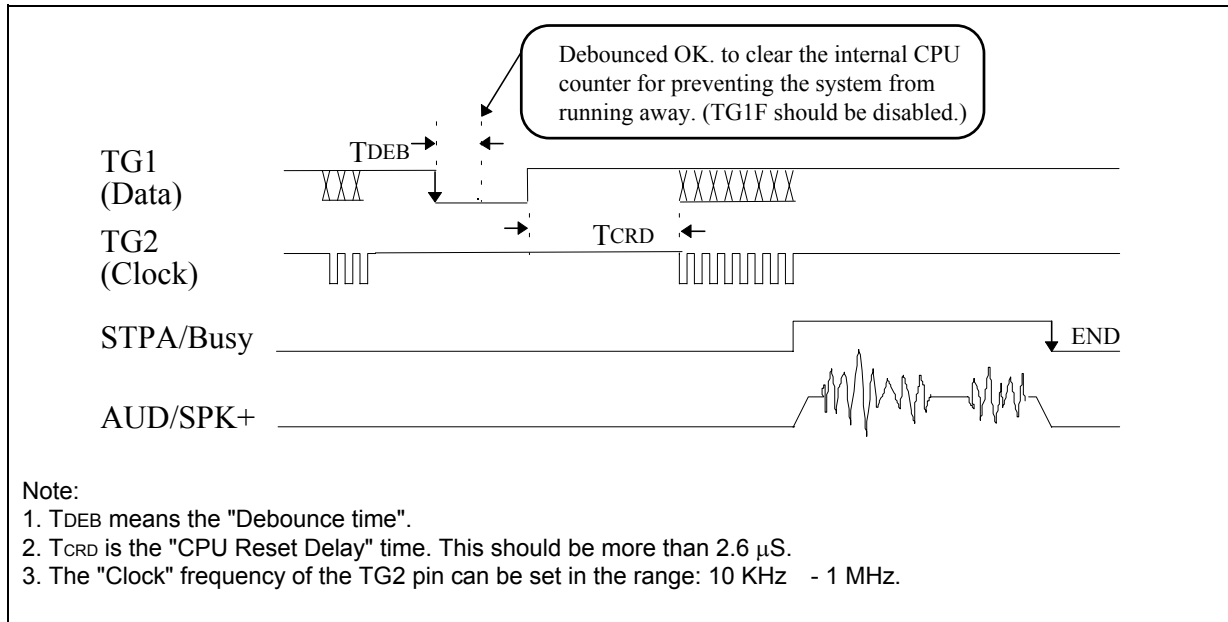

Busy signal will output "high" after the end of transmission. The rising timing of Busy signal is dependent on the MSB of data output on TG1 (Data) pin. If MSB is "1", Busy will rise after the last rising edge of TG2 (Clock) pin. If MSB is "0", Busy will rise after the rising edge that TG1 (Data) returns to high.

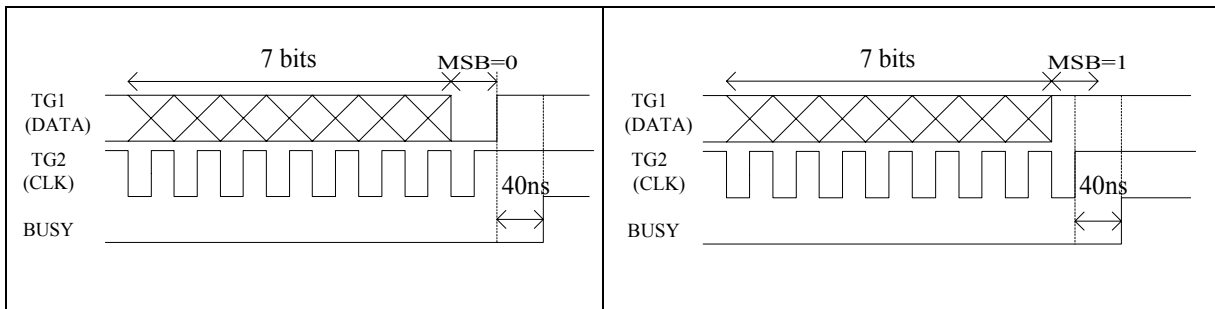

To place the W523Axxx in CPU mode, program the code according to the following example.



```

W523A015
CPU; Reserved word, used as a directive to notify the compiler for post processing.
LED1
FREQ2
POI:
    LD MODE0,XX1XX0XXB ;bit2=0 BUSY
    LD EN0, 0x00
    H5+voice1+T5
    END
34: ; Direct trigger or CPU interrupt.
    H5+voice2+T5
    END
    
```

The defaulted operating mode in W523Axxx is normal mode (or manual trigger mode), which is identified by the "Normal" and "CPU" option control. To enter the CPU mode, the "CPU" declaration must be inserted in the declaration region of program (*.out). In CPU mode, the bit MODE0.2, which is defined as STPA or BUSY selection for the STPA/BUSY pin, will be selected as "0" (BUSY output) automatically by the compiler unless otherwise specified explicitly by the STPA directive. The CPU, STPA, and BUSY directives can appear only in the first paragraph of the *.out files so that the compiler will automatically interpret them as Stop definitions in the POI interrupt vector. If these directives are placed elsewhere, an error message will be issued during the compilation process.

In the program example shown above, the external μC will transfer one byte data "34" to W523Axxx. The number 34 (Decimal) is equal to 00100010b (Binary). The interface timing is shown below.

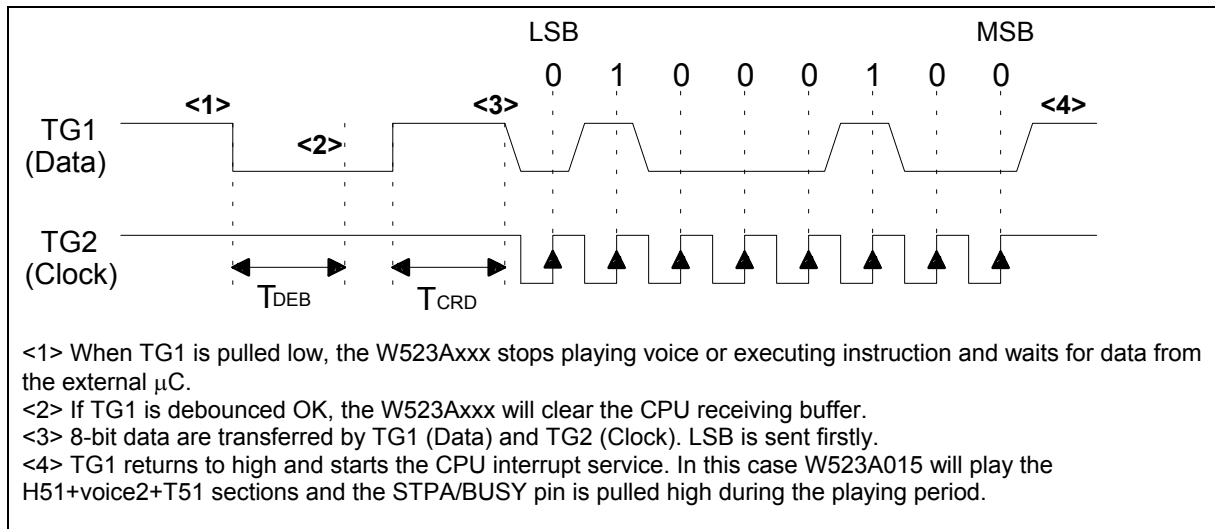

The TG1 pin, which is pulled high with a 500K Ω resistor, should be kept high during non-transmission periods to reduce power consumption. The external μC should be connected to the W523Axxx by an inverted-type output port for better noise immunity. In CPU mode, the W523Axxx stops operating upon the falling edge of the TG1 pin. For the CPU interface to work normally, TG1F should be disabled. Thus, one suggestion is that TG1F, TG1R, TG2F, and TG2R should all be disabled in CPU mode. The master frequency of the external μC , and hence the clock rate of TG1 and TG2, tends to vary among



different vendors and applications.

Note: In CPU mode application, in case the last voice group entry point, 255, is no used, it should be typed "END" command to avoid abnormal operating.

Instruction Set List

There are two types of instruction in the W523Axxx, unconditional and conditional instructions. The first types of instructions are executed immediately after they are issued. The second types of instructions are executed only when the conditions specified in the instruction are satisfied. All the instructions are listed in the following table. The cycle time for each instruction is $2/\text{Sampling Frequency (Fs)}$. For example, $F_s = 6.0 \text{ KHz}$, the cycle time is $333 \mu\text{s}$.

| UNCONDITIONAL | | CONDITIONAL | | |
|---------------|--------------|-------------|--------------|------|
| JP | G | JP | G | @STS |
| JP | Rn | JP | Rn | @STS |
| LD | EN0, value | LD | EN0, value | @STS |
| LD | EN1, value | LD | EN1, value | @STS |
| LD | MODEi, value | LD | MODEi, value | @STS |
| LD | STOP, value | LD | STOP, value | @STS |
| LD | PAGE, value | LD | PAGE, value | @STS |
| LD | Rn, value | LD | Rn, value | @STS |
| END | | END | | @STS |
| MV | Rn, Rm | MV | Rn, Rm | @STS |
| INC | | INC | | @STS |

Legend:

G: Interrupt vector/label

Rn: R0-R3

Rm: R0-R3

MODEi: MODE0, MODE1

value: 8-bit data

@STS can be the following: @LAST, @TGn_HIGH, @TGn_LOW, n = 1-4 (W523A008, W523A010), n = 1,2,5,6 (W523A012~A120).

ABSOLUTE MAXIMUM RATINGS

| PARAMETER | SYMBOL | CONDITIONS | RATED VALUE | UNIT |
|-----------------|---------|------------|----------------------|------|
| Power Supply | VDD-VSS | - | -0.3 to +7.0 | V |
| Input Voltage | VIN | All Inputs | VSS -0.3 to VDD +0.3 | V |
| Storage Temp. | TSTG | - | -55 to +150 | °C |
| Operating Temp. | TOPR | - | 0 to +70 | °C |

Note: Exposure to conditions beyond those listed under Absolute Maximum Ratings may adversely affect the life and reliability of the device.

ELECTRICAL CHARACTERISTICS

($T_A = 25^\circ \text{C}$, $V_{SS} = 0\text{V}$)



DC CHARACTERISTICS

| PARAMETER | SYM. | CONDITIONS | MIN. | TYP. | MAX. | UNIT |
|-------------------------------|------|--|-----------|------|-----------|------|
| Operating Voltage | VDD | DAC output | 2.4 | 3.0 | 5.5 | V |
| | | PWM output | 2.4 | 3.0 | 5.5 | V |
| Input Voltage | VIL | | VSS - 0.3 | - | 0.3 × VDD | V |
| | VIH | | 0.7 × VDD | - | VDD | |
| Standby Current | ISB1 | VDD = 3V, All I/O pins unconnected, No Playing | | | 1 | μA |
| | ISB2 | VDD = 5V, All I/O pins unconnected, No Playing | | | 1 | μA |
| Operating Current (Ring type) | IOP1 | VDD = 3V, No Load | | | 500 | μA |
| | IOP2 | VDD = 5V, No Load | | | 1 | mA |
| Input Current of TG pins | IIN1 | VDD = 3V, Vin = 0V | | | -8 | μA |
| Input Current of TEST pin | IIN2 | VDD = 3V, Vin = 3V | | | 30 | μA |
| Input Current of SEL, RESET | IIN3 | VDD = 3V, Vin = 0V | | | -8 | μA |
| SPK (D/A Full Scale) | IDAC | VDD = 4.5V, RI = 100Ω | -4.0 | -5.0 | -6.0 | mA |
| Output Current of STPA-STPE | IOL1 | VDD = 3V, Vout = 0.4V | 0.8 | | | mA |
| | IOH1 | VDD = 3V, Vout = 2.7V | -0.8 | | | mA |
| Output Current of SPK+, SPK- | IOL2 | VDD = 3V, RI = 8Ω | 100 | | | mA |
| | IOH2 | | -100 | | | mA |

AC CHARACTERISTICS

| PARAMETER | SYM. | CONDITIONS | MIN. | TYP. | MAX. | UNIT |
|--|------------------------------------|--------------------------------|------|------|------|------|
| Oscillation Frequency (W58300 ICE chip) | Fosc1 | Ring oscillator, Rosc = 270 KΩ | 2.7 | 3 | 3.3 | MHz |
| | | Ring oscillator, Rosc = 560 KΩ | 1.3 | 1.5 | 1.7 | MHz |
| Oscillation Frequency (W523Axxx production chip) | Fosc2 | Ring Oscillator, Rosc = 1.2 MΩ | 2.7 | 3 | 3.3 | MHz |
| | | Ring Oscillator, Rosc = 2.4 MΩ | 1.3 | 1.5 | 1.7 | MHz |
| Oscillation Frequency Deviation by Voltage Drop | $\frac{\Delta F_{osc2}}{F_{osc2}}$ | $\frac{F(3V)-F(2.4V)}{F(3V)}$ | | | 7.5 | % |



| | | | | | | |
|------------------------|-------|--------------------------|-----|-----|--|----|
| Instruction Cycle Time | Tins | Fosc = 3 MHz, SR = 6 KHz | | 1/3 | | mS |
| POI Delay Time | TPD | Fosc = 3 MHz | | 160 | | mS |
| Long Debounce Time | TDEBL | Fosc = 3 MHz, SR = 6 KHz | 50 | | | mS |
| Short Debounce Time | TDEBS | | 400 | | | μS |

BONDING PAD DIAGRAM

(For W523A008 and W523A010 only)

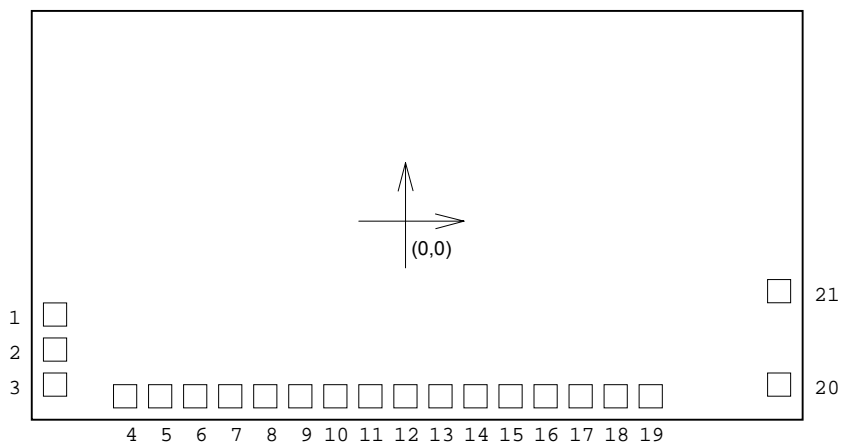

| PAD NO. | PAD NAME | PAD NO. | PAD NAME |
|---------|----------|---------|-----------|
| 1 | VDD | 12 | LED1 |
| 2 | OSC | 13 | STPA/BUSY |
| 3 | X | 14 | STPB |
| 4 | TEST | 15 | LED2/STPC |
| 5 | RESET | 16 | STPD |
| 6 | TG1 | 17 | STPE |
| 7 | TG2 | 18 | VSS1 |
| 8 | TG3 | 19 | VDD1 |
| 9 | TG4 | 20 | SPK- |
| 10 | VSS | 21 | AUD/SPK+ |
| 11 | NC | - | - |

NC means "No Connection"

W523AXXX



(For W523A012 ~ W523A120)

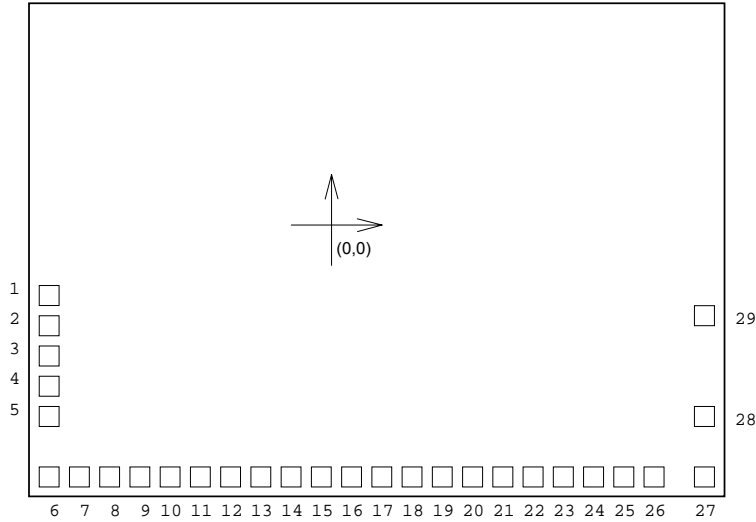

| PAD NO. | PAD NAME | PAD NO. | PAD NAME |
|---------|---------------------------|---------|-----------|
| 1 | VDD | 16 | NC |
| 2 | OSC | 17 | LED1 |
| 3 | NC | 18 | STPA/BUSY |
| 4 | NC | 19 | STPB |
| 5 | TEST | 20 | LED2/STPC |
| 6 | $\overline{\text{RESET}}$ | 21 | STPD |
| 7 | TG1 | 22 | STPE |
| 8 | TG2 | 23 | NC |
| 9 | NC | 24 | NC |
| 10 | NC | 25 | NC |
| 11 | TG5 | 26 | VSS1 |
| 12 | TG6 | 27 | VDD1 |
| 13 | NC | 28 | SPK- |
| 14 | NC | 29 | AUD/SPK+ |
| 15 | VSS | - | - |

NC: means "No Connection"

TYPICAL APPLICATION CIRCUIT

DAC output:

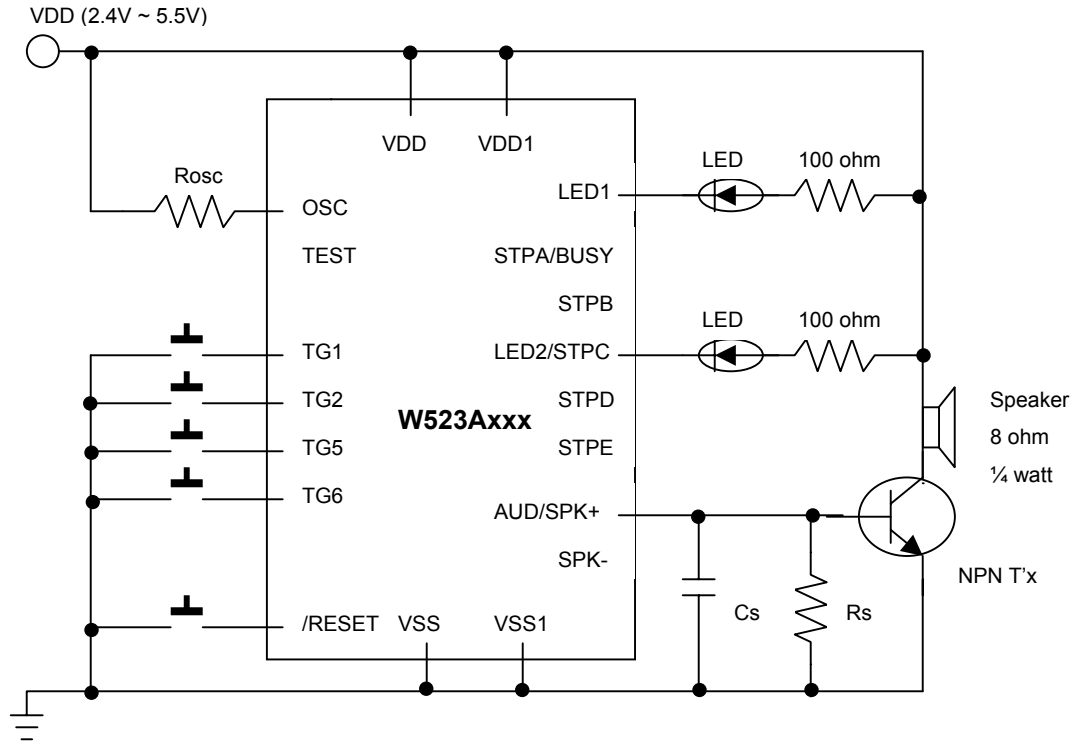

Note:

1. In principle, the playing speed determined by R_{osc} should correspond to the sampling rate during the coding phase. The playing speed may be adjusted by varying R_{osc} , however.
2. R_s is an optional current-dividing resistor. If R_s is added, the resistance should be between 390 and 820 ohm.
3. The typical $R_{osc} = 750 \text{ Kohm}$ for 3 MHz F_{osc} ; and $R_{osc} = 1.6 \text{ Mohm}$ for 1.5 MHz F_{osc} .
4. C_s is optional.
5. The DC current gain of the NPN transistor ranges from 120 to 200.
6. All unused trigger pins can be left open because of their internal pull-high resistance.
7. The OSC layout in customer's PCB should be as closed as the OSC pad to avoid noise coupling.
8. The chip's substrate must be wired to V_{ss} .
9. W523A008~A010's trigger pins are TG1, TG2, TG3, TG4; W523A012~W523A120's trigger pins are TG1, TG2, TG5, TG6.

PWM output:

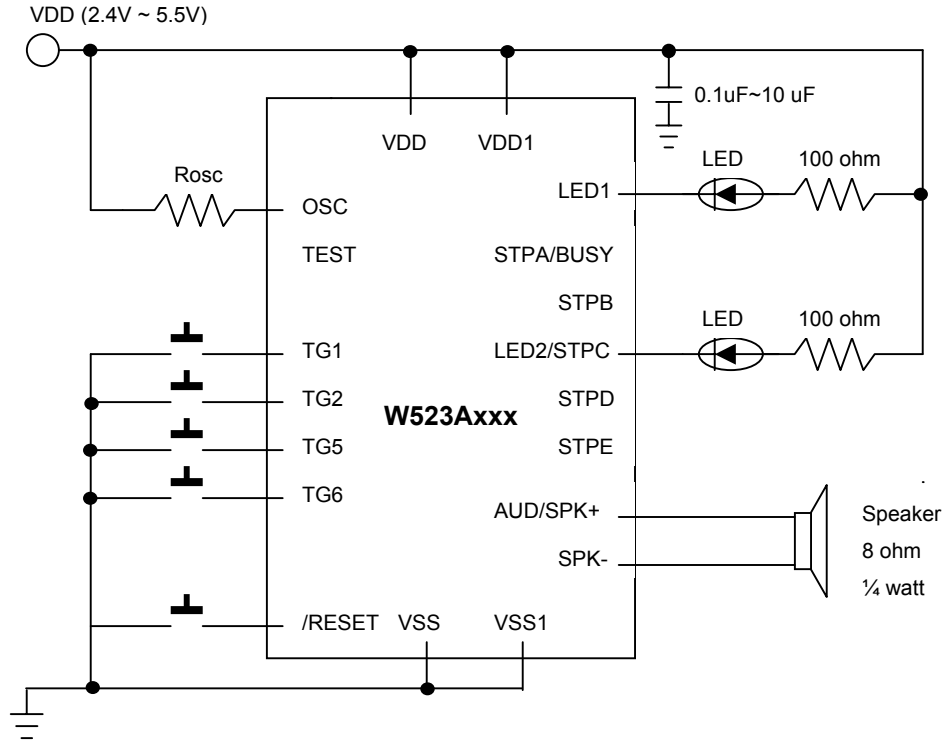

Note:

1. In principle, the playing speed determined by Rosc should correspond to the sampling rate during the coding phase. The playing speed may be adjusted by varying Rosc, however.
2. The typical Rosc = 750 Kohm for 3 MHz Fosc; and Rosc = 1.6 Mohm for 1.5 MHz Fosc.
3. The capacity, 0.1uF~10 uF, is necessary to reduce voltage fluctuation while PWM outputting.
4. All unused trigger pins can be left open because of their internal pull-high resistance.
5. The OSC layout in customer's PCB should be as closed as the OSC pad to avoid noise coupling.
6. The chip's substrate must be wired to Vss.
7. W523A008~A010's trigger pins are TG1, TG2, TG3, TG4; W523A012~W523A120's trigger pins are TG1, TG2, TG5, TG6.



Revision History in W523Axxx Data Sheet

| Version | Date | Editor | Description |
|---------|------------|------------|--|
| A1 | Dec-1-2001 | Steven Lin | Initial Issued |
| A2 | Feb-6-2002 | Steven Lin | <ul style="list-style-type: none">● Page 1, line 6, "14 kinds of bodies" → "14 kinds of part numbers".● Page1, line 7, Note: "by 6.4K..." → "by various..." |



Headquarters

No. 4, Creation Rd. III,
Science-Based Industrial Park,
Hsinchu, Taiwan
TEL: 886-3-5770066
FAX: 886-3-5665577
<http://www.winbond.com.tw/>

Taipei Office

9F, No.480, Rueiguang Rd.,
Neihu Chiu, Taipei, 114,
Taiwan, R.O.C.
TEL: 886-2-8177-7168
FAX: 886-2-8751-3579

Winbond Electronics Corporation America

2727 North First Street, San Jose,
CA 95134, U.S.A.
TEL: 1-408-9436666
FAX: 1-408-5441798

Winbond Electronics Corporation Japan

7F Daini-ueno BLDG, 3-7-18
Shinyokohama Kohoku-ku,
Yokohama, 222-0033
TEL: 81-45-4781881
FAX: 81-45-4781800

Winbond Electronics (Shanghai) Ltd.

27F, 2299 Yan An W. Rd. Shanghai,
200336 China
TEL: 86-21-62365999
FAX: 86-21-62365998

Winbond Electronics (H.K.) Ltd.

Unit 9-15, 22F, Millennium City,
No. 378 Kwun Tong Rd.,
Kowloon, Hong Kong
TEL: 852-27513100
FAX: 852-27552064

*Please note that all data and specifications are subject to change without notice.
All the trade marks of products and companies mentioned in this data sheet belong to their respective owners.*