

Analog LCD Display Engine for XGA and SXGA Resolutions with Embedded LVDS and RSDS Transmitters

DATABRIEF

Feature Overview

- Programmable Context Sensitive™ Filtering
- High-quality Up-scaling and Down-scaling
- Integrated 10-bit Triple Channel ADC/PLL
- IQSync™ AutoSetup
- Integrated Programmable Timing Controller
- Integrated LVDS Transmitters
- Integrated Pattern Generator
- Perfect Picture™ Technology
- sRGB 3D Color Warp
- High performance OSD supporting 1- to 4-bpp, proportional fonts
- Advanced EMI reduction features
- Serial I²C interface

- Low power 0.15 μm process technology
- Low cost 100-pin LQFP and 128-pin LQFP packages
- Lead-free versions available in 2005.

General Description

ADE3800 devices are a family of highly-integrated display engine ICs, enabling the most advanced, flexible, and cost-effective system-on-chip solutions for analog-only input LCD display applications.

The ADE3800 covers the full range of XGA and SXGA analog-only monitor applications using LVDS or RSDS interface.

The ADE3800 family is software compatible.

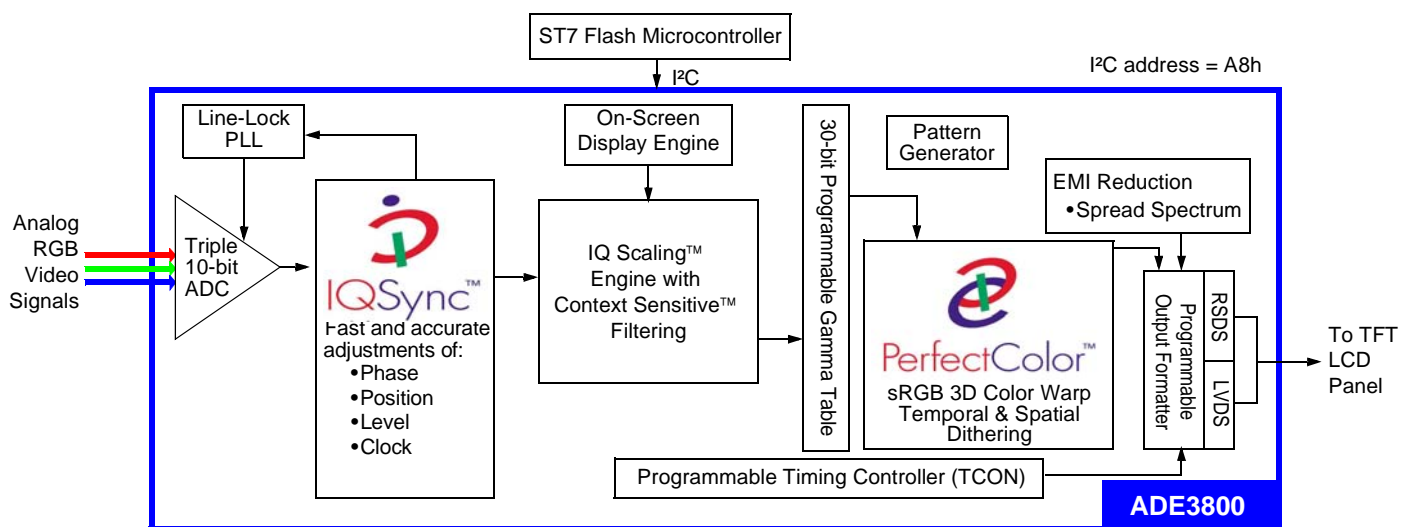

LCD Scaler Product Selector

Product	Package	Output Format Support		
		Resolution	RSDS/TCON	LVDS
ADE3800XL	100 LQFP	Up to XGA 75 Hz		Yes
ADE3800XT	100 LQFP	Up to XGA 75 Hz	Yes	
ADE3800SXL	100 LQFP	Up to SXGA 75 Hz		Yes
ADE3800SXT	128 LQFP	Up to SXGA 75 Hz	Yes	

Context Sensitive™ Scaler

- Sharper text with Edge Enhancement
- Programmable coefficients for unique customization
- From 5:1 upscale to 2:1 downscale
- Independent X - Y axis zoom and shrink

Analog RGB input

- 140 MHz 10-bit ADC
- Ultra low jitter digital Line Lock PLL
- Composite Sync and Sync on Green built-in support

IQsync™ AutoSetup

- AutoSetup configures phase, clock, level, and position
- Automatically detects activity on input
- Compatible with all standard VESA and GTF modes

Perfect Picture™ Technology

- Video & Picture highlight zone
- Supports up to 4 different windows
- Independent window controls for contrast brightness and color

Perfect Color™ Technology

- Programmable 3D Color Warp
- Digital brightness, contrast, hue, and saturation gamma controls
- Simple white point control
- Compatible with sRGB standard
- True color dithering for 18 and 24-bit panels
- Temporal and spatial dithering
- 30-bit programmable gamma table

OSD Engine

- 12 KB RAM based 12x18 characters
- 1, 2, 3, 4-bit per pixel color characters
- Multiple Windows
- Bordering, shadowing, transparency, fade-in and fade-out effects

- Supports font rotation
- Up to full screen size, multiple windows
- 64-entry TrueColor LUT with alpha-blending

Programmable Timing Controller (TCON)

- Highly programmable support for XGA and SXGA smart panels
- RSDS split line support for SXGA smart panels
- Supports 18, 24, 36, and 48-bit RSDS outputs
- Advanced Flicker Detection and Reduction
- 8 programmable timing signals for row/column control
- Wide range of drivers & TCON compatibility

Integrated LVDS Transmitters

- Dual 4 channel 6/8 bit LVDS transmitters
- Programmable channel swapping
- Programmable channel polarity
- Programmable group channel swapping for flexibility in board layout
- Programmable output swing control

Advanced EMI Reduction Features

- Flexible data transition minimization, single and dual
- Differential clock and signals
- Spread spectrum - programmable digital FM modulation of the output clock with no external components

Output Format

- Supports resolutions up to SXGA @ 75Hz
- Supports resolution above SXGA (1280x1024) with convenient input and output pixel clocks
- Supports 6 or 8-bit Panels
- Supports single or double pixel wide formats

Information furnished is believed to be accurate and reliable. However, STMicroelectronics assumes no responsibility for the consequences of use of such information nor for any infringement of patents or other rights of third parties which may result from its use. No license is granted by implication or otherwise under any patent or patent rights of STMicroelectronics. Specifications mentioned in this publication are subject to change without notice. This publication supersedes and replaces all information previously supplied. STMicroelectronics products are not authorized for use as critical components in life support devices or systems without express written approval of STMicroelectronics.

The ST logo is a registered trademark of STMicroelectronics

All other names are the property of their respective owners

© 2004 STMicroelectronics - All rights reserved

STMicroelectronics GROUP OF COMPANIES

Australia - Belgium - Brazil - Canada - China - Czech Republic - Finland - France - Germany - Hong Kong - India - Israel - Italy
- Japan - Malaysia - Malta - Morocco - Singapore - Spain - Sweden - Switzerland - United Kingdom - United States

www.st.com