

TENTATIVE TOSHIBA BIPOLAR LINEAR INTEGRATED CIRCUIT SILICON MONOLITHIC

TA1303BFN**MIXER / OSCILLATOR BUILT-IN FREQUENCY SYNTHESIZER FOR VHF, CATV AND UHF BAND.**

The TA1303BFN is a single chip which integrates a PLL and a MIX-OSC for VHF, CATV and UHF band.

The control data conforms to 3-wire bus and I²C bus formats. Bus-SW can be used to easily switch for easy tuner system set-up.

Flat, compact package : SSOP30 (0.65 mm pitch)

FEATURES**MIX-OSC block**

- VHF · CATV bands : Mixer and Oscillator
- UHF bands : Mixer and Oscillator
- Built-in IF amplifier
- Single IF output terminal

PLL block

- Standard bi-directional I²C bus format control
- 3-wire bus format control
- 18-bit and 19-bit automatical discrimination circuit (when 3-wire bus selected)
- Tuning amplifier
- 4-bit bandswitch drive transistor
- 5-levels A/D convertor (when I²C bus selected)
- Frequency step : 31.25 kHz, 50 kHz and 62.5 kHz (at 4 MHz X'tal used)
- 4 programmable chip addresses (when I²C bus selected)
- Power on reset circuit
- 1/4 prescaler

(Note) These devices are easy to be damaged by high static voltage or electric fields.
In regard to this, please handle with care.

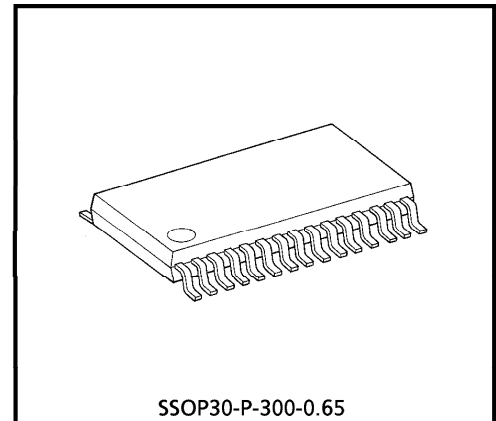

Weight : 0.17 g (Typ.)

980910EBA1

- TOSHIBA is continually working to improve the quality and the reliability of its products. Nevertheless, semiconductor devices in general can malfunction or fail due to their inherent electrical sensitivity and vulnerability to physical stress. It is the responsibility of the buyer, when utilizing TOSHIBA products, to observe standards of safety, and to avoid situations in which a malfunction or failure of a TOSHIBA product could cause loss of human life, bodily injury or damage to property. In developing your designs, please ensure that TOSHIBA products are used within specified operating ranges as set forth in the most recent products specifications. Also, please keep in mind the precautions and conditions set forth in the TOSHIBA Semiconductor Reliability Handbook.
- The products described in this document are subject to the foreign exchange and foreign trade laws.
- The information contained herein is presented only as a guide for the applications of our products. No responsibility is assumed by TOSHIBA CORPORATION for any infringements of intellectual property or other rights of the third parties which may result from its use. No license is granted by implication or otherwise under any intellectual property or other rights of TOSHIBA CORPORATION or others.
- The information contained herein is subject to change without notice.

BLOCK DIAGRAM

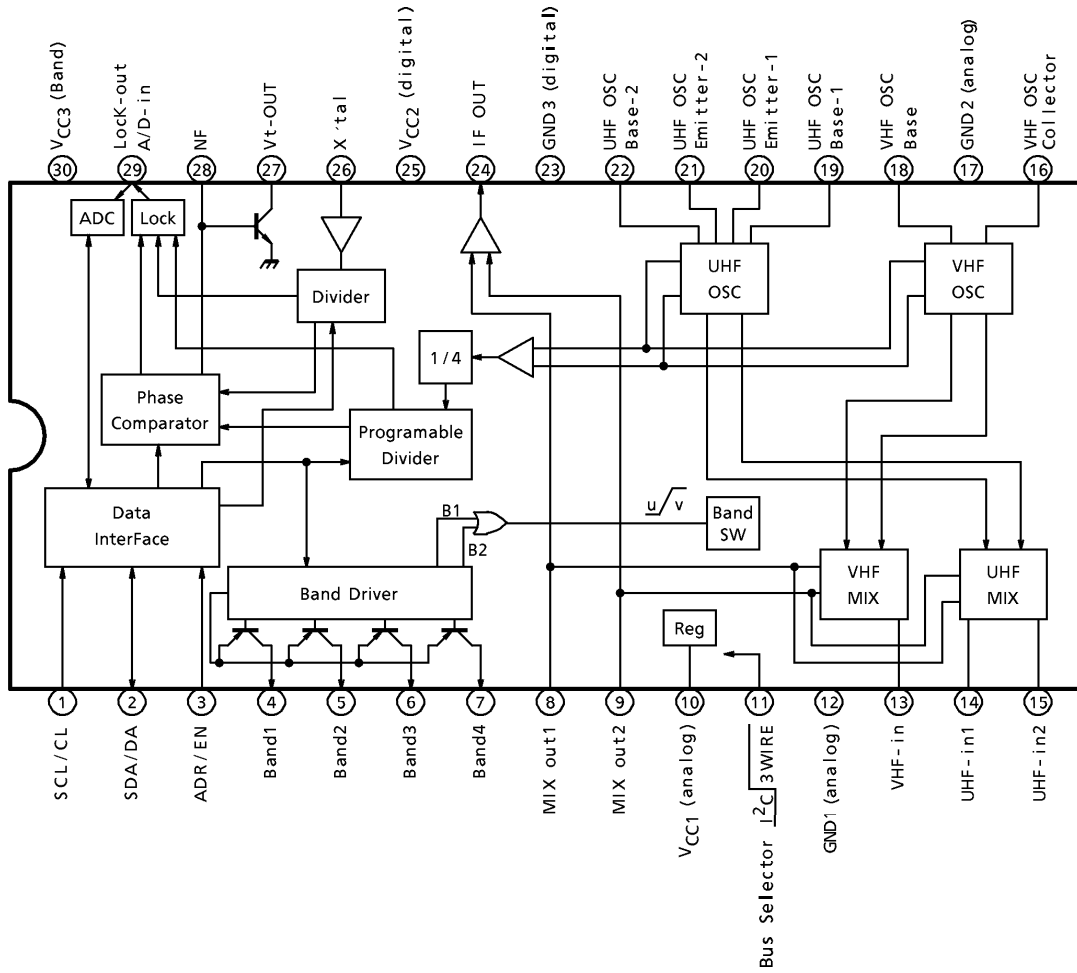

TERMINAL FUNCTION

PIN No.	PIN NAME	FUNCTION	INTERFACE
1	CL/SCL	3-wire bus : clock data input I ² C bus : serial clock data input Please refer the description (Table. 1) on page 13.	
2	DA/SDA	3-wire bus : data input I ² C bus : serial data input / output Please refer the description (Table. 1) on page 13.	
3	EN/ADR	3-wire bus : enable data input I ² C : address select input Please refer the description (Table. 1) on page 13.	
30	VCC3	This is power supply pin for Band circuits. This can use, from 5 V to 9 V.	
4 5 6 7	Band1~Band4	Output can be controlled by setting the band switch data. U/V band can be switched by setting the band switch data. Please refer the description (Table. 5) on page 21.	

PIN No.	PIN NAME	FUNCTION	INTERFACE
8 9	MIX Output	The output terminal of MIXER. For tuning, connect a tank circuit between pins 8 and 9.	
10	VCC1	This is power supply pin for analog circuit	—
11	BUS-SW	A changeover switch of control data. 3-wire bus and standard I ² C bus are switches by the voltage applied on this pin. Please refer the description (Table. 1, 2) on page 13 and 14.	
12	GND1	This is the ground pin for analog circuit.	—
13	VHF Input	VHF-RF input.	
14 15	UHF Input	UHF-RF input. It is possible to input either balanced or unbalanced circuit.	
16 18	VHF Oscillator	VHF oscillator pins. In case of production abnormal oscillation, connect a resistor between pin 1 and the external capacitor.	
17	GND2	This is the ground pin for analog circuit.	—

PIN No.	PIN NAME	FUNCTION	INTERFACE
19 20 21 22	UHF Oscillator	UHF oscillator pins. They are colpitts oscillator.	
23	GND2	This is the ground pin for digital circuit.	—
24	IF Output	Output terminal of IF signal which output impedance, 75 Ω.	
25	VCC2	This is power supply pin for digital circuit.	—
26	X'tal	Crystal oscillator input. At this block, the reference signal is generated.	
27	Charge Pump Output	Tuning voltage output terminal. This LSI has a built-in tuning amplifier.	
28	NF		

PIN No.	PIN NAME	FUNCTION	INTERFACE
29	ADC/ $\overline{\text{LOCK}}$	<p>At 3 wire bus mode : this functions as lock detector. If the PLL has locked, the output becomes low.</p> <p>At I²C bus mode : this functions as terminal of AD convertor.</p> <p>This converts the input voltages into proper digital data. Please refer the description (Table. 6) on page 21.</p>	

MAXIMUM RATINGS (Ta = 25°C)

CHARACTERISTIC	SYMBOL	RATING	UNIT
MIX-OSC Block	V _{CC1}	6	V
	f _{IN}	120	dB μ V
PLL Block	V _{CC2}	6	V
	V _{CC3}	12	V
	V _{BT}	38	V
Power Dissipation	PD	780 [IC only] (Note)	mW
Operating Temperature	T _{opr}	- 20~85	°C
Storage Temperature	T _{stg}	- 55~150	°C

(Note) When using the device at above Ta = 25°C, decrease the power dissipation by 6.3 mW for each increase of 1°C.

RECOMMENDED OPERATING CONDITION

PIN No.	SYMBOL	MIN.	TYP.	MAX.	UNIT	
10	MIX-OSC block	V _{CC1}	4.5	5	5.5	V
25	PLL block	V _{CC2}	4.5	5	5.5	V
30		V _{CC3}	V _{CC2}	—	9.9	V

ELECTRICAL CHARACTERISTICS

PC CHARACTERISTICS (Unless otherwise specified, $V_{CC1} = 5V$, $V_{CC2} = 5V$, $V_{CC3} = 9V$, $T_a = 25^\circ C$)

CHARACTERISTIC		SYMBOL	TEST CIR-CUIT	BAND	TEST CONDITION	MIN.	TYP.	MAX.	UNIT
Power Supply and Current 1		I _{CC1-1}	1	VHF	—	24	32	40	mA
		I _{CC1-2}		UHF	—	26	34	43	
Power Supply and Current 2		I _{CC2}		—	—	12	16	21	
Power Supply and Current 3		I _{CC3-1}		—	Band switch : 1 Band ON IBD = 30 mA (LOAD)	—	34	36	
		I _{CC3-2}		—	Band switch : 2 Band ON IBD = 40 mA (TOTAL LOAD)	—	48	52	
Terminal Voltage	PIN 8	V8-V	1	VHF	—	3.6	4.1	4.6	V
		V8-U		UHF	—	3.4	3.9	4.4	
	PIN 9	V9-V		VHF	—	3.6	4.1	4.6	
		V9-U		UHF	—	3.4	3.9	4.4	
	PIN 13	V13-V		VHF	—	1.8	2.1	2.4	
		V13-U		UHF	—	2.0	2.2	2.5	
	PIN 14	V14-V		VHF	—	2.0	2.2	2.5	
		V14-U		UHF	—	1.7	2.0	2.4	
	PIN 15	V15-V		VHF	—	2.0	2.2	2.5	
		V15-U		UHF	—	1.7	2.0	2.4	
	PIN 16	V16-V		VHF	—	2.3	2.7	3.0	
		V16-U		UHF	—	3.8	4.1	4.4	
	PIN 18	V18-V		VHF	—	1.7	2.2	2.7	
		V18-U		UHF	—	2.6	2.9	3.1	
	PIN 19	V19-V		VHF	—	2.5	2.7	2.9	
		V19-U		UHF	—	2.1	2.4	2.7	
	PIN 20	V20-V		VHF	—	1.9	2.2	2.5	
		V20-U		UHF	—	1.4	1.7	2.0	
	PIN 21	V21-V		VHF	—	1.9	2.2	2.5	
		V21-U		UHF	—	1.4	1.7	2.0	
	PIN 22	V22-V		VHF	—	2.5	2.7	2.9	
		V22-U		UHF	—	2.1	2.4	2.7	
	PIN 24	V24		—	—	1.9	2.3	2.6	

ELECTRICAL CHARACTERISTICS

MIX·OSC block (Unless otherwise specified, $V_{CC1} = 5V$, $V_{CC2} = 5V$, $V_{CC3} = 9V$, $T_a = 25C^\circ$)

CHARACTERISTIC	SYMBOL	TEST CIR-CUIT	BAND	TEST CONDITION (*)	MIN.	TYP.	MAX.	UNIT
Conversion Gain (Note 1)	CG	3	VHF	$f_{RF} = 55.25 \text{ MHz}$	21	24	27	dB
			VHF	$f_{RF} = 367.25 \text{ MHz}$	21	24	27	
			UHF	$f_{RF} = 373.25 \text{ MHz}$	25	28	31	
			UHF	$f_{RF} = 801.25 \text{ MHz}$	25	28	31	
Noise Figure (Note 2)	NF	3	VHF	$f_{RF} = 55.25 \text{ MHz}$	—	11	13	dB
			VHF	$f_{RF} = 367.25 \text{ MHz}$	—	11	13	
			UHF	$f_{RF} = 373.25 \text{ MHz}$	—	8.5	11	
			UHF	$f_{RF} = 801.25 \text{ MHz}$	—	9.5	12	
IF Out Power Level (Note 3)	IFp	3	VHF	$f_{RF} = 55.25 \text{ MHz}$	6	8.5	—	dBmW
			VHF	$f_{RF} = 367.25 \text{ MHz}$	6	8.5	—	
			UHF	$f_{RF} = 373.25 \text{ MHz}$	6	8.5	—	
			UHF	$f_{RF} = 801.25 \text{ MHz}$	6	8.5	—	
Conversion Gain Shift (Note 4)	CGs	3	VHF	$f_{RF} = 55.25 \text{ MHz}$	—	—	± 0.5	dB
			VHF	$f_{RF} = 367.25 \text{ MHz}$	—	—	± 0.5	
			UHF	$f_{RF} = 373.25 \text{ MHz}$	—	—	± 0.5	
			UHF	$f_{RF} = 801.25 \text{ MHz}$	—	—	± 0.5	
Frequency Shift (The PLL is not operating) (Note 5)	Δf_B	3	VHF	$f_{osc} = 101 \text{ MHz}$	—	—	± 100	kHz
			VHF	$f_{osc} = 413 \text{ MHz}$	—	—	± 150	
			UHF	$f_{osc} = 419 \text{ MHz}$	—	—	± 150	
			UHF	$f_{osc} = 847 \text{ MHz}$	—	—	± 150	
Switching On Drift (The PLL is not operating) (Note 6)	Δf_s	3	VHF	$f_{osc} = 101 \text{ MHz}$	—	—	± 100	kHz
			VHF	$f_{osc} = 413 \text{ MHz}$	—	—	± 200	
			UHF	$f_{osc} = 419 \text{ MHz}$	—	—	± 150	
			UHF	$f_{osc} = 847 \text{ MHz}$	—	—	± 200	
1% Cross Modulation (Note 7)	CM	3	VHF	$f_D = 55.25 \text{ MHz}$	81	85	—	dB μ V
			VHF	$f_D = 367.25 \text{ MHz}$	80	84	—	
			UHF	$f_D = 373.25 \text{ MHz}$	76	80	—	
			UHF	$f_D = 801.25 \text{ MHz}$	76	80	—	
3rd Inter Modulation (Note 8)	IM3	3	VHF	$f_D = 55.25 \text{ MHz}$	49	54	—	dB
			VHF	$f_D = 367.25 \text{ MHz}$	50	55	—	
			UHF	$f_D = 373.25 \text{ MHz}$	38	45	—	
			UHF	$f_D = 801.25 \text{ MHz}$	38	45	—	
6-ch Beat (Note 9)	B6	3	VHF	$f_p = 83.25 \text{ MHz}$ $f_s = 87.75 \text{ MHz}$	49	50	—	dB
Prescaler Beat (Note 10)	Bpre	3	VHF	$f_{osc} = 167 \text{ MHz (A-ch),}$ 173 MHz (B-ch), 179 MHz (C-ch), 185 MHz (D-ch)	—	13	18	dB μ V

(*) IF : 45.75 MHz

PLL block (Unless otherwise specified, $V_{CC1} = 5\text{ V}$, $V_{CC2} = 5\text{ V}$, $V_{CC3} = 9\text{ V}$, $T_a = 25\text{ C}^\circ$)

CHARACTERISTIC	SYMBOL	TEST CIR-CUIT	TEST CONDITION	MIN.	TYP.	MAX.	UNIT
Bandswitch Drive Current	IBD	1	Maximum drive current / 1 port	—	—	30	mA
Bandswitch Drive Maximum LOAD	IBD _{MAX}	1	Maximum total drive current	—	—	50	mA
Bandswitch Drive Voltage Drop	VBD Sat	1	IBD = 30 mA	—	0.15	0.2	V
Tuning Amplifier Output Voltage (Close Loop)	Vt Out	—	$V_{BT} = 33\text{ V}$, $R_L = 33\text{ [k}\Omega\text{]}$	0.3	—	33	V
Tuning Amplifier Maximum Current	Ivt	—	$V_{BT} = 33\text{ V}$	—	—	3	mA
X'tal Negative Resistance	XtR	1		1	2.5	—	k Ω
X'tal Operating Range	OSC f_{in}	1	—	3.2	—	4.5	MHz
X'tal External Input Level	OSC _{in}	2	—	100	—	1000	mV _{p-p}
Lock Output Low Voltage	VLKL	1	(Lock mode, 3-wire bus mode)	—	—	0.4	V
Lock Output High Voltage	VLKH	1	(Unlock mode, 3-wire bus mode)	4.6	—	—	V
Logic Input Low Voltage	VBsL	1	Pins 1 to 3	-0.3	—	1.5	V
Logic Input High Voltage	VBsH	1	Pins 1 to 3	3	—	$V_{CC2} + 0.3$	V
Logic Input Current (Low)	IBsL	1	Pin 1	-20	—	10	μA
			Pin 3	-55	—	-20	
Logic Input Current (High)	IBsH	1	Pin 1, Pin 2	-10	—	20	
			Pin 3	75	—	150	
Bus-SW Low Input Voltage	VBIL	1	—	0	—	0.8	V
Bus-SW High Input Voltage	VBIH	1	—	4.2	—	V_{CC2}	
Bus-SW Low Current (Low)	IBIL	1	—	-200	—	—	μA
Bus-SW Low Current (High)	IBIH	1	—	—	—	200	μA
Charge Pump Output Current	Ichg	1	CP = 『 0 』	± 30	± 60	± 90	μA
			CP = 『 1 』	± 140	± 280	± 420	
ACK Output Voltage	VACK	1	$I_{SINK} = 3\text{ mA}$ (I ² C-bus mode)	—	—	0.4	V

CHARACTERISTIC	SYMBOL	TEST CIR-CUIT	TEST CONDITION	MIN.	TYP.	MAX.	UNIT
Set-up Time	T_S	—	(3-wire bus mode) Refer to data timing chart	2	—	—	μS
Enable Hold Time	T_{SL}			2	—	—	
Next Enable Stop Time	T_{NE}			6	—	—	
Next Clock Stop Time	T_{NC}			6	—	—	
Clock Width	T_C			2	—	—	
Enable Set-up Time	T_L			10	—	—	
Data Hold Time	T_H			2	—	—	
SCL Clock Frequency	f_{SCL}		(I ² C bus mode) Refer to data timing chart	0	—	100	kHz
Bus Free Time Between a STOP and START Condition	t_{BUF}			4.7	—	—	μS
Hold Time (Repeated) START Condition	$t_{HD;STA}$			4.0	—	—	
Low Period of the SCL Clock	t_{LOW}			4.7	—	—	
High Period of the SCL Clock	t_{HIGH}			4.0	—	—	
Set-up Time for a Repeated START Condition	$t_{SU;STA}$			4.7	—	—	
Data Hold Time	$t_{HD;DAT}$			0	—	—	
Data Set-up Time	$t_{SU;DAT}$	250		—	—	ns	
Rise Time of both SDA and SCL Signals	t_R	—		—	1000		
Fall Time of both SDA and SCL Signals	t_F	—		—	300		
Set-up Time for STOP Condition	$t_{SU;STO}$			4.0	—	—	μS

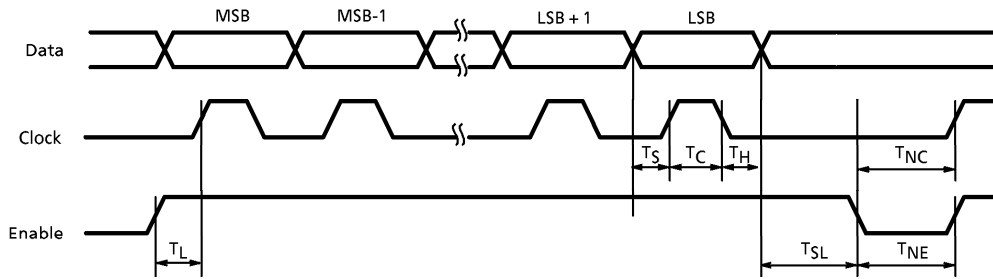

Fig.1 3-wire bus data timing chart (Falling edge timing)

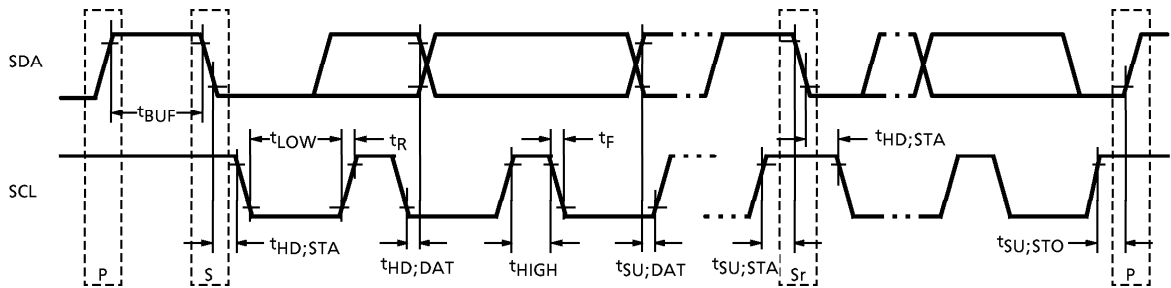

Fig.2 I²C bus data timing chart (Rising edge timing)

REFERENCE DATA ($V_{CC1} = 5V$, $V_{CC2} = 5V$, $V_{CC3} = 9V$, $T_a = 25C^\circ$)

CHARACTERISTIC	SYMBOL	TEST CIRCUIT	BAND	TEST CONDITION	MIN.	TYP.	MAX.	UNIT
			VHF	$f_{osc} = 179\text{ MHz} \rightarrow f_{osc} = 413\text{ MHz}$	—	60	—	
			UHF	$f_{osc} = 419\text{ MHz} \rightarrow f_{osc} = 847\text{ MHz}$	—	30	—	
Reference Leak Suppression Level	fref S/I	3	VHF	$f_{RF} = 55.25\text{ MHz}$ (−30 dBmW 入力) (CP = 「1」、fref = 15.625 kHz)	—	65	—	dB
			VHF	$f_{RF} = 367.25\text{ MHz}$ (−30 dBmW 入力) (CP = 「1」、fref = 15.625 kHz)	—	60	—	
			UHF	$f_{RF} = 373.25\text{ MHz}$ (−30 dBmW 入力) (CP = 「1」、fref = 15.625 kHz)	—	48	—	
			UHF	$f_{RF} = 801.25\text{ MHz}$ (−30 dBmW 入力) (CP = 「1」、fref = 15.625 kHz)	—	53	—	
Local Oscillator Leak Level (To IF Output) [Worst Case]	LOIF	3	VHF	$f_{osc} = 101\text{ MHz} \sim f_{osc} = 173\text{ MHz}$	—	−36	—	dBmW
			VHF	$f_{osc} = 179\text{ MHz} \sim f_{osc} = 413\text{ MHz}$	—	−36	—	
			UHF	$f_{osc} = 419\text{ MHz} \sim f_{osc} = 847\text{ MHz}$	—	−28	—	

TEST CONDITIONS

- (Note 1) Conversion Gain
 f_{RF} input level = -30 dBmW
- (Note 2) Noise Figure
 Noise Figure meter used.
- (Note 3) IF Out Power Level
 Measure IF output level when it is maximum level.
- (Note 4) Conversion Gain Shift
 The Conversion gain shift is defined as a change in conversion gain when supply voltage varies from $V_{CC} = 5$ to 4.5 V or from $V_{CC} = 5$ to 5.5 V.
- (Note 5) Frequency Shift (The PLL is not operating)
 The frequency shift is defined as a change in oscillator frequency when supply voltage varies from $V_{CC} = 5$ to 4.5 V or from $V_{CC} = 5$ to 5.5 V.
- (Note 6) Switching On Drift (The PLL is not operating)
 Measure frequency change from 2 seconds after switching on to 3 minutes.
- (Note 7) 1% Cross Modulation
- $f_d = f_p$ (f_{dRF} input level = -30 dBmW)
 - $f_{ud} = f_p + 12 \text{ MHz}$ 100 kHz, 30%AM
- Input two signals, and increase the f_{udRF} input level.
 Measure the f_{udRF} input level when the suppression level reaches 56.5 dB.
- (Note 8) 3rd Inter Modulation
- $f_d = f_p$ (f_{dRF} input level = -30 dBmW)
 - $f_{ud} = f_p + 1 \text{ MHz}$ (f_{udRF} input level = -30 dBmW)
- Input two signals, measure the suppression level.
- (Note 9) 6-ch Beat
- $f_p = 83.25 \text{ MHz}$ (f_{pRF} input level = -30 dBmW)
 - $f_s = 87.75 \text{ MHz}$ (f_{sRF} input level = -30 dBmW)
- Input two signals, measure the suppression level IF output signal between below signals.
- $$f_{udif1} = (f_p + f_s) - f_{osc} = (83.25 + 87.75) - 129 = 42 \text{ MHz}$$
- $$f_{udif2} = (2 \times f_s) - f_{osc} = (2 \times 87.75) - 129 = 46.5 \text{ MHz}$$
- (Note 10) Prescaler Beat
- $1/4 f_{osc}$ (A-ch) = $1/4 \times 167 = 41.75 \text{ MHz}$
 - $1/4 f_{osc}$ (B-ch) = $1/4 \times 173 = 43.25 \text{ MHz}$
 - $1/4 f_{osc}$ (C-ch) = $1/4 \times 179 = 44.75 \text{ MHz}$
 - $1/4 f_{osc}$ (D-ch) = $1/4 \times 185 = 46.25 \text{ MHz}$
- As for each channel, measure the level to IF output.

PLL BLOCK

Operation description

TA1303BFN can be controlled with either by 3-wire bus or standard I²C bus.

The 3-wire bus mode is equipped with an 18-bit/19-bit automatic selection circuit.

Frequency steps can be switched, depending on the voltage applied to the BUS-SW pin.

The I²C bus conforms to the standard I²C bus format. The bus supports two-way bus communications control, consisting of WRITE mode where data are received and READ mode where data are transmitted. In READ mode, the voltage applied on the A/D converter input pin can be transmitted and output with 5-level resolution. (This function is only valid when the I²C bus is selected. When the 3-wire bus is selected, the A/D converter input pin functions as the $\overline{\text{Lock}}$ output pin.)

Addresses can be set using the hardware bits. 4 programmable addresses are supported. 3-wire bus and standard I²C bus are switched by the voltage applied on the BUS-SW pin.

When the supply voltage (V_{CC2}) is applied, the power-on reset circuit operates. Before data are input, counter data are all initialized to '0'; band switches are all initialized to off.

Function chart

Table. 1

PIN NAME	3-WIRE BUS	I ² C BUS
BUS-SW	「 OPEN 」 or 「 V _{CC} 」	「 GND 」
CL / SCL	CLOCK INPUT	SCL INPUT
DA / SDA	DATA INPUT	SDA IN / OUTPUT
EN / ADR	ENABLE INPUT	ADDRESS
$\overline{\text{Lock}}$ / ADC	$\overline{\text{Lock}}$	ADC

- 3-Wire bus communications control

The 3-wire bus uses normal 18-bit and 19-bit data (band switch information and programmable divider information) and 27-bit test data (charge-pump current setting, tuning amplifier on/off, reference frequency divider ratio setting, and testing item functions) are available.

The program frequency is sequentially calculated together with normal data and test data.

$$f_{osc} = f_r \times 4 \times N$$

f_{osc} : Program frequency

f_r : Phase comparator reference frequency

N : Divider ratio

(1) Normal data

Depending on the voltage (OPEN, V_{CC}) applied on the BUS-SW pin and the transfer DATA bit length, the X'tal divider ratio setting, phase comparator reference frequency, and step frequency of the normal data are as shown in the table below.

Normal data function table
Table. 2

BUS-SW INPUT	TRANSFER DATA	X'TAL RATIO	REFERENCE FREQUENCY	STEP FREQUENCY
[V _{CC}]	18-bit	Cannot be set	—	—
[V _{CC}]	19-bit	1 / 320	12.5 kHz	50 kHz
[OPEN]	18-bit	1 / 256	15.625 kHz	62.5 kHz
[OPEN]	19-bit	1 / 512	7.8125 kHz	31.25 kHz

(Note 1) The step frequency at 4 MHz (X'tal used)

(Note 2) During OPEN, automatically set with transmitted bit length (18↔19 possible)

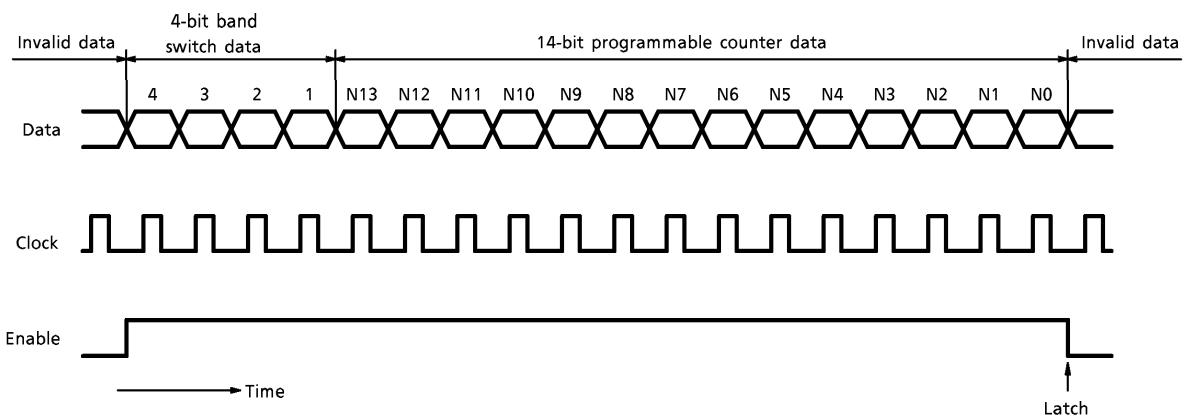

Fig.3 Normal data format (18-bit transmission)

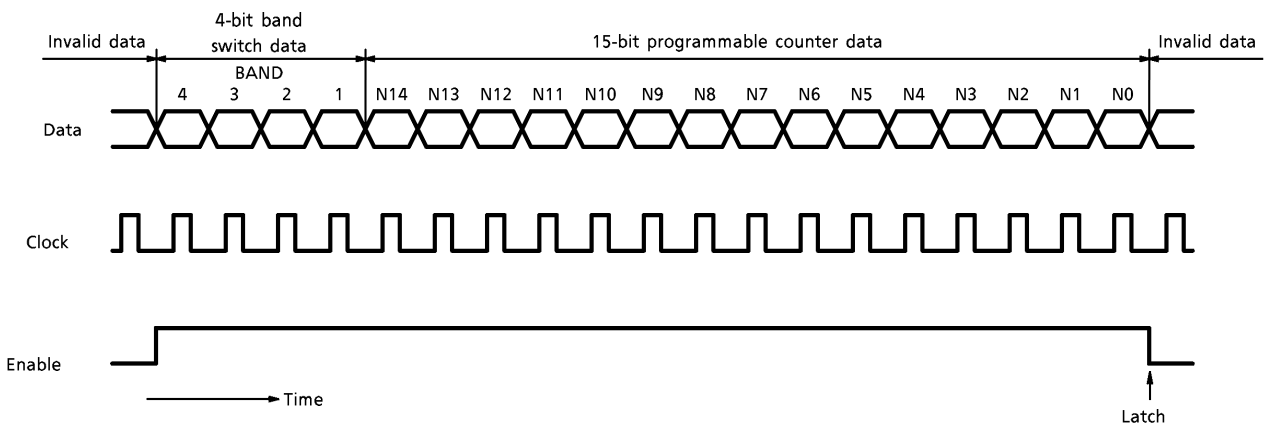

Fig.4 Normal data format (19-bit transmission)

a) 18-bit DATA TRANSMISSION :

During a high level of the enable signal, the data is clocked into the register on the falling edge of the clock.

Data are latched under the condition that the number of clocks while the enable signal is high is 18bits (the number of clock rising edges is 18).

Data are latched on the falling edge of the enable signal.

At 18-bit data transfer, N14 of the program divider is always automatically set to 『 0 』 ; the phase comparator reference frequency divider ratio is set to 1/256.

Please refer the description (Fig1. 3-wire bus data timing chart) on page 11.

b) 19-bit DATA TRANSMISSION :

During a high level of the enable signal, the data is clocked into register on the falling edge on the clock.

Data are latched under the condition that the number of clocks while the enable signal is high is 19bits (the number of clock rising edges is 19).

Data are latched on the falling edge of the enable signal.

At 19-bit data transfer, depending on the BUS-SW, the phase comparator reference frequency divider ratio is set to either 1/320 or 1/512.

Please refer the description (Fig1. 3-wire bus data timing chart) on page 11.

(2) TEST MODE

In the test mode, the settings can be changed and the function can be checked. Change from the normal mode to the test mode with a 27-bit or more of clocks and data transmission during a high level of the enable signal.

The data are latched at the 27th falling edge of the clock signal, validating the previous 27-bit data. The latch timing is the same as normal data.

The 4-bit bandswitch data and the programmable divider data are latched at the 20th bit rising edge of the clock signal, and the data is updated.

The test data are latched at the 27th bit falling edge of the clock signal, and the data is updated.

When the mode is changed from test to normal, RSa changes depending on the data bit length (18 or 19 bits, automatic discrimination). The data set in RSb in test mode are retained (see the table below).

REFERENCE FREQUENCY DIVIDER RATIO SETTING TEST MODE	DATA TRANSMISSION LENGTH	SET REFERENCE FREQUENCY DIVIDER RATIO
1 / 256	18-bit	1 / 256
	19-bit	1 / 512
1 / 320	18-bit	1 / 320
	19-bit	1 / 320
1 / 512	18-bit	1 / 256
	19-bit	1 / 512

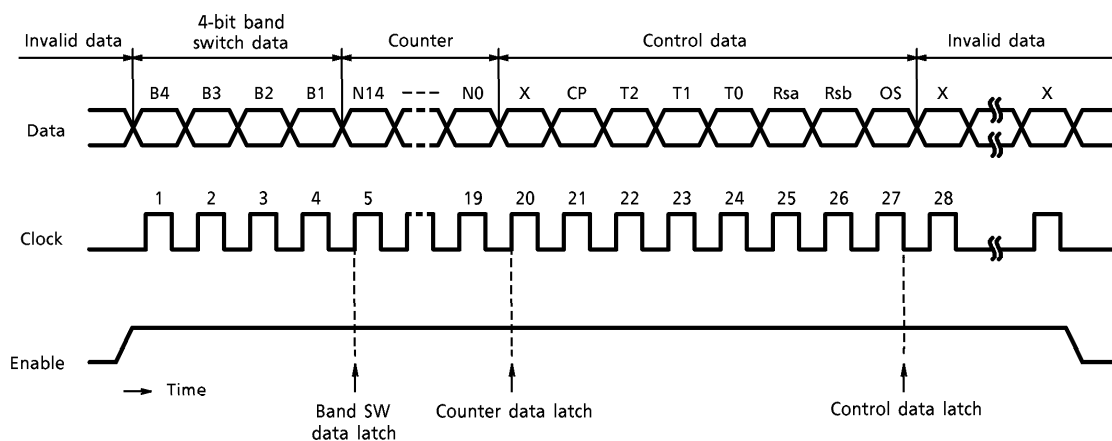

Fig.5 Test data format

(*) The data timing is the same as normal data.

TEST DATA SPECIFICATIONS

- B4~1 : Band drive data
 『 0 』 : OFF
 『 1 』 : ON
 When band drive data is 『 1 』 either Band 1 or Band 2, VHF mode.
 When band drive data is 『 0 』 both Band 1 and Band 2, UHF mode.
- N14~N0 : Programmable counter data
- CP : Charge-pump output current
 『 0 』 : ± 60 μA (Typ.)
 『 1 』 : ± 280 μA (Typ.)
- T₂, T₁, T₀ : Test bits
- T₂, T₁, T₀ : Test mode setting

CHARACTERISTIC	T ₂	T ₁	T ₀	REMARKS	
Normal Operation	0	0	×	—	
Charge-Pump	OFF	0	1	×	Charge pump is "OFF" (Check output : NF)
	Sink	1	1	0	Only charge pump Sink current is "ON" (Check output : NF)
	Source	1	1	1	Only charge pump Source current is "ON" (Check output : NF)
Reference Signal Output	1	0	0	Reference signal output : $\overline{\text{Lock}}$	
1/2 Counter Divider Output	1	0	1	1/2 counter output : $\overline{\text{Lock}}$	

× : Don't Care

(Note) When testing the counter divider output, programmable counter data input is necessary.

- R_{sa}, R_{sb} : Reference frequency divider ratio select bit.
- R_{Sa}, R_{Sb} : X'tal reference frequency divider ratio select bits.

DIVIDER RATIO	R _{Sa}	R _{Sb}
1/256	1	1
1/512	0	1
1/320	×	0

× : Don't Care

(Note) When the mode is changed from test to normal, R_{Sa} changes depending on the data bit length (18 or 19 bits, automatic discrimination). The data set in R_{Sb} in test mode are retained.

- OS : Tuning amplifier control bit
 『 0 』 : Tuning amp ON (Normal operation)
 『 1 』 : Tuning amp OFF (High impedance)
- × : Don't Care

- I²C Bus communications control

The TA1303BFN conforms to standard I²C bus format.

The I²C bus mode enables two-way bus communications with the WRITE mode, which receives data, and READ mode, which status data.

WRITE and READ modes are set using the last bit (R/W bit) of the address byte.

If the last address bit is set to [0], WRITE mode is set ; if set to [1], READ mode is set.

Addresses can be set using the hardware bits. 4 programmable addresses can be programmed.

With this setting, multiple frequency synthesizers can be used in the same I²C bus line.

The address for the hardware bit setting can be selected by applying voltage to the address setting pin (ADR : Pin 3).

An address is selected according to the set bits.

When the correct address byte is received, during acknowledgment, serial data (SDA) line is "Low".

If WRITE mode is set at this time, when the data byte is programmed, the serial data (SDA) line is "Low" during the next acknowledgment. Please refer the description (Fig2. I²C bus data timing chart) on page 11.

(1) WRITE mode (setting command)

When WRITE mode is segment, byte 1 segment the address data ; bytes 2 and 3 segment the frequency data ; byte 4 segment the divider ratio setting and function setting data ; and byte 5 segment the output port data.

Data are latched and transferred at the end of, byte 3, byte 4, and byte 5.

Bytes 2 and 3 are latched and transferred is done with a two byte set (byte 2 + byte 3).

Once a correct address is received and acknowledged, the data type is determined according to [0] or [1] set in the first bit of the next byte. That is, if the first bit is [0], the data are frequency data ; if [1], function setting or output port data.

Until the I²C bus STOP CONDITION is detected, the additional data can be input without transmitting the address again. (EX : Frequency sweep is possible with additional frequency data.)

If data transmission is aborted, data programmed before the abort are valid.

Byte 1 can set the hardware bit with address data.

The hardware bit is set with voltage applied to the address setting pin (ADR : Pin 3).

Bytes 2 and 3 are stored in the 15-bit shift register with counter data for the frequency setting, and control the 15-bit programmable counter ratio.

The Lock frequency can be calculated in the following formula :

$$f_{osc} = f_r \times 4 \times N$$

f_{osc} : Program frequency

f_r : Phase comparator reference frequency (Step frequency)

N : Counter total ratio

f_r is calculated using the crystal oscillator frequency and the reference frequency divider ratio set in byte 4 (control byte). ($f_r = X'$ tal oscillator frequency / reference frequency divider ratio)

The reference frequency divider ratio can be set to, 1/256, 1/512, and 1/320. When using a 4MHz crystal oscillator, $f_r = 15.625$ kHz, 7.8125 kHz, and 12.5 kHz. The step frequency are 62.5 kHz, 31.25 kHz, and 50 kHz.

Byte 4 is a control byte used to set functions. Bit 2 (CP) controls the output current of the charge-pump circuit. When bit 2 is set to 『 0 』, the output current is set to $\pm 60 \mu A$; when set to 『 1 』, $\pm 280 \mu A$.

Bit 3 (T_2), bit 4 (T_1) and bit 5 (T_0) are used to set the test mode. They are used to set the charge-pump test, phase comparator reference signal output, and counter divider 1/2 output.

Please refer the description (Table. 3) on page 21.

Bit 6 (Rsa) and bit 7 (Rsb) are used to set the X'tal reference frequency divider ratios.

Please refer the description (Table. 4) on page 21.

Bit 8 (OS) is used to set the charge-pump drive amplifier output setting. When bit 8 is set to 『 0 』, the output is ON (Normal use); when set to 『 1 』 the output is OFF (High impedance).

Byte 5 is used to set and control the output port (Bands 1~4). Select 『 0 』 for OFF, and 『 1 』 for ON. Please refer the description (Table. 5) on page 21.

When band switch data is 『 1 』 either Band 1 or Band 2, VHF mode.

When band switch data is 『 0 』 both Band 1 and Band 2, UHF mode.

Two output ports can be operation turned on, but be sure to keep the total output current under 50 mA.

(2) READ mode (status request)

When READ mode is set, power-on reset operation status, phase comparator lock detector output status, and 5-level A/D converter pin input voltage status are output to the master device.

Bit 1 (POR) indicates the power-on reset operation status. When the power supply of V_{CC2} stops, bit 1 is set to 『 1 』. The conditions for reset to 『 0 』 voltage supplied to V_{CC2} is 3 V or higher, transmission is requested in READ mode, and the status is output. (When V_{CC2} is turned on, bit 1 is also set to 『 1 』)

Bit 2 (FL) indicates the phase comparator lock status. When locked, 『 1 』 is output; when unlocked, 『 0 』 is output.

Bits 6, 7, and 8 (A_2 , A_1 , A_0) indicate the 5-level A/D converter status. The voltage applied to the A/D converter input pin (pin 29) is output through a 5-level resolution.

Please refer the description (Table. 6) on page 21.

(EX : The AFT output voltage data can be given to the master device.)

DATA FORMAT

a) WRITE MODE

BYTE		MSB							LSB	
1	Address Byte	1	1	0	0	0	MA1	MA0	R/W = 0	ACK
2	Divider Byte①	0	N14	N13	N12	N11	N10	N9	N8	ACK
3	Divider Byte②	N7	N6	N5	N4	N3	N2	N1	N0	ACKⓁ
4	Control Byte	1	CP	T2	T1	T0	RSa	RSb	OS	ACKⓁ
5	Band SW Byte	x	x	x	x	B4	B3	B2	B1	ACKⓁ

x : DON'T Care
 ACK : Acknowledged
 Ⓛ : Latch and transfer timing

b) READ MODE

BYTE		MSB							LSB	
1	Address Byte	1	1	0	0	0	MA1	MA0	R/W = 1	ACK
2	Status Byte	POR	FL	1	1	1	A2	A1	A0	—

x : DON'T Care
 ACK : Acknowledged

DATE SPECIFICATIONS

- MA1, MA0 : Programmable hardware address bits

ADDRESS PIN APPLIED VOLTAGE	MA1	MA0
0~0.1 × V _{CC2}	0	0
OPEN or 0.2 × V _{CC2} ~0.3 × V _{CC2}	0	1
0.4 × V _{CC2} ~0.6 × V _{CC2}	1	0
0.9 × V _{CC2} ~V _{CC2}	1	1

- N14~N0 : Programmable counter data
- CP : Charge-pump output current setting
 『 0 』 : ±60 μA (Typ.)
 『 1 』 : ±280 μA (Typ.)

Table. 3

• T₂, T₁, T₀ : Test mode setting

CHARACTERISTIC	T ₂	T ₁	T ₀	REMARKS	
Normal Operation	0	0	x	—	
Charge-Pump	OFF	0	1	x	Charge-pump is "OFF" (Check output : NF)
	Sink	1	1	0	Only charge-pump Sink current is "ON" (Check output : NF)
	Source	1	1	1	Only charge-pump Source current is "ON" (Check output : NF)
Reference Signal Output	1	0	0	Reference signal output : ADC	
1/2 Counter Divider Output	1	0	1	1/2 counter divider output : ADC	

x : DON'T Care

(Note) When testing the counter divider output, programmable counter data input is necessary.

Table. 4

• RSa, RSb : X'tal reference frequency divider ratio select bits.

RSa	RSb	DIVIDER RATIO
1	1	1 / 256
0	1	1 / 512
x	0	1 / 320

x : DON'T Care

- OS : Tuning amplifier control setting.
 [0] : Tuning amplifier ON (Normal operation)
 [1] : Tuning amplifier OFF (High impedance)

Table. 5

- B4~B1 : BAND switch data
 [0] : OFF When band drive data is [1] either Band1 or Band2, VHF mode.
 [1] : ON When band drive data is [0] both Band1 and Band2, UHF mode.
- POR : Power-on reset flag
 [0] : Normal operation
 [1] : Reset operation
- FL : Lock detect flag
 [0] : Unlocked
 [1] : Locked
- A₂, A₁, A₀ : 5-level A/D converter status.

Table. 6

ADC PIN APPLIED VOLTAGE	A ₂	A ₁	A ₀
0.60 × V _{CC2} ~V _{CC2}	1	0	0
0.45 × V _{CC2} ~0.60 × V _{CC2}	0	1	1
0.30 × V _{CC2} ~0.45 × V _{CC2}	0	1	0
0.15 × V _{CC2} ~0.30 × V _{CC2}	0	0	1
0~0.15 × V _{CC2}	0	0	0

(*) Accuracy is ± 0.03 × V_{CC2}

I²C BUS CONTROL SUMMARY

The bus control format for TA1303BFN conforms to the Philips I²C bus control format.

Data transmission format

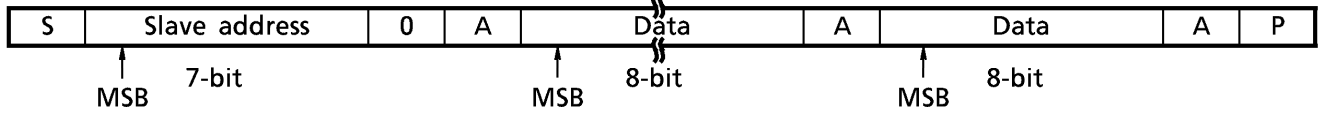

S : Start condition
 P : Stop condition
 A : Acknowledge

(1) Start/stop conditions

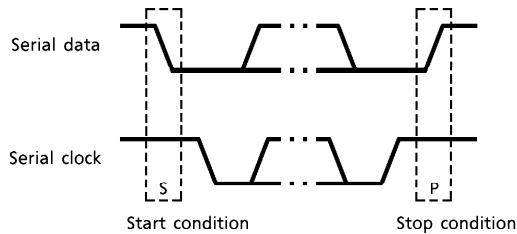

(2) Bit transfer

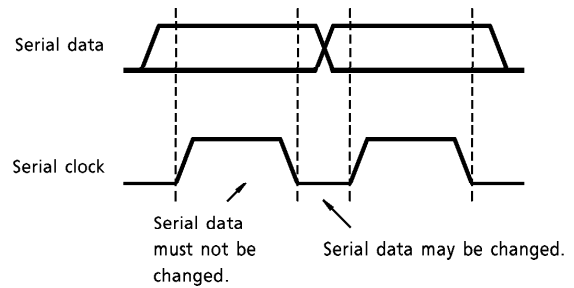

(3) Acknowledge

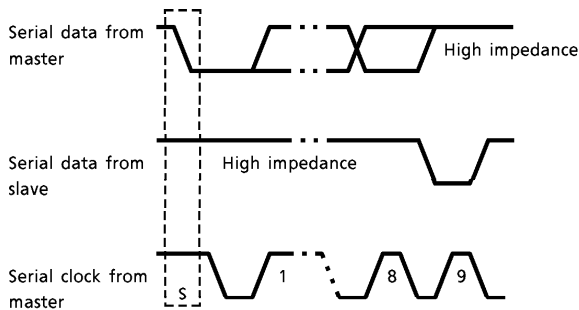

(4) Slave addresses

A ₆	A ₅	A ₄	A ₃	A ₂	A ₁	A ₀	R/ \overline{W}
1	1	0	0	0	*	*	0

Purchase of TOSHIBA I²C components conveys a license under the Philips I²C Patent Tights to use these components in an I²C system, provided that the system conforms to the I²C Standard Specification as defined by Philips.

TEST CIRCUIT 1
DC characteristics

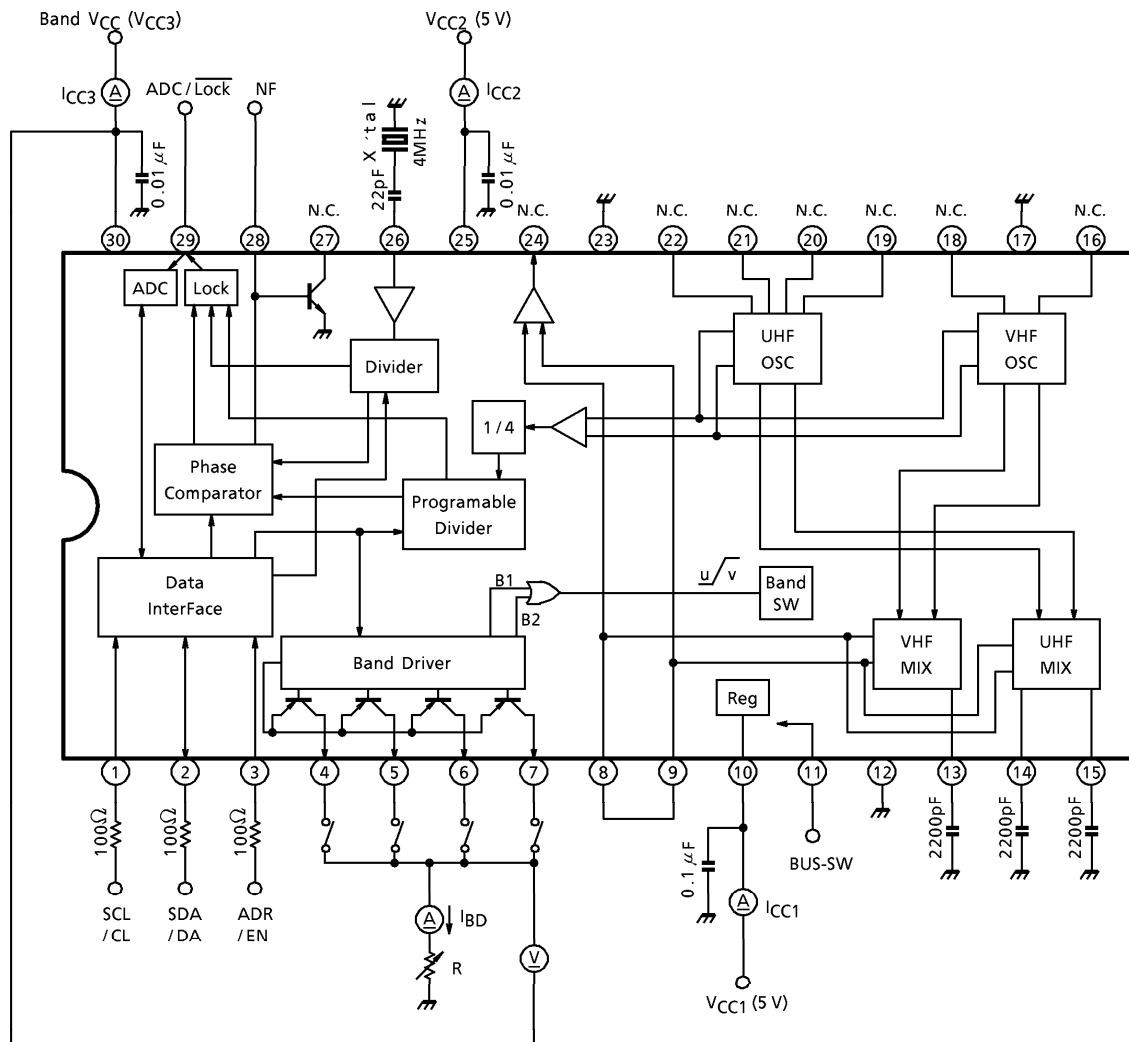

TEST CIRCUIT 2
X'tal external input measurement

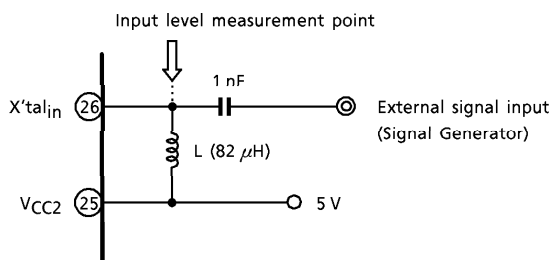

[REFERENCE DATA]

X'tal External Input Level

If it uses not only "TEST CIRCUIT 2" but "Fig.6", please refers to "Graph 1".

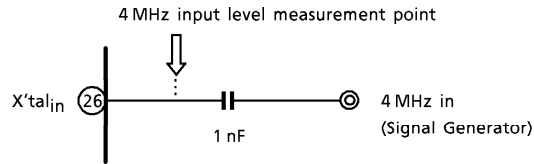
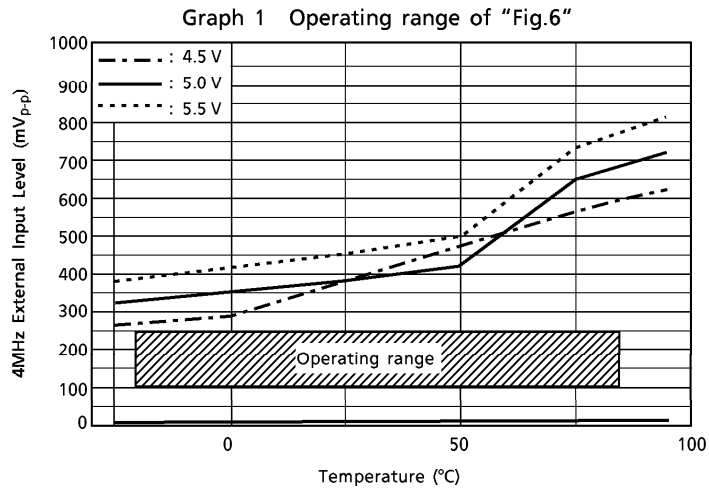

Fig.6 X'tal External Input Reference Application



HANDLING PRECAUTIONS

1. The device should not be inserted into or removed from the test jig while the voltage is being applied: otherwise the device may be degraded or break down.

Do not abruptly increase or decrease the power supply to the device either. (See Figure 1.)

Overshoot or chattering of the power supply may cause the IC to be degraded.

To avoid this filters should be incorporated on the power supply line.

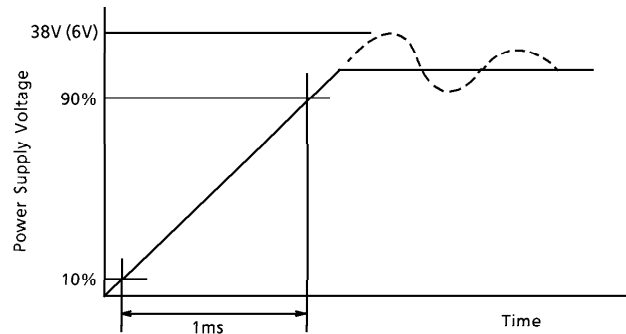

Figure 1

2. The peripheral circuits described in this datasheet are given only as system examples for evaluating the device's performance. Toshiba intend neither to recommend the configuration or related values of the peripheral circuits nor to manufacture such application systems in large quantities.

Please note that high-frequency characteristics of the device may vary depending on the external components, mounting method and other factors relating to the application design. Therefore, the characteristics of application circuits must be evaluated at the responsibility of the users incorporating the device into their design.

Toshiba only guarantee the quality and characteristics of the device as described in this datasheet and do not assume any responsibility for the customers application design.

3. In order to better understand the quality and reliability of Toshiba semiconductor products and to incorporate them into design in an appropriate manner, please refer to the latest Semiconductor Reliability Handbook (Integrated Circuits) published by Toshiba Semiconductor Company.

The handbook can also be viewed online at

<http://doc.semicon.toshiba.co.jp/noseek/us/sinrai/sinraifm.htm>.

PACKAGE DIMENSIONS
SSOP30-P-300-0.65

Unit : mm

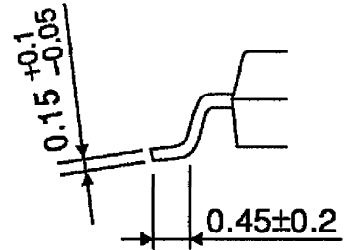
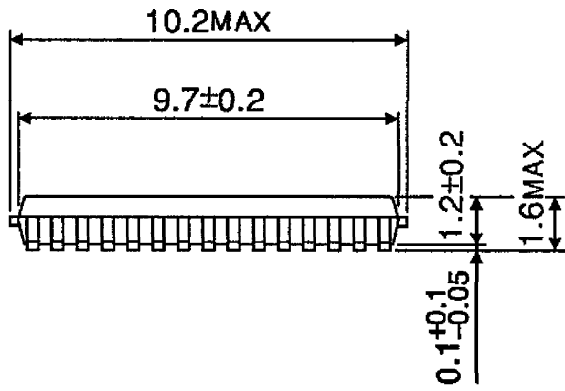
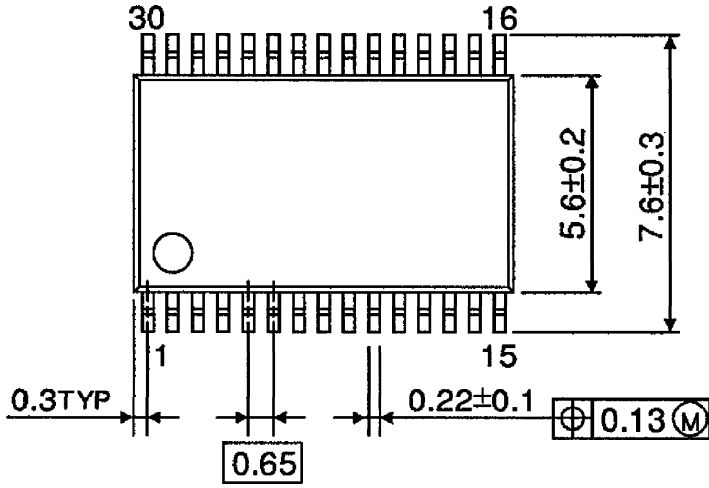

Weight : 0.17 g (Typ.)