

TC74VHCT14AF, TC74VHCT14AFN, TC74VHCT14AFT

HEX SCHMITT INVERTER

The TC74VHCT14A is an advanced high speed CMOS SCHMITT INVERTER fabricated with silicon gate C²MOS technology.

It achieves the high speed operation similar to equivalent Bipolar Schottky TTL while maintaining the CMOS low power dissipation.

Pin configuration and function are the same as the TC74VHC04 but the inputs have hysteresis and with its schmitt trigger function, the TC74VHC14 can be used as a line receivers which will receive slow input signals.

The input voltage are compatible with TTL output voltage.

This device may be used as a level converter for interfacing 3.3V to 5V system.

Input protection and output circuit ensure that 0 to 5.5V can be applied to the input and output*1 pins without regard to the supply voltage. These structure prevents device destruction due to mismatched supply and input/output voltages such as battery back up, hot board insertion, etc.

*1: V_{CC} = 0V

FEATURES :

- High Speed..... t_{pd} = 5.0ns (typ.) at V_{CC} = 5V
- Low Power Dissipation..... I_{CC} = 2μA(Max.) at Ta = 25°C
- Compatible with TTL inputs V_{IL} = 0.8V (Max.)
V_{IH} = 2.0V (Min.)
- Power Down Protection is provided on all inputs and outputs.
- Balanced Propagation Delays..... t_{pLH} ≈ t_{pHL}
- Low Noise V_{OLP} = 0.8V (Max.)
- Pin and Function Compatible with the 74 series (74AC/HC /F/ALS/LS etc.) 14 type.

(Note) The JEDEC SOP (FN) is not available in Japan.

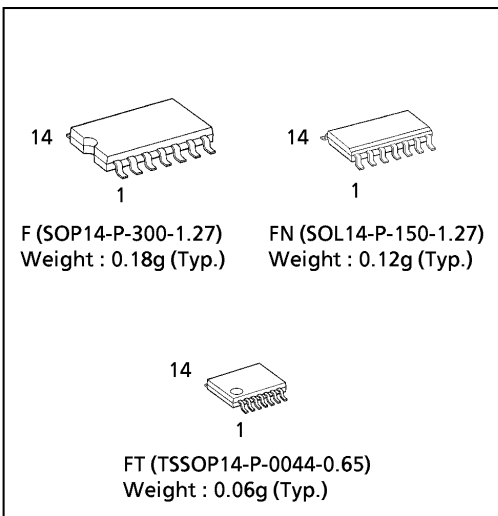

PIN ASSIGNMENT

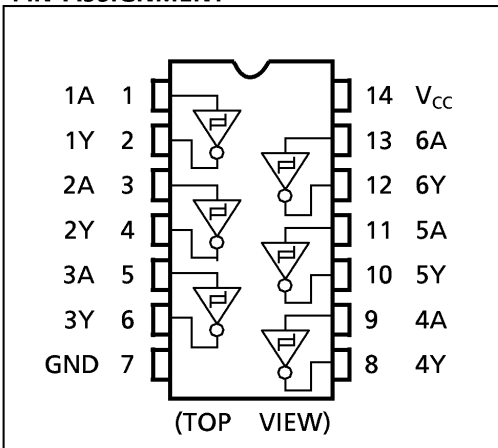

TRUTH TABLE

A	Y
L	H
H	L

SYSTEM DIAGRAM, WAVEFORM

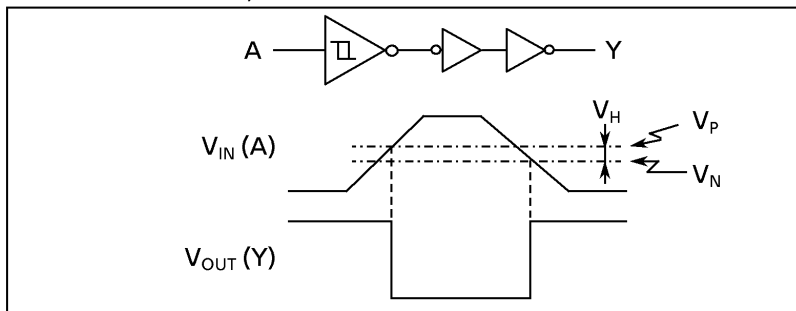

IEC LOGIC SYMBOL

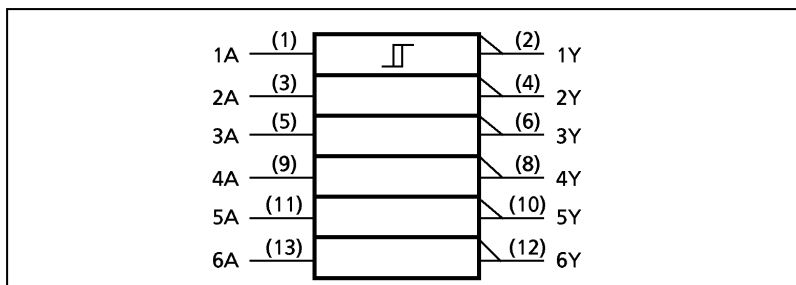

980910EBA2

● TOSHIBA is continually working to improve the quality and the reliability of its products. Nevertheless, semiconductor devices in general can malfunction or fail due to their inherent electrical sensitivity and vulnerability to physical stress. It is the responsibility of the buyer, when utilizing TOSHIBA products, to observe standards of safety, and to avoid situations in which a malfunction or failure of a TOSHIBA product could cause loss of human life, bodily injury or damage to property. In developing your designs, please ensure that TOSHIBA products are used within specified operating ranges as set forth in the most recent products specifications. Also, please keep in mind the precautions and conditions set forth in the TOSHIBA Semiconductor Reliability Handbook.

ABSOLUTE MAXIMUM RATINGS

PARAMETER	SYMBOL	VALUE	UNIT
Supply Voltage Range	V_{CC}	-0.5~7.0	V
DC Input Voltage	V_{IN}	-0.5~7.0	V
DC Output Voltage	V_{OUT}	-0.5~7.0 (Note 1)	V
		-0.5~ $V_{CC} + 0.5$ (Note 2)	
Input Diode Current	I_{IK}	-20	mA
Output Diode Current	I_{OK}	±20 (Note 3)	mA
DC Output Current	I_{OUT}	±25	mA
DC Vcc/Ground Current	I_{CC}	±50	mA
Power Dissipation	P_D	180	mW
Storage Temperature	T_{stg}	-65~150	°C

(Note 1) $V_{CC} = 0V$

(Note 2) High or Low State. I_{OUT} absolute maximum rating must be observed.

(Note 3) $V_{OUT} < GND$, $V_{OUT} > V_{CC}$

RECOMMENDED OPERATING CONDITIONS

PARAMETER	SYMBOL	VALUE	UNIT
Supply Voltage	V_{CC}	4.5~5.5	V
Input Voltage	V_{IN}	0~5.5	V
Output Voltage	V_{OUT}	0~5.5 (Note 4)	V
		0~ V_{CC} (Note 5)	
Operating Temperature	T_{opr}	-40~85	°C
Input Rise and Fall Time	dt / dV	0~20	ns / V

(Note 4) $V_{CC} = 0V$

(Note 5) High or Low State

980910EBA2'

- The products described in this document are subject to the foreign exchange and foreign trade laws.
- The information contained herein is presented only as a guide for the applications of our products. No responsibility is assumed by TOSHIBA CORPORATION for any infringements of intellectual property or other rights of the third parties which may result from its use. No license is granted by implication or otherwise under any intellectual property or other rights of TOSHIBA CORPORATION or others.
- The information contained herein is subject to change without notice.

DC ELECTRICAL CHARACTERISTICS

PARAMETER	SYMBOL	TEST CONDITION	V _{CC} (V)	Ta = 25°C			Ta = -40~85°C		UNIT
				MIN.	TYP.	MAX.	MIN.	MAX.	
Positive Threshold Voltage	V _P		4.5	—	—	1.90	—	1.90	V
			5.5	—	—	2.10	—	2.10	
Negative Threshold Voltage	V _N		4.5	0.50	—	—	0.50	—	V
			5.5	0.60	—	—	0.60	—	
Hysteresis Voltage	V _H		4.5	0.40	—	1.40	0.40	1.40	V
			5.5	0.40	—	1.50	0.40	1.50	
High - Level Output Voltage	V _{OH}	V _{IN} = V _{IL}	I _{OH} = -50μA	4.5	4.4	4.5	—	4.4	V
			I _{OH} = -8mA	4.5	3.94	—	—	3.80	
Low - Level Output Voltage	V _{OL}	V _{IN} = V _{IH}	I _{OL} = 50μA	4.5	—	0.0	0.1	—	V
			I _{OL} = 8mA	4.5	—	—	0.36	—	
Input Leakage Current	I _{IN}	V _{IN} = 5.5V or GND	0~5.5	—	—	±0.1	—	±1.0	μA
Quiescent Supply Current	I _{CC}	V _{IN} = V _{CC} or GND	5.5	—	—	2.0	—	20.0	mA
	I _{CC(T)}	PER INPUT : V _{IN} = 3.4V OTHER INPUT : V _{CC} or GND	5.5	—	—	1.35	—	1.50	
Output Leakage Current	I _{OPD}	V _{OUT} = 5.5V	0	—	—	0.5	—	5.0	μA

AC ELECTRICAL CHARACTERISTICS (Input t_r = t_f = 3ns)

PARAMETER	SYMBOL	TEST CONDITION	Ta = 25°C			Ta = -40~85°C		UNIT		
			V _{CC} (V)	CL (pF)	MIN.	TYP.	MAX.		MIN.	MAX.
Propagation Delay Time	t _{pLH}	5.0 ± 0.5	5.0 ± 0.5	15	—	5.0	7.6	1.0	9.0	ns
	t _{pHL}			50	—	6.5	9.6	1.0	11.0	
Input Capacitance	C _{IN}				—	4	10	—	10	pF
Power Dissipation Capacitance	C _{PD}	(Note 6)			—	18	—	—	—	

(Note 6) C_{PD} is defined as the value of the internal equivalent capacitance which is calculated from the operating current consumption without load.

Average operating current can be obtained by the equation :

$$I_{CC(opr.)} = C_{PD} \cdot V_{CC} \cdot f_{IN} + I_{CC} / 6 \text{ (per Gate)}$$

NOISE CHARACTERISTICS (Input t_r = t_f = 3ns)

PARAMETER	SYMBOL	TEST CONDITION	Ta = 25°C			UNIT
			V _{CC} (V)	TYP.	LIMIT	
Quiet Output Maximum Dynamic V _{OL}	V _{OLP}	C _L = 50pF	5.0	0.5	0.8	V
Quiet Output Minimum Dynamic V _{OL}	V _{OLV}	C _L = 50pF	5.0	-0.5	-0.8	V
Minimum High Level Dynamic Input Voltage	V _{IHD}	C _L = 50pF	5.0	—	2.0	V
Maximum Low Level Dynamic Input Voltage	V _{ILD}	C _L = 50pF	5.0	—	0.8	V

SOP 14PIN (200mil BODY) PACKAGE DIMENSIONS (SOP14-P-300-1.27)

Unit in mm

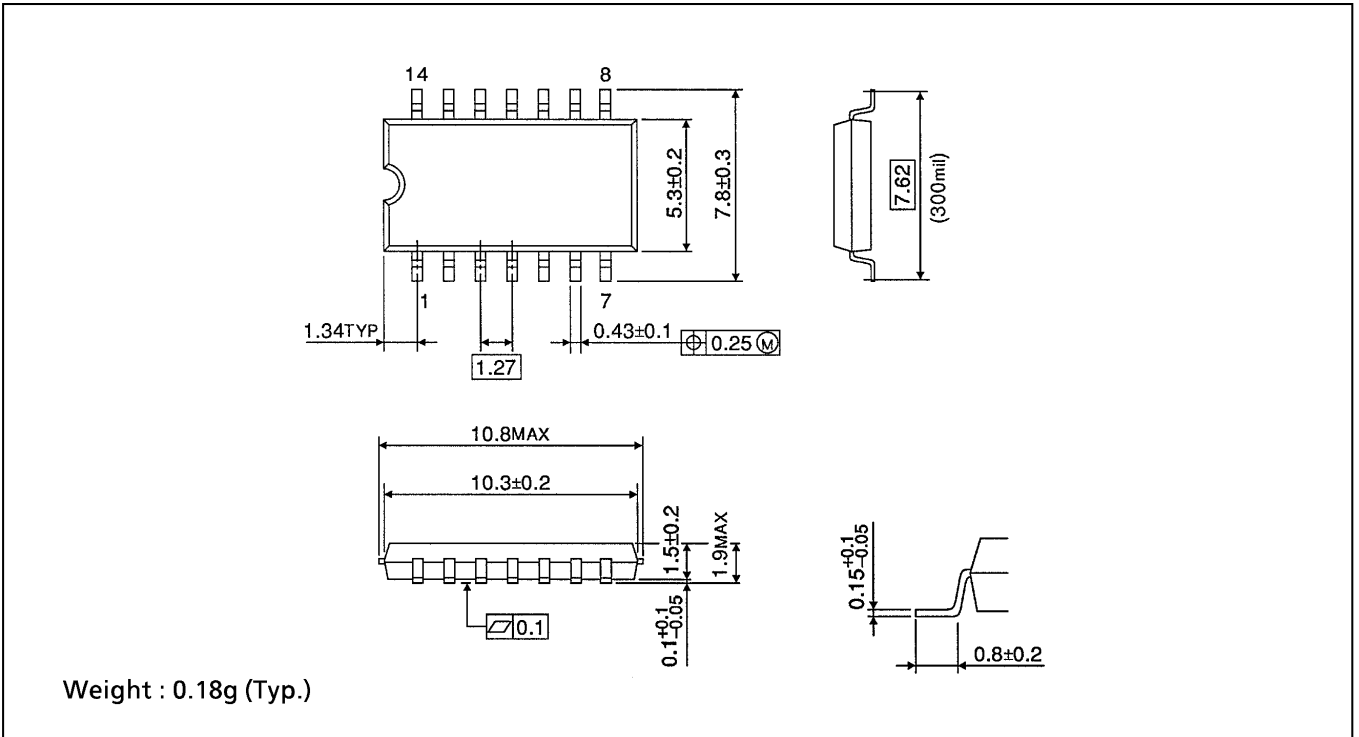

SOP 14PIN (150mil BODY) PACKAGE DIMENSIONS (SOL14-P-150-1.27)

Unit in mm

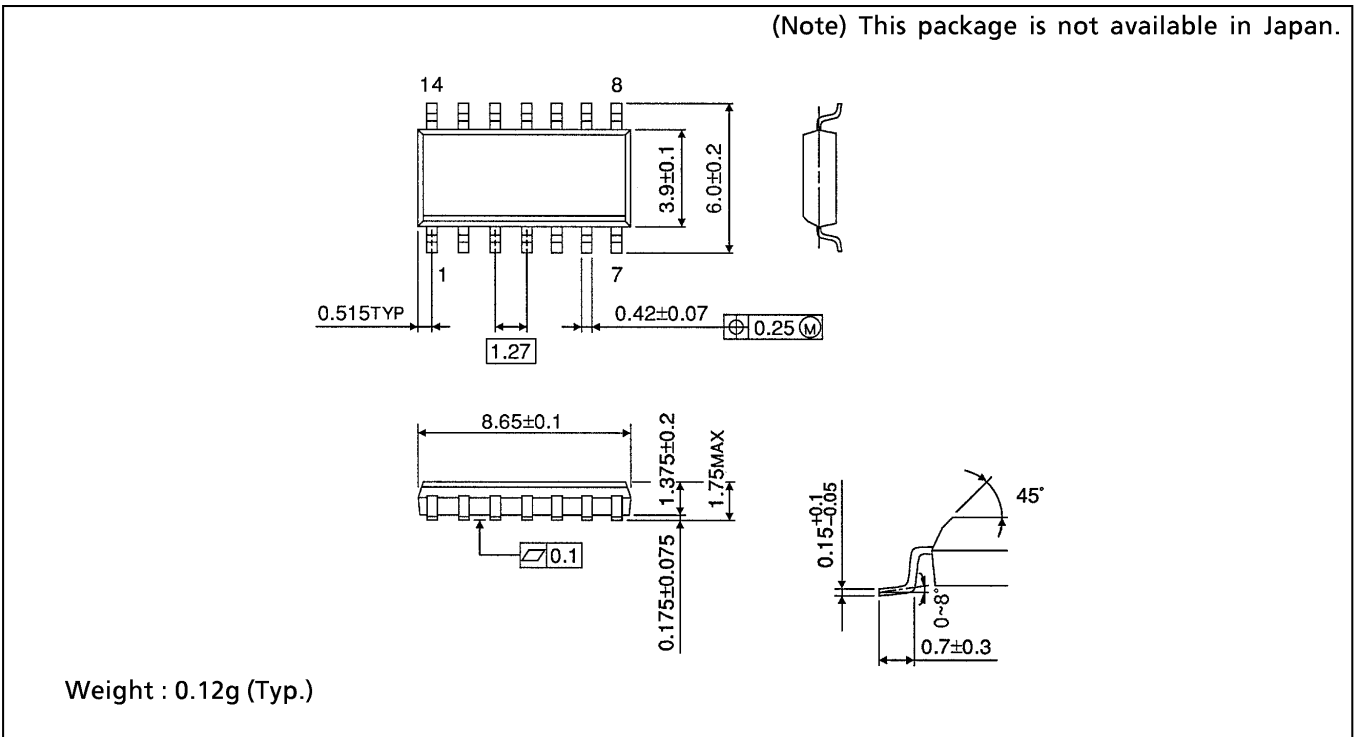

TSSOP 14PIN PACKAGE DIMENSIONS (TSSOP14-P-0044-0.65)

Unit in mm

