

MiniLED

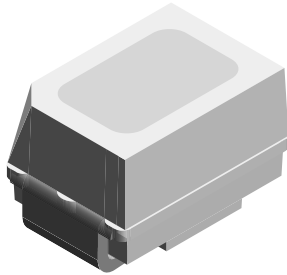

19226

FEATURES

- SMD LEDs with exceptional brightness
- Luminous intensity categorized
- Compatible with automatic placement equipment
- EIA and ICE standard package
- IR reflow soldering
- Available in 8 mm tape
- Low profile package
- Excellent for coupling to light pipes and backlighting
- Low power consumption
- Luminous intensity ratio in one packaging unit $I_{Vmax}/I_{Vmin} \leq 2.0$, optional ≤ 1.6
- Lead (Pb)-free device - RoHS compliant
- Preconditioning: acc. to JEDEC Level 3
- ESD-withstand voltage up to 1 kV according to JESD22-A114-B



DESCRIPTION

The MiniLED has been designed to meet the increasing demand for white SMD LEDs. The feature of the device is the very small package 2.2 mm x 1.3 mm x 1.4 mm. The MiniLED is an obvious solution for small-scale, high-power products that are expected to work reliably in an arduous environment. This is often the case in automotive and industrial application of course.

APPLICATIONS

- Automotive: Backlighting in dashboards and switches
- Telecommunication: Indicator and backlighting in telephone and fax
- Indicator and backlight for audio and video equipment
- Indicator and backlight in office equipment
- Flat backlight for LCDs, switches and symbols
- General use

PARTS TABLE

| PART | COLOR, LUMINOUS INTENSITY | ANGLE OF HALF INTENSITY ($\pm \varphi$) | TECHNOLOGY |
|---------------|---------------------------|---|--------------------|
| VLMW2100-GS08 | White, $I_V \geq 56$ mcd | 60° | InGaN / TAG on SiC |

ABSOLUTE MAXIMUM RATINGS¹⁾ VLMW2100

| PARAMETER | TEST CONDITION | SYMBOL | VALUE | UNIT |
|-------------------------------------|--|------------|---------------|------|
| Reverse voltage ²⁾ | | V_R | 5 | V |
| DC Forward current | $T_{amb} \leq 60$ °C | I_F | 20 | mA |
| Surge forward current | $t_p \leq 10$ μ s | I_{FSM} | 0.1 | A |
| Power dissipation | | P_V | 80 | mW |
| Junction temperature | | T_j | 100 | °C |
| Operating temperature range | | T_{amb} | - 40 to + 100 | °C |
| Storage temperature range | | T_{stg} | - 40 to + 100 | °C |
| Thermal resistance junction/ambient | mounted on PC board (pad size > 16 mm ²) | R_{thJA} | 480 | K/W |

¹⁾ $T_{amb} = 25$ °C, unless otherwise specified

²⁾ Driving the LED in reverse direction is suitable for short term application



| OPTICAL AND ELECTRICAL CHARACTERISTICS ¹⁾ WHITE VLMW2100 | | | | | | | |
|---|------------------------|----------|-----------|-----|----------|-----|------|
| PARAMETER | TEST CONDITION | PART | SYMBOL | MIN | TYP. | MAX | UNIT |
| Luminous intensity ²⁾ | $I_F = 10 \text{ mA}$ | VLMW2100 | I_V | 56 | 80 | | mcd |
| Chromaticity coordinate x acc. to CIE 1931 | $I_F = 10 \text{ mA}$ | VLMW210. | x | | 0.33 | | |
| Chromaticity coordinate y acc. to CIE 1931 | $I_F = 10 \text{ mA}$ | VLMW210. | y | | 0.33 | | |
| Angle of half intensity | $I_F = 10 \text{ mA}$ | | φ | | ± 60 | | deg |
| Forward voltage | $I_F = 10 \text{ mA}$ | | V_F | | 3.0 | 3.7 | V |
| Reverse voltage | $I_R = 10 \mu\text{A}$ | | V_R | 5 | | | V |
| Temperature coefficient of V_F | $I_F = 20 \text{ mA}$ | | TC_{VF} | | -3.6 | | mV/K |
| Temperature coefficient of I_V | $I_F = 20 \text{ mA}$ | | TC_{IV} | | -0.3 | | %/K |

¹⁾ $T_{amb} = 25 \text{ }^\circ\text{C}$, unless otherwise specified

²⁾ in one Packing Unit $I_{Vmax}/I_{Vmin} \leq 1.6$

| LUMINOUS INTENSITY CLASSIFICATION | | | |
|-----------------------------------|-----------------------|-----|-----|
| GROUP | LIGHT INTENSITY [MCD] | | |
| | OPTIONAL | MIN | MAX |
| P | 2 | 56 | 71 |
| Q | 1 | 71 | 90 |
| | 2 | 90 | 112 |
| R | 1 | 112 | 140 |
| | 2 | 140 | 180 |
| S | 1 | 180 | 224 |
| | 2 | 224 | 280 |

Note:

Luminous intensity is tested at a current pulse duration of 25 ms and an accuracy of $\pm 11 \%$.

The above type Numbers represent the order groups which include only a few brightness groups. Only one group will be shipped on each reel (there will be no mixing of two groups on each reel). In order to ensure availability, single brightness groups will not be orderable.

In a similar manner for colors where wavelength groups are measured and binned, single wavelength groups will be shipped on any one reel.

In order to ensure availability, single wavelength groups will not be orderable.

| CROSSING TABLE | |
|----------------|--------|
| VISHAY | OSRAM |
| VLMW2100 | LWM673 |

| CHROMATICITY COORDINATE CLASSIFICATION | | | | | |
|--|-------|-------|----|-------|-------|
| | X | Y | | X | Y |
| 3L | 0.266 | 0.232 | 6L | 0.310 | 0.297 |
| | 0.258 | 0.239 | | 0.307 | 0.312 |
| | 0.273 | 0.261 | | 0.330 | 0.347 |
| | 0.280 | 0.252 | | 0.330 | 0.330 |
| 3K | 0.273 | 0.227 | 6K | 0.313 | 0.284 |
| | 0.266 | 0.232 | | 0.310 | 0.297 |
| | 0.280 | 0.252 | | 0.330 | 0.330 |
| | 0.286 | 0.244 | | 0.330 | 0.310 |
| 4L | 0.280 | 0.252 | 7L | 0.330 | 0.330 |
| | 0.273 | 0.261 | | 0.330 | 0.347 |
| | 0.285 | 0.279 | | 0.347 | 0.371 |
| | 0.291 | 0.268 | | 0.345 | 0.352 |
| 4K | 0.286 | 0.244 | 7K | 0.330 | 0.310 |
| | 0.280 | 0.252 | | 0.330 | 0.330 |
| | 0.291 | 0.268 | | 0.338 | 0.342 |
| | 0.296 | 0.259 | | 0.352 | 0.344 |
| 5L | 0.291 | 0.268 | 8L | 0.345 | 0.352 |
| | 0.285 | 0.279 | | 0.347 | 0.371 |
| | 0.307 | 0.312 | | 0.367 | 0.401 |
| | 0.310 | 0.297 | | 0.364 | 0.380 |
| 5K | 0.296 | 0.259 | 8K | 0.352 | 0.344 |
| | 0.291 | 0.268 | | 0.338 | 0.342 |
| | 0.310 | 0.297 | | 0.364 | 0.380 |
| | 0.313 | 0.284 | | 0.360 | 0.357 |

Note: Chromaticity coordinate groups are tested at a current pulse duration of 25 ms and a tolerance of ± 0.01 .



TYPICAL CHARACTERISTICS

$T_{amb} = 25\text{ }^{\circ}\text{C}$, unless otherwise specified

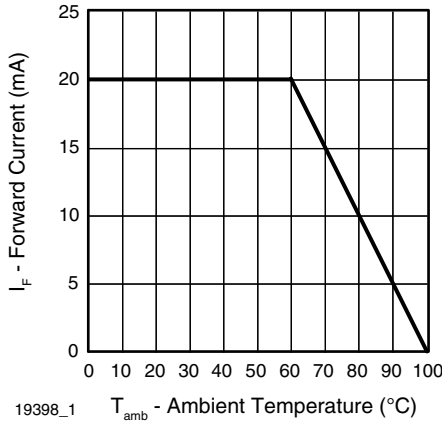

Figure 1. Forward Current vs. Ambient Temperature

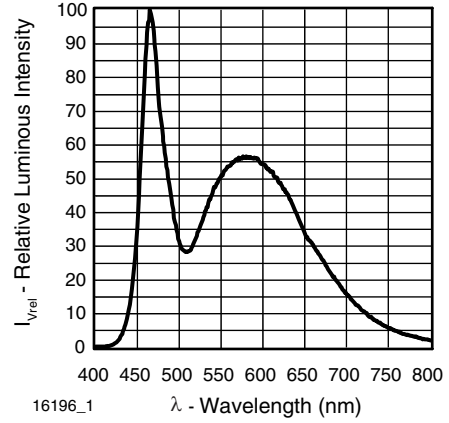

Figure 4. Relative Intensity vs. Wavelength

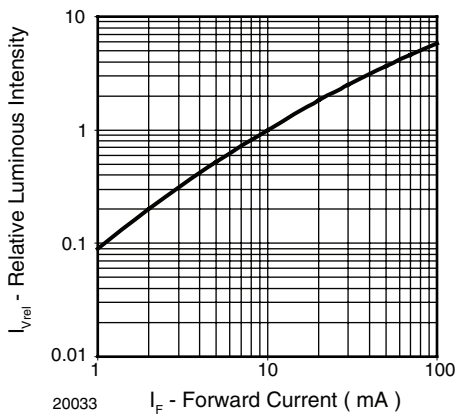

Figure 2. Relative Luminous Intensity vs. Forward Current

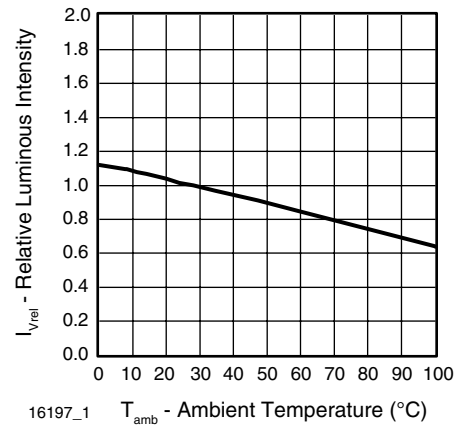

Figure 5. Rel. Luminous Intensity vs. Ambient Temperature

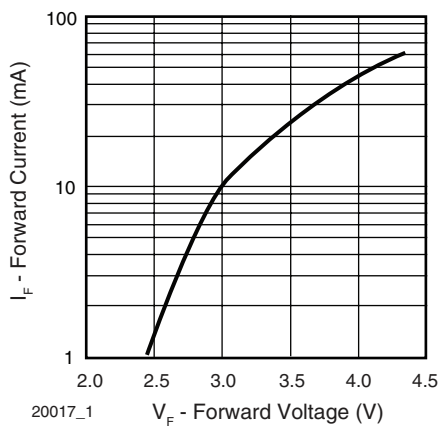

Figure 3. Forward Current vs. Forward Voltage

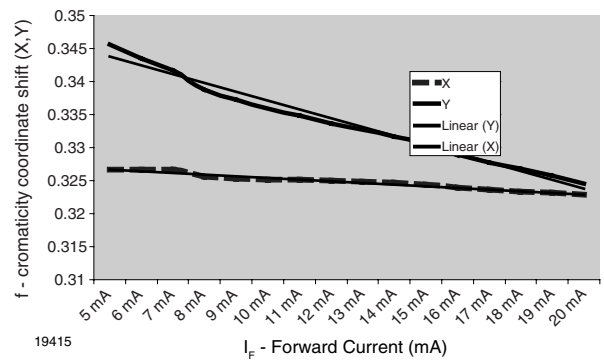

Figure 6. Chromaticity Coordinate Shift vs. Forward Current

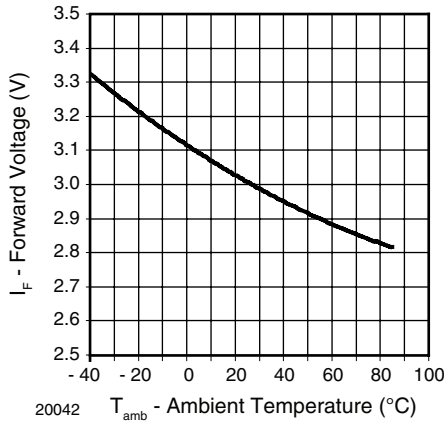
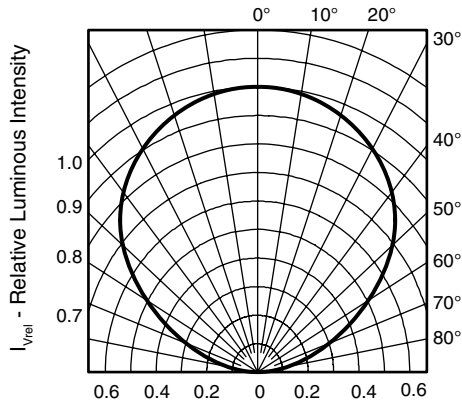
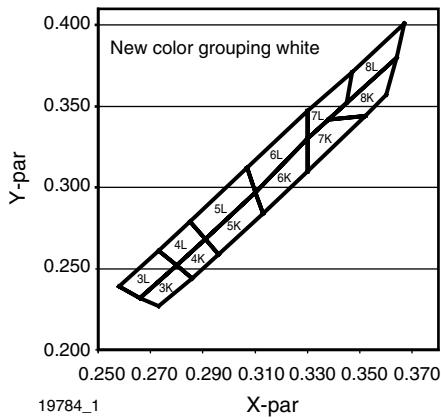

Figure 7. Forward Voltage vs. Ambient Temperature



95 10319_1

Figure 8. Rel. Luminous Intensity vs. Angular Displacement



19784_1

Figure 9. White Grouping SMD



PACKAGE DIMENSIONS

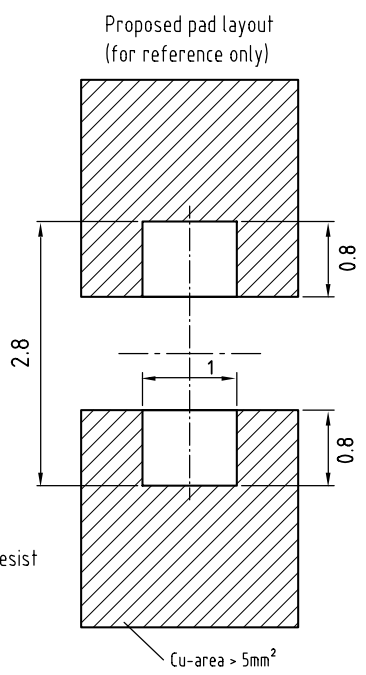
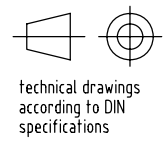
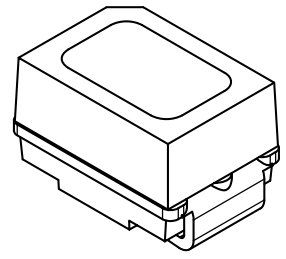
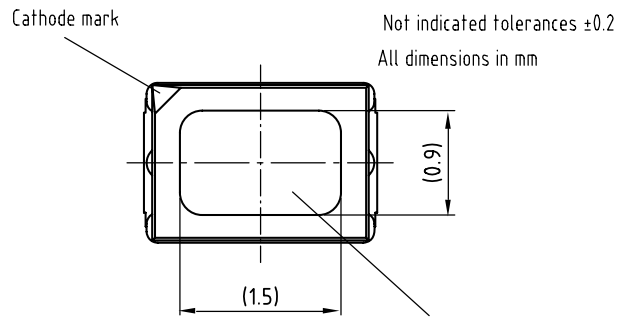
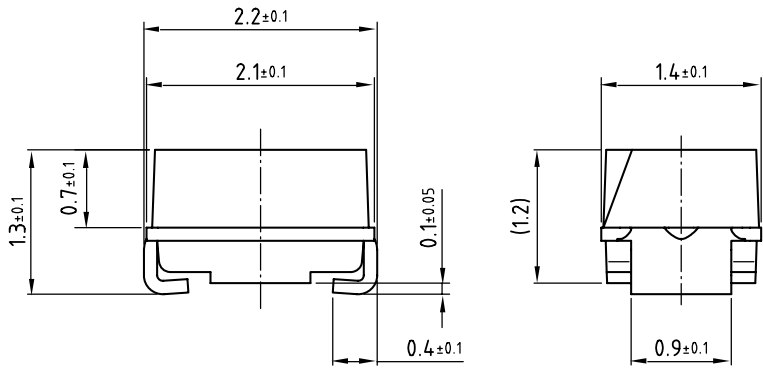

Drawing-No.: 6.541-5052.01-4
Issue: 3; 22.04.03

16892

REEL DIMENSIONS IN MM

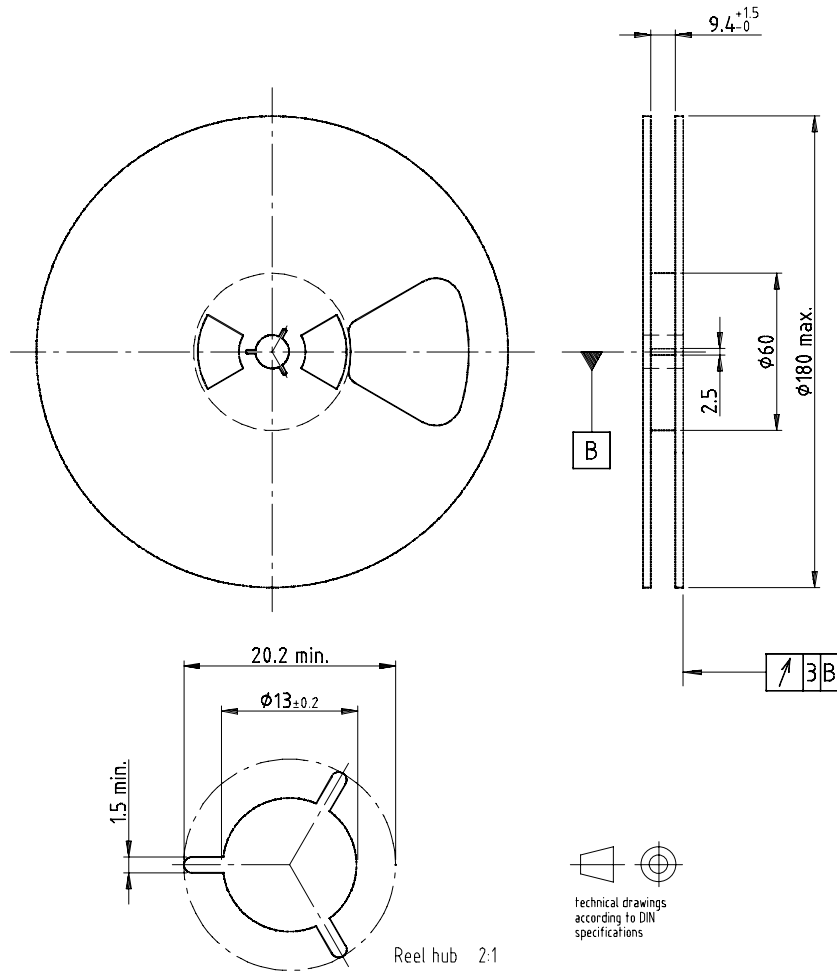

Drawing-No.: 9.800-5051.V5-4
Issue: 1; 25.07.02

16938



TAPE DIMENSIONS IN MM

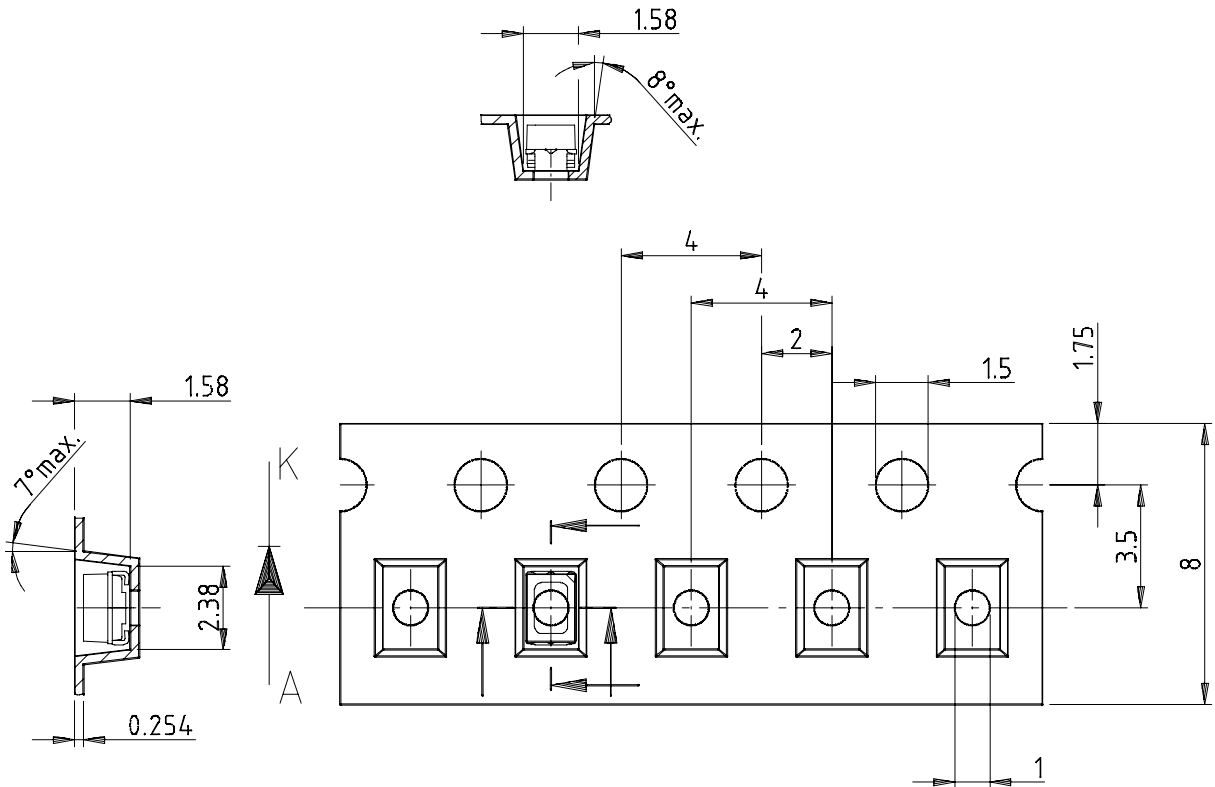

Drawing-No.: 9.700-5266.01-4
Issue: 1; 05.06.02

16939

LEADER AND TRAILER

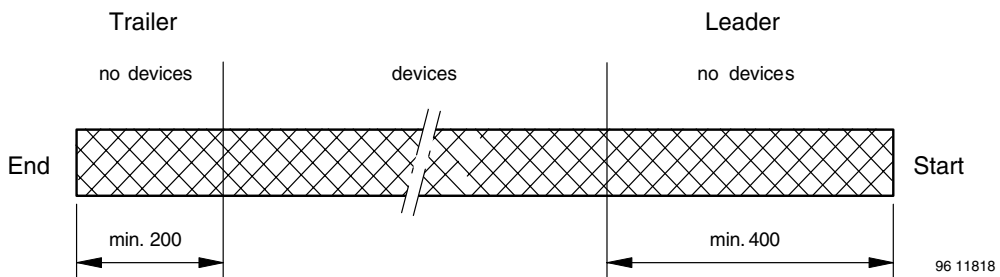

GS08 = 3000 pcs

COVER TAPE PEEL STRENGTH

According to DIN EN 60286-3

0.1 to 1.3 N

300 ± 10 mm/min

165° - 180° peel angle

LABEL

Standard bar code labels for finished goods

The standard bar code labels are product labels and used for identification of goods. The finished goods are packed in final packing area. The standard packing units are labeled with standard bar code labels before transported as finished goods to warehouses. The labels are on each packing unit and contain Vishay Semiconductor GmbH specific data.

Vishay Semiconductor GmbH standard bar code product label (finished goods)

| Plain Writing | Abbreviation | Length |
|----------------------|----------------------|--------------|
| Item-Description | – | 18 |
| Item-Number | INO | 8 |
| Selection-Code | SEL | 3 |
| LOT-/ Serial-Number | BATCH | 10 |
| Data-Code | COD | 3 (YWW) |
| Plant-Code | PTC | 2 |
| Quantity | QTY | 8 |
| Accepted by: | ACC | – |
| Packed by: | PCK | – |
| Mixed Code Indicator | MIXED CODE | – |
| Origin | xxxxxxx ⁺ | Company Logo |

| Long Bar Code Top | Type | Length |
|-------------------|------|--------|
| Item-Number | N | 8 |
| Plant-Code | N | 2 |
| Sequence-Number | X | 3 |
| Quantity | N | 8 |
| Total Length | – | 21 |

| Short Bar Code Bottom | Type | Length |
|-----------------------|------|--------|
| Selection-Code | X | 3 |
| Data-Code | N | 3 |
| Batch-Number | X | 10 |
| Filter | – | 1 |
| Total Length | – | 17 |

16942



SOLDERING PROFILE

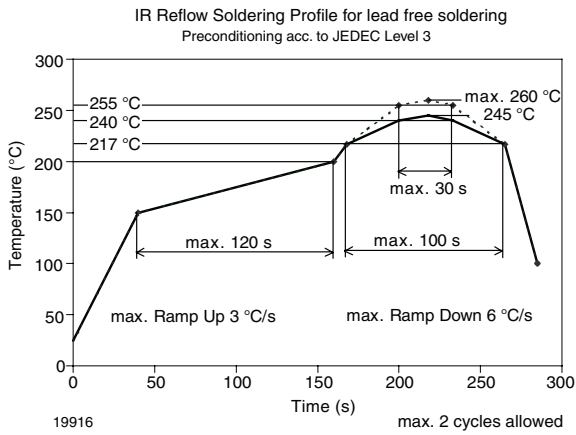

Vishay Leadfree Reflow Soldering Profile
(acc. to J-STD-020B)

BARCODE-PRODUCT-LABEL

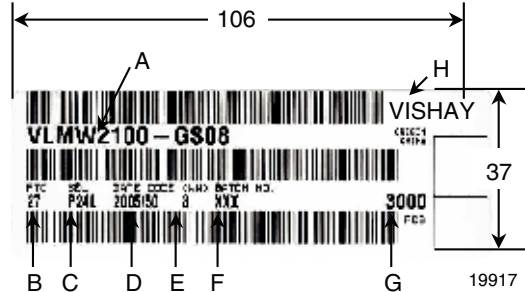

- A) Type of component
- B) Manufacturing plant
- C) SEL - Selection Code (Bin):
e.g.: P2 = Code for Luminous Intensity Group
4L = Code for Chromaticity Coordinate Group
- D) Date Code year/week
- E) Day Code (e.g. 3: Wednesday)
- F) Batch No.
- G) Total quantity
- H) Company Code

DRY PACKING

The reel is packed in an anti-humidity bag to protect the devices from absorbing moisture during transportation and storage.

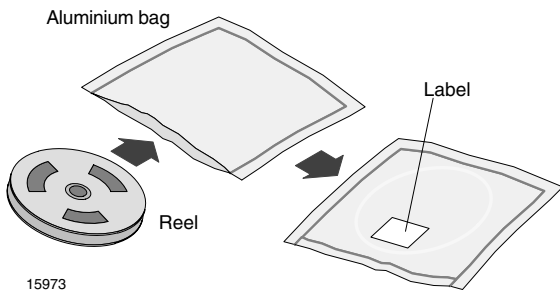

FINAL PACKING

The sealed reel is packed into a cardboard box. A secondary cardboard box is used for shipping purposes.

RECOMMENDED METHOD OF STORAGE

Dry box storage is recommended as soon as the aluminium bag has been opened to prevent moisture absorption. The following conditions should be observed, if dry boxes are not available:

- Storage temperature 10 °C to 30 °C
- Storage humidity $\leq 60\%$ RH max.

After more than 168 h under these conditions moisture content will be too high for reflow soldering.

In case of moisture absorption, the devices will recover to the former condition by drying under the following condition:

192 hours at 40 °C + 5 °C/ - 0 °C and < 5 % RH (dry air/ nitrogen) or

96 hours at 60 °C + 5 °C and < 5 % RH for all device containers or

24 hours at 100 °C + 5 °C not suitable for reel or tubes.

An EIA JEDEC Standard JESD22-A112 Level 3 label is included on all dry bags.

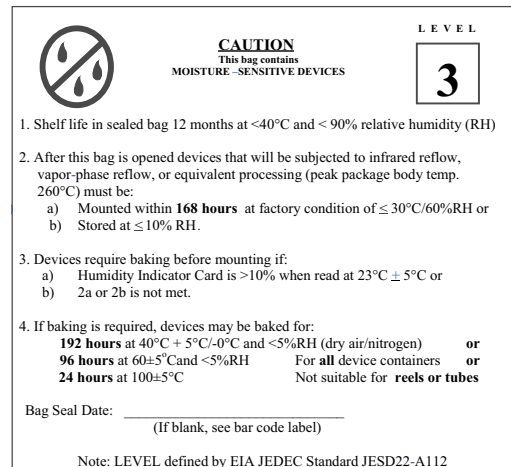

Example of JESD22-A112 Level 3 label

ESD PRECAUTION

Proper storage and handling procedures should be followed to prevent ESD damage to the devices especially when they are removed from the Antistatic Shielding Bag. Electro-Static Sensitive Devices warning labels are on the packaging.

VISHAY SEMICONDUCTORS STANDARD BAR-CODE LABELS

The Vishay Semiconductors standard bar-code labels are printed at final packing areas. The labels are on each packing unit and contain Vishay Semiconductors specific data.



Ozone Depleting Substances Policy Statement

It is the policy of Vishay Semiconductor GmbH to

1. Meet all present and future national and international statutory requirements.
2. Regularly and continuously improve the performance of our products, processes, distribution and operating systems with respect to their impact on the health and safety of our employees and the public, as well as their impact on the environment.

It is particular concern to control or eliminate releases of those substances into the atmosphere which are known as ozone depleting substances (ODSs).

The Montreal Protocol (1987) and its London Amendments (1990) intend to severely restrict the use of ODSs and forbid their use within the next ten years. Various national and international initiatives are pressing for an earlier ban on these substances.

Vishay Semiconductor GmbH has been able to use its policy of continuous improvements to eliminate the use of ODSs listed in the following documents.

1. Annex A, B and list of transitional substances of the Montreal Protocol and the London Amendments respectively
2. Class I and II ozone depleting substances in the Clean Air Act Amendments of 1990 by the Environmental Protection Agency (EPA) in the USA
3. Council Decision 88/540/EEC and 91/690/EEC Annex A, B and C (transitional substances) respectively.

Vishay Semiconductor GmbH can certify that our semiconductors are not manufactured with ozone depleting substances and do not contain such substances.

We reserve the right to make changes to improve technical design
and may do so without further notice.

Parameters can vary in different applications. All operating parameters must be validated for each customer application by the customer. Should the buyer use Vishay Semiconductors products for any unintended or unauthorized application, the buyer shall indemnify Vishay Semiconductors against all claims, costs, damages, and expenses, arising out of, directly or indirectly, any claim of personal damage, injury or death associated with such unintended or unauthorized use.

Vishay Semiconductor GmbH, P.O.B. 3535, D-74025 Heilbronn, Germany



Notice

Specifications of the products displayed herein are subject to change without notice. Vishay Intertechnology, Inc., or anyone on its behalf, assumes no responsibility or liability for any errors or inaccuracies.

Information contained herein is intended to provide a product description only. No license, express or implied, by estoppel or otherwise, to any intellectual property rights is granted by this document. Except as provided in Vishay's terms and conditions of sale for such products, Vishay assumes no liability whatsoever, and disclaims any express or implied warranty, relating to sale and/or use of Vishay products including liability or warranties relating to fitness for a particular purpose, merchantability, or infringement of any patent, copyright, or other intellectual property right.

The products shown herein are not designed for use in medical, life-saving, or life-sustaining applications. Customers using or selling these products for use in such applications do so at their own risk and agree to fully indemnify Vishay for any damages resulting from such improper use or sale.