

# AN8013SH

## Single-channel step-up or step-down DC-DC converter control IC

### ■ Overview

The AN8013SH is a single-channel PWM DC-DC converter control IC. This IC implements DC-DC converters that provide a single arbitrary output voltage that is either a stepped-up or stepped-down level. It features a wide operating supply voltage range, low power, and a built-in overcurrent protection circuit to protect the switching transistor from damage or destruction. The AN8013SH is provided in a 0.5 mm pitch 10-pin surface mounting package and is optimal for use in miniature high-efficiency portable power supplies.

### ■ Features

- Wide operating supply voltage range (3.6 V to 34 V)
- Small consumption current (2.4 mA typical)
- Supports control over a wide output frequency range: 20 kHz to 500 kHz.
- Built-in pulse-by-pulse overcurrent protection circuit (Detection voltage:  $V_{CC} - 100$  mV)
- Built-in timer latch short-circuit protection circuit (charge current 1.3  $\mu$ A typical)
- Incorporating the under-voltage lock-out (U.V.L.O.) circuit
- Built-in reference voltage circuit (Error amplifier reference input: 0.75 V (allowance:  $\pm 4\%$ ))
- Output block is open-collector (darlington) type.
- High absolute maximum rating of output current (100 mA)
- Duty ratio with small sample-to-sample variations ( $55\% \pm 5\%$ ).
- Adopts a 0.5-mm lead pitch 10-pin small outline package

### ■ Applications

- Switching mode power supply units (in portable equipment and other applications)

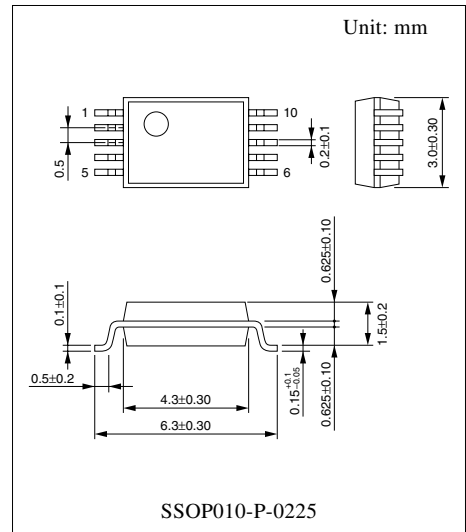

### ■ Pin Descriptions

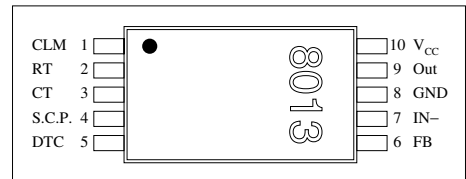

### ■ Block Diagram

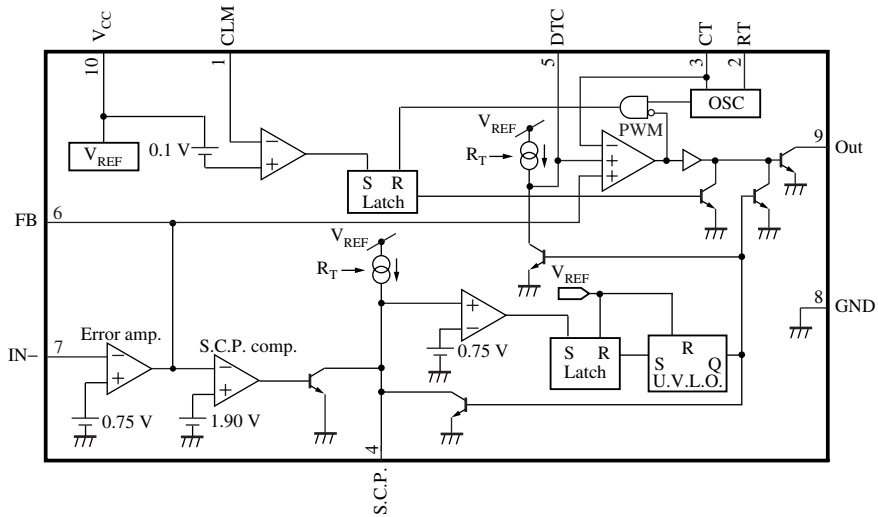

### ■ Absolute Maximum Ratings at $T_a = 25^\circ\text{C}$

Parameter	Symbol	Rating	Unit
Supply voltage	$V_{CC}$	35	V
CLM pin allowable application voltage	$V_{CLM}$	35	V
Error amplifier allowable input voltage	$V_{IN-}$	-0.3 to +2.5	V
DTC pin allowable input voltage	$V_{DTC}$	2.5	V
Out pin allowable application voltage	$V_{OUT}$	35	V
Collector output current	$I_{OUT}$	100	mA
Power dissipation ( $T_a = 85^\circ\text{C}$ )	$P_D$	154	mW
Operating ambient temperature	$T_{opr}$	-30 to +85	$^\circ\text{C}$
Storage temperature	$T_{stg}$	-55 to +150	$^\circ\text{C}$

### ■ Recommended Operating Range at $T_a = 25^\circ\text{C}$

Parameter	Symbol	Min	Max	Unit
Supply voltage rise time (0 V to 3.6 V)	$t_r (V_{CC})$	10	—	$\mu\text{s}$
Collector output voltage	$V_{OUT}$	—	34	V
Collector output current	$I_{OUT}$	—	50	mA
Timing capacitance	$C_T$	100	1800	pF
Timing resistance	$R_T$	5.1	15	$\text{k}\Omega$
Oscillator frequency	$f_{OUT}$	20	500	kHz
Short-circuit protection time constant setting capacitor	$C_{SCP}$	1000	—	pF

**■ Electrical Characteristics at  $T_a = 25^\circ\text{C}$** 

Parameter	Symbol	Conditions	Min	Typ	Max	Unit
<b>U.V.L.O. block</b>						
Circuit operation start voltage	$V_{\text{UON}}$		2.8	3.1	3.4	V
Hysteresis width	$V_{\text{HYS}}$		100	200	300	mV
<b>Error amplifier block</b>						
Input threshold voltage	$V_{\text{TH}}$	Voltage follower	0.72	0.75	0.78	mV
Line regulation with input fluctuation	$V_{\text{dv}}$	Voltage follower, $V_{\text{CC}} = 3.6 \text{ V to } 34 \text{ V}$	—	2	8	mV
Input bias current	$I_{\text{B}}$		-500	-25	—	nA
High-level output voltage	$V_{\text{EH}}$		2.0	—	—	V
Low-level output voltage	$V_{\text{EL}}$		—	—	0.3	V
Input threshold voltage temperature characteristics 1	$V_{\text{dt1}}$	Voltage follower, $T_a = -30^\circ\text{C to } +25^\circ\text{C}$	—	$\pm 1$	—	%
Input threshold voltage temperature characteristics 2	$V_{\text{dt2}}$	Voltage follower, $T_a = -25^\circ\text{C to } +85^\circ\text{C}$	—	$\pm 1$	—	%
Output sink current	$I_{\text{SINK}}$	$V_{\text{FB}} = 0.9 \text{ V}$	—	8	—	mA
Output source current	$I_{\text{SOURCE}}$	$V_{\text{FB}} = 0.9 \text{ V}$	—	-120	—	$\mu\text{A}$
Open-loop gain	$A_{\text{V}}$		—	70	—	dB
<b>PWM comparator block</b>						
High-level input threshold voltage	$V_{\text{DT-H}}$	Duty: 100%	1.2	—	—	V
Low-level input threshold voltage	$V_{\text{DT-L}}$	Duty: 0%	—	—	0.6	V
Input current	$I_{\text{DTC}}$		-12	-11	-10	A
<b>Output block</b>						
Oscillation frequency	$f_{\text{OUT}}$	$R_{\text{T}} = 15 \text{ k}\Omega, C_{\text{T}} = 150 \text{ pF}$	185	205	225	kHz
Output duty	$D_{\text{u}}$	$R_{\text{DTC}} = 91 \text{ k}\Omega$	50	55	60	%
Output saturation voltage	$V_{\text{OL}}$	$I_{\text{O}} = 50 \text{ mA}, R_{\text{T}} = 15 \text{ k}\Omega$	—	0.9	1.2	V
Output leak current	$I_{\text{LEAK}}$	$V_{\text{CC}} = 34 \text{ V}$ , when output Tr is off	—	—	10	$\mu\text{A}$
RT pin voltage	$V_{\text{RT}}$		—	0.59	—	V
Maximum oscillation frequency	$f_{\text{OUT(max)}}$	$R_{\text{T}} = 5.1 \text{ k}\Omega, C_{\text{T}} = 120 \text{ pF}$	—	500	—	kHz
Frequency supply voltage characteristics	$f_{\text{dv}}$	$f_{\text{OUT}} = 200 \text{ kHz}$ , $V_{\text{CC}} = 3.6 \text{ V to } 34 \text{ V}$	—	$\pm 1$	—	%
Frequency temperature characteristics 1	$f_{\text{dT1}}$	$f_{\text{OUT}} = 200 \text{ kHz}$ , $T_a = -30^\circ\text{C to } +25^\circ\text{C}$	—	$\pm 3$	—	%
Frequency temperature characteristics 2	$f_{\text{dT2}}$	$f_{\text{OUT}} = 200 \text{ kHz}$ , $T_a = 25^\circ\text{C to } 85^\circ\text{C}$	—	$\pm 3$	—	%

Note) At  $V_{\text{CC}} = 12 \text{ V}$ ,  $R_{\text{T}} = 15 \text{ k}\Omega$ ,  $C_{\text{T}} = 15 \text{ pF}$ , unless otherwise specified.

■ Electrical Characteristics at  $T_a = 25^\circ\text{C}$  (continued)

Parameter	Symbol	Conditions	Min	Typ	Max	Unit
<b>Short-circuit protection circuit block</b>						
Input threshold voltage	$V_{THPC}$		0.70	0.75	0.80	V
Input standby voltage	$V_{STBY}$		—	—	120	V
Input latch voltage	$V_{IN}$		—	—	120	mV
Charge current	$I_{CHG}$	$V_{SCP} = 0\text{ V}$	-1.6	-1.3	-1.0	$\mu\text{A}$
Comparator threshold voltage	$V_{THL}$		—	1.90	—	V
<b>Overcurrent protection block</b>						
Input threshold voltage	$V_{CLM}$		$V_{CC}-120$	$V_{CC}-100$	$V_{CC}-80$	mV
Delay time	$t_{DLY}$		—	200	—	ns
<b>Whole device</b>						
Total consumption current 1	$I_{CC}$	$R_T = 15\text{ k}\Omega$	—	2.4	3.5	mA
Total consumption current 2	$I_{CC2}$	$R_T = 5.1\text{ k}\Omega, C_T = 150\text{ pF}$	—	3.4	—	mA

Note) At  $V_{CC} = 12\text{ V}$ ,  $R_T = 15\text{ k}\Omega$ ,  $C_T = 15\text{ pF}$ , unless otherwise specified.



■ Terminal Equivalent Circuits

Pin No.	Pin	I/O	Function	Internal equivalent circuit
1	CLM	I	Detects the overcurrent state in switching transistor. Insert a resistor with a low resistance between this pin and $V_{CC}$ to detect overcurrent states. When this pin falls to a level 100 mV or more lower than $V_{CC}$ , the PWM output is turned off for that period thus narrowing the width of the on period. (This implements a pulse-by-pulse overcurrent protection technique.)	
2	RT	I	Connection for the timing resistor that determines the oscillator frequency. Use a resistor in the range 5.1 kΩ to 15 kΩ. Thus the pin voltage will be about 0.59 V.	
3	CT	O	Connection for the timing capacitor that determines the oscillator frequency. Use a capacitor in the range 100 to 1800 pF. See the "Application Notes, [2] and [3]" sections later in this document for details on setting the frequency. Use an oscillator frequency in the range 20 kHz to 500 kHz.	

■ Terminal Equivalent Circuits (continued)

Pin No.	Pin	I/O	Function	Internal equivalent circuit
4	S.C.P.	O	<p>Connection for the capacitor that determines the time constant for soft start and the timer latch short-circuit protection circuit.</p> <p>Use a capacitor with a value of 1 000 pF or higher.</p> <p>The charge current <math>I_{CHG}</math> is determined by the timing resistor <math>R_T</math>, and sample-to-sample and temperature variations can be suppressed.</p> <p>When <math>R_T</math> is 15 k<math>\Omega</math>, the current will be about -1.3 <math>\mu</math>A.</p> $I_{CHG} = \frac{V_{RT}}{R_T} \times \frac{1}{30} \text{ [A]}$	
5	DTC	I	<p>Connection for the resistor and capacitor that determine the PWM output dead-time and the soft start period.</p> <p>The input current <math>I_{DTC}</math> is determined by the timing resistor <math>R_T</math>, and sample-to-sample and temperature variations can be suppressed.</p> <p>When <math>R_T</math> is 15 k<math>\Omega</math>, the current will be about -11 <math>\mu</math>A.</p> $I_{CHG} = \frac{V_{RT}}{R_T} \times \frac{1}{3.6} \text{ [A]}$	
6	FB	O	<p>Error amplifier output</p> <p>A source current is about -120 mA and a sink current is about 8 mA.</p> <p>Correct the gain and the phase frequency characteristics by inserting a resistor and a capacitor between this pin and IN- pin.</p>	
7	IN-	I	<p>Error amplifier inverting input</p> <p>For common-mode input, use in the range -0.1 V to +0.8 V.</p>	
8	GND	—	Ground	

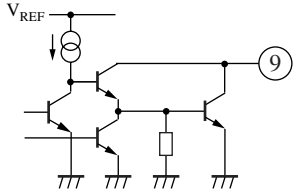
■ Terminal Equivalent Circuits (continued)

Pin No.	Pin	I/O	Function	Internal equivalent circuit
9	Out	O	Open-collector (darlington) output The absolute maximum rating for the output current is 100 mA. Use with a constant output current under 50 mA.	
10	V <sub>CC</sub>	—	Power supply connection Provide the operating supply voltage in the range 3.6 V to 34 V.	

■ Application Notes

[1] Main characteristics

Error amplifier input threshold voltage temperature characteristics

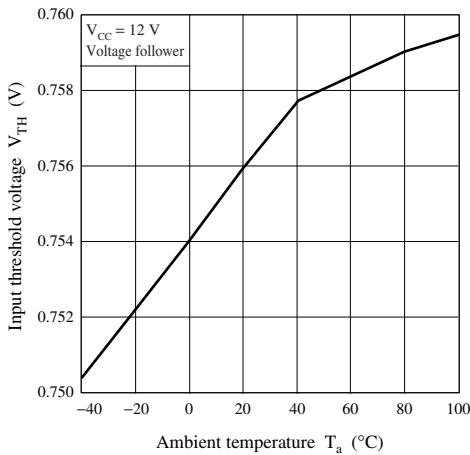

Maximum duty ratio temperature characteristics

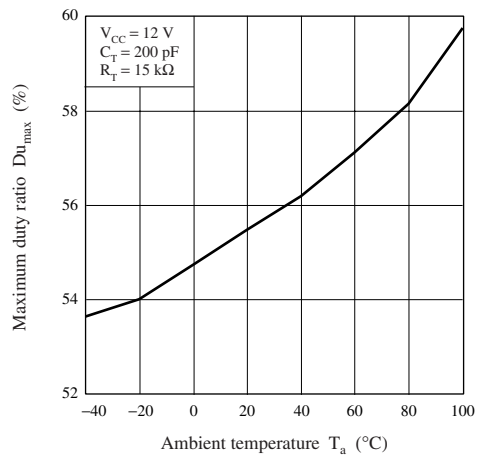

Oscillator frequency temperature characteristics

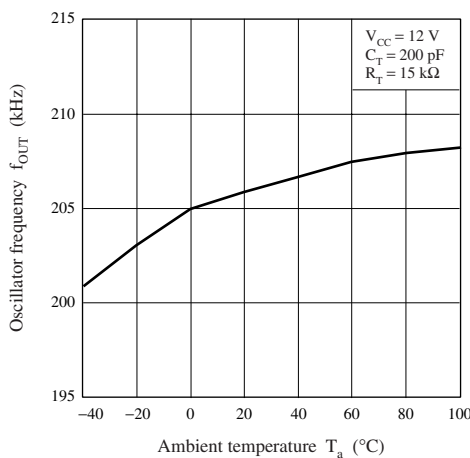

Timing capacitance — Oscillator frequency

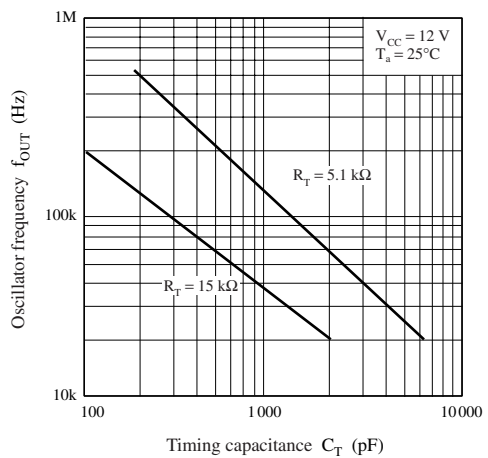

■ Application Notes (continued)

[1] Main characteristics (continued)

Input threshold voltage line regulation

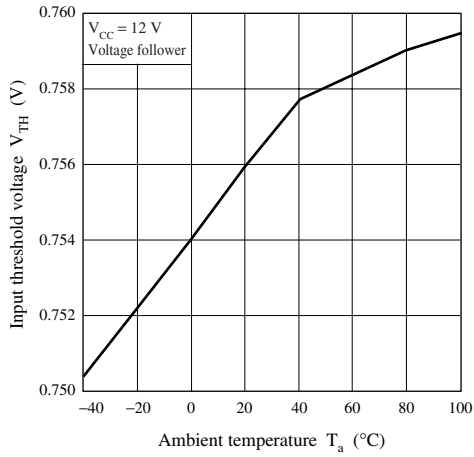

Total consumption current line regulation

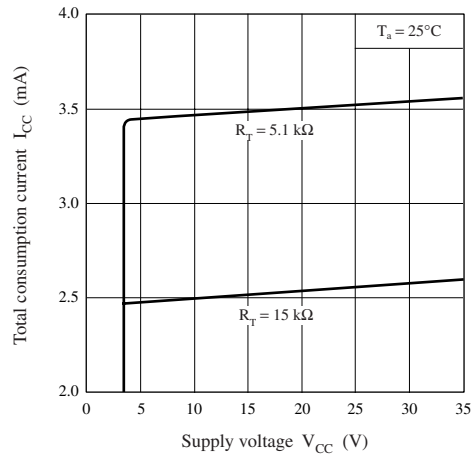

Timing resistance — Total consumption current

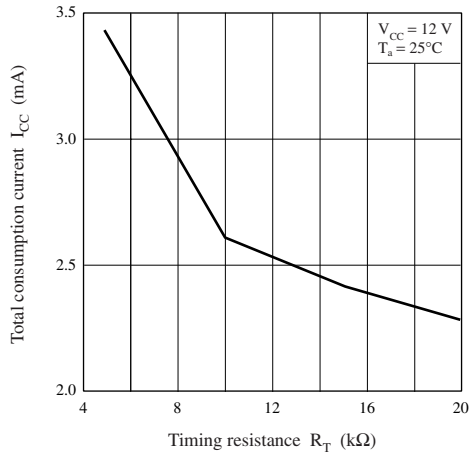

Timing resistance — Output saturation voltage

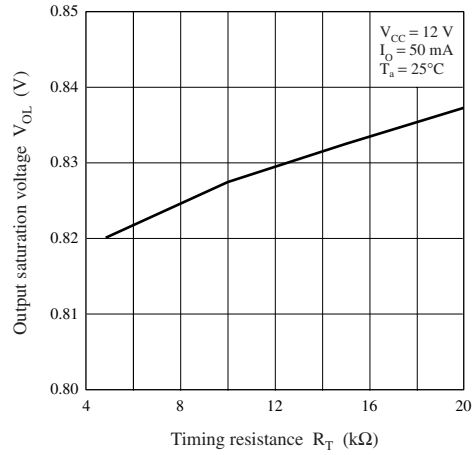

## ■ Application Notes

### [2] Function descriptions

#### 1. Reference voltage block

The reference voltage block is based on a band gap circuit, and outputs a temperature corrected reference voltage of 2.5 V. This reference voltage is stabilized once the supply voltage exceeds 3.6 V, and is used as the power supply for the IC itself.

#### 2. Triangular wave generator

This circuit generates a triangular wave with a peak of about 1.45 V and a trough of about 0.35 V using a timing capacitor connected to the CT pin (pin 3) and a timing resistor connected to the RT pin (pin 2) respectively. The oscillator frequency can be set to arbitrary value by selecting appropriate values for the external capacitor and resistor,  $C_T$  and  $R_T$ . The triangular wave signal is provided to the inverting input the PWM comparator internally to the IC.

#### 3. Error amplifier

This circuit is an pnp-transistor input error amplifier that detects and amplifies the DC-DC converter output voltage, and inputs that signal to a PWM comparator.

A 0.75 V level is created by resistors dividing the internal reference voltage. This level is applied to the noninverting input.

Arbitrary gain and phase compensation can be set up by inserting a resistor and capacitor in series between the error amplifier output pin (pin 6) and the inverting input pin (pin 7).

The output voltage  $V_{OUT}$  is given by the following formula by connecting a resistor divider to the output as shown in figure 1.

$$V_{OUT} = 0.75 \times \frac{R1 + R2}{R2}$$

#### 4. Timer latch short-circuit protection circuit

This circuit protects the external main switching element, flywheel diode, choke coil, and other components against degradation or destruction if an excessive load or a short circuit of the power supply output continues for longer than a certain fixed period.

The timer latch short-circuit protection circuit detects the output of the error amplifier. If the DC-DC converter output voltage drops and an error amplifier output level exceeds 1.90 V, this circuit outputs a low level and the timer circuit starts. This starts charging the external protection circuit delay time capacitor.

If the error amplifier output does not return to the normal voltage range before that capacitor reaches 0.75 V, the latch circuit latches, the output drive transistors are turned off, and the dead-time is set to 100%.

#### 5. Low input voltage malfunction prevention circuit (U.V.L.O.)

This circuit protects the system against degradation or destruction due to incorrect control operation when the power supply voltage falls during power on or power off.

The low input voltage malfunction prevention circuit detects the internal reference voltage that changes with the supply voltage level. While the supply voltage is rising, this circuit cuts off the output drive transistor until the reference voltage reaches 3.1 V. It also sets the dead-time to 100%, and at the same time holds the S.C.P. pin (pin 4) at the low level. During the fall time of the power supply voltage, it has hysteresis width of 200 mV and operates 2.9 V or less.

#### 6. PWM comparator

The PWM comparator controls the output pulse on-period according to the input voltage. The output transistor is turned on during periods when the level of the CT pin (pin 3) triangular wave is lower than both of the error amplifier output (pin 6) and the DTC pin (pin 5) voltage.

The dead-time is set by adding a resistor between the DTC pin and ground.

Additionally, the AN8013SH can provide soft start operation in which the output pulse on-period is gradually lengthened according to an RC time constant when power is first applied by adding a capacitor in parallel with the resistor  $R_{DTC}$ .

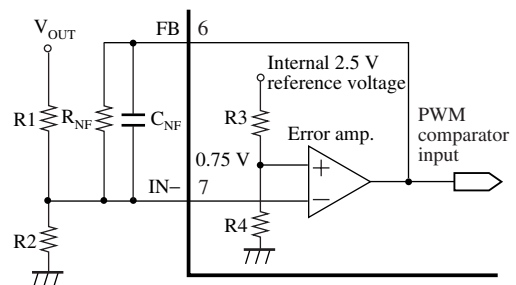

Figure 1. Connection method of error amplifier



## ■ Application Notes (continued)

### [2] Function descriptions (continued)

#### 7. Overcurrent protection block

Destruction of the main switching device, the flywheel diode, and the choke coil, which are easily damaged by overcurrents, is prevented by limiting the maximum current that flows in the switching device. This is implemented using the fact that power supply output overcurrents are proportional to the current flowing in the main switching device (a bipolar transistor).

The AN8013SH detects the current by connecting a resistor with a low resistance between the main switching device and the  $V_{CC}$  pin and monitoring the voltage drop across this resistor at the CLM pin (pin 1). When the main switching device (a bipolar transistor) is on and the CLM pin voltage reaches  $V_{CC}$  minus 100 mV, which is the overcurrent detection threshold voltage, the AN8013SH shuts off the output transistor, thus controlling the main switching device so that currents in excess of the limit cannot occur. While this control operation is repeated at each period, once an overcurrent is detected the output transistor is turned off for the remainder of that period and is not turned on again until the next period. This type of overcurrent protection is called pulse-by-pulse overcurrent protection.

#### 8. Output block

The output drive transistor is of open-collector type output in which transistors are darlington-connected with a grounded common emitter. The breakdown voltage of collector output terminal (pin 5) is 34 V and it is possible to obtain up to 100 mA output current.

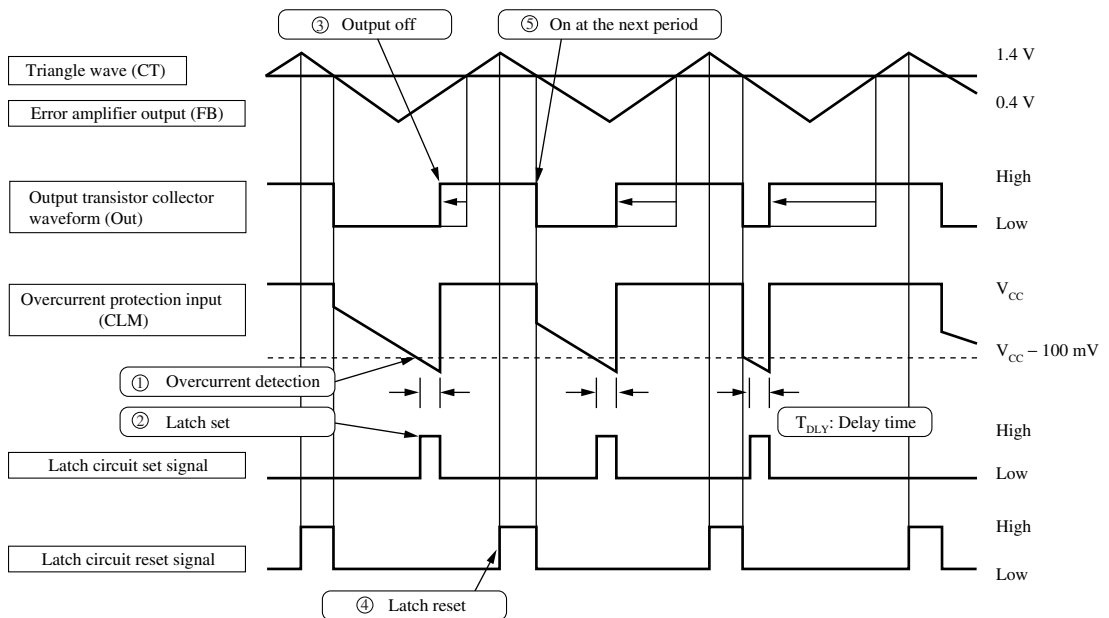

Figure 2. Pulse-by-pulse overcurrent protection operating waveforms

### [3] Triangular wave oscillation circuit

#### 1. Setting the oscillator frequency

The waveform of triangular wave oscillation is obtained by charging and discharging of the constant current  $I_O$  from the external timing capacitor  $C_T$  which is connected to CT pin (pin 3). The constant current is set by the externally attached timing resistor  $R_T$ .

The peak value of the wave  $V_{CTH}$  and the trough value of the wave  $V_{CTL}$  are fixed at about 1.45 V typical and 0.35 V typical respectively.

■ Application Notes (continued)

[3] Triangular wave oscillation circuit (continued)

1. Setting the oscillator frequency (continued)

The oscillator frequency  $f_{OSC}$  is obtained by the following formula:

$$f_{OSC} = \frac{1}{t_1 + t_2} = \frac{I_O}{2 \times C_T \times (V_{CTH} - V_{CTL})}$$

whereas  $I_O = 1.8 \times \frac{V_{RT}}{R_T} = 1.8 \times \frac{0.59}{R_T}$

because  $V_{CTH} - V_{CTL} = 1.1 \text{ V}$

$$f_{OSC} = \frac{1}{2.07 \times C_T \times R_T} \text{ [Hz]}$$

The output frequency  $f_{OUT}$  is equal to  $f_{OSC}$  since it is PWM-controlled.

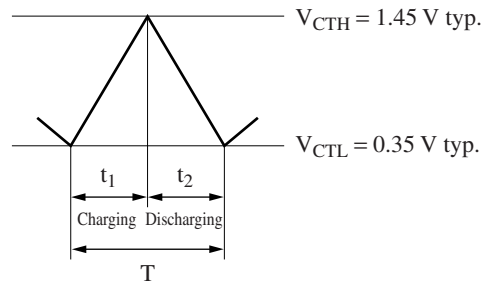

Figure 3. Triangular wave oscillation waveform

2. Usage notes

This IC uses the constant current given by the timing resistor  $R_T$  as the bias current of the triangular wave generator and the PWM comparator for consumption current reduction. The total consumption current is about 2.4 mA typical when  $R_T$  is 15 k $\Omega$ , and it increases to about 3.4 mA typical when  $R_T$  is 5.1 k $\Omega$ . In order to obtain the constant output current of 100 mA at the open-collector output, it is necessary to set  $R_T$  value to 15 k $\Omega$  or smaller.

It is possible to use the circuit in the recommended operating range of 20 kHz to 500 kHz of the oscillator frequency. As the AN8013SH is used at increasingly higher frequencies, the amount of overshoot and undershoot due to the operation delay in the triangular wave oscillator comparator increases, and discrepancies between the values calculated as described previously and the actual values may occur. See the timing capacitance - oscillator frequency relationship in the "Application Notes, [1] Main characteristics" section of this document.

Note that this IC can not be used as an IC for slave when the several ICs are operated in parallel synchronous mode.

[4] Setting the dead-time (maximum duty)

The dead-time is set, as shown in figure 4, by setting the DTC pin (pin 5) voltage,  $V_{DTC}$ . Since the DTC pin has a constant current output set with the resistor  $R_T$ ,  $V_{DTC}$  is adjusted by adding the external resistor  $R_{DTC}$ . The output duty,  $Du$ , and the DTC pin voltage,  $V_{DTC}$ , are expressed by the following formulas. For an oscillator frequency of 200 kHz, the output duty will be 0% at  $V_{DTC} = 0.45 \text{ V}$ , and 100% at  $V_{DTC} = 1.45 \text{ V}$ . However, care is required here, since the amount of overshoot and undershoot in the triangular wave peak ( $V_{CTH}$ ) and minimum ( $V_{CTL}$ ) values depends on the oscillator frequency.

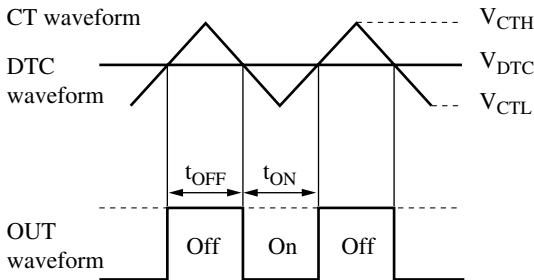

$$Du = \frac{t_{ON}}{t_{ON} + t_{OFF}} \times 100 \text{ [%]}$$

$$= \frac{V_{CTH} - V_{DTC}}{V_{CTH} - V_{CTL}} \times 100 \text{ [%]}$$

$$V_{DTC} = I_{DTC} \times R_{DTC}$$

$$= V_{RT} \times \frac{R_{DTC}}{R_T} \times \frac{1}{3.6} \text{ [V]}$$

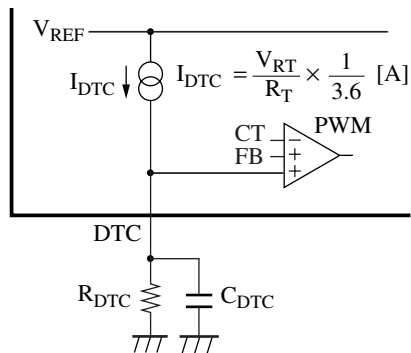

Example: When  $f_{OSC} = 200 \text{ kHz}$  ( $R_T = 15 \text{ k}\Omega$ ,  $C_T = 150 \text{ pF}$ )  
 $V_{CTH} \approx 1.45 \text{ V (typ.)}$   $V_{RT} \approx 0.59 \text{ V (typ.)}$   
 $V_{CTL} \approx 0.35 \text{ V (typ.)}$   $I_{DTC} \approx 11 \mu\text{A (typ.)}$

Figure 4. Setting the dead-time

## ■ Application Notes (continued)

### [4] Setting the dead-time (maximum duty) (continued)

Adding the external resistor  $R_{DTC}$  and the capacitor  $C_{DTC}$  in parallel implements a soft start function that causes the output pulse on width to increase gradually when the power supply is started. Use of this function can prevent DC-DC converter output overshoot.

### [5] Setting the time constant of the timer latch short-circuit protection circuit

The structural block diagram of protection latch circuit is shown in figure 5. The comparator for short-circuit protection compares the output of error amplifier  $V_{FB}$  with the reference voltage of 1.90 V all the time.

When the load conditions of DC-DC converter output are stabilized, there is no fluctuation of error amplifier output, and the short-circuit protection comparator also keeps the balance. At this moment, the output transistor Q1 is in the conductive state and the S.C.P. pin is hold to about 30 mV through the clamp circuit.

When the load conditions suddenly change, and high-level signal (1.90 V or higher) is input from the error amplifier to the non-inverted input of the short-circuit protection comparator, the short-circuit protection comparator outputs the low-level signal. Since this signal cuts off the output transistor Q1, the S.C.P. pin voltage  $V_{PE}$  is released, and the externally connected capacitor  $C_S$  starts charging according to the following equation:

$$V_{PE} = V_{STBY} + I_{CHG} \times \frac{t_{PE}}{C_S} \text{ [V]}$$

$$0.75 \text{ V} = 0.03 \text{ V} + I_{CHG} \times \frac{t_{PE}}{C_S}$$

$$C_S = I_{CHG} \times \frac{t_{PE}}{0.72} \text{ [F]}$$

$I_{CHG}$  is the constant current determined by the oscillation timing resistor  $R_T$ , and its dispersion and fluctuation with temperature are small.  $I_{CHO}$  is expressed in the following equation:

$$I_{CHG} = \frac{V_{RT}}{R_T} \times \frac{1}{30} \text{ [A]}$$

$V_{RT}$  is about 0.5 V and  $I_{CHO}$  becomes about 1.1  $\mu\text{A}$  at  $R_T = 15 \text{ k}\Omega$ .

Once the low input voltage malfunction prevention circuit is enabled, the S.C.P. pin voltage is discharged to about 30 mV but the latch circuit is not reset unless the power is turned off.

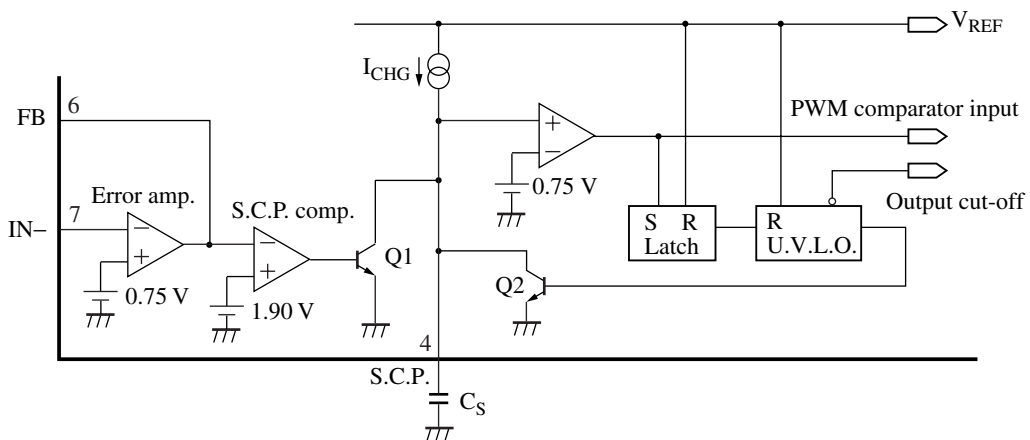

Figure 5. Short-circuit protection circuit

When the power supply is started, the output appears to be shorted. The error amplifier output goes to the high state, the S.C.P. pin voltage,  $V_{PE}$ , is released, and charging starts. The external capacitor value must be set so that DC-DC converter voltage output starts before the latch circuit in the later stage is set. If the soft start function is used, special care is required to assure that the start time does not become excessive.

■ Application Notes (continued)

[6] Timing chart

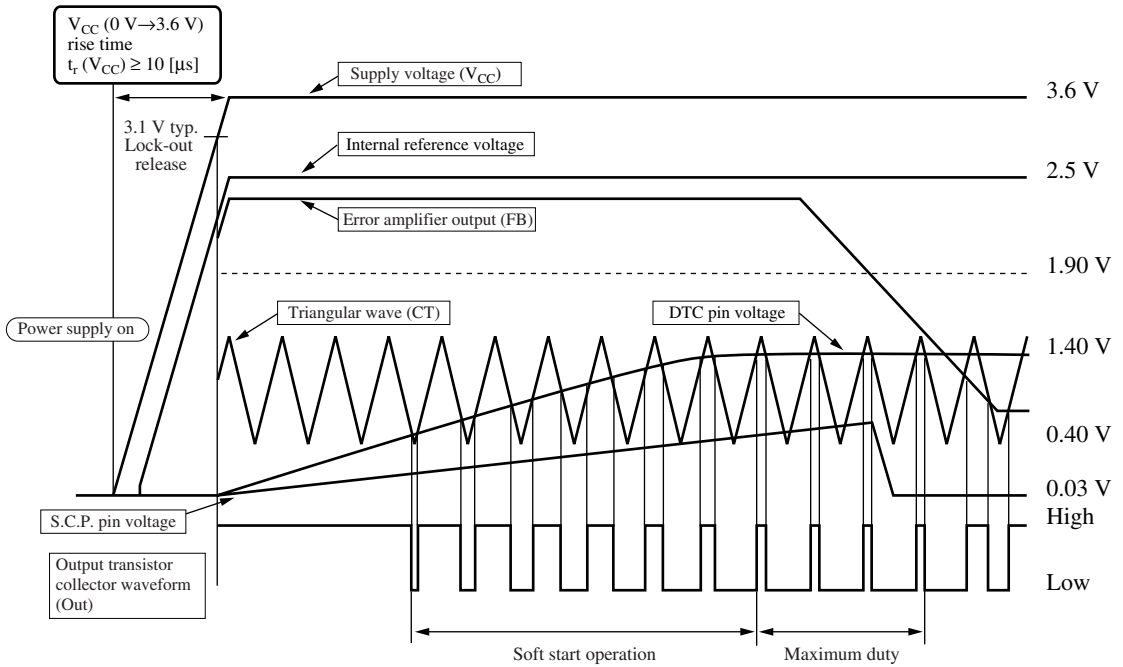

Figure 6. PWM comparator operation waveform

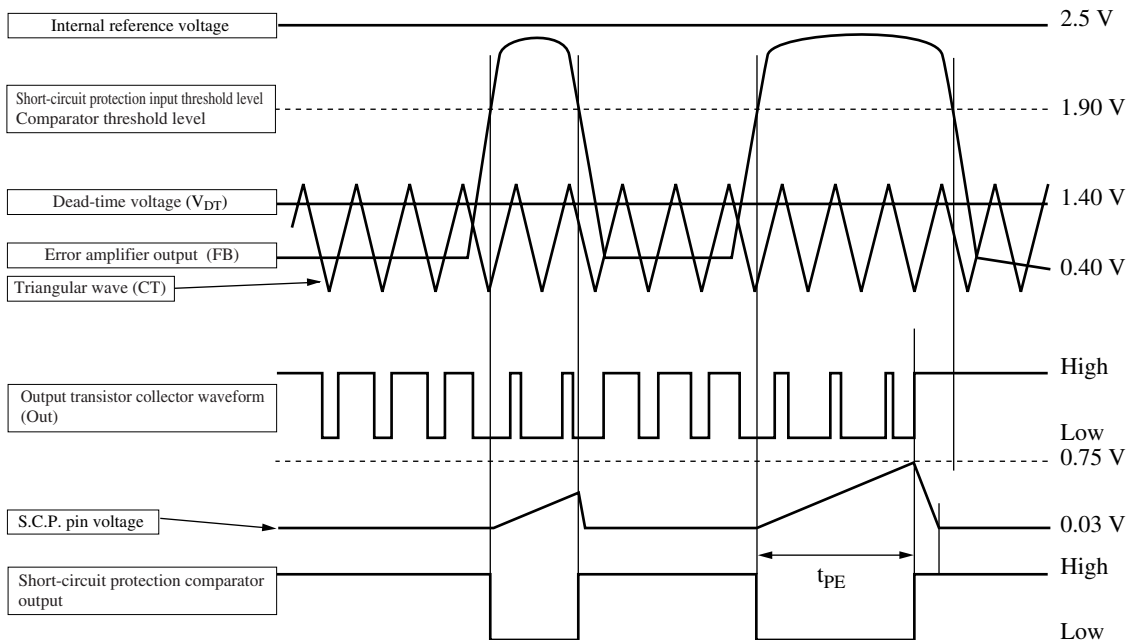
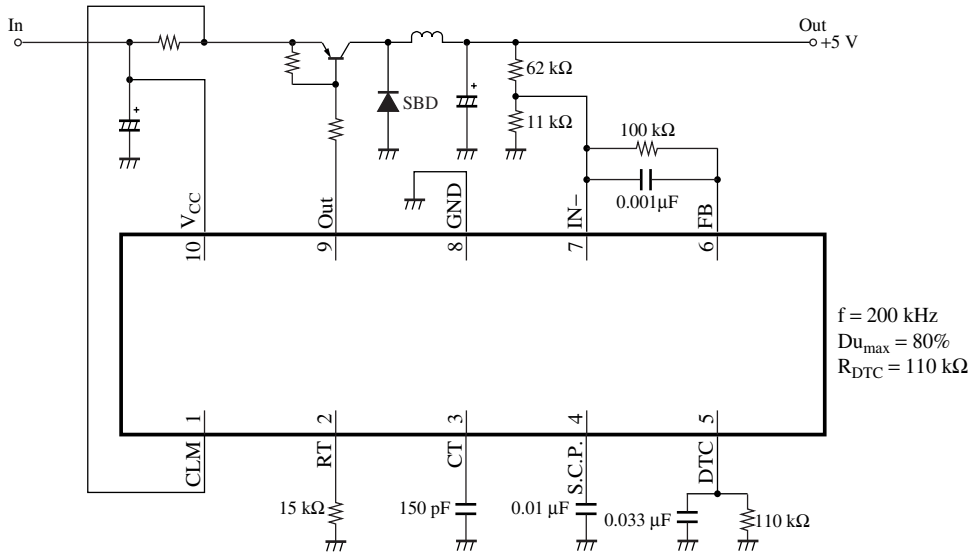

Figure 7. Short-circuit protection operation waveform

■ Application Circuit Examples

1. Step-down circuit



2. Step-up circuit

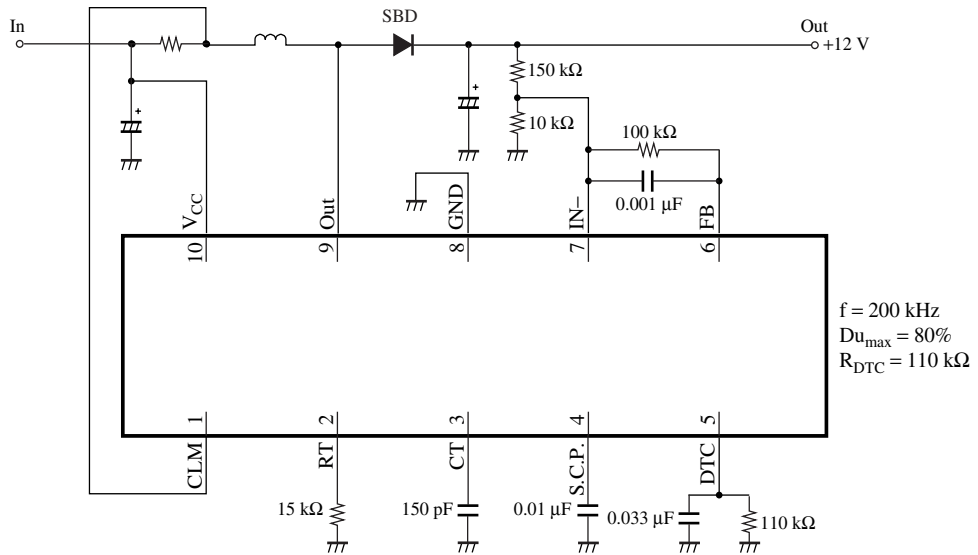

## ■ Application Circuit Examples (continued)

### 3. On/off circuit example

#### 1) Cutting the power supply line

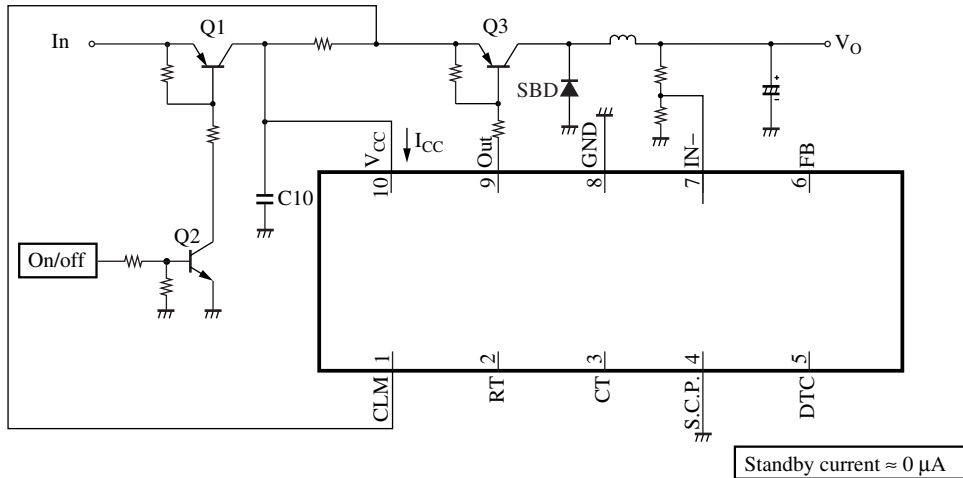

#### 2) Cutting the IC $V_{CC}$ line

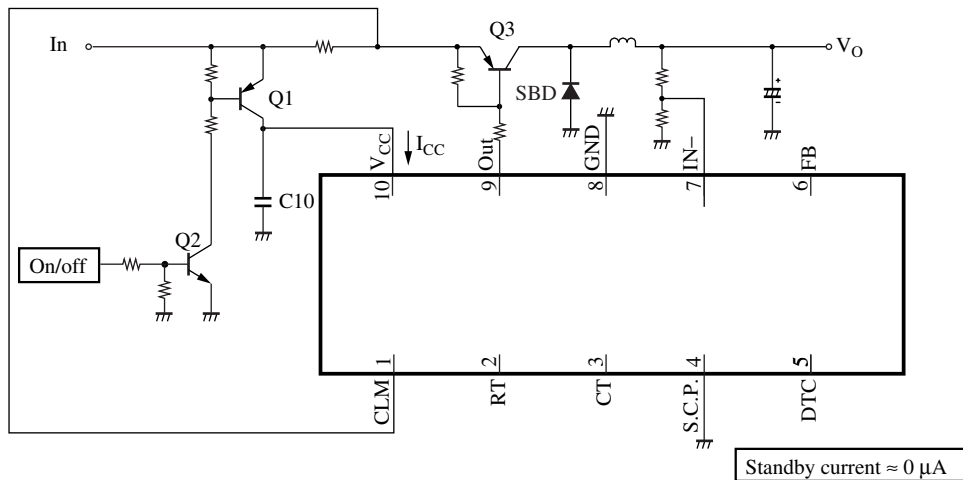

### 4. Usage

Since this IC does not include an on/off circuit, an external circuit must be added to implement a standby function.

If a switch (Q1) is inserted in the power supply line as shown in on/off circuit example 1, the standby current can be held to 0. In this circuit, a transistor essentially equivalent to the one used for the main switching device (Q3) is required.

If a switch (Q1) is inserted between the power supply line and the IC  $V_{CC}$  pin (pin 10) as shown in on/off circuit example 2, the size of the switching device (Q1) can be reduced. However, the sample-to-sample variations in the Q1 saturation voltage will result in sample-to-sample variations in the overcurrent protection threshold level.

### 5. Usage Notes

If an external on/off circuit is added, the  $V_{CC}$  rise time may become excessively steep and the IC internal latch circuit may be set at that time, causing problems at power supply startup. To avoid such problems, set the value of C10 so that the  $V_{CC}$  (pin 10) rise time is at least 10  $\mu$ s.

## Request for your special attention and precautions in using the technical information and semiconductors described in this material

- (1) An export permit needs to be obtained from the competent authorities of the Japanese Government if any of the products or technologies described in this material and controlled under the "Foreign Exchange and Foreign Trade Law" is to be exported or taken out of Japan.
- (2) The technical information described in this material is limited to showing representative characteristics and applied circuit examples of the products. It does not constitute the warranting of industrial property, the granting of relative rights, or the granting of any license.
- (3) The products described in this material are intended to be used for standard applications or general electronic equipment (such as office equipment, communications equipment, measuring instruments and household appliances).  
Consult our sales staff in advance for information on the following applications:
  - Special applications (such as for airplanes, aerospace, automobiles, traffic control equipment, combustion equipment, life support systems and safety devices) in which exceptional quality and reliability are required, or if the failure or malfunction of the products may directly jeopardize life or harm the human body.
  - Any applications other than the standard applications intended.
- (4) The products and product specifications described in this material are subject to change without notice for reasons of modification and/or improvement. At the final stage of your design, purchasing, or use of the products, therefore, ask for the most up-to-date Product Standards in advance to make sure that the latest specifications satisfy your requirements.
- (5) When designing your equipment, comply with the guaranteed values, in particular those of maximum rating, the range of operating power supply voltage and heat radiation characteristics. Otherwise, we will not be liable for any defect which may arise later in your equipment.  
Even when the products are used within the guaranteed values, redundant design is recommended, so that such equipment may not violate relevant laws or regulations because of the function of our products.
- (6) When using products for which dry packing is required, observe the conditions (including shelf life and after-unpacking standby time) agreed upon when specification sheets are individually exchanged.
- (7) No part of this material may be reprinted or reproduced by any means without written permission from our company.

## Please read the following notes before using the datasheets

- A. These materials are intended as a reference to assist customers with the selection of Panasonic semiconductor products best suited to their applications.  
Due to modification or other reasons, any information contained in this material, such as available product types, technical data, and so on, is subject to change without notice.  
Customers are advised to contact our semiconductor sales office and obtain the latest information before starting precise technical research and/or purchasing activities.
- B. Panasonic is endeavoring to continually improve the quality and reliability of these materials but there is always the possibility that further rectifications will be required in the future. Therefore, Panasonic will not assume any liability for any damages arising from any errors etc. that may appear in this material.
- C. These materials are solely intended for a customer's individual use.  
Therefore, without the prior written approval of Panasonic, any other use such as reproducing, selling, or distributing this material to a third party, via the Internet or in any other way, is prohibited.