



Spread Spectrum FTG for VIA K7 Chipset

Features

- Maximized EMI Suppression using Cypress's Spread Spectrum technology
- Single chip system frequency synthesizer for VIA K7 chipset
- Two copies of CPU output
- Six copies of PCI output
- One 48-MHz output for USB
- One 24-MHz or 48-MHz output for SIO
- Two buffered reference outputs
- Thirteen SDRAM outputs provide support for 3 DIMMs
- Supports frequencies up to 200 MHz
- I²C interface for programming
- Power management control inputs
- Available in 48-pin SSOP

Key Specifications

CPU Cycle-to-Cycle Jitter: 250 ps
 CPU to CPU Output Skew: 175 ps
 PCI to PCI Output Skew: 500 ps
 V_{DDQ3}: 3.3V±5%
 SDRAMIN to SDRAM0:12 Delay: 3.7 ns typ.

Table 1. Mode Input Table

Mode	Pin 2
0	CPU_STOP#
1	REF0

Table 2. Pin Selectable Frequency

Input Address				CPUT_CS CPU0 (MHz)	PCI_F, 1:5 (MHz)	Spread Spectrum
FS3	FS2	FS1	FS0			
1	1	1	1	100.0	33.3	-0.5%
1	1	1	0	100.0	33.3	±0.25%
1	1	0	1	100.0	33.3	±0.5%
1	1	0	0	95.0	31.7	OFF
1	0	1	1	133.3	33.3	-0.5%
1	0	1	0	133.3	33.3	±0.25%
1	0	0	1	133.3	33.3	±0.5%
1	0	0	0	102.0	34.0	OFF
0	1	1	1	104.0	34.6	OFF
0	1	1	0	106.0	35.3	OFF
0	1	0	1	107.0	35.6	OFF
0	1	0	0	108.0	36.0	OFF
0	0	1	1	109.0	36.3	OFF
0	0	1	0	110.0	36.6	OFF
0	0	0	1	111.0	37.0	OFF
0	0	0	0	112.0	37.3	OFF

Block Diagram

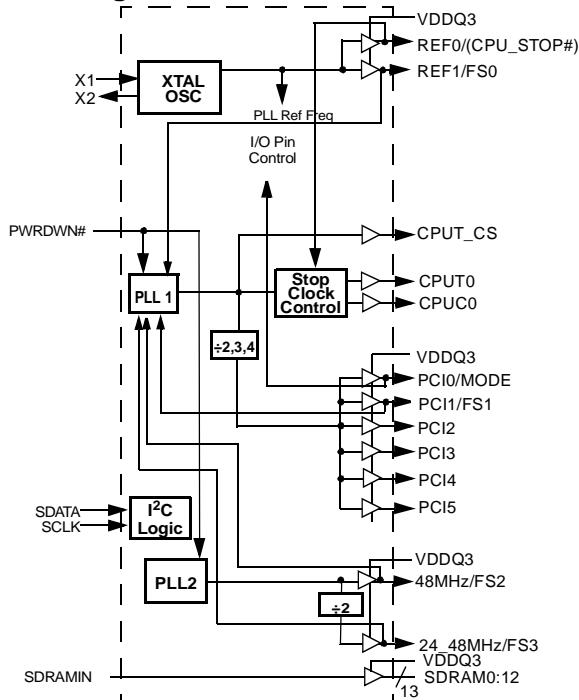

Pin Configuration^[1]

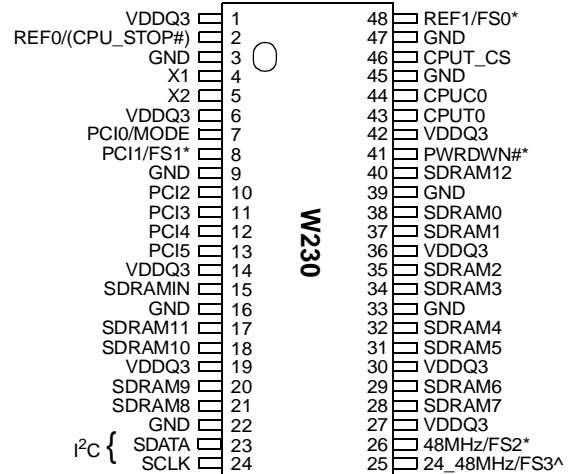

Note:

1. Internal pull-up resistors should not be relied upon for setting I/O pins HIGH. Pin function with parentheses determined by MODE pin resistor strapping. Unlike other I/O pins, input FS3 has an internal pull-down resistor.

I²C is a trademark of Phillips Corporation.

Pin Definitions

Pin Name	Pin No.	Pin Type	Pin Description
CPUT0, CPUC0, CPUT_CS	43, 44, 46	O (open- drain)	CPU Clock Output 0: CPUT0 and CPUC0 are the differential CPU clock outputs for the K7 processor. CPUT_CS is the open-drain clock output for the chipset. It has the same phase relationship as CPUT0.
PCI2:5	10, 11, 12, 13	O	PCI Clock Outputs 2 through 5: These four PCI clock outputs are controlled by the PWRDWN# control pin. Frequency is set by FS0:3 inputs or through serial input interface, see <i>Tables 2 and 6</i> for details. Output voltage swing is controlled by voltage applied to VDDQ3.
PCI1/FS1	8	I/O	Fixed PCI Clock Output/Frequency Select 1: As an output, frequency is set by FS0:3 inputs or through serial input interface. This output is controlled by the PWRDWN# input. This pin also serves as a power-on strap option to determine device operating frequency as described in <i>Table 2</i> .
PCI0/MODE	7	I/O	Fixed PCI Clock Output/Mode: As an output, frequency is set by the FS0:3 inputs or through serial input interface, see <i>Tables 2 and 6</i> . This output is controlled by the PWRDWN# input. This pin also serves as a power-on strap option to determine the function of pin 2, see <i>Table 1</i> for details.
PWRDWN#	41	I	PWRDWN# Input: LVTTTL-compatible input that places the device in power-down mode when held LOW. In power-down mode, CPUC0 will be three-stated and all the other output clocks will be driven LOW.
48MHz/FS2	26	I/O	48-MHz Output/Frequency Select 2: 48 MHz is provided in normal operation. In standard PC systems, this output can be used as the reference for the Universal Serial Bus host controller. This pin also serves as a power on strap option to determine device operating frequency as described in <i>Table 2</i> .
24_48MHz/ FS3	25	I/O	24_48-MHz Output/Frequency Select 3: In standard PC systems, this output can be used as the clock input for a Super I/O chip. The output frequency is controlled by Configuration Byte 3 bit[6]. The default output frequency is 48 MHz. This pin also serves as a power-on strap option to determine device operating frequency as described in <i>Table 2</i> .
REF1/FS0	48	I/O	Reference Clock Output 1/Frequency Select 2: 3.3V 14.318-MHz output clock. This pin also serves as a power-on strap option to determine device operating frequency as described in <i>Table 2</i> . Upon power-up, FS0 input will be latched which will set clock frequencies as described in <i>Table 2</i> .
REF0/ CPU_STOP#	2	I/O	Reference Clock Output 0 or CPU_STOP# Input Pin: Function is determined by the MODE pin. When CPU_STOP# input is asserted LOW, it will drive CPUT0 and CPUT_CS to logic 0, and it will three-state CPUC0. When this pin is configured as an output, this pin becomes a 3.3V 14.318-MHz output clock.
SDRAMIN	15	I	Buffered Input Pin: The signal provided to this input pin is buffered to 13 outputs (SDRAM0:12).
SDRAM0:12	38, 37, 35, 34, 32, 31, 29, 28, 21, 20, 18, 17, 40	O	Buffered Outputs: These thirteen dedicated outputs provide copies of the signal provided at the SDRAMIN input. The swing is set by VDDQ3, and they are deactivated when PWRDWN# input is set LOW.
SCLK	24	I	Clock pin for I ² C circuitry.
SDATA	23	I/O	Data pin for I ² C circuitry.
X1	4	I	Crystal Connection or External Reference Frequency Input: This pin has dual functions. It can be used as an external 14.318-MHz crystal connection or as an external reference frequency input.
X2	5	I	Crystal Connection: An input connection for an external 14.318-MHz crystal. If using an external reference, this pin must be left unconnected.
VDDQ3	1, 6, 14, 19, 27, 30, 36, 42	P	Power Connection: Power supply for core logic, PLL circuitry, SDRAM outputs, PCI outputs, reference outputs, 48-MHz output, and 24_48-MHz output. Connect to 3.3V supply
GND	3, 9, 16, 22, 33, 39, 45, 47	G	Ground Connections: Connect all ground pins to the common system ground plane.

Overview

The W230 was developed as a single-chip device to meet the clocking needs of VIA K7 core logic chip sets. In addition to the typical outputs provided by a standard FTG, the W230 adds a thirteenth output buffer, supporting SDRAM DIMM modules in conjunction with the chipset.

Cypress's proprietary spread spectrum frequency synthesis technique is a feature of the CPU and PCI outputs. When enabled, this feature reduces the peak EMI measurements of not only the output signals and their harmonics, but also of any other clock signals that are properly synchronized to them.

Functional Description

I/O Pin Operation

Pins 7, 8, 25, 26, and 48 are dual-purpose I/O pins. Upon power-up these pins act as logic inputs, allowing the determination of assigned device functions. A short time after power-up, the logic state of each pin is latched and the pins become clock outputs. This feature reduces device pin count by combining clock outputs with input select pins.

An external 10-k Ω "strapping" resistor is connected between the I/O pin and ground or V_{DD} . Connection to ground sets a latch to "0," connection to V_{DD} sets a latch to "1." *Figure 1* and *Figure 2* show two suggested methods for strapping resistor connections.

Upon W230 power-up, the first 2 ms of operation is used for input logic selection. During this period, the five I/O pins (7, 8, 25, 26, 48) are three-stated, allowing the output strapping resistor on the I/O pins to pull the pins and their associated capacitive clock load to either a logic HIGH or LOW state. At the end of the 2-ms period, the established logic "0" or "1" condition of the I/O pin is latched. Next the output buffer is enabled converting the I/O pins into operating clock outputs. The 2-ms timer starts when V_{DD} reaches 2.0V. The input bits can only be reset by turning V_{DD} off and then back on again.

It should be noted that the strapping resistors have no significant effect on clock output signal integrity. The drive impedance of clock outputs is <40 Ω (nominal), which is minimally affected by the 10-k Ω strap to ground or V_{DD} . As with the series termination resistor, the output strapping resistor should be placed as close to the I/O pin as possible in order to keep the interconnecting trace short. The trace from the resistor to ground or V_{DD} should be kept less than two inches in length to prevent system noise coupling during input logic sampling.

When the clock outputs are enabled following the 2-ms input period, the specified output frequency is delivered on the pin, assuming that V_{DD} has stabilized. If V_{DD} has not yet reached full value, output frequency initially may be below target but will increase to target once V_{DD} voltage has stabilized. In either case, a short output clock cycle may be produced from the CPU clock outputs when the outputs are enabled.

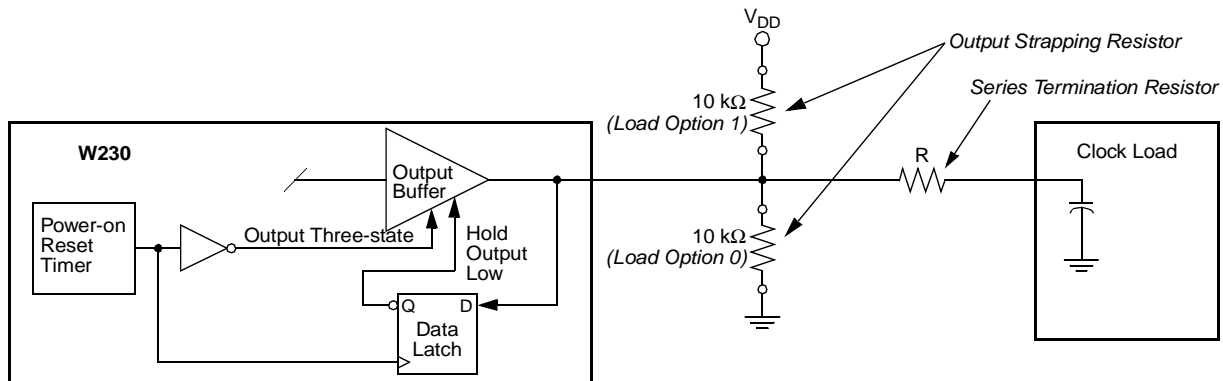

Figure 1. Input Logic Selection Through Resistor Load Option

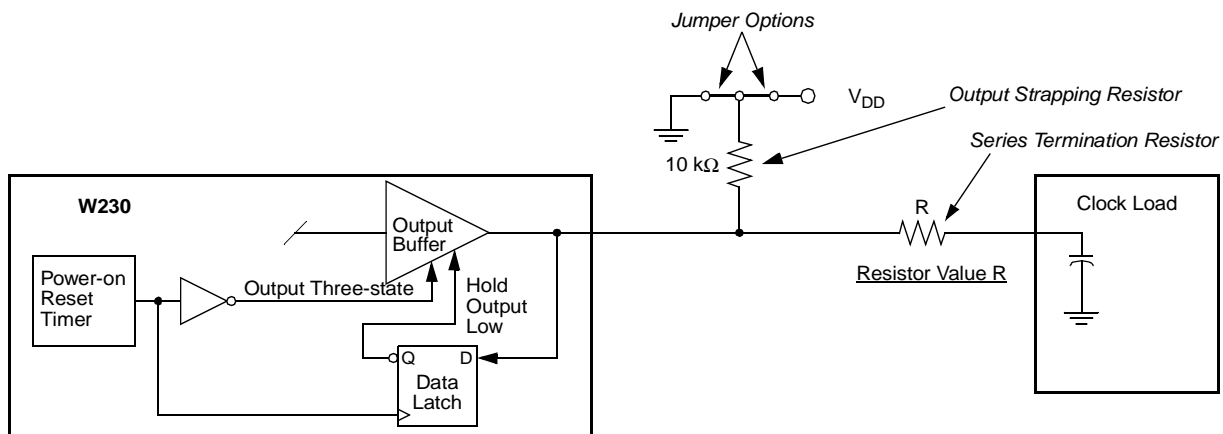

Figure 2. Input Logic Selection Through Jumper Option

Spread Spectrum Frequency Timing Generator

The device generates a clock that is frequency modulated in order to increase the bandwidth that it occupies. By increasing the bandwidth of the fundamental and its harmonics, the amplitudes of the radiated electromagnetic emissions are reduced. This effect is depicted in *Figure 3*.

As shown in *Figure 3*, a harmonic of a modulated clock has a much lower amplitude than that of an unmodulated signal. The reduction in amplitude is dependent on the harmonic number and the frequency deviation or spread. The equation for the reduction is

$$dB = 6.5 + 9 \cdot \log_{10}(P) + 9 \cdot \log_{10}(F)$$

Where *P* is the percentage of deviation and *F* is the frequency in MHz where the reduction is measured.

The output clock is modulated with a waveform depicted in *Figure 4*. This waveform, as discussed in "Spread Spectrum Clock Generation for the Reduction of Radiated Emissions" by Bush, Fessler, and Hardin produces the maximum reduction in the amplitude of radiated electromagnetic emissions. The deviation selected for this chip is specified in *Table 6*. *Figure 4* details the Cypress spreading pattern. Cypress does offer options with more spread and greater EMI reduction. Contact your local Sales representative for details on these devices.

Spread Spectrum clocking is activated or deactivated by selecting the appropriate values for bits 1–0 in data byte 0 of the I²C data stream. Refer to *Table 6* for more details.

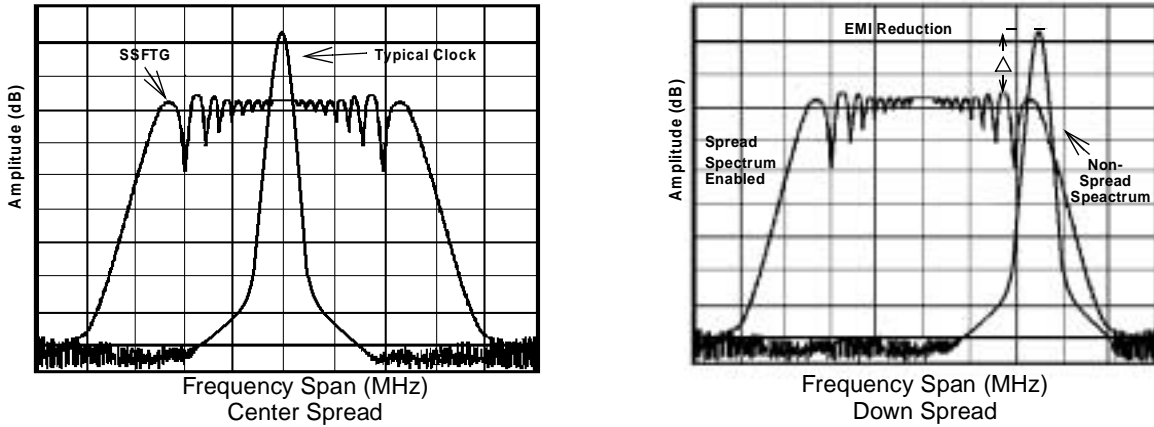

Figure 3. Clock Harmonic with and without SSCG Modulation Frequency Domain Representation

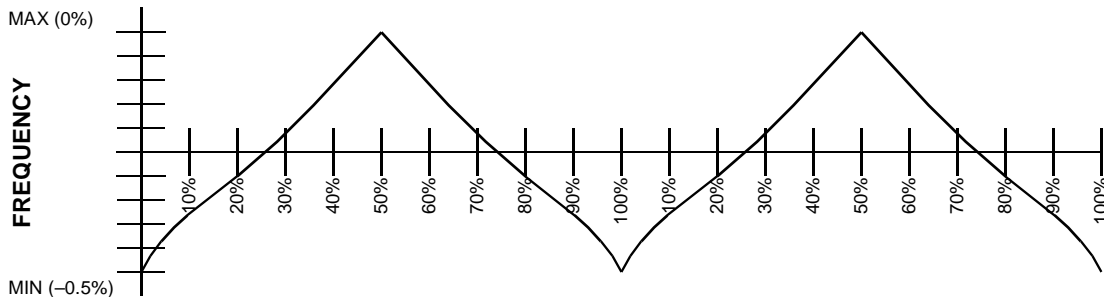

Figure 4. Typical Modulation Profile

Serial Data Interface

The W230 features a two-pin, serial data interface that can be used to configure internal register settings that control particular device functions. Upon power-up, the W230 initializes with default register settings, therefore the use of this serial data interface is optional. The serial interface is write-only (to the clock chip) and is the dedicated function of device pins SDATA and SCLOCK. In motherboard applications, SDATA and SCLOCK are typically driven by two logic outputs of the

chipset. Clock device register changes are normally made upon system initialization, if any are required. The interface can also be used during system operation for power management functions. *Table 3* summarizes the control functions of the serial data interface.

Operation

Data is written to the W230 in eleven bytes of eight bits each. Bytes are written in the order shown in *Table 4*.

Table 3. Serial Data Interface Control Functions Summary

Control Function	Description	Common Application
Clock Output Disable	Any individual clock output(s) can be disabled. Disabled outputs are actively held LOW.	Unused outputs are disabled to reduce EMI and system power. Examples are clock outputs to unused PCI slots.
CPU Clock Frequency Selection	Provides CPU/PCI frequency selections through software. Frequency is changed in a smooth and controlled fashion.	For alternate microprocessors and power management options. Smooth frequency transition allows CPU frequency change under normal system operation.
Spread Spectrum Enabling	Enables or disables spread spectrum clocking.	For EMI reduction.
Output Three-state	Puts clock output into a high impedance state.	Production PCB testing.
(Reserved)	Reserved function for future device revision or production device testing.	No user application. Register bit must be written as 0.

Table 4. Byte Writing Sequence

Byte Sequence	Byte Name	Bit Sequence	Byte Description
1	Slave Address	11010010	Commands the W230 to accept the bits in Data Bytes 0–6 for internal register configuration. Since other devices may exist on the same common serial data bus, it is necessary to have a specific slave address for each potential receiver. The slave receiver address for the W230 is 11010010. Register setting will not be made if the Slave Address is not correct (or is for an alternate slave receiver).
2	Command Code	Don't Care	Unused by the W230, therefore bit values are ignored ("don't care"). This byte must be included in the data write sequence to maintain proper byte allocation. The Command Code Byte is part of the standard serial communication protocol and may be used when writing to another addressed slave receiver on the serial data bus.
3	Byte Count	Don't Care	Unused by the W230, therefore bit values are ignored ("don't care"). This byte must be included in the data write sequence to maintain proper byte allocation. The Byte Count Byte is part of the standard serial communication protocol and may be used when writing to another addressed slave receiver on the serial data bus.
4	Data Byte 0	Refer to <i>Table 5</i>	The data bits in Data Bytes 0–7 set internal W230 registers that control device operation. The data bits are only accepted when the Address Byte bit sequence is 11010010, as noted above. For description of bit control functions, refer to <i>Table 5</i> , Data Byte Serial Configuration Map.
5	Data Byte 1		
6	Data Byte 2		
7	Data Byte 3		
8	Data Byte 4		
9	Data Byte 5		
10	Data Byte 6		
11	Data Byte 7		

Writing Data Bytes

Each bit in the data bytes controls a particular device function except for the “reserved” bits, which must be written as a logic 0. Bits are written MSB (most significant bit) first, which is bit

7. Table 5 gives the bit formats for registers located in Data Bytes 0–7.

Table 6 details additional frequency selections that are available through the serial data interface.

Table 5. Data Bytes 0–7 Serial Configuration Map

Bit(s)	Affected Pin		Control Function	Bit Control		Default
	Pin No.	Pin Name		0	1	
Data Byte 0						
7	--	--	(Reserved)	--	--	0
6	--	--	SEL_2	See Table 6		0
5	--	--	SEL_1	See Table 6		0
4	--	--	SEL_0	See Table 6		0
3	--	--	Hardware/Software Frequency Select	Hardware	Software	0
2	--	--	SEL_4	See Table 6		1
1	--	--	SEL_3	See Table 6		0
0	--	--		Normal	Three-stated	0
Data Byte 1						
7	--	--	(Reserved)	--	--	0
6	--	--	(Reserved)	--	--	0
5	--	--	(Reserved)	--	--	0
4	--	--	(Reserved)	--	--	0
3	40	SDRAM_12	Clock Output Disable	Low	Active	1
2	--	--	(Reserved)	--	--	0
1	43, 44	CPUT0, CPUC0	Clock Output Disable	Low, Three-state	Active	1
0	46	CPUT_CS	Clock Output Disable	Low	Active	1
Data Byte 2						
7	--	--	(Reserved)	--	--	0
6	7	PCI0	Clock Output Disable	Low	Active	1
5	--	--	(Reserved)	--	--	0
4	13	PCI5	Clock Output Disable	Low	Active	1
3	12	PCI4	Clock Output Disable	Low	Active	1
2	11	PCI3	Clock Output Disable	Low	Active	1
1	10	PCI2	Clock Output Disable	Low	Active	1
0	8	PCI1	Clock Output Disable	Low	Active	1
Data Byte 3						
7	--	--	(Reserved)	--	--	0
6	--	SEL_48MHz	SEL 48MHz as the output frequency for 24_48MHz	24-MHz	48-MHz	0
5	26	48MHz	Clock Output Disable	Low	Active	1
4	25	24_48MHz	Clock Output Disable	Low	Active	1
3	--	--	(Reserved)	--	--	0
2	21, 20, 18, 17	SDRAM8:11	Clock Output Disable	Low	Active	1

Table 5. Data Bytes 0–7 Serial Configuration Map (continued)

Bit(s)	Affected Pin		Control Function	Bit Control		Default
	Pin No.	Pin Name		0	1	
1	32, 31, 29, 28	SDRAM4:7	Clock Output Disable	Low	Active	1
0	38, 37, 35, 34	SDRAM0:3	Clock Output Disable	Low	Active	1
Data Byte 4						
7	--	--	(Reserved)	--	--	0
6	--	--	(Reserved)	--	--	0
5	--	--	(Reserved)	--	--	0
4	--	--	(Reserved)	--	--	0
3	--	--	(Reserved)	--	--	0
2	--	--	(Reserved)	--	--	0
1	--	--	(Reserved)	--	--	0
0	--	--	(Reserved)	--	--	0
Data Byte 5						
7	--	--	(Reserved)	--	--	0
6	--	--	(Reserved)	--	--	0
5	--	--	(Reserved)	--	--	0
4	--	--	(Reserved)	--	--	1
3	--	--	(Reserved)	--	--	0
2	--	--	(Reserved)	--	--	0
1	48	REF1	Clock Output Disable	Low	Active	1
0	2	REF0	Clock Output Disable	Low	Active	1
Data Byte 6						
7	--	--	(Reserved)	--	--	0
6	--	--	(Reserved)	--	--	0
5	--	--	(Reserved)	--	--	0
4	--	--	(Reserved)	--	--	0
3	--	--	(Reserved)	--	--	0
2	--	--	(Reserved)	--	--	0
1	--	--	(Reserved)	--	--	0
0	--	--	(Reserved)	--	--	0
Data Byte 7						
7	--	--	(Reserved)	--	--	0
6	--	--	(Reserved)	--	--	0
5	--	--	(Reserved)	--	--	0
4	--	--	(Reserved)	--	--	0
3	--	--	(Reserved)	--	--	0
2	--	--	(Reserved)	--	--	0
1	--	--	(Reserved)	--	--	0
0	--	--	(Reserved)	--	--	0

Table 6. Additional Frequency Selections through Serial Data Interface Data Bytes

Input Conditions					Output Frequency		
Data Byte 0, Bit 3 = 1					CPU	PCI	Spread Spectrum
Bit 2 SEL_4	Bit 1 SEL_3	Bit 6 SEL_2	Bit 5 SEL_1	Bit 4 SEL_0			
1	1	1	1	1	100.0	33.3	-0.5%
1	1	1	1	0	100.0	33.3	±0.25%
1	1	1	0	1	100.0	33.3	±0.5%
1	1	1	0	0	95.0	31.7	OFF
1	1	0	1	1	133.3	33.3	-0.5%
1	1	0	1	0	133.3	33.3	±0.25%
1	1	0	0	1	133.3	33.3	±0.5%
1	1	0	0	0	102.0	34.0	OFF
1	0	1	1	1	104.0	34.6	OFF
1	0	1	1	0	106.0	35.3	OFF
1	0	1	0	1	107.0	35.6	OFF
1	0	1	0	0	108.0	36.0	OFF
1	0	0	1	1	109.0	36.3	OFF
1	0	0	1	0	110.0	36.6	OFF
1	0	0	0	1	111.0	37.0	OFF
1	0	0	0	0	112.0	37.3	OFF
0	1	1	1	1	113.0	37.6	OFF
0	1	1	1	0	114.0	38.0	OFF
0	1	1	0	1	115.0	38.3	OFF
0	1	1	0	0	116.0	38.6	OFF
0	1	0	1	1	118.0	39.3	OFF
0	1	0	1	0	120.0	40.0	OFF
0	1	0	0	1	124.0	31.0	OFF
0	1	0	0	0	127.0	31.7	OFF
0	0	1	1	1	130.0	32.5	OFF
0	0	1	1	0	136.0	34.0	OFF
0	0	1	0	1	140.0	35.0	OFF
0	0	1	0	0	145.0	36.2	OFF
0	0	0	1	1	150.0	37.5	OFF
0	0	0	1	0	155.0	38.7	OFF
0	0	0	0	1	160.0	40	OFF
0	0	0	0	0	166.0	41.6	OFF

Absolute Maximum Ratings

Stresses greater than those listed in this table may cause permanent damage to the device. These represent a stress rating only. Operation of the device at these or any other conditions

above those specified in the operating sections of this specification is not implied. Maximum conditions for extended periods may affect reliability.

Parameter	Description	Rating	Unit
V_{DD}, V_{IN}	Voltage on any pin with respect to GND	-0.5 to +7.0	V
T_{STG}	Storage Temperature	-65 to +150	°C
T_B	Ambient Temperature under Bias	-55 to +125	°C
T_A	Operating Temperature	0 to +70	°C
ESD_{PROT}	Input ESD Protection	2 (min.)	kV

DC Electrical Characteristics: $T_A = 0^\circ\text{C}$ to $+70^\circ\text{C}$, $V_{DDQ3} = 3.3\text{V} \pm 5\%$

Parameter	Description	Test Condition	Min.	Typ.	Max.	Unit
Supply Current						
I_{DD}	3.3V Supply Current	CPU0, CPUC0, CPU_CS = 100 MHz Outputs Loaded ^[2]		260		mA
I_{DD}	2.5V Supply Current	CPU0, CPUC0, CPU_CS = 100 MHz Outputs Loaded ^[2]		25		mA
Logic Inputs						
V_{IL}	Input Low Voltage		GND - 0.3		0.8	V
V_{IH}	Input High Voltage		2.0		$V_{DD} + 0.3$	V
I_{IL}	Input Low Current ^[3]				-25	μA
I_{IH}	Input High Current ^[3]				10	μA
Clock Outputs						
V_{OL}	Output Low Voltage	$I_{OL} = 1$ mA			50	mV
V_{OH}	Output High Voltage	$I_{OH} = -1$ mA	3.1			V
V_{OL}	Output Low Voltage	CPU0_CS, CPU0, CPUC0 Termination to V pull-up (external)	0		0.3	V
V_{OH}	Output High Voltage	CPU0_CS, CPU0, CPUC0 Termination to V pull-up (external)	1.0		1.2	V
I_{OL}	Output Low Current	PCI0:5 $V_{OL} = 1.5\text{V}$	20.5	53	139	mA
		REF0:1 $V_{OL} = 1.5\text{V}$	25	37	76	mA
		48 MHz $V_{OL} = 1.5\text{V}$	25	37	76	mA
		24 MHz $V_{OL} = 1.5\text{V}$	25	37	76	mA
I_{OH}	Output High Current	PCI0:5 $V_{OH} = 1.5\text{V}$	31	55	139	mA
		REF0:1 $V_{OH} = 1.5\text{V}$	27	44	94	mA
		48 MHz $V_{OH} = 1.5\text{V}$	27	44	94	mA
		24 MHz $V_{OH} = 1.5\text{V}$	25	37	76	mA

Notes:

- All clock outputs loaded with 6" 60Ω transmission lines with 20-pF capacitors.
- W230 logic inputs (except FS3) have internal pull-up devices (pull-ups not full CMOS level). Logic input FS3 has an internal pull-down device.

DC Electrical Characteristics: $T_A = 0^\circ\text{C to } +70^\circ\text{C}$, $V_{DDQ3} = 3.3\text{V}\pm 5\%$

Parameter	Description	Test Condition	Min.	Typ.	Max.	Unit
Crystal Oscillator						
V_{TH}	X1 Input Threshold Voltage ^[4]	$V_{DDQ3} = 3.3\text{V}$		1.65		V
C_{LOAD}	Load Capacitance, Imposed on External Crystal ^[5]			14		pF
$C_{IN,X1}$	X1 Input Capacitance ^[6]	Pin X2 unconnected		28		pF
Pin Capacitance/Inductance						
C_{IN}	Input Pin Capacitance	Except X1 and X2			5	pF
C_{OUT}	Output Pin Capacitance				6	pF
L_{IN}	Input Pin Inductance				7	nH

AC Electrical Characteristics
 $T_A = 0^\circ\text{C to } +70^\circ\text{C}$, $V_{DDQ3} = 3.3\text{V}\pm 5\%$, $f_{XTL} = 14.31818\text{ MHz}$

AC clock parameters are tested and guaranteed over stated operating conditions using the stated lump capacitive load at the clock output; Spread Spectrum is disabled.

CPU Clock Outputs (CPUT0, CPUC0, CPUT_CS)^[7]

Parameter	Description	Test Condition/Comments	CPU = 100 MHz			CPU = 133 MHz			Unit
			Min.	Typ.	Max.	Min.	Typ.	Max.	
t_R	Output Rise Edge Rate			1.0			1.0		V/ns
t_F	Output Fall Edge Rate			1.0			1.0		V/ns
t_D	Duty Cycle	Measured at 50% point	45		55	45		55	%
t_{JC}	Jitter, Cycle to Cycle				250			250	ps
t_{SK}	Output Skew	Measured on rising edge at 1.25V		TBD			TBD		ps
f_{ST}	Frequency Stabilization from Power-up (cold start)	Assumes full supply voltage reached within 1 ms from power-up. Short cycles exist prior to frequency stabilization.			3			3	ms
Z_o	AC Output Impedance	$V_O = V_X$		50			50		Ω

Notes:

- X1 input threshold voltage (typical) is $V_{DD}/2$.
- The W230 contains an internal crystal load capacitor between pin X1 and ground and another between pin X2 and ground. Total load placed on crystal is 14 pF; this includes typical stray capacitance of short PCB traces to crystal.
- X1 input capacitance is applicable when driving X1 with an external clock source (X2 is left unconnected).
- Refer to *Figure 5* for K7 operation clock driver test circuit.

PCI Clock Outputs, PCI0:5 (Lump Capacitance Test Load = 30 pF)

Parameter	Description	Test Condition/Comments	Min.	Typ.	Max.	Unit
t_P	Period	Measured on rising edge at 1.5V	30			ns
t_H	High Time	Duration of clock cycle above 2.4V	12			ns
t_L	Low Time	Duration of clock cycle below 0.4V	12			ns
t_R	Output Rise Edge Rate	Measured from 0.4V to 2.4V	1		4	V/ns
t_F	Output Fall Edge Rate	Measured from 2.4V to 0.4V	1		4	V/ns
t_D	Duty Cycle	Measured on rising and falling edge at 1.5V	45		55	%
t_{JC}	Jitter, Cycle-to-Cycle	Measured on rising edge at 1.5V. Maximum difference of cycle time between two adjacent cycles.			250	ps
t_{SK}	Output Skew	Measured on rising edge at 1.5V			500	ps
t_O	CPU to PCI Clock Skew	Covers all CPU/PCI outputs. Measured on rising edge at 1.5V. CPU leads PCI output.	1.5		4	ns
f_{ST}	Frequency Stabilization from Power-up (cold start)	Assumes full supply voltage reached within 1 ms from power-up. Short cycles exist prior to frequency stabilization.				ms
Z_O	AC Output Impedance	Average value during switching transition. Used for determining series termination value.		30		Ω

REF0:1 Clock Outputs (Lump Capacitance Test Load = 20 pF)

Parameter	Description	Test Condition/Comments	Min.	Typ.	Max.	Unit
f	Frequency, Actual	Frequency generated by crystal oscillator	14.318			MHz
t_R	Output Rise Edge Rate	Measured from 0.4V to 2.4V	0.5		2	V/ns
t_F	Output Fall Edge Rate	Measured from 2.4V to 0.4V	0.5		2	V/ns
t_D	Duty Cycle	Measured on rising and falling edge at 1.5V	45		55	%
f_{ST}	Frequency Stabilization from Power-up (cold start)	Assumes full supply voltage reached within 1 ms from power-up. Short cycles exist prior to frequency stabilization.			3	ms
Z_O	AC Output Impedance	Average value during switching transition. Used for determining series termination value.		40		Ω

48-MHz Clock Output (Lump Capacitance Test Load = 20 pF)

Parameter	Description	Test Condition/Comments	Min.	Typ.	Max.	Unit
f	Frequency, Actual	Determined by PLL divider ratio (see m/n below)	48.008			MHz
f_D	Deviation from 48 MHz	$(48.008 - 48)/48$	+167			ppm
m/n	PLL Ratio	$(14.31818 \text{ MHz} \times 57/17 = 48.008 \text{ MHz})$	57/17			
t_R	Output Rise Edge Rate	Measured from 0.4V to 2.4V	0.5		2	V/ns
t_F	Output Fall Edge Rate	Measured from 2.4V to 0.4V	0.5		2	V/ns
t_D	Duty Cycle	Measured on rising and falling edge at 1.5V	45		55	%
f_{ST}	Frequency Stabilization from Power-up (cold start)	Assumes full supply voltage reached within 1 ms from power-up. Short cycles exist prior to frequency stabilization.			3	ms
Z_O	AC Output Impedance	Average value during switching transition. Used for determining series termination value.		40		Ω

24-MHz Clock Output (Lump Capacitance Test Load = 20 pF)

Parameter	Description	Test Condition/Comments	Min.	Typ.	Max.	Unit
f	Frequency, Actual	Determined by PLL divider ratio (see m/n below)	24.004			MHz
f _D	Deviation from 24 MHz	(24.004 – 24)/24	+167			ppm
m/n	PLL Ratio	(14.31818 MHz x 57/34 = 24.004 MHz)	57/34			
t _R	Output Rise Edge Rate	Measured from 0.4V to 2.4V	0.5		2	V/ns
t _F	Output Fall Edge Rate	Measured from 2.4V to 0.4V	0.5		2	V/ns
t _D	Duty Cycle	Measured on rising and falling edge at 1.5V	45		55	%
f _{ST}	Frequency Stabilization from Power-up (cold start)	Assumes full supply voltage reached within 1 ms from power-up. Short cycles exist prior to frequency stabilization.			3	ms
Z _O	AC Output Impedance	Average value during switching transition. Used for determining series termination value.		40		Ω

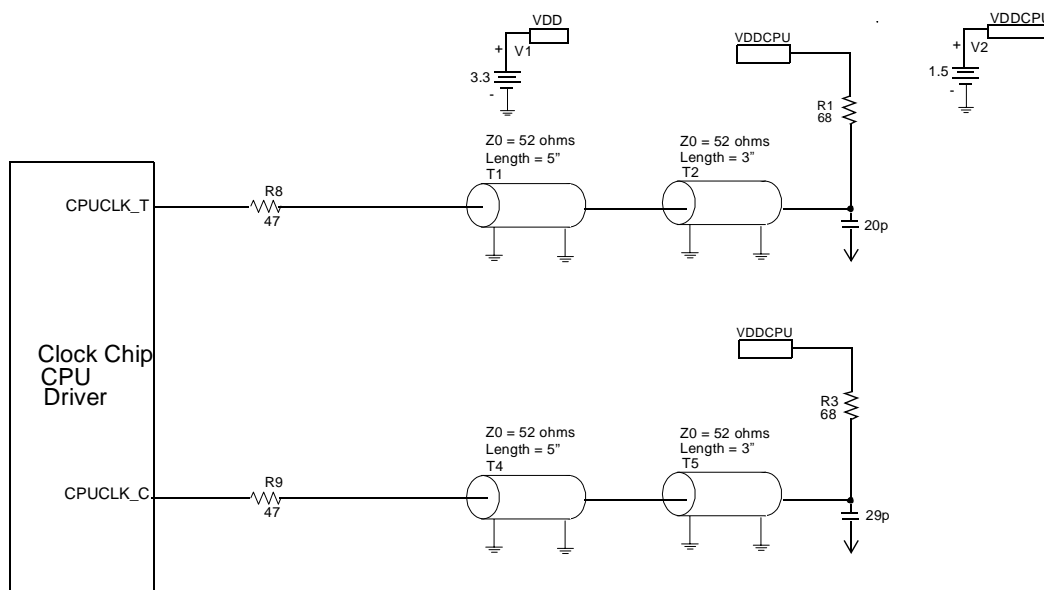
Figure 5. K7 Open Drain Clock Driver Test Circuit
Ordering Information

Ordering Code	Package Name	Package Type
W230	H	48-pin SSOP (300 mils)

Document #: 38-00890-**

Layout Diagram

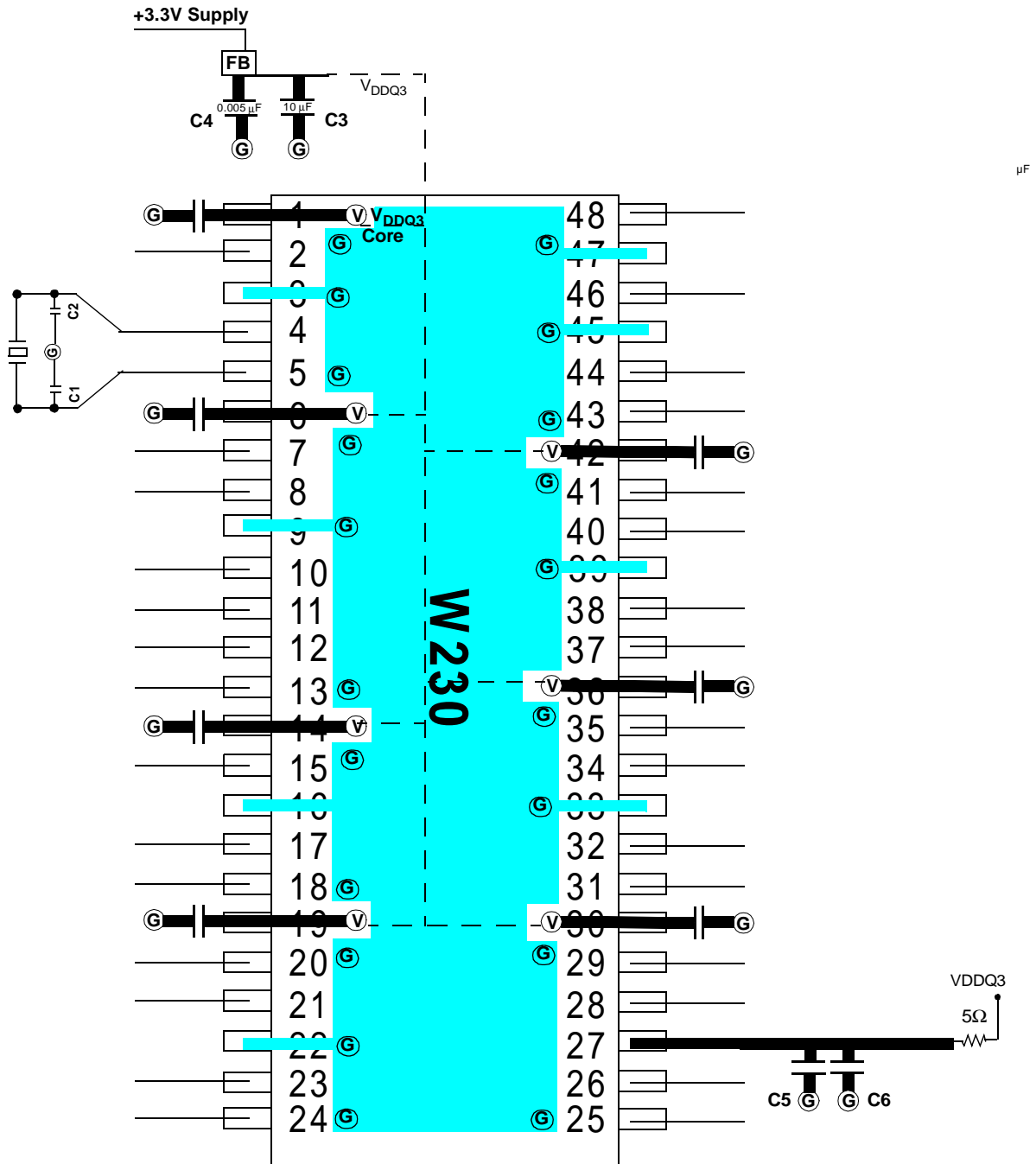

FB = Dale ILB1206 - 300 (300Ω @ 100 MHz)

C1 & C3 = 10–22 μF C2 & C4 = 0.005 μF C5 = 47 μF C6 = 0.1 μF

Ⓞ = VIA to GND plane layer Ⓟ = VIA to respective supply plane layer

Note: Each supply plane or strip should have a ferrite bead and capacitors

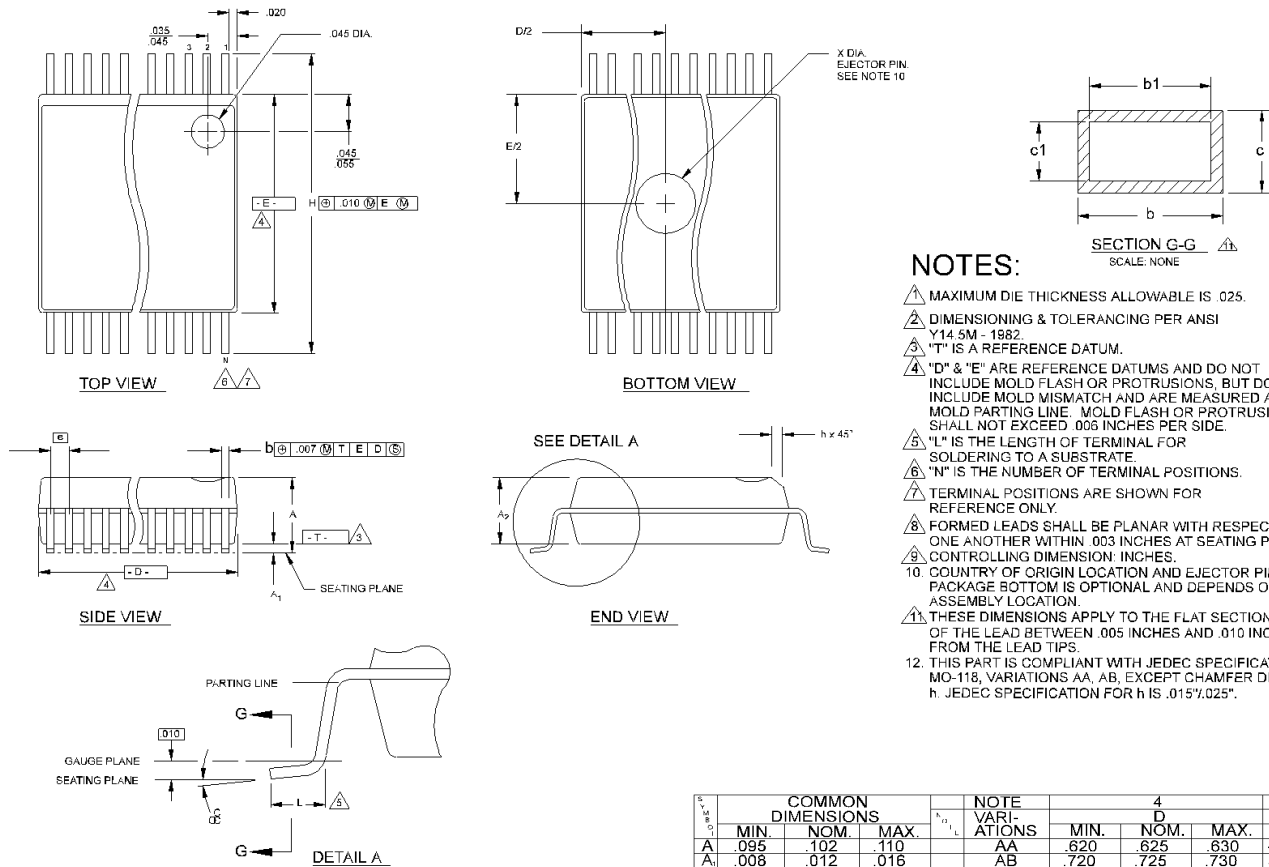
Package Diagram
48-Pin Small Shrink Outline Package (SSOP, 300 mils)

NOTES:

1. MAXIMUM DIE THICKNESS ALLOWABLE IS .025.
2. DIMENSIONING & TOLERANCING PER ANSI Y14.5M - 1982.
3. "T" IS A REFERENCE DATUM.
4. "D" & "E" ARE REFERENCE DATUMS AND DO NOT INCLUDE MOLD FLASH OR PROTRUSIONS, BUT DOES INCLUDE MOLD MISMATCH AND ARE MEASURED AT THE MOLD PARTING LINE. MOLD FLASH OR PROTRUSIONS SHALL NOT EXCEED .006 INCHES PER SIDE.
5. "L" IS THE LENGTH OF TERMINAL FOR SOLDERING TO A SUBSTRATE.
6. "N" IS THE NUMBER OF TERMINAL POSITIONS.
7. TERMINAL POSITIONS ARE SHOWN FOR REFERENCE ONLY.
8. FORMED LEADS SHALL BE PLANAR WITH RESPECT TO ONE ANOTHER WITHIN .003 INCHES AT SEATING PLANE.
9. CONTROLLING DIMENSION: INCHES.
10. COUNTRY OF ORIGIN LOCATION AND EJECTOR PIN ON PACKAGE BOTTOM IS OPTIONAL AND DEPENDS ON ASSEMBLY LOCATION.
11. THESE DIMENSIONS APPLY TO THE FLAT SECTION OF THE LEAD BETWEEN .005 INCHES AND .010 INCHES FROM THE LEAD TIPS.
12. THIS PART IS COMPLIANT WITH JEDEC SPECIFICATION MO-118, VARIATIONS AA, AB, EXCEPT CHAMFER DIMENSION h. JEDEC SPECIFICATION FOR h IS .015".025".

Summary of nominal dimensions in inches:

Body Width: 0.296
Lead Pitch: 0.025
Body Length: 0.625
Body Height: 0.102

DIMENSION	COMMON DIMENSIONS			NOTE VARIATIONS	4 D			6 N
	MIN.	NOM.	MAX.		MIN.	NOM.	MAX.	
A	.095	.102	.110					
A ₁	.008	.012	.016	AA	.620	.625	.630	48
A ₂	.088	.090	.092	AB	.720	.725	.730	56
b	.008	.010	.0135					
b ₁	.008	.010	.012					
c	.005	-	.010					
c ₁	.005	.006	.0085					
D	SEE VARIATIONS			4				
E	.292	.296	.299					
e		.025 BSC						
H	.400	.406	.410					
h	.010	.013	.016					
L	.024	.032	.040					
N	SEE VARIATIONS			6				
X	.085	.093	.100	10				
α	0°	5°	8°					

THIS TABLE IN INCHES

DIMENSION	COMMON DIMENSIONS			NOTE VARIATIONS	4 D			6 N
	MIN.	NOM.	MAX.		MIN.	NOM.	MAX.	
A	2.41	2.59	2.79					
A ₁	0.20	0.31	0.41	AA	15.75	15.88	16.00	48
A ₂	2.24	2.29	2.34	AB	18.29	18.42	18.54	56
b	0.203	0.254	0.343					
b ₁	0.203	0.254	0.305					
c	0.127	-	0.254					
c ₁	0.127	0.152	0.216					
D	SEE VARIATIONS			4				
E	7.42	7.52	7.59					
e		0.635 BSC						
H	10.16	10.31	10.41					
h	0.25	0.33	0.41					
L	0.61	0.81	1.02					
N	SEE VARIATIONS			6				
X	2.16	2.36	2.54	10				
α	0°	5°	8°					

THIS TABLE IN MILLIMETERS