

MPEG-4 Decoder for Set-top, DVD and Streaming Applications

Description

The EM847x family is a single-chip MPEG audio/video decoder that supports DVD-Video, Superbit™ DVD, SVCD, VCD and audio CD media formats. Video decoding support includes MPEG-1, MPEG-2 MP@ML and MPEG-4 advanced simple video profile Level 5¹. Audio decoding support includes Dolby® Digital, MPEG-1 Layers 1 and 2, MPEG-4 high quality profile Level 2, and 16-bit linear PCM. DVD-Video support includes hardware CSS decryption, 16:9 and 4:3 aspect ratios, letterboxing, 3:2 pull-down, multiple angles and sub-picture.

Based on the company's award-winning REALmagic® Video Streaming Technology, the EM847x family provides highly-integrated solutions for high-quality decoding of MPEG-1, MPEG-2 and MPEG-4. Positioned as a cost-effective solution for streaming video clients, advanced digital set-top boxes and next-generation interactive DVD players, the EM847x enables manufacturers to easily incorporate streaming video, progressive DVD playback and video-on-demand into their products.

Common Features

- Pin and functionally compatible with EM8400 (EM8470 and EM8471 only)
- Compatible with MPEG-4 Client Players from Envivio and iVAST and a wide variety of MPEG-2 video servers
- Supports ISMA and MPEG-2 streaming formats, IP multicasting
- Supports DVD-Video, Superbit DVD, SVCD, VCD, audio CD media formats
- MPEG-1, MPEG-2 MP@ML, MPEG-4 Advanced Simple Profile Level 5¹ video decoding
- Dolby Digital, MPEG-1 Layers 1 and 2, MPEG-4 High Quality Profile Level 2, and linear PCM audio decoding

Block Diagram

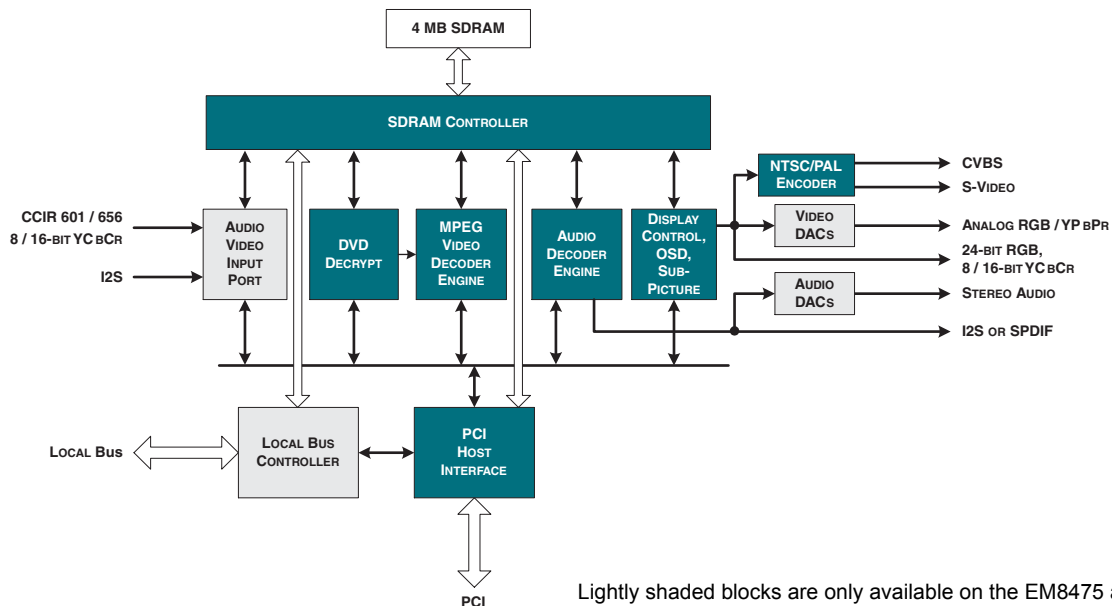

Lightly shaded blocks are only available on the EM8475 and EM8476

¹Without 1/4 pixel and global motion compensation

Bitstream Demultiplexing

The host processor performs MPEG-4 file demultiplexing and system decoding (except audio and video decoding), MPEG-2 transport and program stream and MPEG-1 system stream demultiplexing. The EM847x operates as a PCI bus master while audio and video elementary streams are transferred from host system memory to EM847x memory by the EM847x's DMA engine.

Software drivers for the x86, available from Sigma Designs, include MPEG-4 audio decode, MPEG-2 transport and program stream demultiplex, MPEG-1 system stream demultiplex and DVD-Video/SVCD/VCD stream demultiplex and navigation. Supported operating systems for our x86-based reference designs include Windows® XP Embedded, Windows CE .NET and Linux. For other operating systems and hardware platforms, our Professional Services Group can assist in supporting your requirements.

DVD-Video Decryption

The EM847x includes decryption logic and supports DVD-Video CSS procedural specifications. It also fully supports DVD-Video control features including up to 8 language sound tracks, 32 subtitle settings, letterbox, pan and scan, multi-angles and 3:2 pull-down.

MPEG Video Decoding

The MPEG video decoder engine contains the following modules used for MPEG-1, MPEG-2 and MPEG-4 video decoding:

- MPEG-1 & 2 Huffman Decoder
- MPEG-4 Huffman Decoder
- Motion Compensation
- IDCT
- Inverse Quantizer
- AC / DC Predictor

The Huffman Decoder receives bitstream data from DRAM and works in collaboration with the internal RISC processor to decode bitstream elements down to the block level. It then decodes transformed coefficients and sends them to the Inverse Quantizer. The Inverse Quantizer mainly performs two consecutive multiplications on the transformed coefficients (quantizer scale and quantizer matrix) and sends them to the IDCT. The IDCT converts them into pixels (or pixel differences for non-intra pictures), which are sent to the Motion Compensation block. The Motion Compensation block loads decoded macroblocks from DRAM (for prediction), adds the pixel differences and stores the result back to DRAM.

Common Features

- Programmable display output with improved scaling up to 1920x1080 resolution, interlaced or progressive, up to 120 Hz refresh
- 2-, 4-, 7- or 8-bit OSD with optional run-length compression, alpha blending and flicker filtering
- 80 MHz digital video output interface: 8- or 16-bit CCIR 601 / 656 YCbCr
- Improved NTSC/PAL composite and s-video outputs with optional Macrovision v7.1 protection and VBI data support (10-bit DACs)
- Digital audio output interface: I2S for PCM or S/PDIF (IEC 60958) for PCM, compressed Dolby Digital and compressed DTS
- Improved PCI v2.1 bus master / slave interface supports both read and write operations
- 2.5V core with 3.3V I/O (5V tolerant) for low power operation
- Package: 208 PQFP for EM8470 and EM8471 (pin compatible with EM8400), 328 BGA for EM8475 and EM8476

EM8475 / EM8476 Features

- Digital audio input interface: I2S
- 80 MHz digital video input interface: 8- or 16-bit CCIR 601 / 656 YCbCr supporting resolutions up to 1920x1080i
- 80 MHz 24-bit digital RGB output interface for DVI with HDCP support
- Interlaced or progressive analog RGB or YPbPr video outputs with optional Macrovision AGC v1.03 protection and VBI data support (10-bit DACs)
- Stereo audio DACs
- Flexible Local Bus interface

Applications

- Consumer products needing PVR and playback of video-on-demand (VOD), streaming video, progressive DVD
- Set-top boxes, media/home gateways, video end points, convergence appliances

MPEG-1 and MPEG-2 Huffman Decoder

The MPEG Video Decoder engine uses the Huffman Decoder as its front end. It can decode either a MPEG-1 or MPEG-2 formatted data stream. The Huffman Decoder is commanded directly from the RISC processor. It extracts fixed-length, variable-length or start codes from the bitstream and returns the value to the RISC processor or passes it directly to the Inverse Quantizer. The Huffman Decoder can also do tasks such as decode the macroblock increment address, get the macroblock type, get coded block pattern, get motion vector codes and decode a delta motion vector.

MPEG-4 Huffman Decoder

The MPEG-4 Huffman Decoder is the front-end to the MPEG-4 engine. It provides specialized instructions to the RISC processor to enable the decoding of Simple Profile MPEG-4 streams. These instructions are of three different kinds: get or view a fixed-length bit field, get an individual variable length code and get the DCT coefficients for the whole macroblock. Additionally, the Huffman Decoder provides support for the error-resiliency features of MPEG-4. It can be used to read data-partitioned Video Object Planes, with or without Reversible Variable Length Codes (RVLCs). It cannot, however, read RVLCs backwards.

AC/DC Predictor

If the input stream is MPEG-1 or MPEG-2, the AC/DC predictor passes through. Otherwise, it receives data from the zig-zag through a 19-bit stream interface. A predictor is added to the incoming AC/DC coefficients. The result is saturated and output to the inverse quantizer through a similar interface. This result will also be used as future predictors. For prediction, this block must save an entire macroblock line of informations. This module supports MPEG-4 simple profile.

Inverse Quantizer

The Inverse Quantizer block resides between the AC/DC predictor block and the inverse DCT block. Its primary function is to receive coefficients from the AC/DC predictor, scale them and send them to the IDCT. It supports the MPEG-1, MPEG-2 MP@ML and MPEG-4 simple profile.

Inverse DCT

The IDCT (Inverse Discrete Cosine Transform) module is a hardware implementation of the DCT/IDCT of an 8x8 pixel block used in MPEG compression/ decompression. The DCT transforms a block of 8x8 pixels into a block of 8x8 transformed coefficients. The IDCT transforms a block of 8x8 transformed coefficients back into a block of 8x8 pixels.

Video Decoder Block Diagram

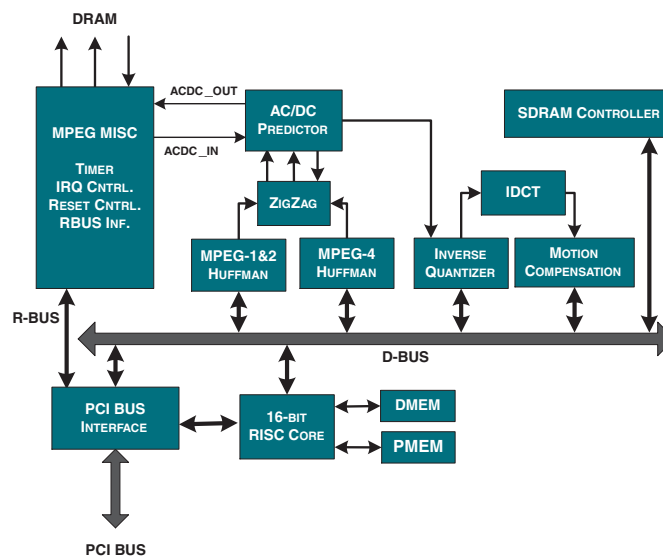

Motion Compensation Module

The Motion Compensation Module performs all the motion compensation tasks required to decode MPEG-1, MPEG-2 and MPEG-4 bitstreams. This includes predicting the image block for the picture being decoded, using pixels from previously decoded pictures.

Audio Input and Output Interfaces

The audio decoding block supports the following audio bit-stream formats:

- Dolby Digital with conformance to Group A (20-bit)
- MPEG-1 Layers 1 and 2
- MPEG-4 CELP and Low Complexity AAC (decoded using software on x86 host CPU)
- 16-bit linear PCM data
- Compressed Dolby Digital and DTS[®] digital output via S/PDIF

I2S Digital Audio Output

The I2S serial audio output block receives either the 2-channel down-mixed decoded Dolby Digital audio, decoded MPEG-1 audio, decoded MPEG-4 audio or PCM audio data. It then converts this data into a serial bitstream compatible with the I2S specification. The $256 \times F_s$ serial clock is generated by an internal digital PLL or an external clock source may be used.

S/PDIF Digital Audio Output

In addition to receiving the same audio data as the I2S digital audio output block, the S/PDIF output block can receive compressed DTS and compressed Dolby Digital audio data. It then converts this data into a serial bitstream compatible with the S/PDIF specification.

Analog Stereo Audio Output

The EM8475 and EM8476 include two on-chip audio DACs that receive the same 2-channel information as the I2S digital output and convert it to analog.

I2S Digital Audio Input

The EM8475 and EM8476 also support an I2S digital audio input. This audio data may be output onto the I2S or S/PDIF outputs.

Video Display Controller

The display controller reads picture data from DRAM and displays it with proper format, timing and synchronization signals. This is a real-time process driven by the video clock.

The display controller operates in one of four modes:

- Master mode -- the display controller generates HSYNC and VSYNC from an internal or external video clock up to 80 MHz
- Slave mode -- the display controller receives HSYNC and VSYNC from an internal or external video clock up to 80 MHz

The video display timing can be set for interlaced or non-interlaced (progressive) video output up to 120 Hz.

Sub-Pictures

Sub-pictures are compressed bit maps overlaid on decoded MPEG video which can be scrolled up and down and faded in and out. The area, content, color and contrast in every video field can be changed. These modifications produce special effects such as highlighting.

OSD (On-Screen Display)

The OSD enables simple full screen graphical menus to be displayed and blended with the MPEG decoded video and sub-picture. It supports 4 palletized color depths: 4 colors (2 bits per pixel), 16 colors (4 bits per pixel), 128 colors (7 bits per pixel) and 256 colors (8 bits per pixel). The bit map can be compressed using Run-Length Coding (RLC) in 2-, 4- and 7-bit per pixel modes. A 256x32 color look-up table (CLUT) is provided to convert the 2-, 4-, 7- or 8-bit code into a 24-bit YCbCr color and 16 levels of alpha blending. The Highlight function is supported in 2-, 4- and 7-bit per pixel modes.

The OSD supports programmable 3-line flicker filtering to improve the graphics quality on interlaced displays.

Letterbox Display

Letterbox mode provides vertical downscaling; 16:9 pictures can be displayed in a letterbox fashion on a traditional 4:3 display.

Pan and Scan Display

Pan and scan mode expands the video image to 16:9. A section of the image can be displayed at full height on a 4:3 TV display.

Alpha Blending

Alpha blending provides two layers of blending: sub-picture over the MPEG video and OSD over both the sub-picture and MPEG video. Up to 16 levels of blending are available.

Video Input and Output Interfaces

Video output ports provide digital RGB or YCbCr outputs and include an integrated NTSC/PAL video encoder and video DACs for composite, s-video and component analog outputs.

VBI Support

NTSC closed captioning on lines 21 and 284 is supported. In addition, NTSC widescreen signaling (WSS) and copy generation management (CGMS-A) on lines 20 and 283, as defined by IEC 61880, is supported. This information specifies the aspect ratio of the current program and also provides copy protection capabilities.

PAL widescreen signaling (WSS) on line 23, as defined by ETSI EN300284 and ITU-R BT.1119, is supported. This information specifies the aspect ratio of the current program.

Digital Video Output

The digital video output, controlled by the video display controller, supports 8- / 16-bit CCIR 601 / 656 4:2:2 YCbCr data. An additional 24-bit RGB output mode is supported on the EM8475 and EM8476. It may be operated as a timing master or slave at rates up to 80 MHz (160 MBps) and resolutions up to 720p or 1080i.

The 24-bit RGB output mode supports HDCP (High-bandwidth Digital Content Protection) when interfaced to a DVI transmitter chip.

TV Encoder - Composite and S-Video Output

A high-quality NTSC/PAL encoder (with optional Macrovision v7.1 protection) that supports the NTSC-M, NTSC-J, PAL-B/D/G/H/I, PAL-60 and PAL-M baseband video standards is available. It features three 10-bit video DACs to generate simultaneous composite and s-video outputs. The analog video outputs are capable of driving a doubly-terminated 75-ohm load.

Component Analog Output

The EM8475 and EM8476 also include component YPbPr or RGB analog outputs, with optional Macrovision AGC v1.03 protection in 480p YPbPr mode. This component analog output can be programmed to be either RGB or YPbPr video data, interlaced or progressive, from NTSC / PAL resolution up to 1920x1080. The analog video outputs are capable of driving a doubly-terminated 75-ohm load.

When generating analog RGB or YPbPr video, the composite video output is always present; the s-video output is not available.

Supported analog formats are:

- RGB and composite video for SCART support
- RGB with sync on green
- SMPTE GBR
- Betacam YUV
- M-II YUV
- SMPTE YPbPr

If copy protection is used during DVD-Video playback, the resolution on the EM8475 analog YPbPr / RGB outputs may not be higher than standard definition (720x480 or 720x576) unless driving a VGA monitor. If the output is configured to be progressive YPbPr, only 480p video may be generated.

Digital Video Input

The video input port, available only on the EM8475 and EM8476, is designed to capture video data in 8- / 16-bit CCIR 601 / 656 YCbCr video data formats. The capture port must operate in slave mode, synchronized to the input clock and sync signals. The capture port is designed to support video rates up to 80 MHz (160 MBps) and resolutions up to 720p or 1080i.

This input may be converted to progressive using either field merging or scan line interpolation.

Note that only one video stream can be displayed at a time - either MPEG video or input video.

Local Bus Controller Interface

The Local Bus Controller (LBC) interface, supported on the EM8475 and EM8476, is a versatile block, designed to interface the DRAM controller and PCI interface to an external device, such as a non-PCI MPEG encoder chip. The LBC is designed to handle DMA transfers (FIFO read/write from the DRAM) and single register read/write from the external device to or from the PCI interface. The same DMA transfers and register read/write operations can be done from the external device to or from the DRAM controller within the EM8475 and EM8476.

The LBC interface is compatible with the 16-bit multiplexed address / data format (Intel format), 16-bit data and 8-bit address format (generic format) and 16-bit compressed data format. It also directly supports the Stream Machine SM2210 / 2288 MPEG codecs.

PCI Host Interface

The PCI interface is the main conduit between the EM847x and the host processor. It is designed for both master reads and writes with programmable burst length and is PCI v2.1 compliant. The PCI interface supports 3.3V and 5V operation and ACPI power management from the PCI v2.2 specification.

Additional Software Available

VOD Client Software (MPEG-2)

VOD client software for the x86 is available that supports select MPEG-2 video servers, including:

- Cisco's IPTV family
- Concurrent's MediaHawk
- InfoValue's MediaQuick
- Kasenna's MediaBase
- nCUBE's NVS
- Streaming21's Media Server
- Thirdspace's OVS (Oracle Video Server)

For the latest list, please check with your local sales representative.

VOD Client Software (ISMA, RTSP)

VOD client software for the x86 is available that supports RTSP-based ISMA streaming.

IP Multicasting Client Software

IP multicasting client software for the x86 is available.

MPEG-4 Client System Software

Third party x86 client software is available that supports the EM847x, including Envivio and iVAST. For the latest list, please check with your local sales representative.

Memory Requirements

The EM847x requires a minimum of 4 MB (1Mb x 32) of 100 MHz SDRAM.

Application Example: Set-top Box with PVR, DVD-Video Playback, DVI Output

The set-top box example below supports PVR, DVD-Video playback, and DVI output capability. System integration requires very little external logic since the EM847x provides most of the features including:

- Streaming video or video-on-demand (VOD) playback
- Progressive DVD-Video playback
- Interlaced or progressive YPbPr or RGB video outputs
- NTSC / PAL composite and s-video outputs
- Analog and S/PDIF audio outputs

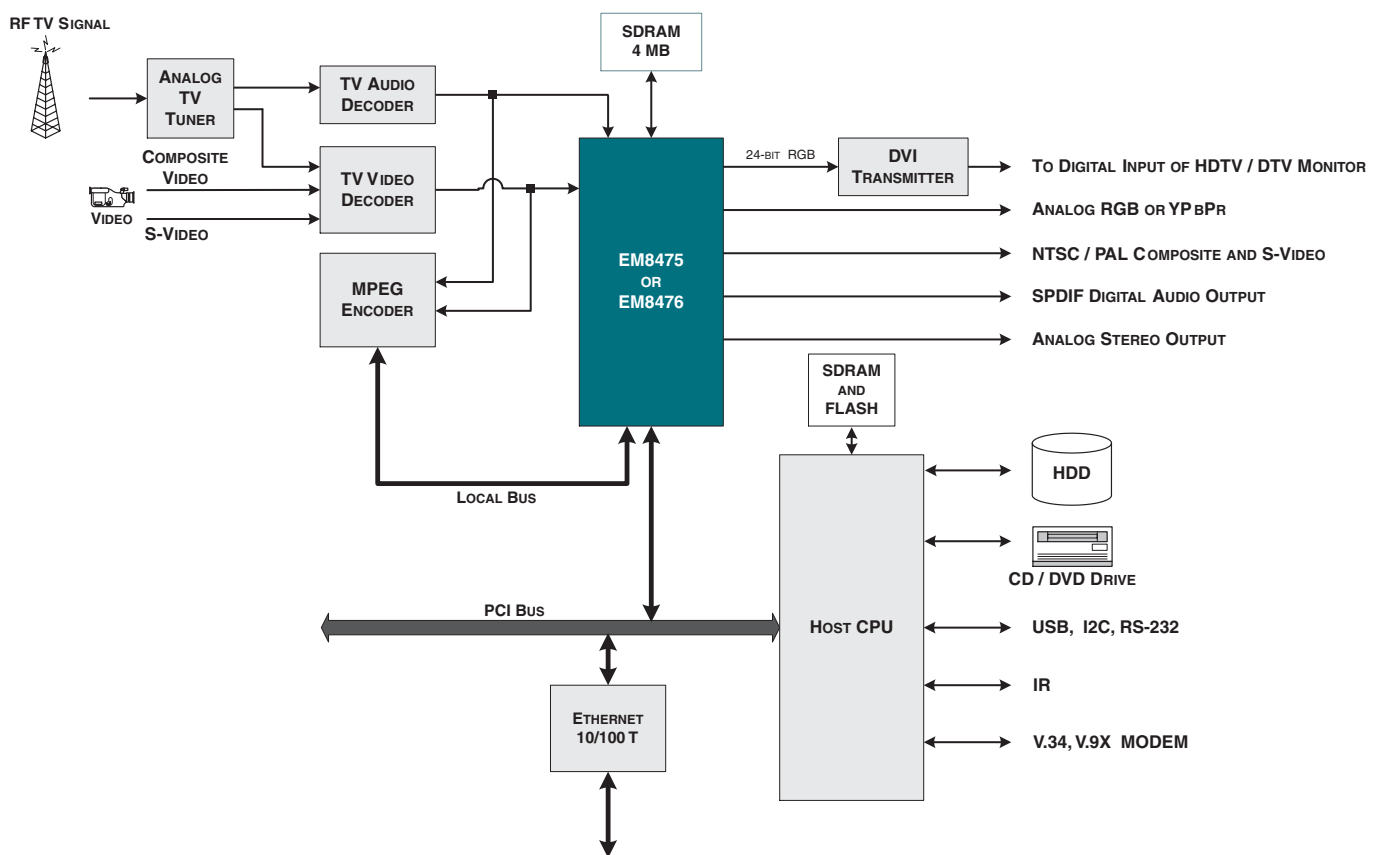

Application Example: Gateway

The home gateway example below also supports PVR and DVD-Video playback. System integration requires very little external logic since the EM847x provides most of the features including:

- Streaming video or video-on-demand (VOD) playback
- Progressive DVD-Video playback
- Analog and S/PDIF audio outputs

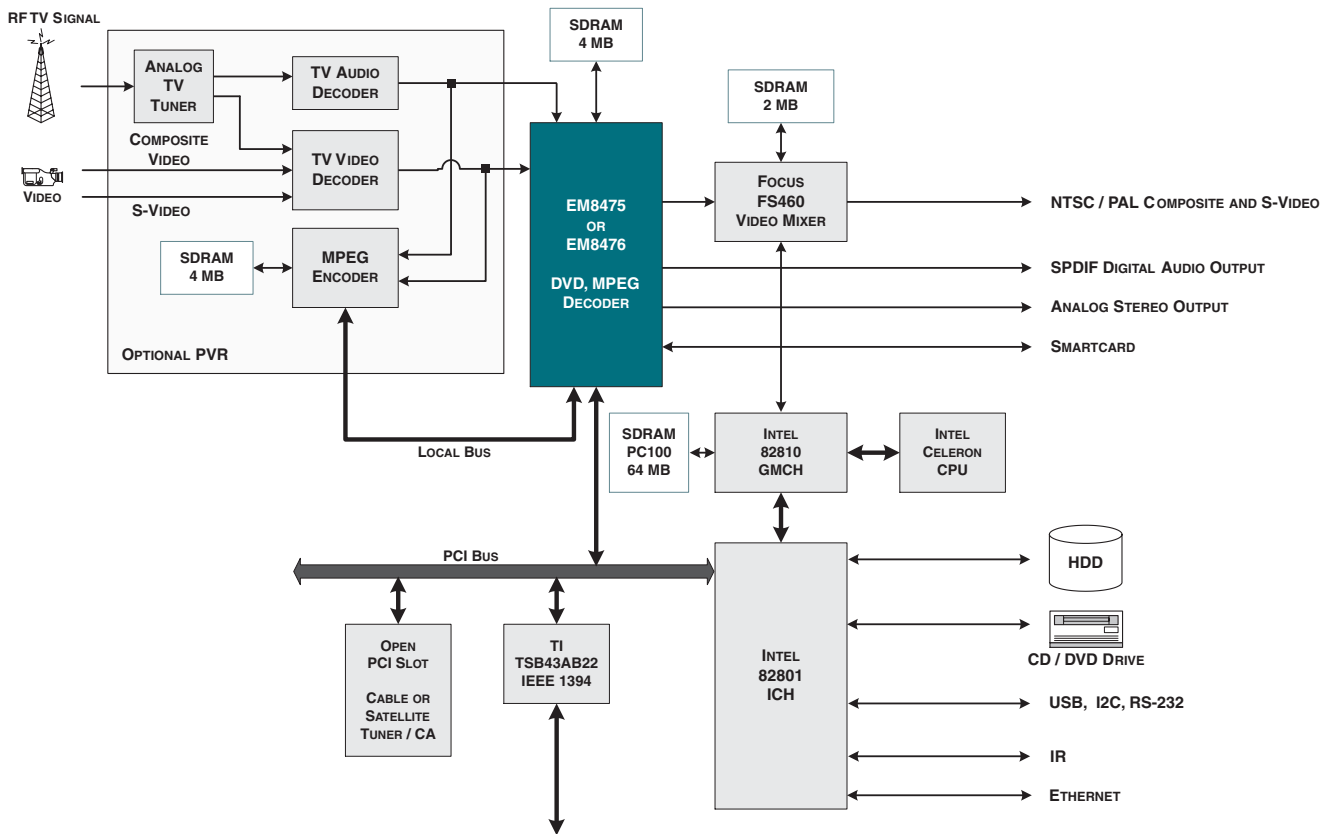

Hardware vs. Software MPEG Decoding

Use hardware-based MPEG decoding when:

- Delivery of audio and video to a television is the primary function of the system. Standard consumer-oriented connectors for audio and video must be used, instead of PC-oriented break-out cables and mini jacks. (Example: set-top box.)
- Home theater quality audio and video (such as 6-channel audio analog outputs, component YPbPr or RGB analog video outputs and a SPDIF digital audio output) are required. Although specifications for audio and video solutions for the PC market look good on paper, the products themselves rarely meet consumer expectations.
- A relatively slow CPU, such as an embedded processor, is used to lower system costs. Slower CPUs also reduce power consumption and eliminate noisy fans. Decoding full-screen MPEG-4 requires a 1 GHz CPU, which is currently far too costly for low-cost set-top boxes to employ.
- Multiple video streams must be decoded simultaneously to support picture-in-picture (PIP).
- Ancillary data processing, such as copy protection, closed captioning (multiple languages), teletext (multiple languages), v-chip (multiple regions) and widescreen signaling must be performed for each active video stream displayed. Widescreen processing must be able to handle anamorphic and letterboxed content for either 4:3 or 16:9 televisions. These are typically overlooked in software-based solutions.
- Alpha blending is required when overlaying text and graphics (such as closed captioning, teletext, EPG, OSD, etc.) over video to avoid artifacts (such as flicker) when displayed on a television. Such artifacts are caused by the limited-bandwidth video connection between the set-top box and television. It is typically implemented using anti-aliased fonts and graphics.
- High quality video scaling is required for large television screen sizes. Artifacts not noticeable on a small VGA monitor are magnified on a large television.

Use software-based MPEG decoding when:

- MPEG decoding is a secondary, rather than a primary function of the system. (Example: PC.)
- MPEG decoding is used in a single-tasking environment. Since MPEG decoding requires substantial CPU resources, using other applications usually affects playback quality.
- A fast CPU is already available on the platform.
- Only standard stereo audio and video (composite or VGA) outputs are needed.

General Specifications

Media Formats

- DVD-Video, Superbit DVD, SVCD (IEC 62107-2000), VCD 1.x, VCD 2.0, audio CD
- 15 Mbps sustained input data rate

Streaming Formats

- MPEG-2, ISMA
- 15 Mbps sustained input data rate

Video Decoding Standards

- MPEG-1, MPEG-2 MP@ML
- MPEG-4 Advanced Simple Profile Level 5¹. Rectangular shape video decoding up to CCIR 601 resolution (720x480 or 720x576), support for B pictures, data partitioning support for error resiliency, up to 4 objects decoded in CIF resolution and compositing with text and graphics.
- Error concealment
- DVD-Video and Superbit DVD
 - CSS decryption
 - 16:9 and 4:3 playback, letterbox, 3:2 pull-down
 - Multiple angles and sub-picture
 - DVD-Video navigation software

Video Processing

- Brightness, color, contrast controls
- Advanced scaling up to 1920x1080 pixels
- Interlaced or non-interlaced output up to 120 Hz
- 2-, 4-, 7- or 8-bit OSD with optional run-length compression, alpha blending and flicker filtering

Video Interfaces

- 80 MHz 8- / 16-bit CCIR 601 / 656 YCbCr video input port supports capture resolutions up to 1920x1080i (EM8475 and EM8476 only)
- 80 MHz 8- / 16-bit CCIR 656 / 601 YCbCr video output port
- 80 MHz 24-bit RGB video output port for DVI with HDCP support (EM8475 and EM8476 only)
- NTSC/PAL composite and s-video analog outputs with optional Macrovision v7.1 protection (10-bit DACs)
- Analog RGB / YPbPr (SDTV or HDTV resolution, interlaced or progressive) with optional Macrovision AGC v1.03 protection in 480p output mode (10-bit DACs, EM8475 and EM8476 only)

Audio Decoding Standards

- 16-bit linear PCM
- MPEG-1 Layers 1 and 2
- MPEG-4 High Quality Profile Level 2
 - CELP and low-complexity AAC
- Dolby Digital down-mixed to 2 channels

Audio Interfaces

- I2S serial digital output for PCM or S/PDIF (IEC 60958) serial digital output for PCM, compressed Dolby Digital and compressed DTS
- I2S serial digital input (EM8475 and EM8476 only)
- On-chip stereo audio DACs (100 dB SNR, EM8475 and EM8476 only)

¹Without 1/4 pixel and global motion compensation

General Specifications (continued)

Host Interface

- PCI v2.1 with programmable burst length

Local Bus Interface

- PCI-to-Local Bus bridge
- 16-bit multiplexed address / data (Intel mode)
- 16-bit data and 8-bit address (generic mode)
- 16-bit data compressed
- Supports Stream Machine SM2210 / SM2288 MPEG encoder

Power Management

- 2.5V core with 3.3V I/O (5V tolerant)
- Typical power dissipation:
 - Analog video outputs off: 1.2W
 - Analog video outputs on: 1.4W

Package

- 208-pin PQFP for EM8470 and EM8471 (pin compatible with EM8400)
- 328-pin BGA for EM8475 and EM8476

Product Selection Guide

| Feature | EM8470¹ | EM8471² | EM8475¹ | EM8476² |
|--|---------------------------|---------------------------|---------------------------|---------------------------|
| Media Formats DVD-Video, Superbit DVD, SVCD, VCD 1.x, VCD 2.0, audio CD | yes | yes | yes | yes |
| Video Decoding MPEG-1, MPEG-2 MP@ML, MPEG-4 Advanced Simple Profile Level 5 ³ | yes | yes | yes | yes |
| Audio Decoding Dolby Digital, MPEG-1 Layers 1 and 2 MPEG-4 High Quality Profile Level 2 | yes yes | yes yes | yes yes | yes yes |
| Digital Video Inputs 8- / 16-bit YCbCr (80 MHz) | - | - | yes | yes |
| Digital Video Outputs 8- / 16-bit YCbCr (80 MHz) 24-bit RGB for DVI / HDCP support (80 MHz) | yes - | yes - | yes yes | yes yes |
| NTSC/PAL Composite and S-video Outputs Macrovision v7.1 protection | yes yes | yes - | yes yes | yes - |
| YPbPr or RGB Analog Video Outputs Macrovision AGC v1.03 protection for 480p output mode | - - | - - | yes yes | yes - |
| Audio Inputs and Outputs Stereo analog output S/PDIF / I2S digital output I2S digital input | - yes - | - yes - | yes yes yes | yes yes yes |
| Local Bus Interface | - | - | yes | yes |
| Package | 208 PQFP | 208 PQFP | 328 BGA | 328 BGA |
| Power Supply | 2.5v / 3.3v | 2.5v / 3.3v | 2.5v / 3.3v | 2.5v / 3.3v |

¹May be sampled or sold only to companies that are both Macrovision and Dolby licensed.

²May be sampled or sold only to companies that are Dolby licensed.

³Without 1/4 pixel and global motion compensation.

Copyright © 2002 by Sigma Designs, Inc. All rights reserved. Sigma Designs, REALmagic and the REALmagic logo are either registered trademarks or trademarks of Sigma Designs, Inc. in the United States and/or other countries. Manufactured under license from Dolby Laboratories and Macrovision. Dolby and the double-D symbol are trademarks of Dolby Laboratories. All other trademarks or registered trademarks are the property of their respective owners.

Sigma Designs products are sold by description only. Sigma Designs reserves the right to make changes in circuit design and / or specifications at any time without notice. Accordingly, the reader is cautioned to verify that data sheets are current before placing orders. Information furnished by Sigma Designs is believed to be accurate and reliable. However, no responsibility is assumed by Sigma Designs or its subsidiaries for its use; nor for any infringements of patents or other rights of third parties which may result from its use. No license is granted by implication or otherwise under any patent or patent rights of Sigma Designs or its subsidiaries.

Sales Offices

UNITED STATES

Sigma Designs, Inc.
355 Fairview Way
Milpitas, CA 95035
+1 (408) 262-9003
+1 (408) 957-9740 FAX

CHINA

Sigma Designs China
Room C1, 32F
Electronic Science & Technology Building (Phase 2)
30 Shennan Road Central
Shenzhen, PRC
Postcode 518031
+86 755 3683878
+86 755 3683873 FAX

EUROPE

Sigma Designs, Inc.
49, Rue des Moissonneurs
Brussels, Belgium 1040
+32 496.501234
+32 234.72260 FAX

HONG KONG

Sigma Designs (Asia) Ltd.
Unit 1516, Tower 1, Metroplaza
223 Hing Fong Road
Kwai Fong, N.T.
Hong Kong
+852 2401 7388
+852 2610 2177 FAX

JAPAN

Sigma Designs Japan
4-16-8 Nakahara,
Mitaka-shi,
Tokyo 181-0005, Japan
+81 422 79 3067
+81 422 79 3067 FAX

KOREA

Sigma Designs Korea
801, Dongil Techno Tower B/D
Kuro-dong, Kuro-gu,
Seoul, Korea
+82 11 288 0406
+82 2 3281 2034 FAX

TAIWAN

Sigma Designs Taiwan
Far East World Center, C Tower
8F-8, No. 79, Sec. 1
Hsin Tai Wu Road
Hsichih, Taipei Hsien
Taiwan, R.O.C.
+886 2 2698 2066
+886 2 2698 2099 FAX

Revision Date: March 18, 2002