



# 1.4MHz SOT23 Current-Mode Step-Up DC-DC Converter

**MAX1896**

## General Description

The MAX1896 step-up DC-DC converter incorporates high-performance current-mode, fixed-frequency, pulse-width modulation (PWM) circuitry and an internal 0.7Ω N-channel MOSFET to provide a highly efficient regulator with fast response.

High switching frequency (1.4MHz) allows fast loop response and easy filtering with small components. The MAX1896 can produce an output voltage as high as 13V from an input as low as 2.6V. Soft-start is programmable with an external capacitor, which sets the input current ramp rate. In shutdown mode, current consumption is reduced to 0.01μA.

The MAX1896 is available in a space-saving 6-pin SOT23 package. The ultra-small package and high switching frequency allow cost and space-efficient implementations.

## Features

- ◆ >90% Efficiency
- ◆ Adjustable Output Up to 13V
- ◆ Guaranteed 12V/120mA Output from 5V Input
- ◆ 2.6V to 5.5V Input Range
- ◆ LT1613 Pin Compatible
- ◆ 0.01μA Shutdown Current
- ◆ Programmable Soft-Start
- ◆ Space-Saving 6-Pin SOT23 Package

## Applications

- Notebook Computers
- LCD Displays
- PCMCIA Cards
- Portable Applications
- Hand-Held Devices

## Ordering Information

PART	TEMP. RANGE	PIN-PACKAGE
MAX1896EUT-T	-40°C to +85°C	6 SOT23-6

## Typical Operating Circuit

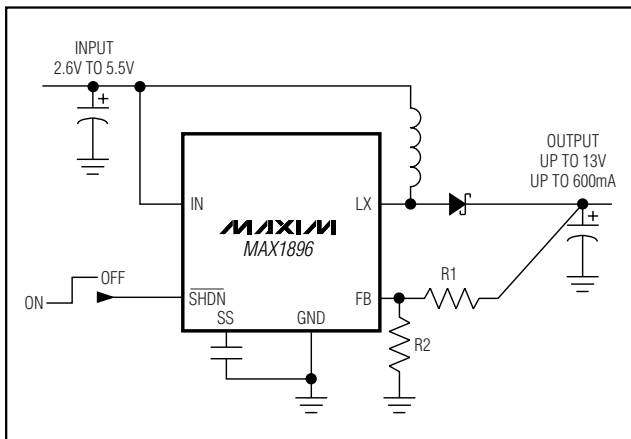

## Pin Configuration

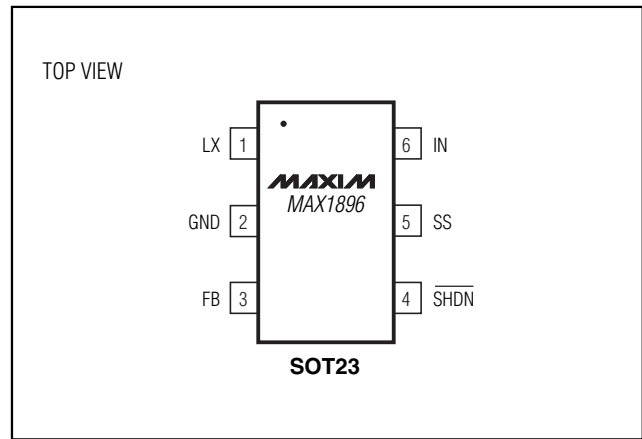

# 1.4MHz SOT23 Current-Mode Step-Up DC-DC Converter

## ABSOLUTE MAXIMUM RATINGS

LX to GND .....	-0.3V to +14V	Operating Temperature Range .....	-40°C to +85°C
IN, $\overline{\text{SHDN}}$ , FB to GND.....	-0.3V to +6V	Junction Temperature .....	+150°C
SS to GND .....	-0.3V to ( $V_{\text{IN}} + 0.3\text{V}$ )	Storage Temperature Range .....	-65°C to +150°C
RMS LX Pin Current .....	0.6A	Lead Temperature (soldering, 10s) .....	+300°C
Continuous Power Dissipation ( $T_{\text{A}} = +70^{\circ}\text{C}$ ) (Note 1)			
6-Pin SOT23 (derate 9.1mW/°C above +70°C).....	727mW		

**Note 1:** Thermal properties are specified with product mounted on PC board with one square-inch of copper area and still air.

Stresses beyond those listed under "Absolute Maximum Ratings" may cause permanent damage to the device. These are stress ratings only, and functional operation of the device at these or any other conditions beyond those indicated in the operational sections of the specifications is not implied. Exposure to absolute maximum rating conditions for extended periods may affect device reliability.

## ELECTRICAL CHARACTERISTICS

( $V_{\text{IN}} = V_{\overline{\text{SHDN}}} = 3\text{V}$ ,  $\text{FB} = \text{GND}$ ,  $\text{SS} = \text{open}$ ,  $T_{\text{A}} = 0^{\circ}\text{C}$  to  $+85^{\circ}\text{C}$ , unless otherwise noted.)

PARAMETER	SYMBOL	CONDITIONS	MIN	TYP	MAX	UNITS
Input Supply Range	$V_{\text{IN}}$		2.6		5.5	V
Output Voltage Adjust Range	$V_{\text{OUT}}$	Circuit of Figure 1			13	V
$V_{\text{IN}}$ Undervoltage Lockout	UVLO	$V_{\text{IN}}$ rising, 50mV hysteresis	2.25	2.4	2.55	V
Quiescent Current	$I_{\text{IN}}$	$V_{\text{FB}} = 1.3\text{V}$ , not switching		0.2	0.4	mA
		$V_{\text{FB}} = 1.0\text{V}$ , switching		1	5	
Shutdown Supply Current		$V_{\overline{\text{SHDN}}} = 0$ , $T_{\text{A}} = +25^{\circ}\text{C}$		0.01	0.5	$\mu\text{A}$
		$V_{\overline{\text{SHDN}}} = 0$		0.01	10	
<b>ERROR AMPLIFIER</b>						
Feedback Regulation Set Point	$V_{\text{FB}}$		1.2	1.24	1.25	V
FB Input Bias Current	$I_{\text{FB}}$	$V_{\text{FB}} = 1.24\text{V}$		21	80	nA
Line Regulation		$2.6\text{V} < V_{\text{IN}} < 5.5\text{V}$		0.05	0.20	%/V
<b>OSCILLATOR</b>						
Frequency	$f_{\text{OSC}}$		1000	1400	1800	kHz
Maximum Duty Cycle	DC		82	86		%
<b>POWER SWITCH</b>						
Current Limit (Note 2)	$I_{\text{LIM}}$	$V_{\text{FB}} = 1\text{V}$ , duty cycle = 50%	0.55	0.8		A
On-Resistance	$R_{\text{ON}}$			0.7	1	$\Omega$
Leakage Current	$I_{\text{LXOFF}}$	$V_{\text{LX}} = 12\text{V}$ , $T_{\text{A}} = +25^{\circ}\text{C}$		0.1	1	$\mu\text{A}$
		$V_{\text{LX}} = 12\text{V}$			10	
<b>SOFT-START</b>						
Reset Switch Resistance					100	$\Omega$
Charge Current		$V_{\text{SS}} = 1.2\text{V}$	1.5	4	7.0	$\mu\text{A}$
<b>CONTROL INPUT</b>						
Input Low Voltage	$V_{\text{IL}}$	$V_{\overline{\text{SHDN}}}$ , $V_{\text{IN}} = 2.6\text{V}$ to $5.5\text{V}$			0.3	V
Input High Voltage	$V_{\text{IH}}$	$V_{\overline{\text{SHDN}}}$ , $V_{\text{IN}} = 2.6\text{V}$ to $5.5\text{V}$	1.0			V
$\overline{\text{SHDN}}$ Input Current	$I_{\overline{\text{SHDN}}}$	$V_{\overline{\text{SHDN}}} = 3\text{V}$		25	50	$\mu\text{A}$
		$V_{\overline{\text{SHDN}}} = 0$		0.01	0.1	

# 1.4MHz SOT23 Current-Mode Step-Up DC-DC Converter

MAX1896

## ELECTRICAL CHARACTERISTICS

( $V_{IN} = V_{SHDN} = 3V$ ,  $FB = GND$ ,  $SS = open$ ,  $T_A = -40^{\circ}C$  to  $+85^{\circ}C$ , unless otherwise noted.) (Note 3)

PARAMETER	SYMBOL	CONDITIONS	MIN	TYP	MAX	UNITS
Input Supply Range	$V_{IN}$		2.6		5.5	V
Output Voltage Adjust Range	$V_{OUT}$	Circuit of Figure 1			13	V
$V_{IN}$ Undervoltage Lockout	UVLO	$V_{IN}$ rising, 50mV hysteresis.	2.25		2.55	V
Quiescent Current	$I_{IN}$	$V_{FB} = 1.3V$ , not switching			0.4	mA
		$V_{FB} = 1.0V$ , switching			5	
Shutdown Supply Current		$V_{SHDN} = 0$			10	$\mu A$
<b>ERROR AMPLIFIER</b>						
Feedback Regulation Set Point	$V_{FB}$		1.2		1.25	V
FB Input Bias Current	$I_{FB}$	$V_{FB} = 1.24V$			80	nA
Line Regulation		$2.6V < V_{IN} < 5.5V$			0.20	%/V
<b>OSCILLATOR</b>						
Frequency	$f_{OSC}$		1000		1800	kHz
Maximum Duty Cycle	DC		82			%
<b>POWER SWITCH</b>						
Current Limit (Note 2)	$I_{LIM}$	$V_{FB} = 1V$ , duty cycle = 50%	0.55			A
On-Resistance	$R_{ON}$				1	$\Omega$
Leakage Current	$I_{LXOFF}$	$V_{LX} = 12V$			10	$\mu A$
<b>SOFT-START</b>						
Reset Switch Resistance					100	$\Omega$
Charge Current		$V_{SS} = 1.2V$	1.25		7.50	$\mu A$
<b>CONTROL INPUT</b>						
Input Low Voltage	$V_{IL}$	$V_{SHDN} = V_{IN} = 2.6V$ to $5.5V$			0.3	V
Input High Voltage	$V_{IH}$	$V_{SHDN} = V_{IN} = 2.6V$ to $5.5V$	1.0			V
$\overline{SHDN}$ Input Current	$I_{\overline{SHDN}}$	$V_{SHDN} = 3V$			50	$\mu A$
		$V_{SHDN} = 0$			0.1	

**Note 2:** Current limit varies with duty cycle due to slope compensation. See the *Output Current Capability* section.

**Note 3:** Specifications to  $-40^{\circ}C$  are guaranteed by design and not production tested.

# 1.4MHz SOT23 Current-Mode Step-Up DC-DC Converter

## Typical Operating Characteristics

(Circuit of Figure 1,  $V_{IN} = 3.3V$ ,  $T_A = +25^\circ C$ , unless otherwise noted.)

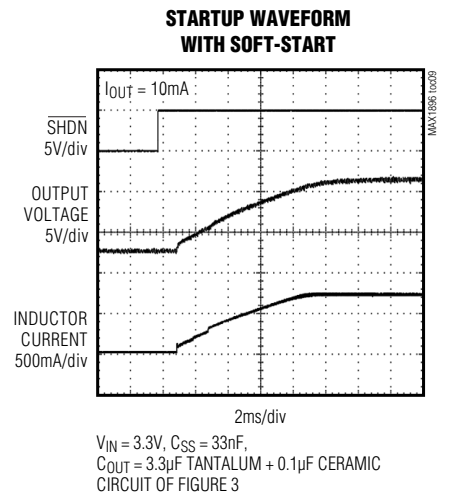
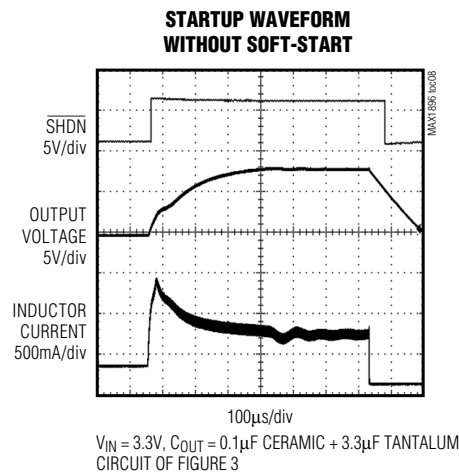
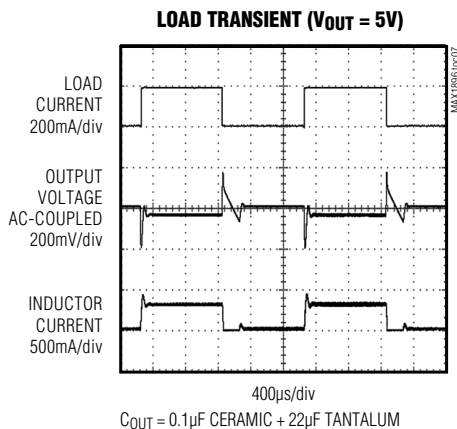
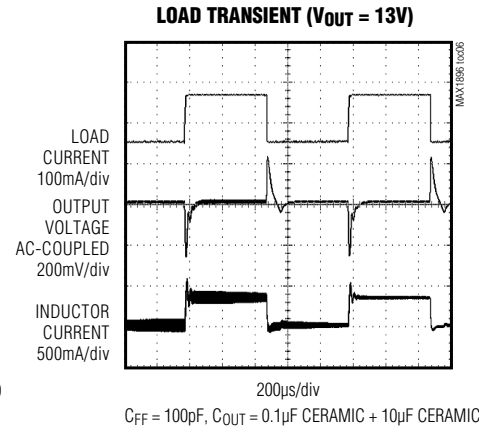
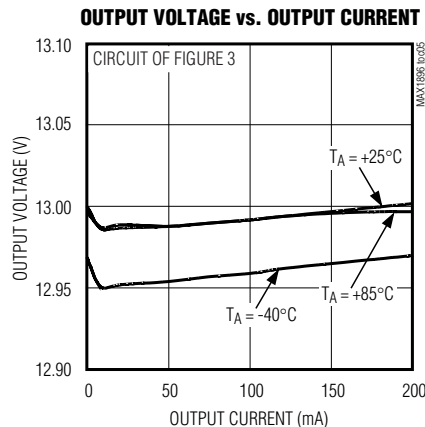
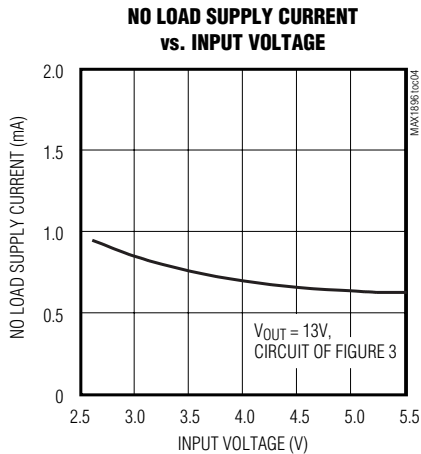
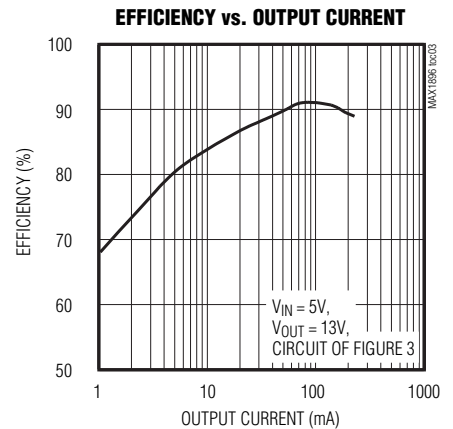
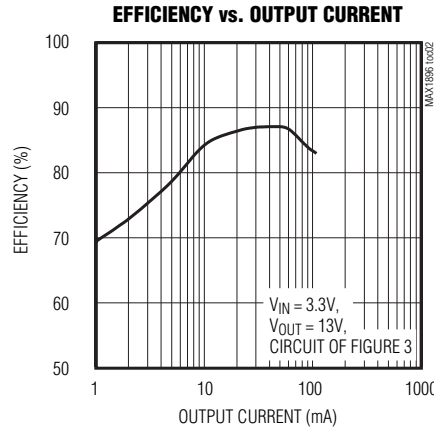
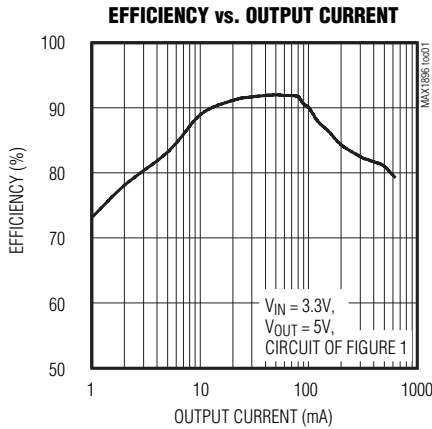

# 1.4MHz SOT23 Current-Mode Step-Up DC-DC Converter

MAX1896

## Typical Operating Characteristics (continued)

(Circuit of Figure 1,  $V_{IN} = 3.3V$ ,  $T_A = +25^\circ C$ , unless otherwise noted.)

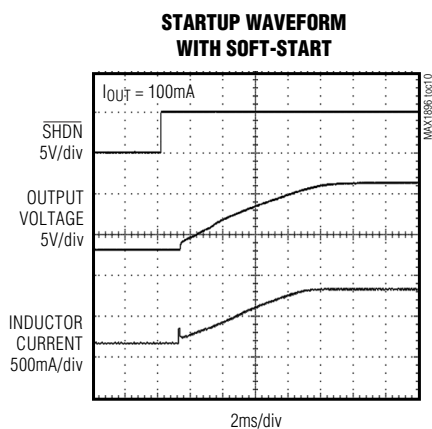

$V_{IN} = 3.3V$ ,  $C_{SS} = 33nF$ ,  
 $C_{OUT} = 3.3\mu F$  TANTALUM +  $0.1\mu F$  CERAMIC  
 CIRCUIT OF FIGURE 3

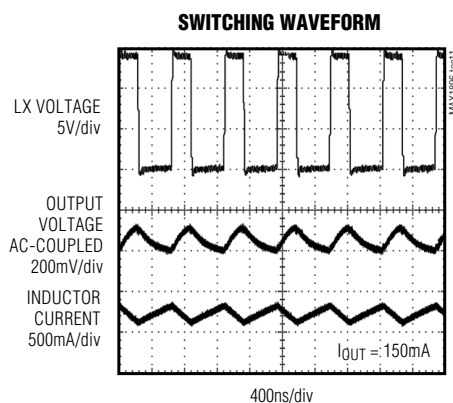

$V_{IN} = 5V$ ,  
 $C_{OUT} = 0.1\mu F$  CERAMIC +  $2.2\mu F$  CERAMIC

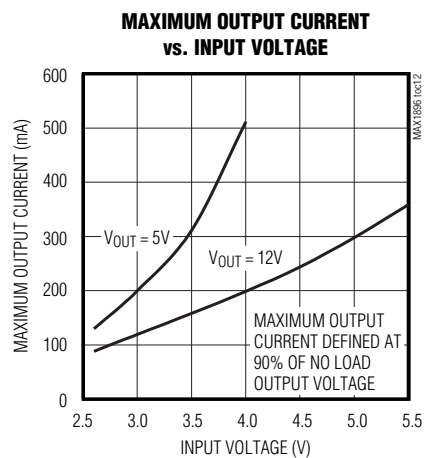

## Pin Description

PIN	NAME	FUNCTION
1	LX	Power Switching Connection. Connect LX to the inductor and output rectifier. Connect components as close to LX as possible.
2	GND	Ground
3	FB	Feedback Input. Connect a resistive voltage-divider from the output to FB to set the output voltage. See the <i>Setting the Output Voltage</i> section.
4	$\overline{SHDN}$	Shutdown Input. Drive $\overline{SHDN}$ low to turn off the converter. To automatically start the converter, connect $\overline{SHDN}$ to IN. Drive $\overline{SHDN}$ with a slew rate of $0.1V/\mu s$ or greater. Do not leave $\overline{SHDN}$ unconnected. $\overline{SHDN}$ draws up to $50\mu A$ .
5	SS	Soft-Start Input. Connect a soft-start capacitor from SS to GND to soft-start the converter. Leave SS open to disable the soft-start function. See the <i>Soft-Start</i> section.
6	IN	Internal Bias Voltage Input. Connect IN to the input voltage source. Bypass IN to GND with a $1\mu F$ or greater capacitor as close to IN as possible.

# 1.4MHz SOT23 Current-Mode Step-Up DC-DC Converter

## Detailed Description

The MAX1896 is a highly efficient power supply that employs a current-mode, fixed-frequency pulse-width modulation (PWM) architecture for fast-transient response and low-noise operation. The functional diagram is shown in Figure 2. As the load varies, the error amplifier sets the inductor peak current necessary to supply the load and regulate the output voltage. To maintain stability at high duty cycle, a slope-compensation signal is internally summed with the current-sense signal.

At light loads, this architecture allows the MAX1896 to skip cycles to prevent overcharging the output voltage. In this region of operation, the inductor ramps up to a peak value of about 100mA, discharges to the output and waits until another pulse is needed again.

## Output-Current Capability

The output-current capability of the MAX1896 is a function of current limit, input voltage, and inductor value. Because of the slope compensation used to stabilize the feedback loop, the duty cycle affects the current limit. The output-current capability is governed by the following equation:

$$I_{OUT(MAX)} = \left[ (I_{LIM} \times (1.45 - 0.9 \times \text{Duty})) - \left( \frac{0.5 \times \text{Duty} \times V_{IN}}{f_{OSC} \times L} \right) \right] \times \eta \times \frac{V_{IN}}{V_{OUT}}$$

where:

$I_{LIM}$  = current limit specified at 50% (see *Electrical Characteristics*)

$$\text{DUTY} = \text{DUTY CYCLE} = \frac{V_{OUT} - V_{IN} + V_{DIODE}}{V_{OUT} - I_{LIM} \times R_{ON} + V_{DIODE}}$$

$V_{DIODE}$  = catch diode forward drop at  $I_{LIM}$ , (V)

$f_{OSC}$  = oscillator frequency, (Hz)

$L$  = inductor value, (H)

$\eta$  = conversion efficiency, 0.85 nominal

$V_{IN}$  = input voltage, (V)

$V_{OUT}$  = output voltage, (V)

## Soft-Start

The MAX1896 can be programmed for soft-start upon power-up with an external capacitor. When the MAX1896 is turned on, the soft-start capacitor ( $C_{SS}$ ) is charged at a constant current of 4 $\mu$ A, ramping up to 0.5V. During this time, the SS voltage directly controls the peak-inductor current, allowing 0A at  $V_{SS} = 0.5V$  to the full current limit at  $V_{SS} = 1.5V$ . The maximum load current is available after the soft-start cycle is completed. When the MAX1896 is turned off, the soft-start capacitor is internally discharged to ground.

## Shutdown

The MAX1896 shuts down to reduce the supply current to 0.01 $\mu$ A when  $\overline{\text{SHDN}}$  is low. In this mode, the internal reference, error amplifier, comparators, biasing circuit, and N-channel MOSFET are turned off. The step-up converter's output is still connected to IN via the external inductor and output rectifier.

## Applications Information

The MAX1896 operates well with a variety of external components. The components in Figure 1 are suitable for most applications. See the following sections to optimize external components for a particular application.

## Inductor Selection

Inductor selection depends on input voltage, output voltage, maximum current, size, and availability of inductor values. Other factors can include efficiency and ripple voltage. Inductors are specified by their inductance ( $L$ ), peak current ( $I_{PK}$ ), and resistance ( $R_L$ ). The following step-up circuit equations are useful in choosing the inductor values based on the application. They allow the trading of peak current and inductor value while considering component availability and cost.

The equation used here assumes a constant LIR, which is the ratio of the inductor peak-to-peak AC current to average DC inductor current. A good compromise between the size of the inductor versus loss and output ripple is to choose an LIR of 0.3 to 0.5. The peak inductor current is then given by:

$$I_{PK} = \left( \frac{I_{OUT(MAX)} \times V_{OUT}}{\eta \times V_{IN(MIN)}} \right) \times \left( 1 + \frac{\text{LIR}}{2} \right)$$

where:

$I_{OUT(MAX)}$  = maximum output current, (A)

$V_{IN(MIN)}$  = minimum input voltage, (V)

# 1.4MHz SOT23 Current-Mode Step-Up DC-DC Converter

The inductance (H) value is then given by:

$$L = \frac{[V_{IN(MIN)}]^2 \times \eta \times (V_{OUT} - V_{IN(MIN)})}{V_{OUT}^2 \times LIR \times I_{OUT(MAX)} \times f_{OSC}}$$

## Diode Selection

The output diode should be rated to handle the output voltage and the peak switch current. Make sure the diode's peak current rating is at least  $I_{PK}$  and that its breakdown voltage exceeds  $V_{OUT}$ . Schottky diodes are recommended. If a junction rectifier is used, it must be an ultra-fast type ( $t_{rr} < 50ns$ ) to prevent excessive loss in the rectifier.

## Input and Output Capacitor Selection

The MAX1896 operates with both tantalum and ceramic output capacitors. When using tantalum capacitors, the zero caused by the ESR of the tantalum is used to ensure stability. When using ceramic capacitors, the zero due to the ESR will be at too high a frequency to be useful in stabilizing the control loop. When using ceramic capacitors, use a feedforward capacitor to increase the phase margin, improving the control-loop stability. Figure 3 shows the circuit with ceramic capacitors and the feedforward capacitor,  $C_{FF}$ . Use the following equation to determine the value of the feedforward capacitor:

$$C_{FF} = \frac{k_1}{R_1} \times \left[ \frac{C_{OUT} \times V_{OUT}^2}{V_{IN}} \right]^{0.5}$$

where:

$$k_1 = 7.14 \times 10^{-4} \text{ with units of } \left( \frac{\Omega \times F}{A} \right)^{0.5}$$

$R_1$  = see Figure 3, ( $\Omega$ )

$C_{OUT}$  = total output capacitance including any bypass capacitor on the output bus, (Farads). See Figure 3.

$V_{OUT}$  = output voltage, (V)

$V_{IN}$  = input voltage, (V).

## Setting the Output Voltage

The MAX1896 operates with an adjustable output from  $V_{IN}$  to 13V. Connect a resistive voltage-divider from the output to FB (see *Typical Operating Circuit*). Choose a value for  $R_2$  between 10k $\Omega$  and 50k $\Omega$ . Calculate  $R_1$  using the equation:

$$R_1 = R_2 \times \left( \frac{V_{OUT}}{V_{FB}} - 1 \right)$$

where  $V_{FB}$ , the step-up regulator feedback set point, is 1.24V. Connect the resistive-divider as close to the IC as possible.

## Soft-Start Capacitor

The soft-start capacitor should be large enough that the current limit does not reach final value before the output has reached regulation. Calculate  $C_{SS}$  to be:

$$C_{SS} > k_2 \times C_{OUT} \times \left[ \frac{V_{OUT}^2 - V_{IN} \times V_{OUT}}{V_{IN} \times I_{INRUSH} - I_{OUT} \times V_{OUT}} \right]$$

where:

$k_2 = 21 \times 10^{-6}$ , (S)

$V_{OUT}$  = maximum output voltage, (V)

$I_{INRUSH}$  = peak inrush current allowed, (A)

$I_{OUT}$  = maximum output current during power-up stage, (A)

$V_{IN}$  = minimum input voltage, (V)

The soft-start duration ( $t_{SS}$ ) is the time it takes the current limit to reach its final value. The soft-start duration can be calculated by the equation:

$$t_{SS} = k_3 \times C_{SS}$$

where:

$$k_3 = 6.67 \times 10^5 \Omega$$

# 1.4MHz SOT23 Current-Mode Step-Up DC-DC Converter

## Application Circuits

### 1-Cell to 3.3V SEPIC Power Supply

Figure 4 shows the MAX1896 in a single-ended primary inductance converter (SEPIC) topology. This topology is useful when the input voltage can be either higher or lower than the output voltage, such as when converting a single lithium-ion (Li+) cell to a 3.3V output. L1 and L2 are two windings on a single inductor or two separate inductors. The coupling capacitor between these two windings must be a low-ESR type to achieve maximum efficiency, and must also be able to handle high ripple currents. Ceramic capacitors are best for this application.

## Layout Procedure

Good PC board layout and routing are required in high-frequency switching power supplies to achieve good regulation, and stability. It is strongly recommended that the evaluation kit PC board layouts be followed as closely as possible. Refer to the MAX1896 EV kit for a good layout. Place power components as close together as possible, keeping their traces short, direct, and wide. Avoid interconnecting the ground pins of the power components using vias through an internal ground plane. Instead, keep the power components close together and route them in a star ground configuration using component side copper, then connect the star ground to internal ground using multiple vias.

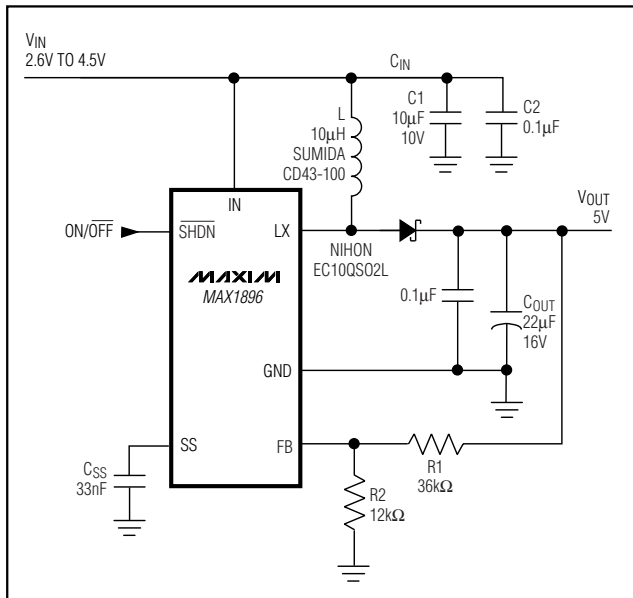

Figure 1. Typical Application Circuit

## Chip Information

TRANSISTOR COUNT: 970



# 1.4MHz SOT23 Current-Mode Step-Up DC-DC Converter

**MAX1896**

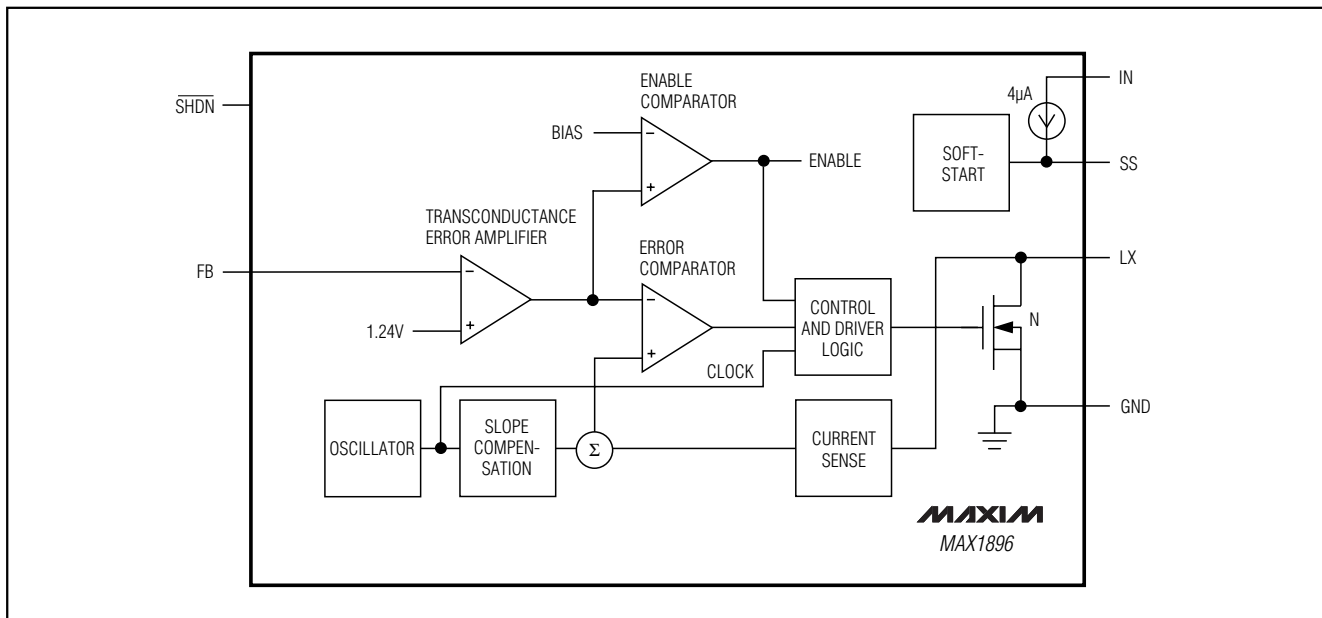

Figure 2. Functional Diagram

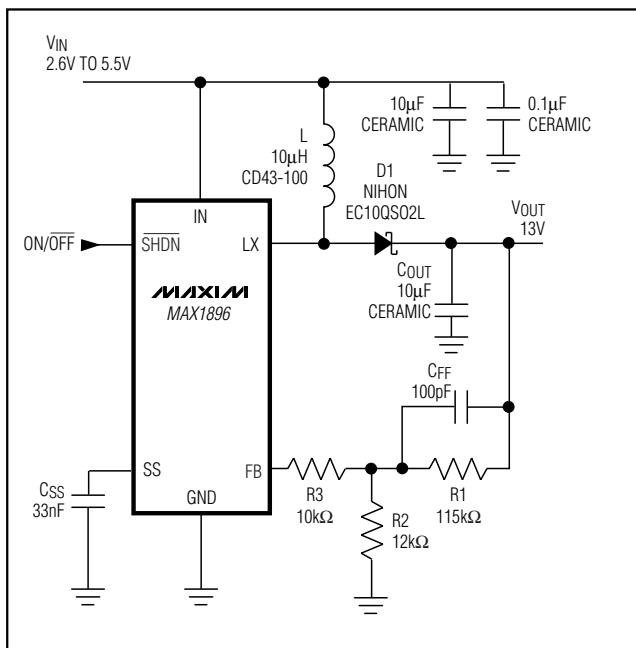

Figure 3. MAX1896 with Ceramic Output Capacitor and Feed-forward Capacitor

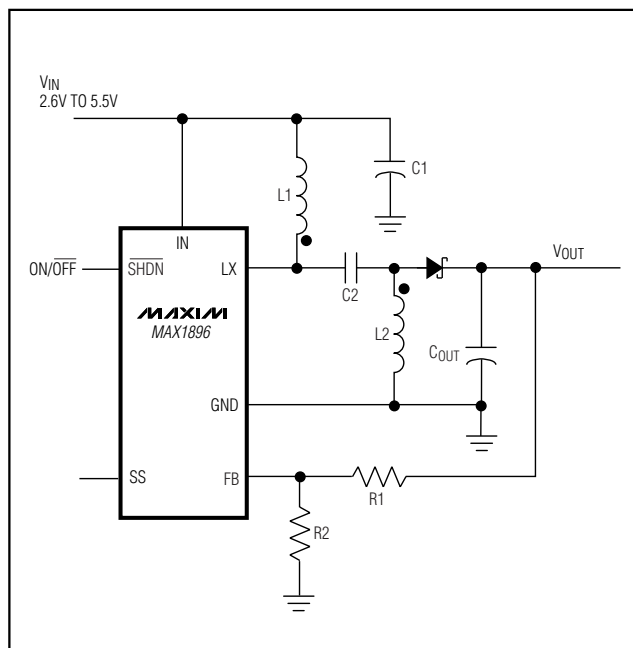
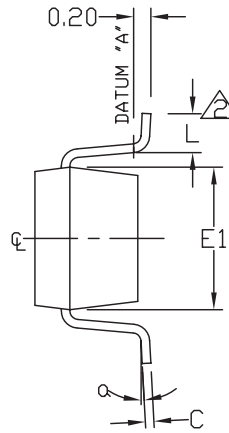
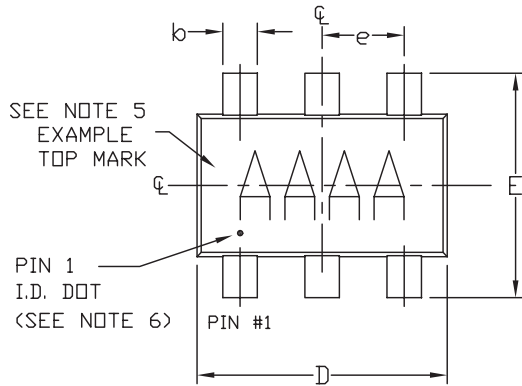

Figure 4. MAX1896 in an SEPIC Configuration

# 1.4MHz SOT23 Current-Mode Step-Up DC-DC Converter

## Package Information

6LSOT23EFS



SYMBOL	MIN	MAX
A	0.90	1.45
A1	0.00	0.15
A2	0.90	1.30
b	0.35	0.50
C	0.08	0.20
D	2.80	3.00
E	2.60	3.00
E1	1.50	1.75
L	0.35	0.55
e	0.95 REF	
α	0°	10°

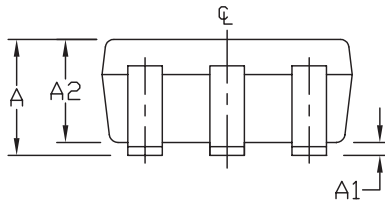

NOTES:

1. ALL DIMENSIONS ARE IN MILLIMETERS.
2. FOOT LENGTH MEASURED AT INTERCEPT POINT BETWEEN DATUM A & LEAD SURFACE.
3. PACKAGE OUTLINE EXCLUSIVE OF MOLD FLASH & METAL BURR.
4. PACKAGE OUTLINE INCLUSIVE OF SOLDER PLATING.
5. PIN 1 IS LOWER LEFT PIN WHEN READING TOP MARK FROM LEFT TO RIGHT. (SEE EXAMPLE TOP MARK)
6. PIN 1 I.D. DOT IS 0.3 MM Ø MIN. LOCATED ABOVE PIN 1.
7. MEETS JEDEC MO178.

**MAXIM**  
PROPRIETARY INFORMATION  
 TITLE:  
**PACKAGE OUTLINE, SOT-23, 6L**  
 APPROVAL: \_\_\_\_\_ DOCUMENT CONTROL NO. 21-0058 REV. E 1/1

Maxim cannot assume responsibility for use of any circuitry other than circuitry entirely embodied in a Maxim product. No circuit patent licenses are implied. Maxim reserves the right to change the circuitry and specifications without notice at any time.

10 \_\_\_\_\_ **Maxim Integrated Products, 120 San Gabriel Drive, Sunnyvale, CA 94086 408-737-7600**