

TC74HC40105AP, TC74HC40105AF

4 Bit×16 Word FIFO REGISTER

The TC74HC40105A is a high speed CMOS 4bit×16word first - in, first - out (FIFO) Strage Register fabricated with silicon gate C²MOS technology.

It achieves the high speed operation while maintaining the CMOS low power dissipation.

The device is capable of handling 16 four - bit words and it is possible to handle the input and output data at different shifting rates.

When the DATA - IN - READY (DIR) is high, data is written into the registers by a low to high transition of the SHIFT IN (SI) input. And when DATA - OUT - READY (DOR) is high, data is read out of the registers by a high to low transition of the SHIFT OUT (SO) input.

If the MASTER RESET (MR) is high, the DIR goes high and DOR goes low. The data in the internal registers are not changed but are declared invalid.

The TC74HC40105A can be cascaded to form longer registers or wider words.

The DATA OUTPUTs (Q_n) are 3 - State Outputs. When OUTPUT ENABLE (\overline{OE}) is held high, the Q_n's are in high impedance state.

All inputs are equipped with protection circuits against static discharge or transient excess voltage.

FEATURES:

- High Speed..... $f_{MAX} = 25\text{MHz}(\text{typ.})$ at $V_{CC} = 5\text{V}$
- Low Power Dissipation..... $I_{CC} = 4\mu\text{A}(\text{Max.})$ at $T_a = 25^\circ\text{C}$
- High Noise Immunity..... $V_{NIH} = V_{NIL} = 28\% V_{CC} (\text{Min.})$
- Output Drive Capability 10 LSTTL Loads For DIR,DOR
15 LSTTL Loads For Q₀~Q₃
- Symmetrical Output Impedance...

$$\begin{cases} |I_{OH}| = I_{OL} = 4\text{mA}(\text{min.})\text{For DIR,DOR} \\ |I_{OH}| = I_{OL} = 6\text{mA}(\text{min.})\text{For Q}_0\sim\text{Q}_3 \end{cases}$$
- Balanced Propagation Delays..... $t_{pLH} \approx t_{pHL}$
- Wide Operating Voltage Range.... $V_{CC} (\text{opr.}) = 2\text{V}\sim 6\text{V}$

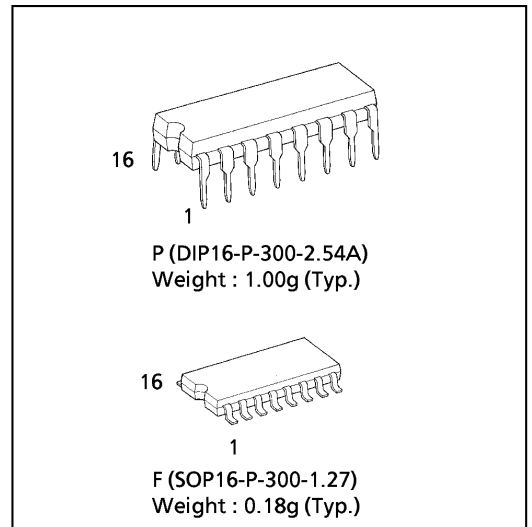

PIN ASSIGNMENT

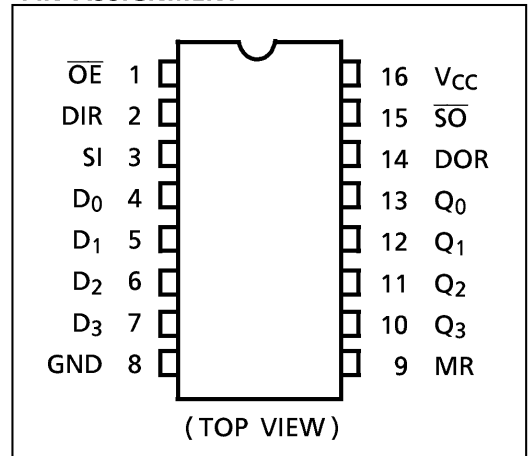

IEC LOGIC SYMBOL

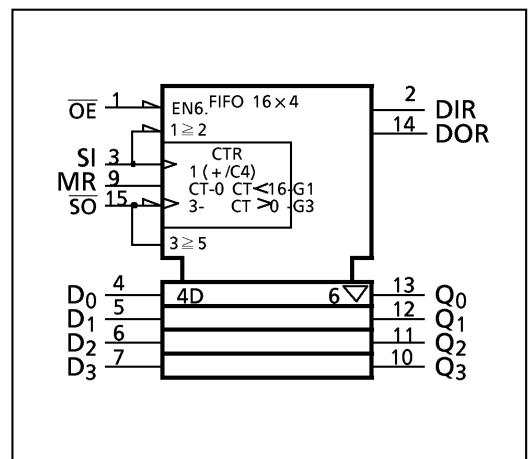

980910EBA2

● TOSHIBA is continually working to improve the quality and the reliability of its products. Nevertheless, semiconductor devices in general can malfunction or fail due to their inherent electrical sensitivity and vulnerability to physical stress. It is the responsibility of the buyer, when utilizing TOSHIBA products, to observe standards of safety, and to avoid situations in which a malfunction or failure of a TOSHIBA product could cause loss of human life, bodily injury or damage to property. In developing your designs, please ensure that TOSHIBA products are used within specified operating ranges as set forth in the most recent products specifications. Also, please keep in mind the precautions and conditions set forth in the TOSHIBA Semiconductor Reliability Handbook.

SYSTEM DIAGRAM

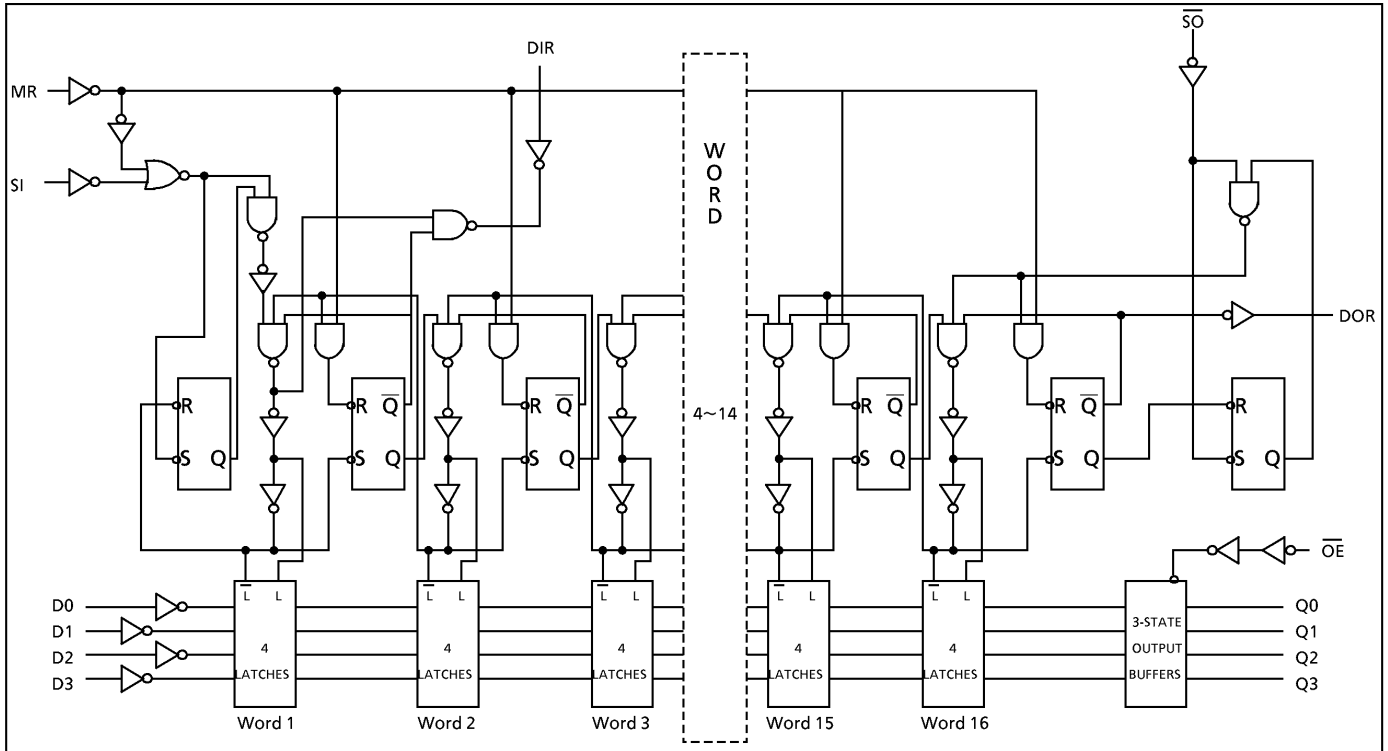

TIMING CHART

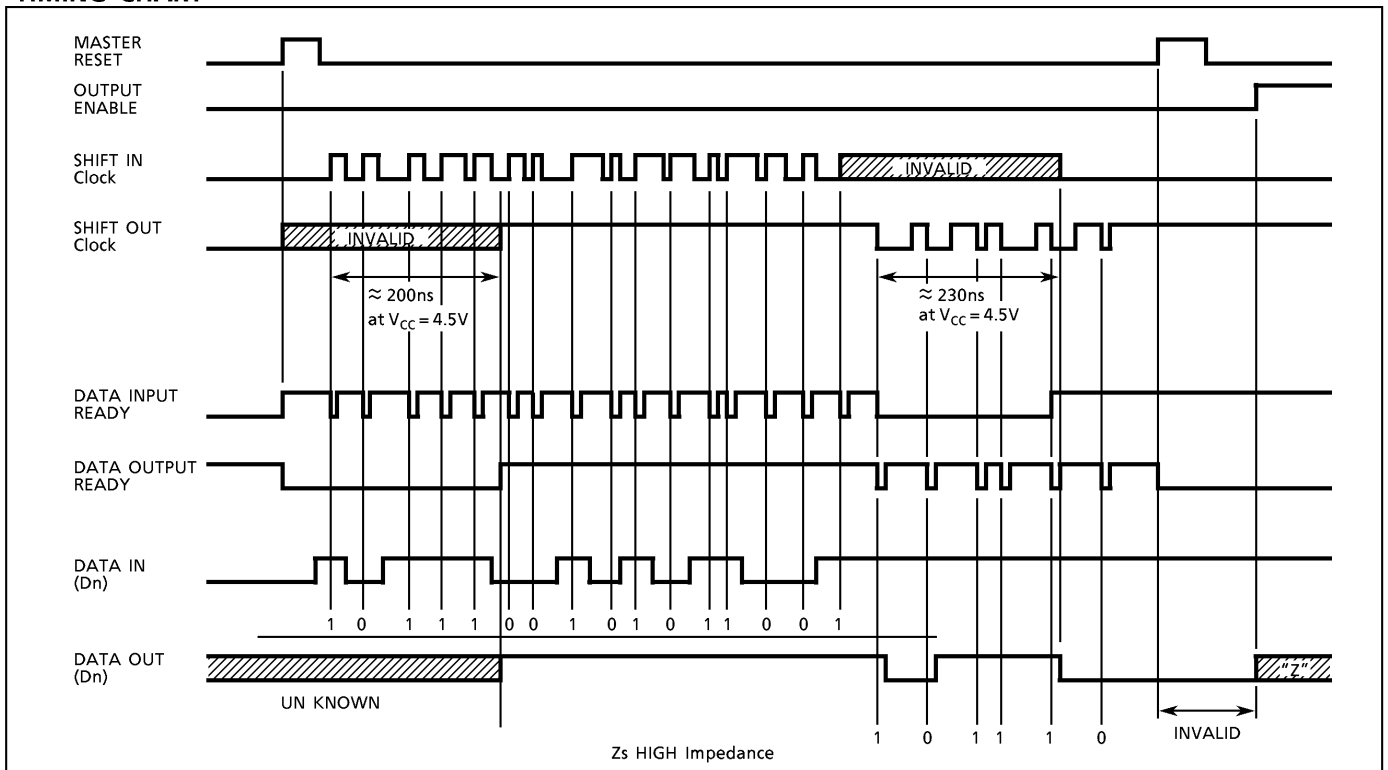

980910EBA2'

- The products described in this document are subject to the foreign exchange and foreign trade laws.
- The information contained herein is presented only as a guide for the applications of our products. No responsibility is assumed by TOSHIBA CORPORATION for any infringements of intellectual property or other rights of the third parties which may result from its use. No license is granted by implication or otherwise under any intellectual property or other rights of TOSHIBA CORPORATION or others.
- The information contained herein is subject to change without notice.

BLOCK DIAGRAM

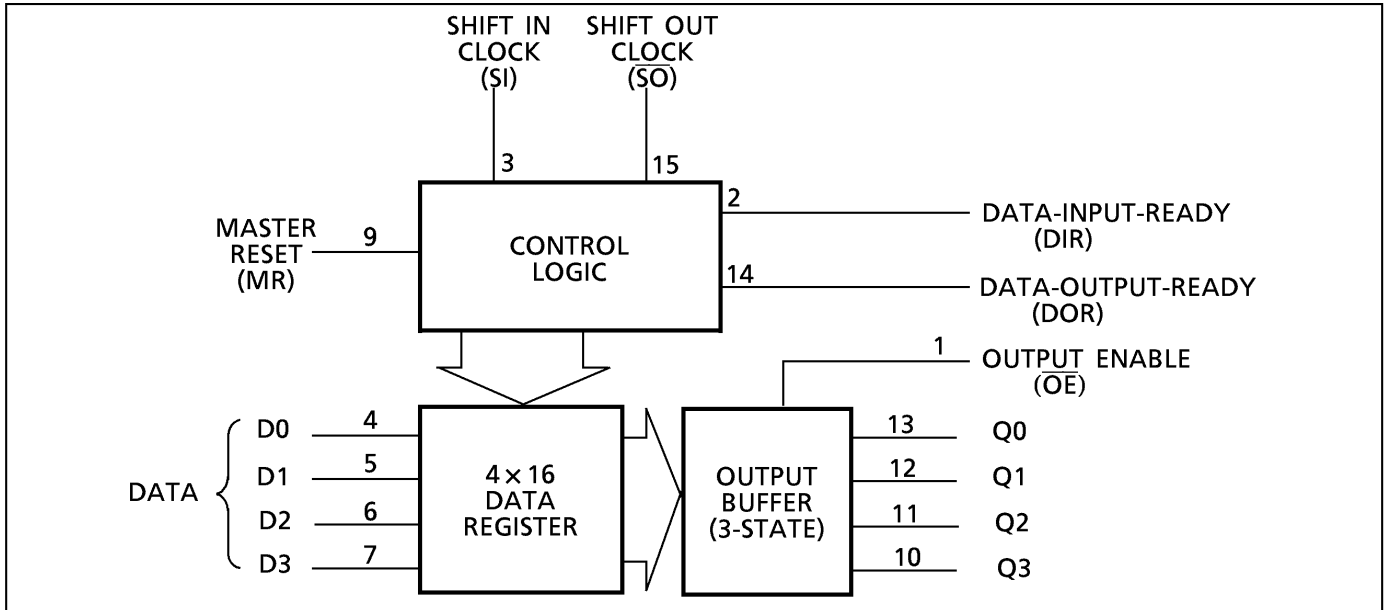

FUNCTIONAL DESCRIPTION

1) WRITING DATA

Data can be written into the FIFO whenever DIR is high and a low to high transition occurs on the SI pin.

DIR will toggle momentarily until the data has been transferred to the second word register.

SI must be toggled before the next 4-bit word can be written. The first and subsequent words will automatically ripple to the output end of the device even if there is not a full 16 words of input data. When all 16 words are filled with data, DIR will go low and additional data cannot be written into the device.

2) READING DATA

When a data word appears in the sixteenth data register (just before the output buffer), DOR goes high and, if OE is low, data can be output on the high to low transition of SO.

The data remaining in the registers now ripples to the next higher word position opening the first word position for new data. DIR goes high and additional data can be written in. During the output of data, DOR toggles momentarily after each read. When the data registers become empty, DOR goes low and SO is ignored.

3) MASTER REST

When a high is input to MR, the internal control logic is initialized. This causes DIR to go high and DOR to go low. The contents of the data registers are not changed, but are invalid and will be written over when the first word is loaded.

4) CASCADING

The TC74HC40105A can be cascaded to form longer registers simply by connecting DOR of the first device to SI of the second and DIR of the second device to SO of the first. Additional devices may be cascaded by repeating the above. Of course, the Qn outputs of the first device must be connected to the Dn inputs of the second.

In this mode, an MR pulse must be applied after the supply voltage is turned on. For words wider than 4-bits, the DIR and DOR outputs from each FIFO must be ANDed respectively and the SI and SO inputs must each be paralleled.

ABSOLUTE MAXIMUM RATINGS

PARAMETER	SYMBOL	VALUE	UNIT
Supply Voltage Range	V _{CC}	-0.5~7	V
DC Input Voltage	V _{IN}	-0.5~V _{CC} +0.5	V
DC Output Voltage	V _{OUT}	-0.5~V _{CC} +0.5	V
Input Diode Current	I _{IK}	± 20	mA
Output Diode Current	I _{OK}	± 20	mA
DC Output Current (DIR,DOR) (Q0~Q3)	I _{OUT}	± 25 ± 35	mA
DC V _{CC} /Ground Current	I _{CC}	± 75	mA
Power Dissipation	P _D	500 (DIP)* / 180 (SOP)	mW
Storage Temperature	T _{stg}	-65~150	°C

*500mW in the range of Ta = -40°C~65°C. From Ta = 65°C to 85°C a derating factor of -10mW/°C shall be applied until 300mW.

RECOMMENDED OPERATING CONDITIONS

PARAMETER	SYMBOL	VALUE	UNIT
Supply Voltage	V _{CC}	2~6	V
Input Voltage	V _{IN}	0~V _{CC}	V
Output Voltage	V _{OUT}	0~V _{CC}	V
Operating Temperature	T _{opr}	-40~85	°C
Input Rise and Fall Time	t _r , t _f	0~1000 (V _{CC} = 2.0V) 0~500 (V _{CC} = 4.5V) 0~400 (V _{CC} = 6.0V)	ns

DC ELECTRICAL CHARACTERISTICS

PARAMETER	SYMBOL	TEST CONDITION	V _{CC} (V)	Ta = 25°C			Ta = -40~85°C		UNIT
				MIN.	TYP.	MAX.	MIN.	MAX.	
High - Level Input Voltage	V _{IH}		2.0	1.50	—	—	1.50	—	V
			4.5	3.15	—	—	3.15	—	
			6.0	4.20	—	—	4.20	—	
Low - Level Input Voltage	V _{IL}		2.0	—	—	0.50	—	0.50	V
			4.5	—	—	1.35	—	1.35	
			6.0	—	—	1.80	—	1.80	
High - Level Output Voltage	V _{OH}	V _{IN} = V _{IH} or V _{IL} I _{OH} = -20μA	2.0	1.9	2.0	—	1.9	—	V
			4.5	4.4	4.5	—	4.4	—	
			6.0	5.9	6.0	—	5.9	—	
		(DIR) (DOR)	4.5	4.18	4.31	—	4.13	—	
			6.0	5.68	5.80	—	5.63	—	
			Q0~Q3	4.5	4.18	4.31	—	4.13	
Low - Level Output Voltage	V _{OL}	V _{IN} = V _{IH} or V _{IL} I _{OL} = 20μA	2.0	—	0.0	0.1	—	0.1	V
			4.5	—	0.0	0.1	—	0.1	
			6.0	—	0.0	0.1	—	0.1	
		(DIR) (DOR)	4.5	—	0.17	0.26	—	0.33	
			6.0	—	0.18	0.26	—	0.33	
			Q0~Q3	4.5	—	0.17	0.26	—	
6.0	—	0.18	0.26	—	0.33				
3 - State Output Off - State Current	I _{OZ}	V _{IN} = V _{IH} or V _{IL} V _{OUT} = V _{CC} or GND	6.0	—	—	± 0.5	—	± 5.0	μA
Input Leakage Current	I _{IN}	V _{IN} = V _{CC} or GND	6.0	—	—	± 0.1	—	± 1.0	
Quiescent Supply Current	I _{CC}	V _{IN} = V _{CC} or GND	6.0	—	—	4.0	—	40.0	

TIMING REQUIREMENTS (Input $t_r = t_f = 6\text{ns}$)

PARAMETER	SYMBOL	TEST CONDITION	V_{CC} (V)	Ta = 25°C		Ta = -40-85°C	UNIT
				TYP.	LIMIT	LIMIT	
Minimum Pulse Width (SI)	$t_{W(L)}$ $t_{W(H)}$		2.0	—	75	95	ns
			4.5	—	15	19	
			6.0	—	13	16	
Minimum Pulse Width (\overline{SO})	$t_{W(L)}$ $t_{W(H)}$		2.0	—	75	95	
			4.5	—	15	19	
			6.0	—	13	16	
Minimum Pulse Width (MR)	$t_{W(L)}$ $t_{W(H)}$		2.0	—	75	95	
			4.5	—	15	19	
			6.0	—	13	16	
Minimum Set-up Time (DATA-SI)	t_s		2.0	—	0	0	
			4.5	—	0	0	
			6.0	—	0	0	
Minimum Hold Time (DATA-SI)	t_h		2.0	—	100	125	
			4.5	—	20	25	
			6.0	—	17	21	
Minimum Removal Time (MR-SI)	t_{rem}		2.0	—	50	65	
			4.5	—	10	13	
			6.0	—	9	11	
Clock Frequency	f		2.0	—	3	2.4	MHz
			4.5	—	15	12	
			6.0	—	18	13	

AC ELECTRICAL CHARACTERISTICS ($C_L = 15\text{pF}$, $V_{CC} = 5\text{V}$, Ta = 25°C, Input $t_r = t_f = 6\text{ns}$)

PARAMETER	SYMBOL	TEST CONDITION	MIN.	TYP.	MAX.	UNIT
Output Transition Time (DIR, DOR)	t_{TLH}		—	4	8	ns
	t_{THL}					
Propagation Delay Time (\overline{SO} , MR-DOR)	t_{pHL}		—	22	39	
Propagation Delay Time (\overline{SO} -DIR)	t_{pLH}		—	242	365	
Propagation Delay Time (SI-DOR)	t_{pLH}		—	187	300	
Propagation Delay Time (SI-DIR)	t_{pHL}		—	22	35	
Propagation Delay Time (MR-DIR)	t_{pLH} t_{pHL}		—	25	39	

AC ELECTRICAL CHARACTERISTICS (Input $t_r = t_f = 6\text{ns}$)

PARAMETER	SYMBOL	TEST CONDITION	CL (pF)	V _{CC} (V)	Ta = 25°C			Ta = -40~85°C		UNIT
					MIN.	TYP.	MAX.	MIN.	MAX.	
Output Transition Time (Q0~Q3)	t_{TLH} t_{THL}		50	2.0	—	21	60	—	75	ns
				4.5	—	7	12	—	15	
				6.0	—	6	10	—	13	
Output Transition Time (DIR, DOR)	t_{TLH} t_{THL}		50	2.0	—	24	75	—	95	
				4.5	—	8	15	—	19	
				6.0	—	7	13	—	16	
Propagation Delay Time (\overline{SO} , MR-DOR)	t_{pHL}		50	2.0	—	84	225	—	280	
				4.5	—	28	45	—	56	
				6.0	—	24	38	—	48	
Propagation Delay Time (\overline{SO} -DIR)	t_{pLH}		50	2.0	—	798	2000	—	2500	
				4.5	—	266	400	—	500	
				6.0	—	226	340	—	425	
Propagation Delay Time (SI-DOR)	t_{pLH}		50	2.0	—	624	1650	—	2060	
				4.5	—	208	330	—	412	
				6.0	—	177	280	—	350	
Propagation Delay Time (SI-DIR)	t_{pHL}		50	2.0	—	78	200	—	250	
				4.5	—	26	40	—	50	
				6.0	—	22	34	—	43	
Propagation Delay Time (\overline{SO} -Qn)	t_{pLH} t_{pHL}		50	2.0	—	156	400	—	500	
				4.5	—	52	80	—	100	
				6.0	—	44	68	—	85	
			150	2.0	—	171	440	—	550	
				4.5	—	57	88	—	110	
				6.0	—	48	75	—	94	
Propagation Delay Time (SI-Qn)	t_{pLH} t_{pHL}		50	2.0	—	612	1500	—	1875	
				4.5	—	204	300	—	375	
				6.0	—	173	255	—	319	
			150	2.0	—	627	1540	—	1925	
				4.5	—	209	308	—	385	
				6.0	—	178	262	—	327	
Propagation Delay Time (MR-DIR)	t_{pLH} t_{pHL}		50	2.0	—	87	225	—	280	
				4.5	—	29	45	—	56	
				6.0	—	25	38	—	48	
Output Enable time	t_{pZL} t_{pZH}	$R_L = 1\text{k}\Omega$	50	2.0	—	45	125	—	155	
				4.5	—	15	25	—	31	
				6.0	—	13	21	—	26	
			150	2.0	—	60	165	—	205	
				4.5	—	20	33	—	41	
				6.0	—	17	28	—	35	
Output Disable time	t_{pLZ} t_{pHZ}	$R_L = 1\text{k}\Omega$	50	2.0	—	32	125	—	155	
				4.5	—	16	25	—	31	
				6.0	—	14	21	—	26	

AC ELECTRICAL CHARACTERISTICS (Input $t_r = t_f = 6\text{ns}$) (Cont'd)

PARAMETER	SYMBOL	TEST CONDITION	CL (pF)	V _{CC} (V)	Ta = 25°C			Ta = -40-85°C		UNIT
					MIN.	TYP.	MAX.	MIN.	MAX.	
Maximum Clock Frequency	f _{MAX}		50	2.0	3	7	—	2.4	—	MHz
				4.5	15	22	—	12	—	
				6.0	18	26	—	14	—	
			150	2.0	2.6	6	—	2	—	
				4.5	13	20	—	10	—	
				6.0	15	24	—	12	—	
Output Pulse Width (DIR)	t _{w(H)} t _{w(L)}		50	2.0	—	95	—	—	ns	
				4.5	—	25	—	—		
				6.0	—	21	—	—		
Output Pulse Width (DOR)	t _{w(H)} t _{w(L)}		50	2.0	—	95	—	—	ns	
				4.5	—	25	—	—		
				6.0	—	21	—	—		
Input Capacitance	C _{IN}				—	5	10	—	10	pF
Output Capacitance	C _{OUT}				—	10	—	—	—	
Power Dissipation Capacitance	C _{PD}	Note (1)			—	300	—	—	—	

Note (1) C_{PD} is defined as the value of the internal equivalent capacitance which is calculated from the operating current consumption without load.

Average operating current can be obtained by the equation :

$$I_{CC}(\text{opr}) = C_{PD} \cdot V_{CC} \cdot f_{IN} + I_{CC}$$

DIP 16PIN PACKAGE DIMENSIONS (DIP16-P-300-2.54A)

Unit in mm

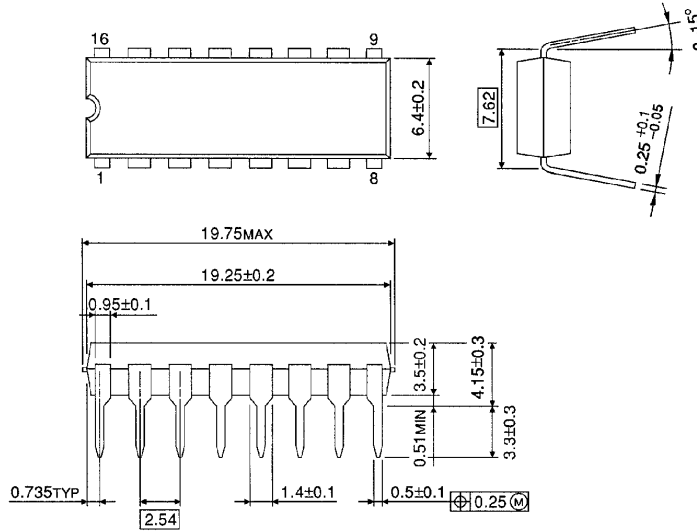

Weight : 1.00g (Typ.)

SOP 16PIN (200mil BODY) PACKAGE DIMENSIONS (SOP16-P-300-1.27)

Unit in mm

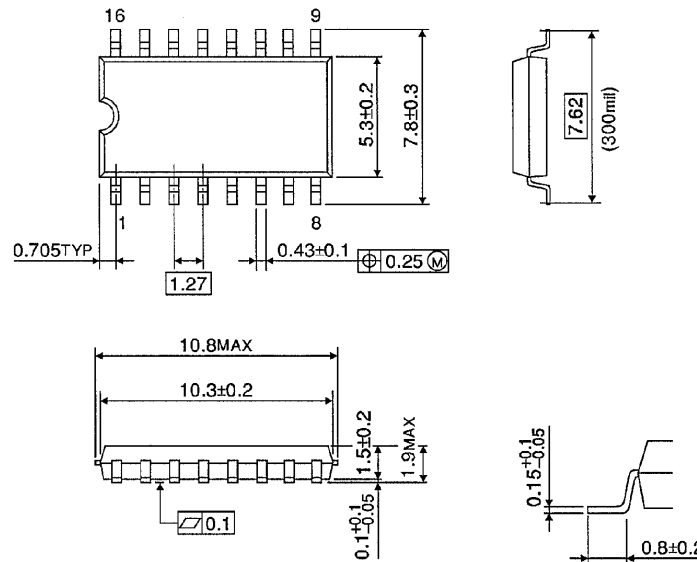

Weight : 0.18g (Typ.)