

TOSHIBA CMOS DIGITAL INTEGRATED CIRCUIT SILICON MONOLITHIC

TC74HCT652AP

OCTAL BUS TRANSCEIVER / REGISTER (3-STATE)

The TC74HCT652A is high speed CMOS OCTAL BUS TRANSCEIVER / REGISTER fabricated with silicon gate C²MOS technology.

It achieves the high speed operation similar to equivalent LSTTL while maintaining the CMOS low power dissipation. Its inputs are compatible with TTL, NMOS, and CMOS output voltage levels.

This device is bus transceiver with 3-state outputs, D-type flip-flops, and control circuitry arranged for multiplexed transmission of data directly from the internal registers.

ALL inputs are equipped with protection circuits against static discharge or transient excess voltage.

FEATURES :

- High Speed..... $f_{MAX} = 60 \text{ MHz (typ.)}$
at $V_{CC} = 5V$
- Low Power Dissipation..... $I_{CC} = 4\mu\text{A (Max.)}$ at $T_a = 25^\circ\text{C}$
- Compatible with TTL Output..... $V_{IH} = 2.0V \text{ (Min.)}$
 $V_{IL} = 0.8V \text{ (Max.)}$
- Output Drive Capability..... 15 LSTTL Loads
- Symmetrical Output Impedance... $|I_{OH}| = I_{OL} = 6\text{mA (Min.)}$
- Balanced Propagation Delays..... $t_{PLH} \approx t_{PHL}$
- Pin and Function Compatible with 74LS652

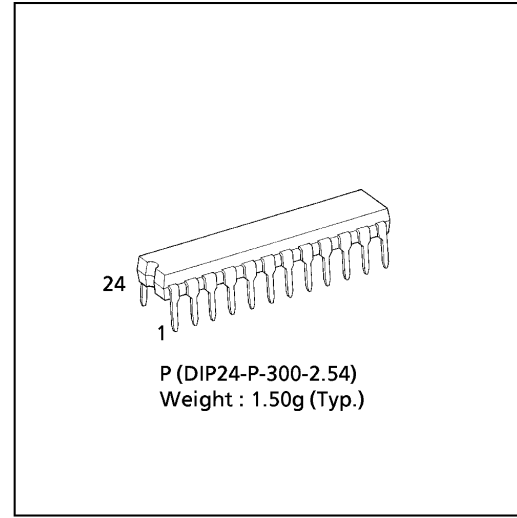

PIN ASSIGNMENT

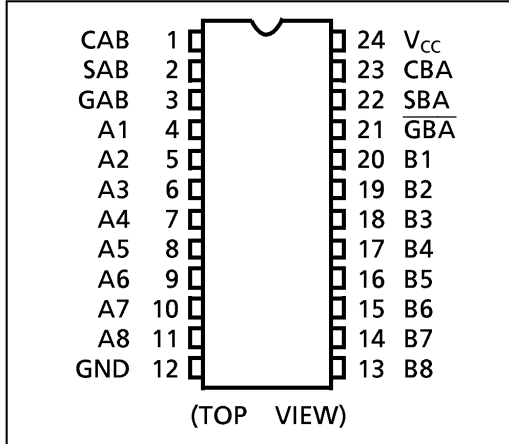

IEC LOGIC SYMBOL

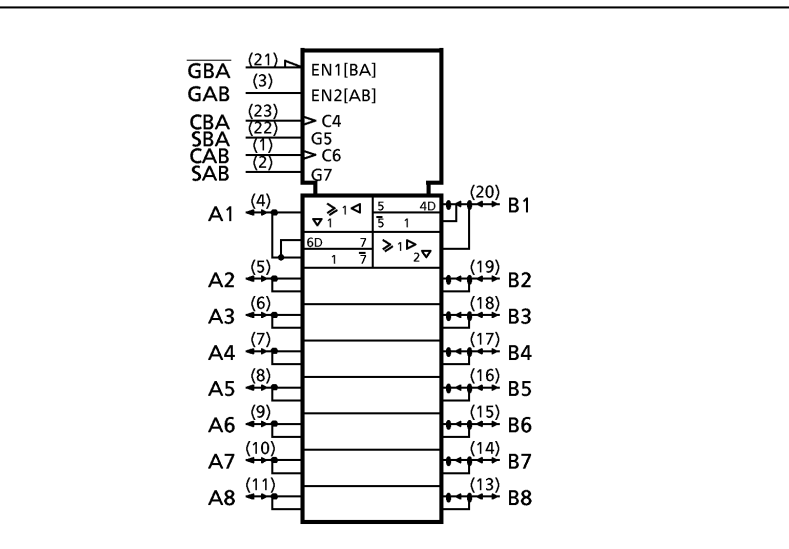







APPLICATION NOTES

- 1) Do not apply a signal to any bus terminal when it is in the out put mode. Damage may result.
- 2) All floating (high impedance) bus terminals must have their input levels fixed by means of pull up or pull down resistors.

961001EBA2

● TOSHIBA is continually working to improve the quality and the reliability of its products. Nevertheless, semiconductor devices in general can malfunction or fail due to their inherent electrical sensitivity and vulnerability to physical stress. It is the responsibility of the buyer, when utilizing TOSHIBA products, to observe standards of safety, and to avoid situations in which a malfunction or failure of a TOSHIBA product could cause loss of human life, bodily injury or damage to property. In developing your designs, please ensure that TOSHIBA products are used within specified operating ranges as set forth in the most recent products specifications. Also, please keep in mind the precautions and conditions set forth in the TOSHIBA Semiconductor Reliability Handbook.

TRUTH TABLE

GAB	\overline{GBA}	CAB	CBA	SAB	SBA	A	B	Function
L	H	X*	X*	X	X	INPUTS Z	INPUTS Z	The output functions of A and B Busses are disabled.
				X	X	X	X	Both A and B Busses are used as inputs to the internal flip-flops. Data on the Bus will be stored on the rising edge of the Clock.
H	H	X*	X*	L	X	INPUTS L H	OUTPUTS L H	The data on the A bus are displayed on the B bus.
			X*	L	X	L H	L H	The data on the A Bus are displayed on the B Bus, and are stored into the A storage flip-flops on the rising edge of CAB.
		X*	X*	H	X	X	Qn	The data in the A storage flip-flops are displayed on the B Bus.
			X*	H	X	L H	L H	The data on the A Bus are stored into the A storage flip-flops on the rising edge of CAB, and the stored data propagate directly onto the B Bus.
L	L	X*	X*	X	L	OUTPUTS L H	INPUTS L H	The data on the B bus are displayed on the A bus.
		X*		X	L	L H	L H	The data on the B Bus are displayed on the A Bus, and are stored into the B storage flip-flops on the rising edge of CBA.
		X*	X*	X	H	Qn	X	The data in the B storage flip-flops are displayed on the A Bus.
		X*		X	H	L H	L H	The data on the B Bus are stored into the B storage flip-flops on the rising edge of CBA, and the stored data propagate directly onto the A Bus.
H	L	X*	X*	H	H	OUTPUTS Qn	OUTPUTS Qn	The data stored to the internal flip-flops are displayed at the A and B bus respectively.

Notes: X : Don't Care

Qn : The data stored into the internal flip-flops by most recent low to high transition of the clock inputs.

Z : High Impedance

* : The clock are not internally gated with either GAB or \overline{GBA} . Therefore, data on the A and/or B Busses may be clocked into the storage flip-flops at any time.

961001EBA2'

- The products described in this document are subject to foreign exchange and foreign trade control laws.
- The information contained herein is presented only as a guide for the applications of our products. No responsibility is assumed by TOSHIBA CORPORATION for any infringements of intellectual property or other rights of the third parties which may result from its use. No license is granted by implication or otherwise under any intellectual property or other rights of TOSHIBA CORPORATION or others.
- The information contained herein is subject to change without notice.

TIMING CHART

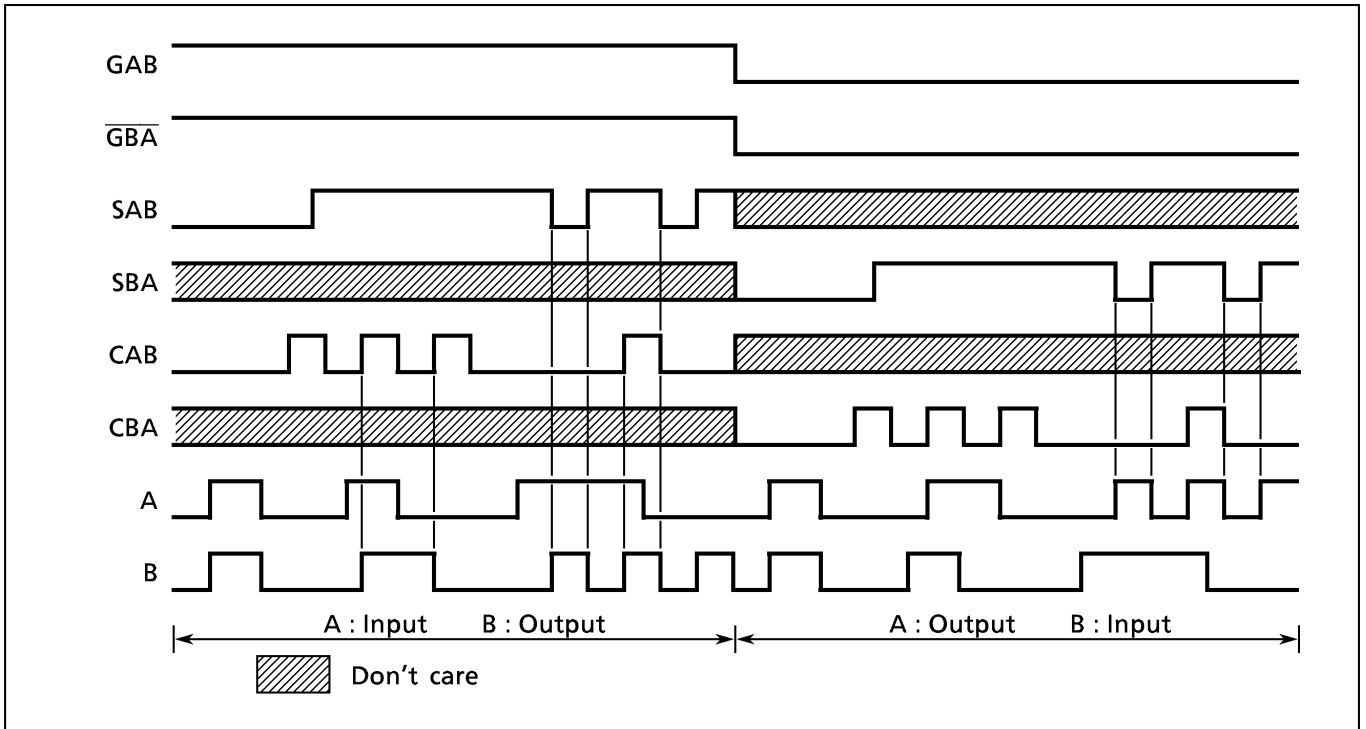

SYSTEM DIAGRAM

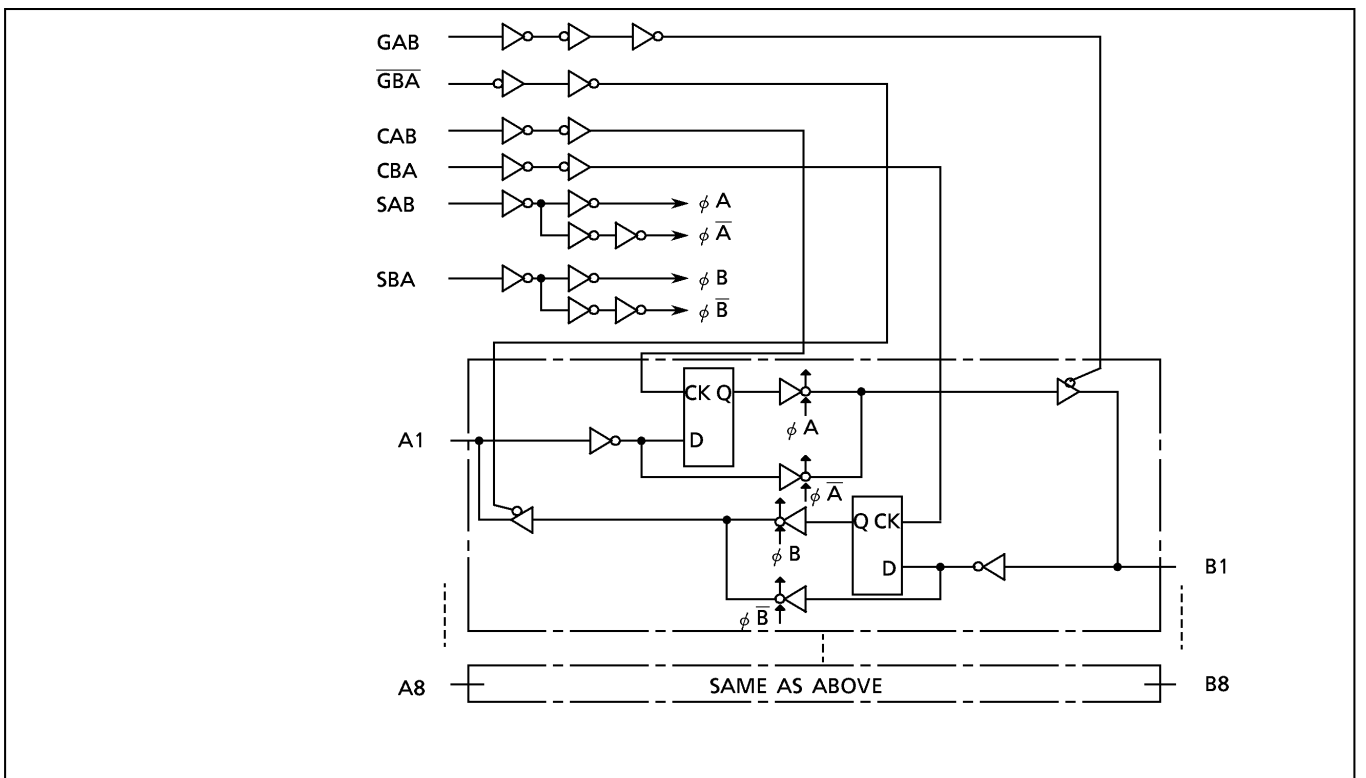

ABSOLUTE MAXIMUM RATINGS

PARAMETER	SYMBOL	VALUE	UNIT
Supply Voltage Range	V_{CC}	-0.5~7.0	V
DC Input Voltage	V_{IN}	-0.5~ $V_{CC} + 0.5$	V
DC Output Voltage	V_{OUT}	-0.5~ $V_{CC} + 0.5$	V
Input Diode Current	I_{IK}	±20	mA
Output Diode Current	I_{OK}	±20	mA
DC Output Current	I_{OUT}	±35	mA
DC V_{CC} /Ground Current	I_{CC}	±75	mA
Power Dissipation	P_D	500 (DIP)*	mW
Storage Temperature	T_{stg}	-65~150	°C

*500mW in the range of $T_a = -40^{\circ}\text{C} \sim 65^{\circ}\text{C}$. From $T_a = 65^{\circ}\text{C}$ to 85°C a derating factor of $-10\text{mW}/^{\circ}\text{C}$ should be applied up to 300mW.

RECOMMENDED OPERATING CONDITIONS

PARAMETER	SYMBOL	VALUE	UNIT
Supply Voltage	V_{CC}	4.5~5.5	V
Input Voltage	V_{IN}	0~ V_{CC}	V
Output Voltage	V_{OUT}	0~ V_{CC}	V
Operating Temperature	T_{opr}	-40~85	°C
Input Rise and Fall Time	t_r, t_f	0~500	ns

DC ELECTRICAL CHARACTERISTICS

PARAMETER	SYMBOL	TEST CONDITION	V_{CC} (V)	$T_a = 25^{\circ}\text{C}$			$T_a = -40 \sim 85^{\circ}\text{C}$		UNIT	
				MIN.	TYP.	MAX.	MIN.	MAX.		
High - Level Input Voltage	V_{IH}		4.5 ┆ 5.5	2.0	—	—	2.0	—	V	
Low - Level Input Voltage	V_{IL}		4.5 ┆ 5.5	—	—	0.8	—	0.8	V	
High - Level Output Voltage	V_{OH}	$V_{IN} = V_{IH}$ or V_{IL}	$I_{OH} = -20 \mu\text{A}$	4.5	4.4	4.5	—	4.4	—	V
			$I_{OH} = -6 \text{ mA}$	4.5	4.18	4.31	—	4.13	—	V
Low - Level Output Voltage	V_{OL}	$V_{IN} = V_{IH}$ or V_{IL}	$I_{OL} = 20 \mu\text{A}$	4.5	—	0.0	0.1	—	0.1	V
			$I_{OL} = 6 \text{ mA}$	4.5	—	0.17	0.26	—	0.33	V
3 - State Output Off - State Current	I_{OZ}	$V_{IN} = V_{IH}$ or V_{IL} $V_{OUT} = V_{CC}$ or GND	5.5	—	—	±0.5	—	±5.0	μA	
Input Leakage Current	I_{IN}	$V_{IN} = V_{CC}$ or GND	5.5	—	—	±0.1	—	±1.0	μA	
Quiescent Supply Current	I_{CC}	$V_{IN} = V_{CC}$ or GND	5.5	—	—	4.0	—	40.0	μA	
	I_C	Per input: $V_{IN} = 0.5\text{V}$ or 2.4V Other input: V_{CC} or GND	5.5	—	—	2.0	—	2.9	mA	

TIMING REQUIREMENTS (Input $t_r = t_f = 6ns$)

PARAMETER	SYMBOL	TEST CONDITION	Ta = 25°C			Ta = -40~85°C	UNIT
			V _{CC} (V)	TYP.	LIMIT	LIMIT	
Minimum Pulse Width (CK)	$t_{W(L)}$ $t_{W(H)}$		4.5	—	15	19	ns
			5.5	—	14	17	
Minimum Set-up Time	t_s		4.5	—	10	13	
			5.5	—	9	12	
Minimum Hold Time	t_h		4.5	—	5	5	
			5.5	—	5	5	
Clock Frequency	f		4.5	—	31	25	MHz
			5.5	—	37	30	

AC ELECTRICAL CHARACTERISTICS (Input $t_r = t_f = 6ns$)

PARAMETER	SYMBOL	TEST CONDITION			Ta = 25°C			Ta = -40~85°C		UNIT
			CL (pF)	V _{CC} (V)	MIN.	TYP.	MAX.	MIN.	MAX.	
Output Transition Time	t_{TLH} t_{THL}		50	4.5	—	7	12	—	15	ns
				5.5	—	6	11	—	14	
Propagation Delay Time (BUS-BUS)	t_{pLH}		50	4.5	—	20	30	—	38	
				5.5	—	17	27	—	34	
	t_{pHL}		150	4.5	—	25	38	—	48	
				5.5	—	22	34	—	43	
Propagation Delay Time (CAB, CBA-BUS)	t_{pLH}		50	4.5	—	29	44	—	55	
				5.5	—	26	40	—	50	
	t_{pHL}		150	4.5	—	34	52	—	65	
				5.5	—	31	47	—	59	
Propagation Delay Time (SAB, SBA-BUS)	t_{pLH}		50	4.5	—	24	34	—	43	
				5.5	—	21	31	—	39	
	t_{pHL}		150	4.5	—	29	42	—	53	
				5.5	—	26	38	—	48	
Output Enable Time (GAB, $\overline{G}BA$ -BUS)	t_{pZL}	$R_L = 1k\Omega$	50	4.5	—	22	33	—	41	
				5.5	—	20	30	—	37	
	t_{pZH}		150	4.5	—	27	41	—	51	
				5.5	—	24	37	—	46	
Output Enable Time (GAB, $\overline{G}BA$ -BUS)	t_{pLZ} t_{pHZ}	$R_L = 1k\Omega$	50	4.5	—	24	35	—	44	
				5.5	—	22	32	—	40	
Maximum Clock Frequency	f _{MAX}		50	4.5	31	55	—	25	—	MHz
				5.5	37	61	—	30	—	
Input Capacitance	C _{IN}	GAB, $\overline{G}BA$, SAB, SBA, CAB, CBA			—	5	10	—	10	pF
Output Capacitance	C _{OUT}	An, Bn			—	13	—	—	—	
Power Dissipation Capacitance	C _{PD} (1)				—	39	—	—	—	

Note(1): C_{PD} is defined as the value of the internal equivalent capacitance which is calculated from the operating current consumption without load.

Average operating current can be obtained by the equation :

$$I_{CC}(\text{opr}) = C_{PD} \cdot V_{CC} \cdot f_{IN} + I_{CC} / 8 \text{ (per bit)}$$

DIP 24PIN OUTLINE DRAWING (DIP24-P-300-2.54)

Unit in mm

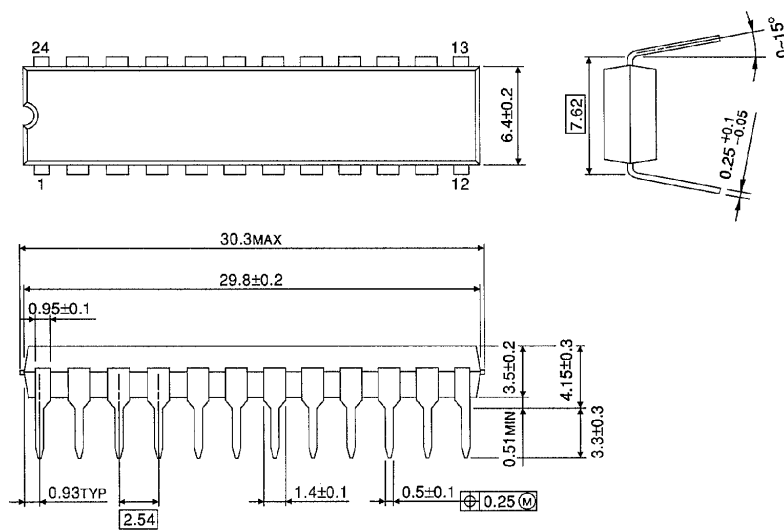

Weight : 1.50g (Typ.)