



GENERAL DESCRIPTION



The ICS8535-01 is a low skew, high performance 1-to-4 LVC MOS-to-3.3V LVPECL fanout buffer and a member of the HiPerClockS™ family of High Performance Clock Solutions from ICS. The ICS8535-01 has two single ended clock inputs.

The single ended clock input accepts LVC MOS or LVTTTL input levels and translate them to 3.3V LVPECL levels. The clock enable is internally synchronized to eliminate runt clock pulses on the output during asynchronous assertion/deassertion of the clock enable pin.

Guaranteed output and part-to-part skew characteristics make the ICS8535-01 ideal for those applications demanding well defined performance and repeatability.

FEATURES

- 4 differential 3.3V LVPECL outputs
- Selectable CLK0 or CLK1 inputs for redundant and multiple frequency fanout applications
- CLK0 or CLK1 can accept the following differential input levels: LVC MOS or LVTTTL
- Maximum output frequency up to 266MHz
- Translates LVC MOS and LVTTTL levels to 3.3V LVPECL levels
- Output skew: 30ps (maximum)
- Part-to-part skew: 150ps (maximum)
- Propagation delay: 1.9ns (maximum)
- 3.3V operating supply
- 0°C to 70°C ambient operating temperature
- Industrial temperature information available upon request

BLOCK DIAGRAM

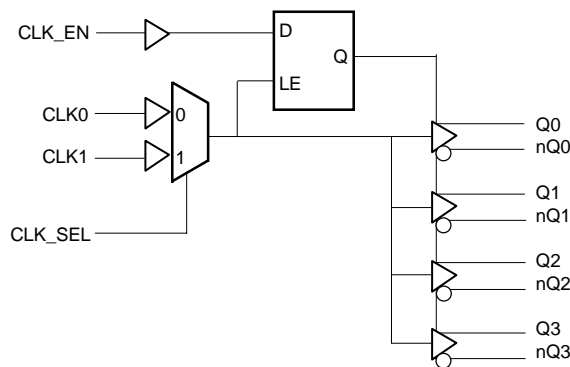

PIN ASSIGNMENT

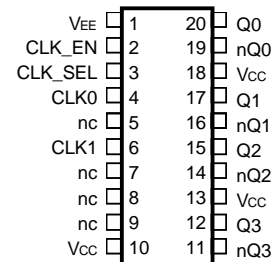

ICS8535-01
20-Lead TSSOP
4.4mm x 6.5mm x 0.92mm body package
G Package
Top View



TABLE 1. PIN DESCRIPTIONS

Number	Name	Type		Description
1	V _{EE}	Power		Negative supply pin. Connect to ground.
2	CLK_EN	Input	Pullup	Synchronizing clock enable. When HIGH, clock outputs follow clock input. When LOW, Q outputs are forced low, nQ outputs are forced high. LVCMOS / LVTTTL interface levels.
3	CLK_SEL	Input	Pulldown	Clock select input. When HIGH, selects CLK1 input. When LOW, selects CLK0 input. LVCMOS / LVTTTL interface levels.
4	CLK0	Input	Pulldown	LVCMOS / LVTTTL clock input.
6	CLK1	Input	Pulldown	LVCMOS / LVTTTL clock input.
5, 7, 8, 9	nc	Unused		No connect.
10, 13, 18	V _{CC}	Power		Positive supply pins. Connect to 3.3V.
11, 12	nQ3, Q3	Output		Differential output pair. LVPECL interface levels.
14, 15	nQ2, Q2	Output		Differential output pair. LVPECL interface levels.
16, 17	nQ1, Q1	Output		Differential output pair. LVPECL interface levels.
19, 20	nQ0, Q0	Output		Differential output pair. LVPECL interface levels.

NOTE: *Pullup* and *Pulldown* refers to internal input resistors. See Table 2, Pin Characteristics, for typical values.

TABLE 2. PIN CHARACTERISTICS

Symbol	Parameter	Test Conditions	Minimum	Typical	Maximum	Units
C _{IN}	Input Capacitance	CLK0, CLK1			4	pF
		CLK_EN, CLK_SEL			4	pF
R _{PULLUP}	Input Pullup Resistor			51		KΩ
R _{PULLDOWN}	Input Pulldown Resistor			51		KΩ



TABLE 3A. CONTROL INPUT FUNCTION TABLE

Inputs			Outputs	
CLK_EN	CLK_SEL	Selected Source	Q0 thru Q3	nQ0 thru nQ3
0	0	CLK0	Disabled; LOW	Disabled; HIGH
0	1	CLK1	Disabled; LOW	Disabled; HIGH
1	0	CLK0	Enabled	Enabled
1	1	CLK1	Enabled	Enabled

After CLK_EN switches, the clock outputs are disabled or enabled following a rising and falling input clock edge as show in Figure 1.

In the active mode, the state of the outputs are a function of the CLK0 and CLK1 inputs as described in Table 3B.

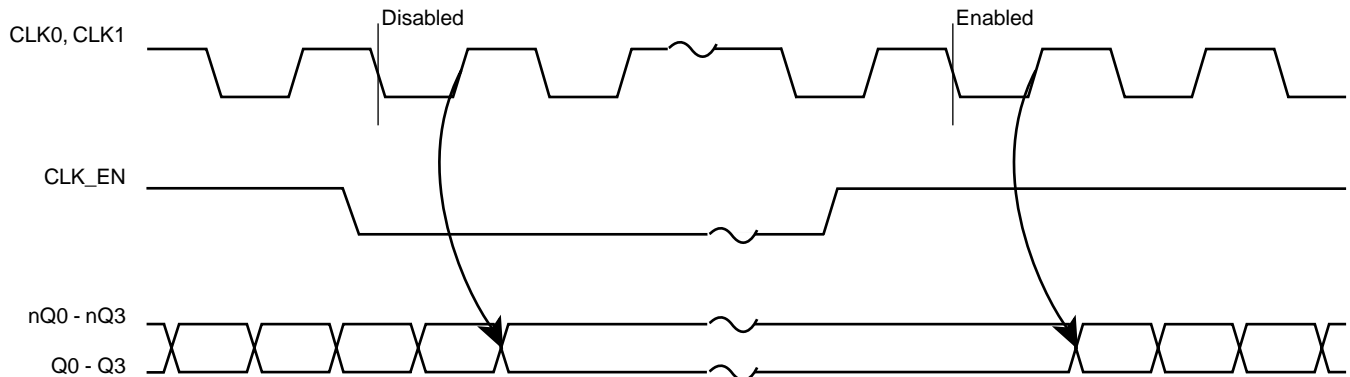

FIGURE 1 - CLK_EN TIMING DIAGRAM

TABLE 3B. CLOCK INPUT FUNCTION TABLE

Inputs	Outputs	
CLK0 or CLK1	Q0 thru Q3	nQ0 thru nQ3
0	LOW	HIGH
1	HIGH	LOW



ABSOLUTE MAXIMUM RATINGS

Supply Voltage, V_{CCx}	4.6V
Inputs, V_I	-0.5V to $V_{CC} + 0.5V$
Outputs, V_O	-0.5V to $V_{CC} + 0.5V$
Package Thermal Impedance, θ_{JA}	73.2°C/W (no airflow)
Storage Temperature, T_{STG}	-65°C to 150°C

Stresses beyond those listed under Absolute Maximum Ratings may cause permanent damage to the device. These ratings are stress specifications only. Functional operation of product at these conditions or any conditions beyond those listed in the *DC Characteristics* or *AC Characteristics* is not implied. Exposure to absolute maximum rating conditions for extended periods may affect product reliability.

TABLE 4A. POWER SUPPLY DC CHARACTERISTICS, $V_{CC} = 3.3V \pm 5\%$, $T_A = 0^\circ C$ TO $70^\circ C$

Symbol	Parameter	Test Conditions	Minimum	Typical	Maximum	Units
V_{CC}	Positive Supply Voltage		3.135	3.3	3.465	V
I_{EE}	Power Supply Current				50	mA

TABLE 4B. LVCMOS / LVTTTL DC CHARACTERISTICS, $V_{CC} = 3.3V \pm 5\%$, $T_A = 0^\circ C$ TO $70^\circ C$

Symbol	Parameter	Test Conditions	Minimum	Typical	Maximum	Units
V_{IH}	Input High Voltage	CLK0, CLK1	2		3.765	V
		CLK_EN, CLK_SEL	2		3.765	V
V_{IL}	Input Low Voltage	CLK0, CLK1	-0.3		1.3	V
		CLK_EN, CLK_SEL	-0.3		0.8	V
I_{IH}	Input High Current	CLK0, CLK1, CLK_SEL $V_{IN} = V_{CC} = 3.465V$			150	μA
		CLK_EN $V_{IN} = V_{CC} = 3.465V$			5	μA
I_{IL}	Input Low Current	CLK0, CLK1, CLK_SEL $V_{IN} = 0V, V_{CC} = 3.465V$	-5			μA
		CLK_EN $V_{IN} = 0V, V_{CC} = 3.465V$	-150			μA

TABLE 4C. LVPECL DC CHARACTERISTICS, $V_{CC} = 3.3V \pm 5\%$, $T_A = 0^\circ C$ TO $70^\circ C$

Symbol	Parameter	Test Conditions	Minimum	Typical	Maximum	Units
V_{OH}	Output High Voltage; NOTE 1		$V_{CC} - 1.4$		$V_{CC} - 1.0$	V
V_{OL}	Output Low Voltage; NOTE 1		$V_{CC} - 2.0$		$V_{CC} - 1.7$	V
V_{SWING}	Peak-to-Peak Output Voltage Swing		0.6		0.85	V

NOTE 1: Outputs terminated with 50Ω to $V_{CC} - 2V$.



TABLE 5. AC CHARACTERISTICS, $V_{CC} = 3.3V \pm 5\%$, $T_A = 0^\circ C$ TO $70^\circ C$

Symbol	Parameter	Test Conditions	Minimum	Typical	Maximum	Units
f_{MAX}	Maximum Output Frequency				266	MHz
t_{PD}	Propagation Delay; NOTE 1	$f \leq 266MHz$	1.0		1.9	ns
$t_{sk(o)}$	Output Skew; NOTE 2, 4			11	30	ps
$t_{sk(pp)}$	Part-to-Part Skew; NOTE 3, 4				150	ps
t_R	Output Rise Time	20% to 80% @ 50MHz	300		700	ps
t_F	Output Fall Time	20% to 80% @ 50MHz	300		700	ps
odc	Output Duty Cycle		48	50	52	%

All parameters measured at 266MHz unless noted otherwise.

The cycle-to-cycle jitter on the input will equal the jitter on the output. The part does not add jitter.

NOTE 1: Measured from the 50% point of the input to the differential output crossing point.

NOTE 2: Defined as skew between outputs at the same supply voltage and with equal load conditions.

Measured at the output differential cross points.

NOTE 3: Defined as skew between outputs on different devices operating at the same supply voltages and with equal load conditions. Using the same type of inputs on each device, the outputs are measured at the differential cross points.

NOTE 4: This parameter is defined in accordance with JEDEC Standard 65.



PARAMETER MEASUREMENT INFORMATION

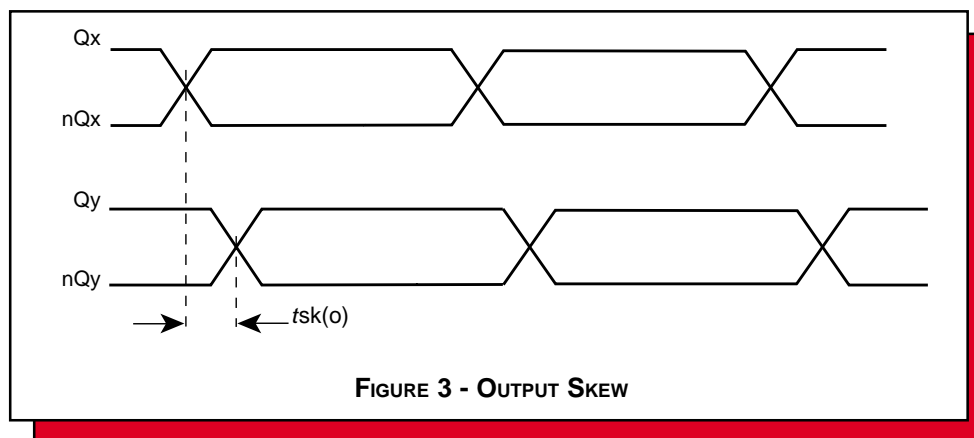
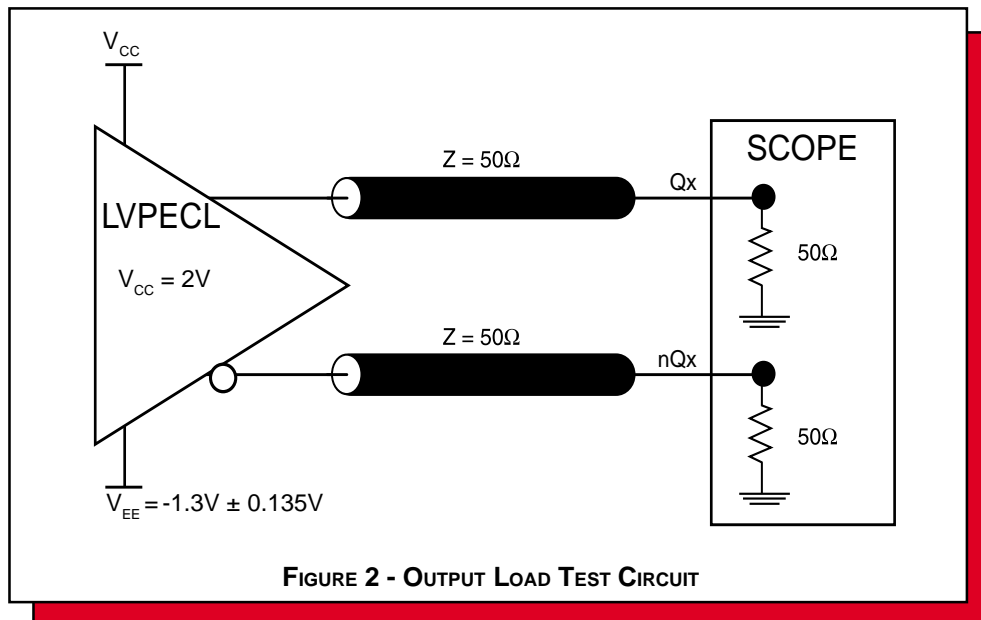

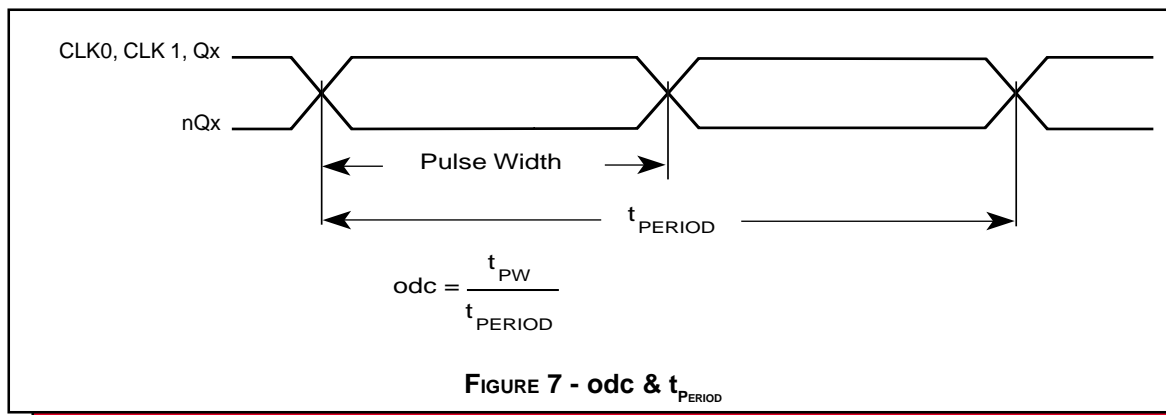
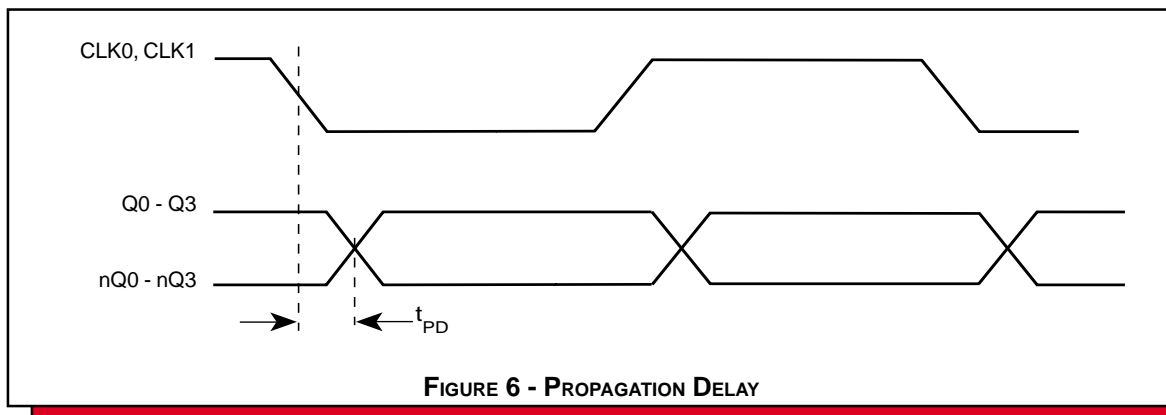
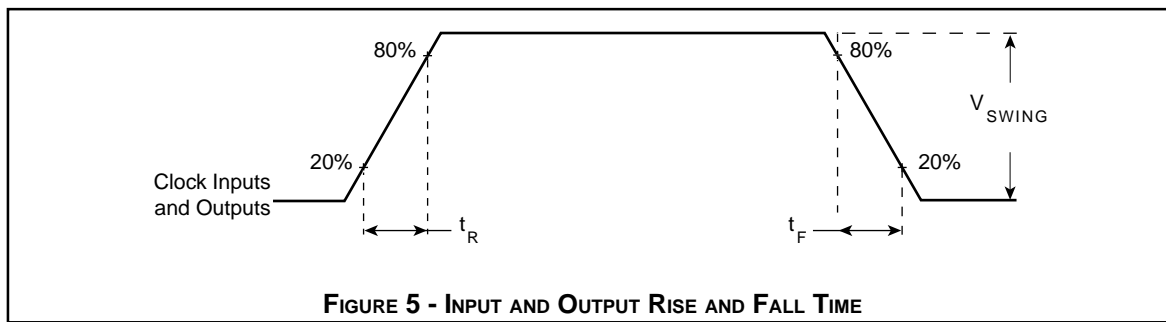
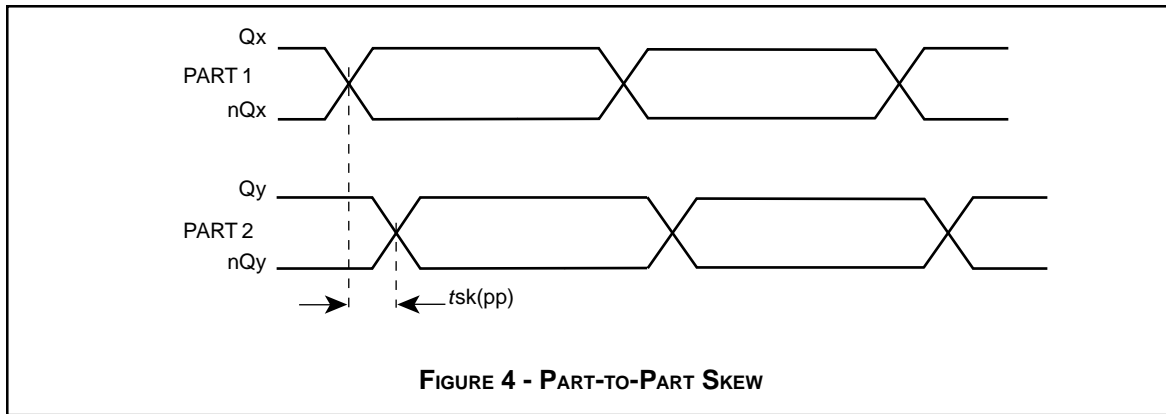



POWER CONSIDERATIONS

This section provides information on power dissipation and junction temperature for the ICS8535-01. Equations and example calculations are also provided.

1. Power Dissipation.

The total power dissipation for the ICS8535-01 is the sum of the core power plus the power dissipated in the load(s). The following is the power dissipation for $V_{CC} = 3.3V + 5\% = 3.465V$, which gives worst case results.

NOTE: Please refer to Section 3 for details on calculating power dissipated in the load.

- Power (core)_{MAX} = $V_{CC_MAX} * I_{EE_MAX} = 3.465V * 50mA = 173.25mW$
- Power (outputs)_{MAX} = **30.2mW/Loaded Output pair**
If all outputs are loaded, the total power is $4 * 30.2mW = 120.8mW$

$$\text{Total Power}_{MAX} (3.465V, \text{ with all outputs switching}) = 173.25mW + 120.8mW = \mathbf{294.05mW}$$

2. Junction Temperature.

Junction temperature, T_j , is the temperature at the junction of the bond wire and bond pad and directly affects the reliability of the device. The maximum recommended junction temperature for HiPerClockS™ devices is 125°C.

The equation for T_j is as follows: $T_j = \theta_{JA} * Pd_total + T_A$

T_j = Junction Temperature

θ_{JA} = junction-to-ambient thermal resistance

Pd_total = Total device power dissipation (example calculation is in section 1 above)

T_A = Ambient Temperature

In order to calculate junction temperature, the appropriate junction-to-ambient thermal resistance θ_{JA} must be used. Assuming a moderate air flow of 200 linear feet per minute and a multi-layer board, the appropriate value is 66.6°C/W per Table 6 below.

Therefore, T_j for an ambient temperature of 70°C with all outputs switching is:

$$70^\circ C + 0.294W * 66.6^\circ C/W = 89.58^\circ C. \text{ This is well below the limit of } 125^\circ C$$

This calculation is only an example, and the T_j will obviously vary depending on the number of outputs that are loaded, supply voltage, air flow, and the type of board (single layer or multi-layer).

Table 6. Thermal Resistance θ_{JA} for 20-pin TSSOP, Forced Convection

θ_{JA} by Velocity (Linear Feet per Minute)			
	0	200	500
Single-Layer PCB, JEDEC Standard Test Boards	114.5°C/W	98.0°C/W	88.0°C/W
Multi-Layer PCB, JEDEC Standard Test Boards	73.2°C/W	66.6°C/W	63.5°C/W

NOTE: Most modern PCB designs use multi-layered boards. The data in the second row pertains to most designs.



3. Calculations and Equations.

The purpose of this section is to derive the power dissipated into the load.

LVPECL output driver circuit and termination are shown in *Figure 8*.

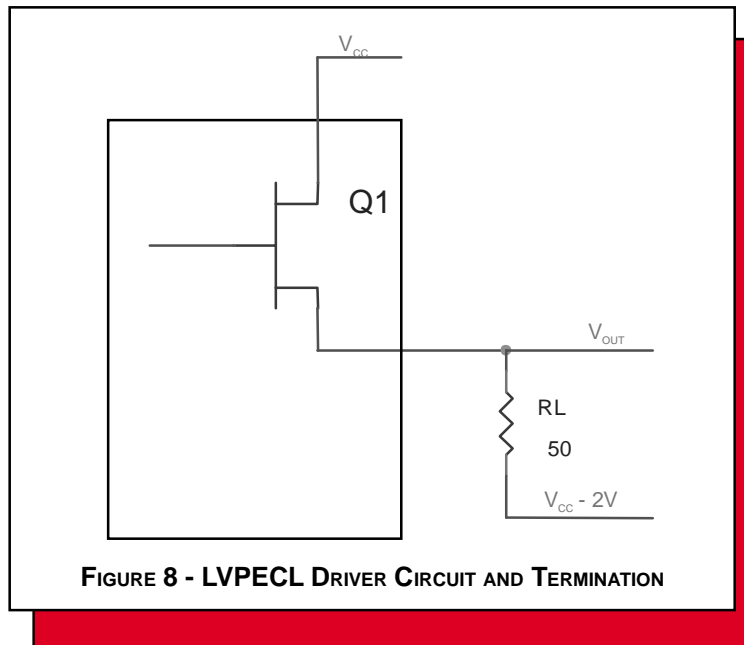

To calculate worst case power dissipation into the load, use the following equations which assume a 50Ω load, and a termination voltage of $V_{CC} - 2V$.

Pd_H is power dissipation when the output drives high.

Pd_L is the power dissipation when the output drives low.

$$Pd_H = [(V_{OH_MAX} - (V_{CC_MAX} - 2V))/R_L] * (V_{CC_MAX} - V_{OH_MAX})$$

$$Pd_L = [(V_{OL_MAX} - (V_{CC_MAX} - 2V))/R_L] * (V_{CC_MAX} - V_{OL_MAX})$$

- For logic high, $V_{OUT} = V_{OH_MAX} = V_{CC_MAX} - 1.0V$
Using $V_{CC_MAX} = 3.465$, this results in $V_{OH_MAX} = 2.465V$
- For logic low, $V_{OUT} = V_{OL_MAX} = V_{CC_MAX} - 1.7V$
Using $V_{CC_MAX} = 3.465$, this results in $V_{OL_MAX} = 1.765V$

$$Pd_H = [(2.465V - (3.465V - 2V))/50 \Omega] * (3.465V - 2.465V) = 20mW$$

$$Pd_L = [(1.765V - (3.465V - 2V))/50 \Omega] * (3.465V - 1.765V) = 10.2mW$$

$$\text{Total Power Dissipation per output pair} = Pd_H + Pd_L = 30.2mW$$



RELIABILITY INFORMATION

TABLE 7. θ_{JA} vs. AIR FLOW TABLE

θ_{JA} by Velocity (Linear Feet per Minute)			
	0	200	500
Single-Layer PCB, JEDEC Standard Test Boards	114.5°C/W	98.0°C/W	88.0°C/W
Multi-Layer PCB, JEDEC Standard Test Boards	73.2°C/W	66.6°C/W	63.5°C/W

NOTE: Most modern PCB designs use multi-layered boards. The data in the second row pertains to most designs.

TRANSISTOR COUNT

The transistor count for ICS8535-01 is: 412



PACKAGE OUTLINE - G SUFFIX

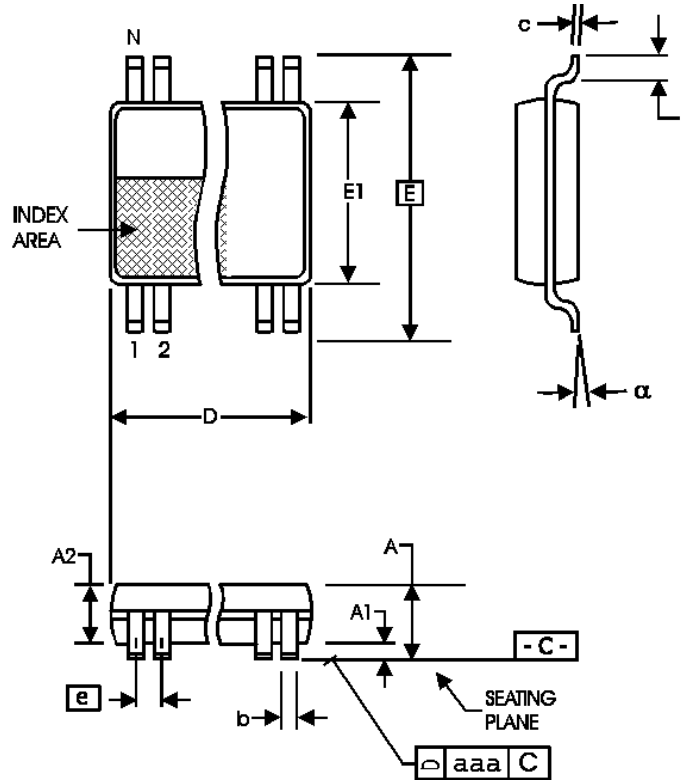

TABLE 8. PACKAGE DIMENSIONS

SYMBOL	Millimeters	
	MIN	MAX
N	20	
A	--	1.20
A1	0.05	0.15
A2	0.80	1.05
b	0.19	0.30
c	0.09	0.20
D	6.40	6.60
E	6.40 BASIC	
E1	4.30	4.50
e	0.65 BASIC	
L	0.45	0.75
alpha	0°	8°
aaa	--	0.10

REFERENCE DOCUMENT: JEDEC PUBLICATION 95, MO-153



Integrated
Circuit
Systems, Inc.

ICS8535-01
LOW SKEW, 1-TO-4
LVCMOS-TO-3.3V LVPECL FANOUT BUFFER

TABLE 9. ORDERING INFORMATION

Part/Order Number	Marking	Package	Count	Temperature
ICS8535AG-01	ICS8535AG-01	20 lead TSSOP	72 per tube	0°C to 70°C
ICS8535AG-01T	ICS8535AG-01	20 lead TSSOP on Tape and Reel	2500	0°C to 70°C

While the information presented herein has been checked for both accuracy and reliability, Integrated Circuit Systems, Incorporated (ICS) assumes no responsibility for either its use or for infringement of any patents or other rights of third parties, which would result from its use. No other circuits, patents, or licenses are implied. This product is intended for use in normal commercial applications. Any other applications such as those requiring extended temperature range, high reliability, or other extraordinary environmental requirements are not recommended without additional processing by ICS. ICS reserves the right to change any circuitry or specifications without notice. ICS does not authorize or warrant any ICS product for use in life support devices or critical medical instruments.