

### **3. S3C1860**

## DESCRIPTION

S3C1860, a 4-bit single-chip CMOS microcontroller, consists of the reliable SMCS-51 CPU core with on-chip ROM and RAM.

The S3C1860 is the microcontroller which has 1024 bytes mask-programmable ROM.

The S3P1860 is the microcontroller which has 1024 bytes one-time-programmable EPROM. In the S3P1860, the oscillator frequency divide option is not offered and  $F_{osc}/8$  is only used for the system clock (fxx).

It provides 6 input pins and 9 output pins. Auto reset circuit generates reset pulse every certain period, and every halt mode termination time. The S3C1860 microcontroller has been designed for use in small system control applications that require a low-power, cost-sensitive design solution. In addition, the S3C1860 has been optimized for remote control transmitter and has built-in Transistor for I.R.LED drive.

## FEATURES

### ROM Size

- 1,024 bytes

### RAM Size

- 32 nibbles

### Instruction Set

- 39 instructions

### Instruction Cycle Time

- 13.2  $\mu$ sec at fxx = 455 kHz

### Input Ports

- One 4-bit, One 2-bit ports

### Output Ports

- One 4-bit, Five 1-bit ports

### Built-in Oscillator

- Crystal/Ceramic resonator

### Built-in Reset Circuit

- Oscillation Start and Reset (OSR) circuit
- Auto-Reset circuit for generating reset pulse every  $13.1072/f_{xx}$  (288 ms at fxx = 455 kHz)
- Reset circuit with HALT mode releasing

### Four Transmission Frequencies

- fxx/12 (1/4 duty), fxx/12 (1/3 duty), fxx/8 (1/2 duty), and no-carrier frequency

### Built-in Transistor for I.R.LED Drive

- $I_{OL1}$ : 280 mA (typical) at  $V_{DD} = 3V$  and  $V_O = 0.4V$

### Supply Voltage

- 1.8 V-3.6 V ( $250 \text{ kHz} \leq f_{OSC} \leq 3.9 \text{ MHz}$ )
- 2.2 V-3.6 V ( $3.9 \text{ MHz} < f_{OSC} \leq 6 \text{ MHz}$ )

### Power Consumption

- Halt mode: 1  $\mu$ A (maximum)
- Normal mode: 0.5 mA (typical)

### Operating temperature

- -20 °C to 85 °C

### Package Type

- 20 DIP, 20 SOP

### Oscillator Frequency divide select

- Mask Option : fxx =  $f_{OSC}$  or  $f_{OSC}/8$

### Oscillation Start and Reset (OSR) circuit

- A system reset pulse occurs when the chip is in non-operating voltage with oscillation.

BLOCK DIAGRAM

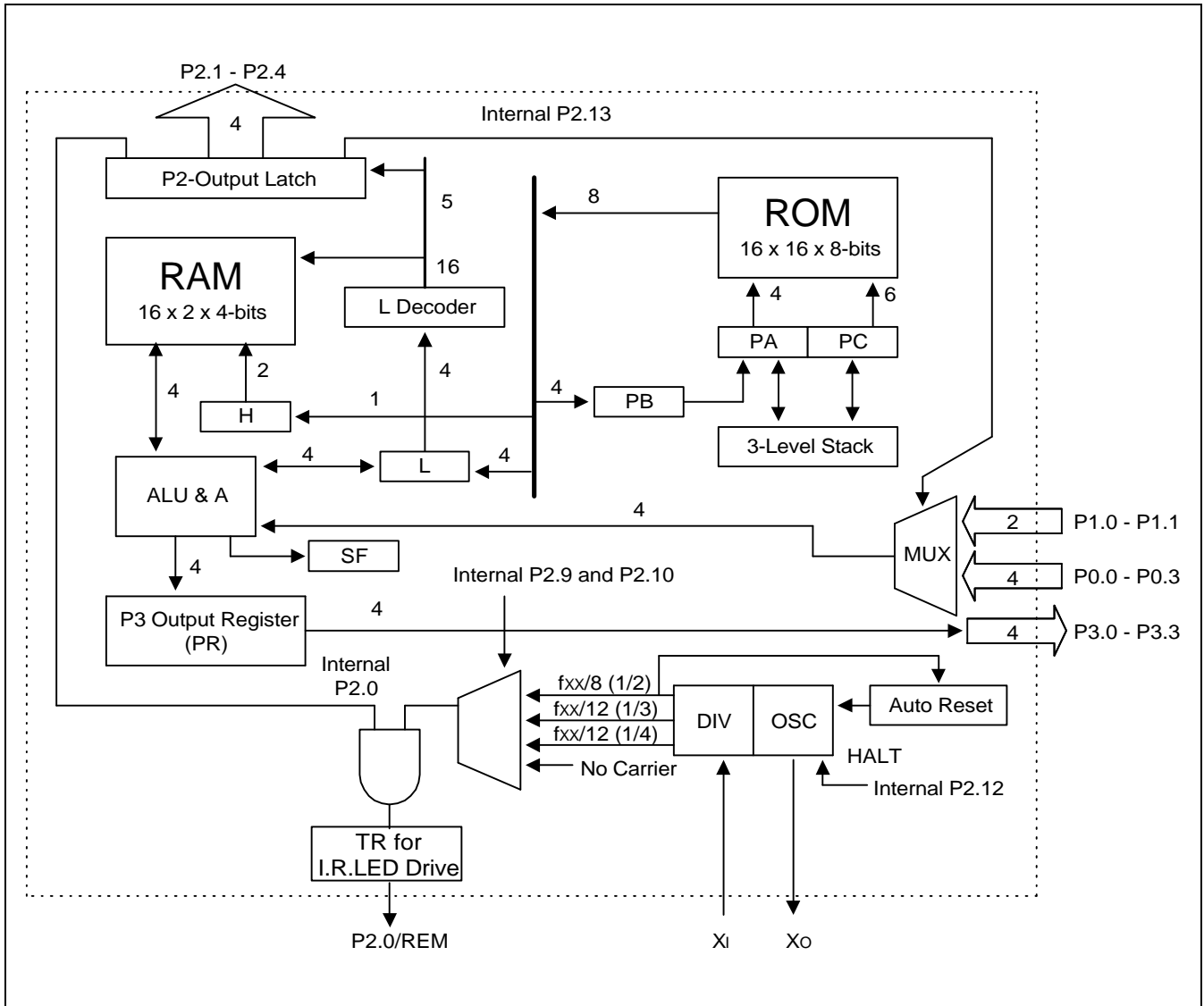

Figure 3-1. Block diagram

## PIN CONFIGURATION (20 DIP, 20 SOP)

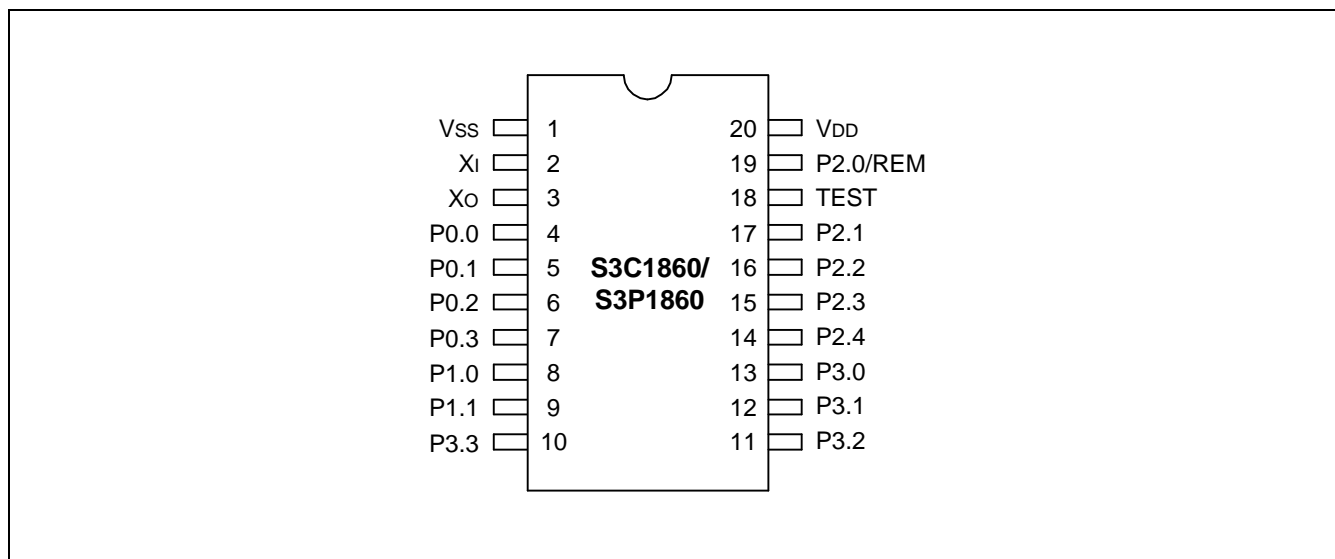

Figure 3-2. Pin Configuration (20 DIP, 20 SOP)

Table 3-1. Pin Description

Pin Name	Pin Number	Pin Type	Description	I/O Circuit Type
P0.0-P0.3	4, 5, 6, 7	Input	4-bit input port when P2.13 is low	A
P1.0-P1.1	8, 9	Input	2-bit input port when P2.13 is high	A
P2.0/REM	19	Output	1-bit individual output for remote carrier frequency <sup>(1)</sup>	B
P2.2-P2.4	16, 15, 14	Output	1-bit individual output port	C
P2.1	17			D
P3.0-P3.3	13, 12, 11, 10	Output	4-bit parallel output port	C
TEST	18	Input	Input pin for test (Normally connected to V <sub>SS</sub> )	—
X <sub>I</sub>	2	Input	Oscillation clock input	—
X <sub>O</sub>	3	Output	Oscillation clock output	—
V <sub>DD</sub>	20	—	Power supply	—
V <sub>SS</sub>	1	—	Ground	—

## NOTES:

- The carrier can be selected by software as fxx/12 (1/3 duty), fxx/12 (1/4 duty), fxx/8 (1/2 duty), or no-carrier frequency.
- Package type can be selected as 20 DIP, or 20 SOP in the ordering sheet.

I/O CIRCUIT SCHEMATICS

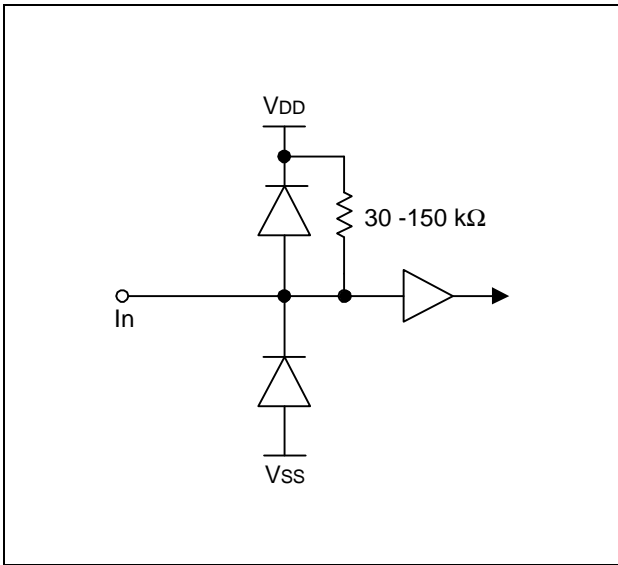

Figure 3-3. I/O Circuit Type A

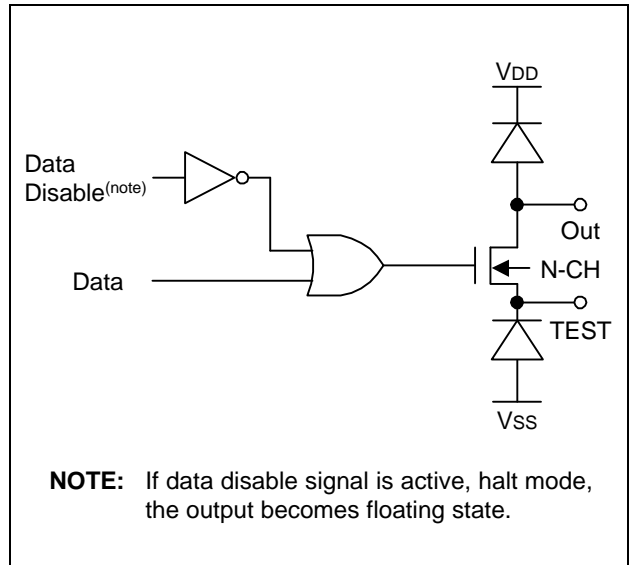

Figure 3-4. I/O Circuit Type B

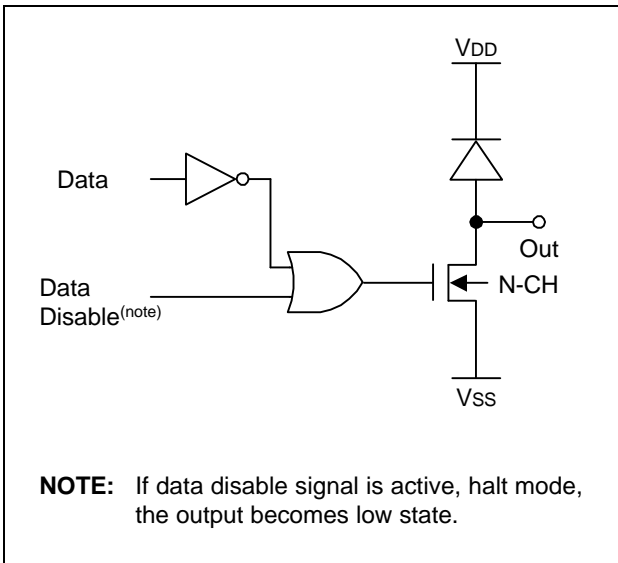

Figure 3-5. I/O Circuit Type C

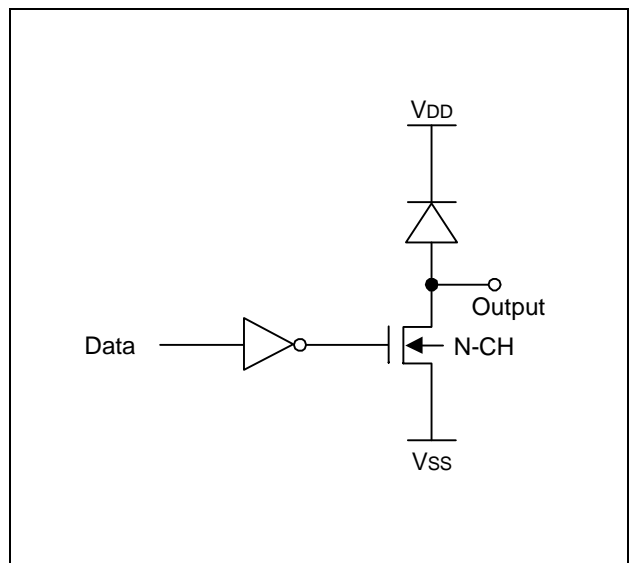

Figure 3-6. I/O Circuit Type D

Table 3-2. Absolute Maximum Ratings

Parameters	Symbols	Ratings	Units
Supply Voltage	$V_{DD}$	- 0.3 to 6	V
Input Voltage	$V_I$	- 0.3 to $V_{DD} + 0.3$	V
Output Voltage	$V_O$	- 0.3 to $V_{DD} + 0.3$	V
Soldering Temperature	$T_{SLD}$	260 (10 sec)	°C
Storage Temperature	$T_{STG}$	- 55 to 125	°C

Table 3-3. DC Characteristics

(V<sub>DD</sub> = 3 V, T<sub>A</sub> = 25 °C)

Parameters		Symbols	Test Conditions	Min	Typ	Max	Units
Supply Voltage <sup>(*NOTE)</sup>		$V_{DD}$	$250\text{kHz} \leq f_{OSC} \leq 3.9\text{MHz}$	1.8	3.0	3.6	V
			$3.9\text{MHz} < f_{OSC} \leq 6\text{MHz}$	2.2	3.0	3.6	
Operating Temperature		$T_A$	-	-20	-	85	°C
High-Level Input Voltage		$V_{IH1}$	All input pins except $X_{IN}$	$0.7 V_{DD}$	-	$V_{DD}$	V
		$V_{IH2}$	$X_{IN}$	$V_{DD}-0.3$	-	$V_{DD}$	V
Low-Level Input Voltage		$V_{IL1}$	All input pins except $X_{IN}$	0	-	$0.3 V_{DD}$	V
		$V_{IL2}$	$X_{IN}$	0	-	0.3	V
Low-Level Output Current P2.0		$I_{OL1}$	$V_O = 0.4 \text{ V}$	200	280	320	mA
			$V_O = 0.5 \text{ V}$	240	320	360	
Low-Level Output Current	P3 Output	$I_{OL2}$	$V_O = 0.4 \text{ V}$	0.5	1.0	2.0	mA
	P2.1-P2.3			1.5	3.0	4.5	
	P2.4			0.5	1.0	2.0	

Table 3-3. DC Characteristics

 $(V_{DD} = 3\text{ V}, T_A = 25\text{ }^\circ\text{C})$ 

Parameters	Symbols	Test Conditions	Min	Typ	Max	Units
High-Level Input Leakage Current	$I_{LIH1}$	$V_I = V_{DD}$ All input pins except X <sub>IN</sub>	–	–	3	uA
	$I_{LIH2}$	X <sub>IN</sub>	–	3	10	
Low-level Input Leakage Current	$I_{LIL1}$	X <sub>IN</sub>	– 0.6	– 3	– 10	
High-level Output Leakage Current	$I_{LOH}$	$V_O = V_{DD}$ All output pins Port 2,3	–	–	1	uA
Pull-up Resistance of Input Port	R	$V_{DD} = 3\text{ V}$ $V_I = 0\text{ V}$	30	70	150	K $\Omega$
Average Supply Current	$I_{DD}$	$V_{DD} = 3\text{ V}$ Crystal/Resonator Non-divide option $f_{OSC} = 1\text{ MHz}$	–	0.5	1.0	mA
		Divide-8 option $f_{OSC} = 6\text{ MHz}$				
HALT Current	$I_{DDH}$	$f_{OSC} = 0$	–	–	1.0	uA
Clock Frequency	f <sub>xx</sub>	Crystal/Ceramic	250	–	1000	kHz
Oscillator Frequency <sup>(note)</sup>	f <sub>OSC</sub>	Crystal/Ceramic Non-divide option	250	–	1000	
		Crystal/Ceramic Divide-8 option	2000	–	6000	

**NOTE :** In the S3P1860, Oscillator Frequency Divide Selection is not offered. The system clock (f<sub>xx</sub>) of S3P1860 is only Fosc/8, therefor, the available oscillator frequency range is 2000 kHz–6000 kHz.

## FUNCTIONAL DESCRIPTION

### Program Memory (ROM)

The program memory of S3C1860 consists of a 1024-byte ROM, organized in 16 pages. Each page is 64 bytes long. (See Figure 3-9).

ROM addressing is supported by a 10-bit register made up of two sub-registers: a 4-bit Page Address register (PA), and a 6-bit Program Counter (PC).

Pages 0 through 15 (FH) can each access 64 (3FH) bytes.

ROM addressing occurs as follows: The 10-bit register selects one of the ROM's 1024-bytes. A new address is then loaded into the PC register during each instruction cycle.

Unless a transfer-of-control instruction such as JP, CALL or RET is encountered, the PC is loaded with the next sequential 6-bit address in the page, PC + 1. In this case, the next address of 3FH would be 00H.

Only the PAGE instruction can change the Page Buffer (PB) to a specified value.

When a JP or CALL instruction is executed, and if the Status Flag is set to "1", the contents of the PB are loaded into the PA register. If the Status Flag is "0", however, the JP or CALL is executed like NOP instruction in an instruction cycle and the Status Flag is set to "1". After that, program execution proceeds.

### Page-In Addressing

All instructions, including, JP and CALL, can be executed by page. (See Figure3-7). When the Status Flag is "1", a JP or CALL causes a program to branch to its address (operand) in a page.

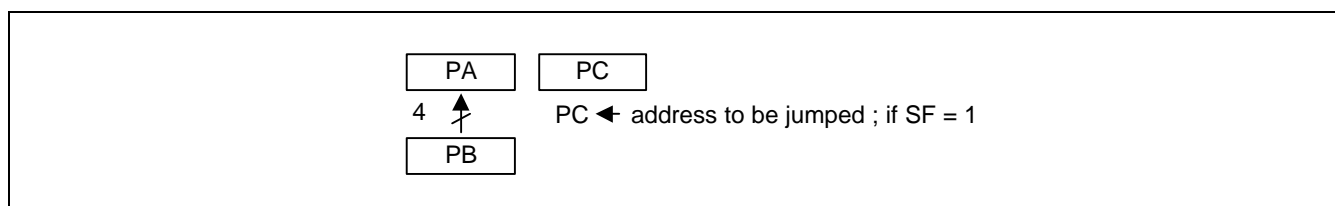

Figure 3-7. Page-In Addressing

### Page-To-Page Addressing

When a PAGE instruction occurs, and if the Status Flag is "1", a JP or CALL instruction will cause a program to branch to its address (operand) across the page (See Figure3-8).

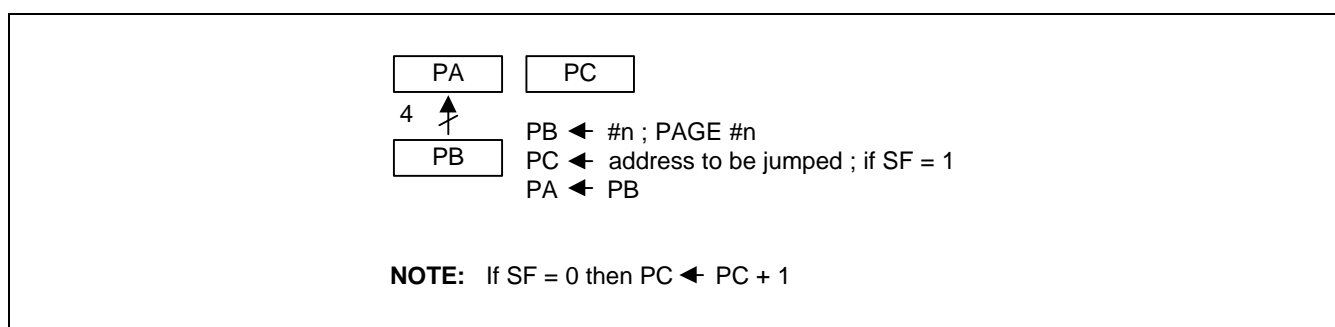
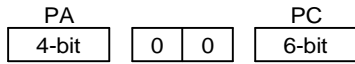

Figure 3-8. Page-to-Page Addressing





The 10-bit register points one of 1024 bytes at addresses 0000H to 0F3FH. After reset, it points to 0FXXH for execution in the first instruction cycle. it then becomes 0F00H in the next instruction cycle.

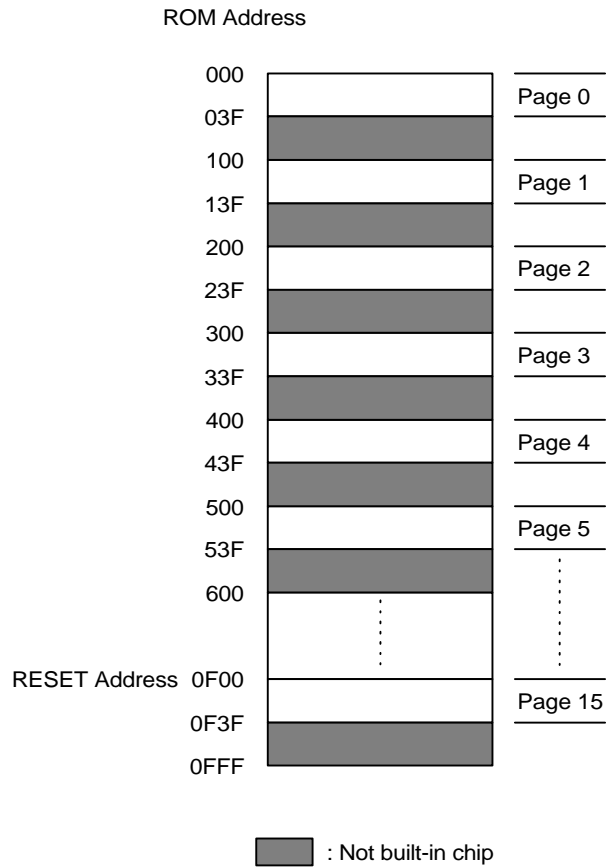

Figure 3-9. S3C1860 Program Memory Map

## DATA MEMORY (RAM)

The data memory of S3C1860 consists of a 32-nibble RAM which is organized into two files of 16 nibbles each (See Figure 3-10).

RAM addressing is implemented by a 7-bit register, HL.

Its upper 3-bit register (H) selects one of two files and its lower 4-bit register (L) selects one of 16 nibbles in the selected file.

Instructions which manipulate the H and L registers are as follow:

### Select a file :

MOV	H,#n	; H ← #n, where n must be 0,4
NOT	H	; Complement MSB of H register

### Select a nibble in a selected file :

MOV	L,A	; L ← A
MOV	L,@HL	; L ← M(H,L)
MOV	L,#n	; L ← #n, where $0 \leq n \leq 0FH$
INCS	L	; L ← L + 1
DECS	L	; L ← L - 1

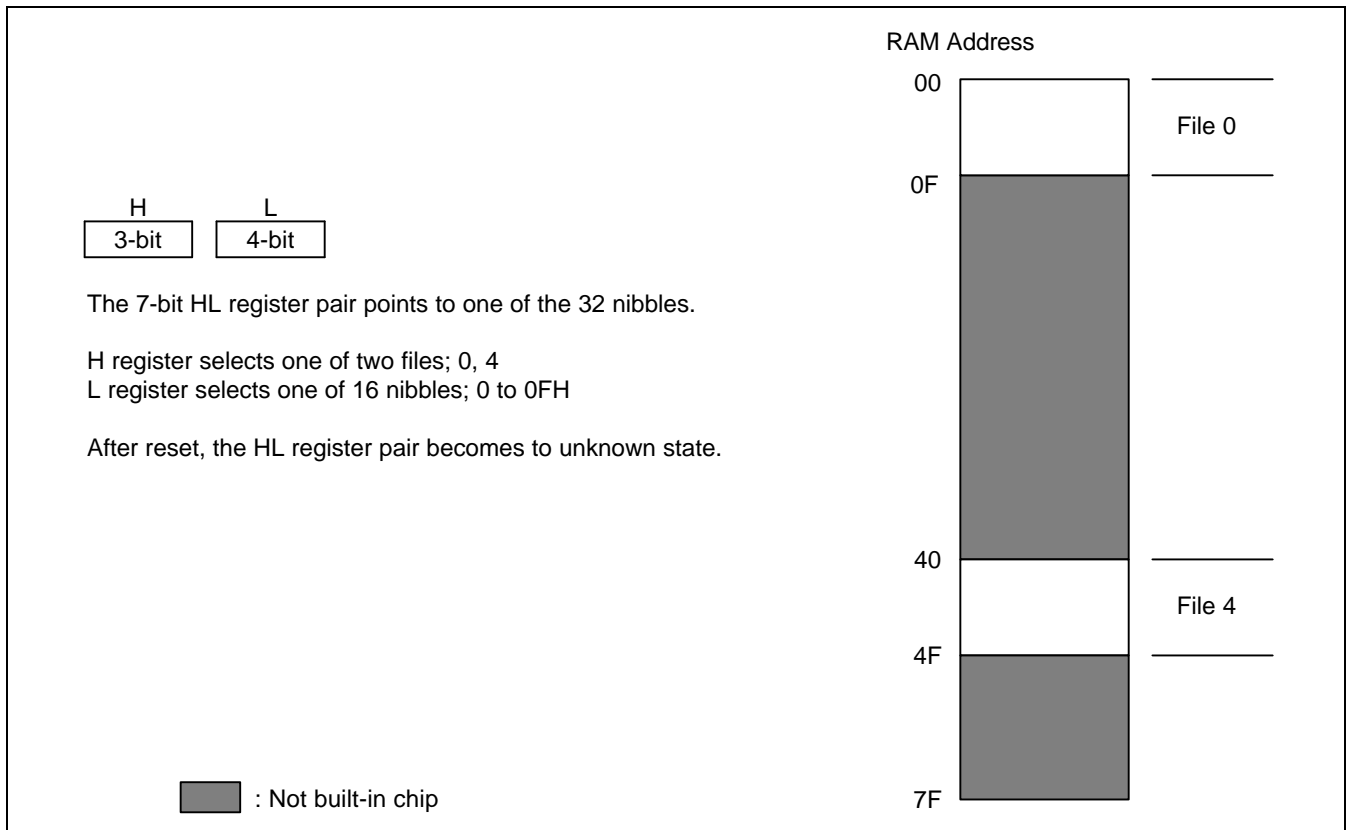

Figure 3-10. S3C1860 Data Memory Map

## REGISTER DESCRIPTIONS

### Stack Register (SR)

Three levels of subroutine nesting are supported by a three-level stack as shown in Figure 3-11.

Each subroutine call (CALL) pushes the next PA and PC address into the stack. The latest stack to be stored will be overwritten and lost. Each return instruction (RET) pops the stack back into the PA and PC registers.

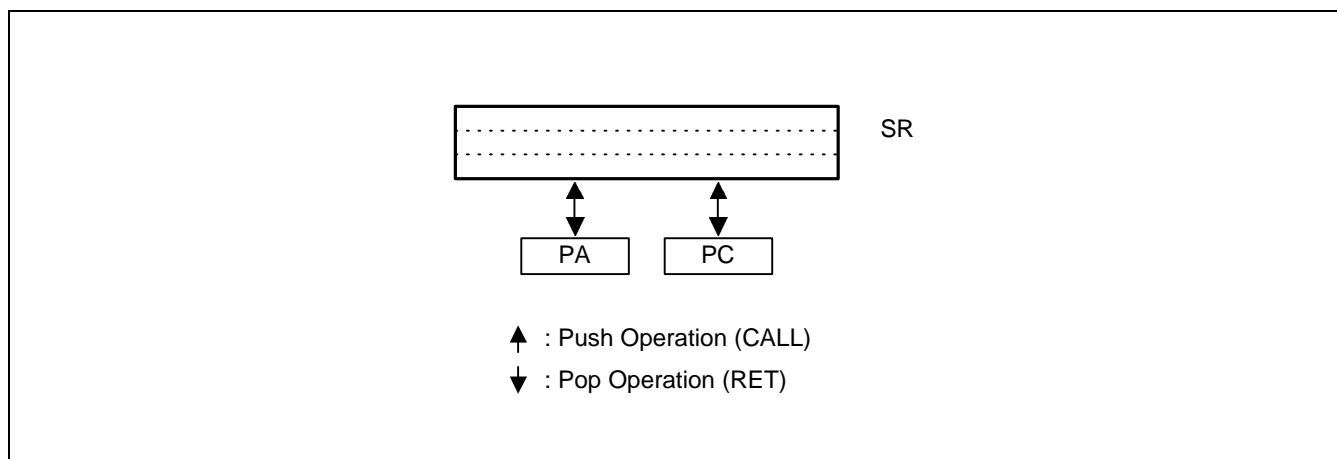

Figure 3-11. Stack Operations

### Page Address Register (PA), Page Buffer Register (PB)

The Page Address Register (PA) and Page Buffer Register (PB) are 4-bit registers. The PA always specifies the current page.

A page select instruction (PAGE #n) loads the value "n" into the PB. When JP or CALL instruction is executed, and if the Status Flag (SF) is set to 1, the contents of PB are loaded into PA. If SF is "0", however, the JP or CALL is executed like NOP instruction and SF is set to "1". The contents of PB don't be loaded. Figure 3-12 illustrates this concept.

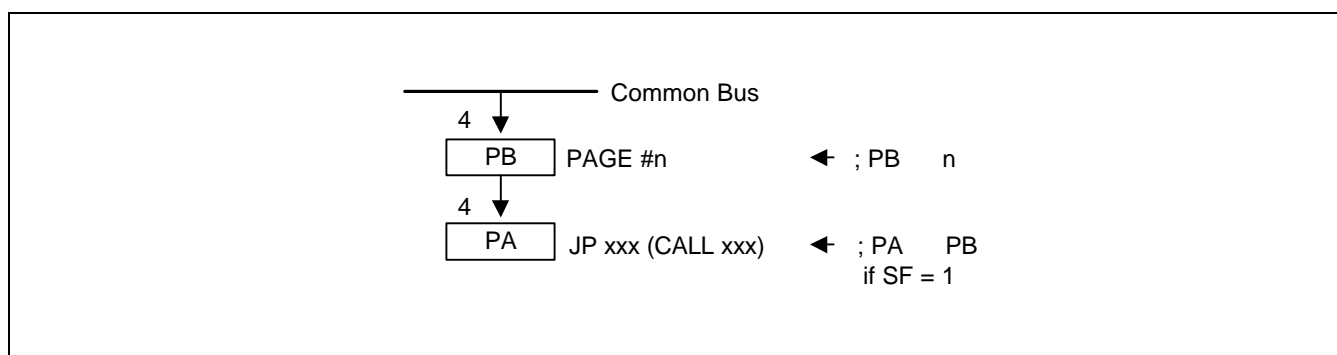

Figure 3-12. PA, PB Operations

### Arithmetic Logic Unit (ALU), Accumulator (A)

The SMCS-51 CPU contains an ALU and its own 4-bit register (accumulator) which is the source and destination register for most I/O, arithmetic, logic, and data memory access operations. Arithmetic functions and logical operations will set the status flag (SF) to "0" or "1".

### Status Latch (SL)

The Status latch (SL) flag is a 1-bit flip-flop register. Only the "CPNE L,A" instruction can change the value of SL.

If the result of a "CPNE L,A" instruction is true, the SL is set to "1"; If not true, to "0".

### Status Flag : SF

The Status Flag (SF) is a 1-bit flip-flop register which enables programs to conditionally skip an instruction. All instructions, including JP and CALL, are executed when SF is "1".

But if SF is "0", the program executes NOP instruction instead of JP or CALL and resets SF to "1". Then, program execution proceeds. The following instructions set the SF to "0".

#### • Arithmetic Instructions

ADDS	A,#n	; if no carry
ADDS	A,@HL	; if no carry
INCS	A,@HL	; if no carry
INCS	A	; if no carry
INCS	L	; if no carry
SUBS	A,@HL	; if borrow
DECS	A,@HL	; if borrow
DECS	A	; if borrow
DECS	L	; if borrow

#### • Compare Instructions

CPNE	@HL,A	; if M(H,L) = (A)
CPNZ	@HL	; if M(H,L) = 0
CPNE	L,#n	; if (L) = #n
CPNE	L,A	; if (L) = (A)
CPNE	A,@HL	; if (A) > M (H,L)
CPNZ	P0	; if (P0) = 0
CPBT	@HL.b	; if M(H,L,b) ≠ 1

#### • Data Transfer Instructions

MOV	@HL+,A	; if no carry
MOV	@HL-,A	; if borrow

#### • Logical Instructions

NOTI	A	; if (A) ≠ 0 after operation
------	---	------------------------------

## INPUT PORTS : P0, P1

The P0 and P1 input ports have internal pull-up 30-150 K $\Omega$  resistors, (See I/O circuit type A), each multiplexed to a common bus (See Figure 3-13). If the P2.13 pin is programmed to low, then port 0 is selected as the input port. Otherwise, if the P2.13 pin high, port 1 is selected.

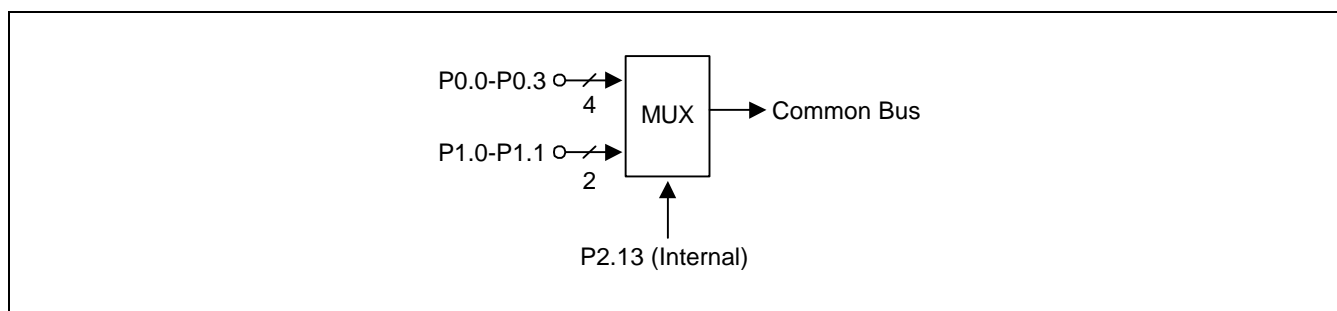

Figure 3-13. S3C1860 Input Port

## OUTPUT PORTS : P2, P3

The P2 and P3 output ports can be configured as N-CH. Transistor (P2.0/REM only) and open drain (P2.1-P2.4, P3.0-P3.3) as follows:

- N-channel Transistor for I.R.LED drive : A CMOS P2.0 N-CH. Transistor with P2.0/REM and TEST (see I/O Circuit Type B). P2.0/REM becomes floating state in halt mode.
- N-channel open drain : An N-channel transistor to ground, compatible with CMOS and TTL. (see I/O Circuit Type C and D). P2.2-P2.4 and P3.0-P3.3 pins become low state in halt mode.

The L register specifies P2 output pins (P2.0/REM-P2.4, P2.9-P2.10, P2.12, and P2.13) individually as follows:

- SETB P2.(L) : Set port 2 bits to correspond to L-register contents.
- CLRB P2.(L) : Clear port 2 bits to correspond to L-register contents.

P3 output pins P3.0-P3.3 are parallel output pins.

For the S3C1860, only the 4-bit accumulator outputs its value to the P3 port by the output instruction "OUT P3, @SL+ A" (the value of the Status Latch (SL) does not matter).

**TRANSMISSION CARRIER FREQUENCY**

One of four carrier frequencies can be selected and transmitted through the P2.0/REM pin by programming the internal P2.9, P2.10 and P2.0 pins (See Table 3-5). Figure 3-14 shows a simplified diagram of the various transmission circuits.

**Table 3-5. Carrier Frequency Selection Table**

P2.10	P2.9	Carrier Frequency of P2.0/REM Pin
0	0	$f_{xx}/12$ , 1/3 duty
0	1	$f_{xx}/8$ , 1/2 duty
1	0	$f_{xx}/12$ , 1/4 duty
1	1	No carrier

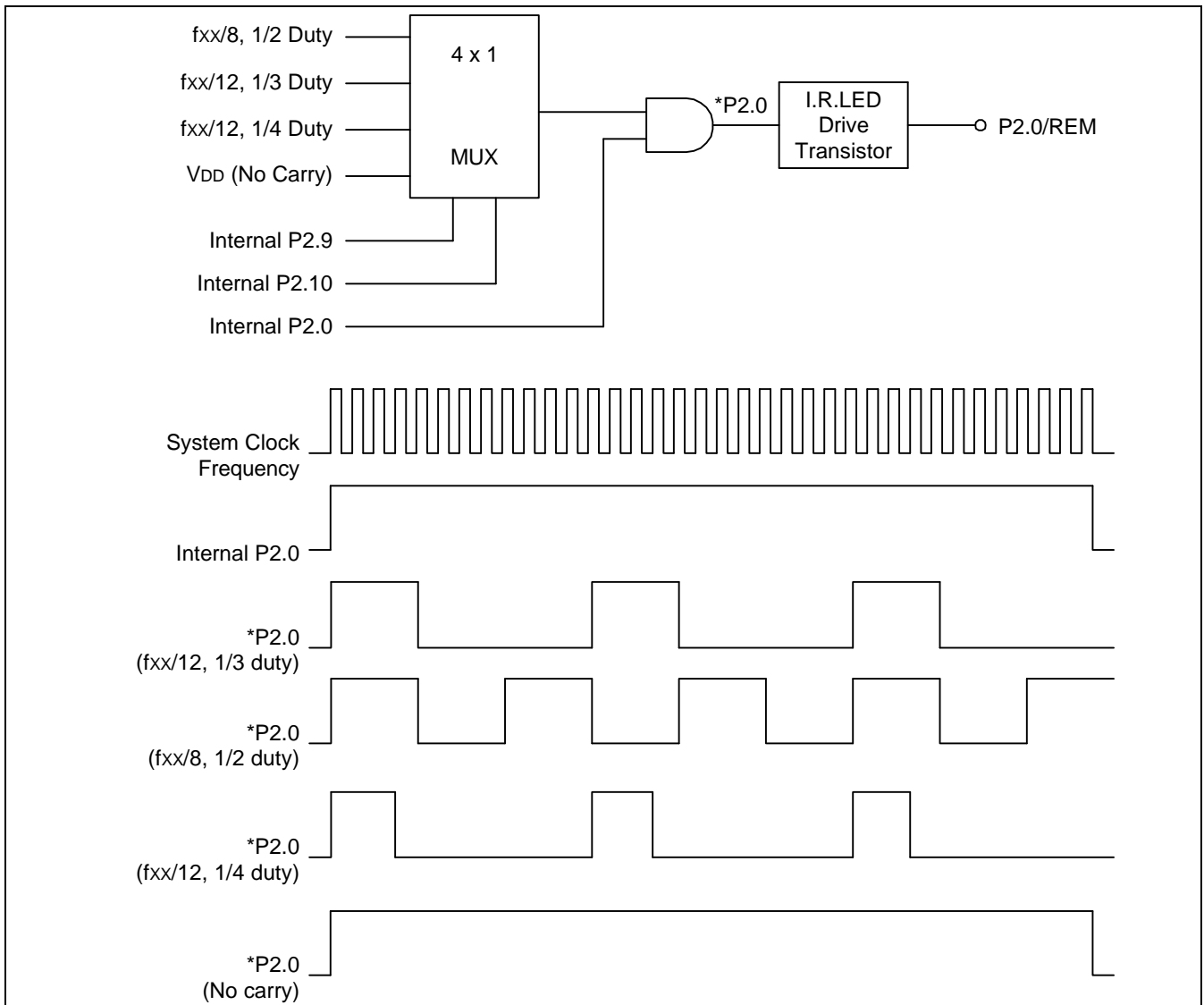

**Figure 3-14. Diagram of Transmission Circuits**

**HALT MODE**

The HALT mode is used to reduce power consumption by stopping the clock and holding the states of all internal operations fixed. This mode is very useful in battery-powered instruments. It also holds the controller in wait status for external stimulus to start some event. The S3C1860 can be halted by programming the P2.12 pin high, and by forcing P0 input pins (P0.0-P0.3) to high and P1 input pins (P1.0-P1.1) to high, concurrently (See Figure 3-15). When in HALT mode, the internal circuitry does not receive any clock signal, and all P2, P3 output pins become low states. However, P2.0 pin becomes floating state, P2.1 pin retains their programmed values until the device is re-started as follows:

- Forcing any P0 and P1 input pins to low : system reset occurs and it continues to operate from the reset address.

An oscillation stabilization time of 13 msec in f<sub>xx</sub> = 455 kHz crystal oscillation is needed for stability (See Figure 1-16).

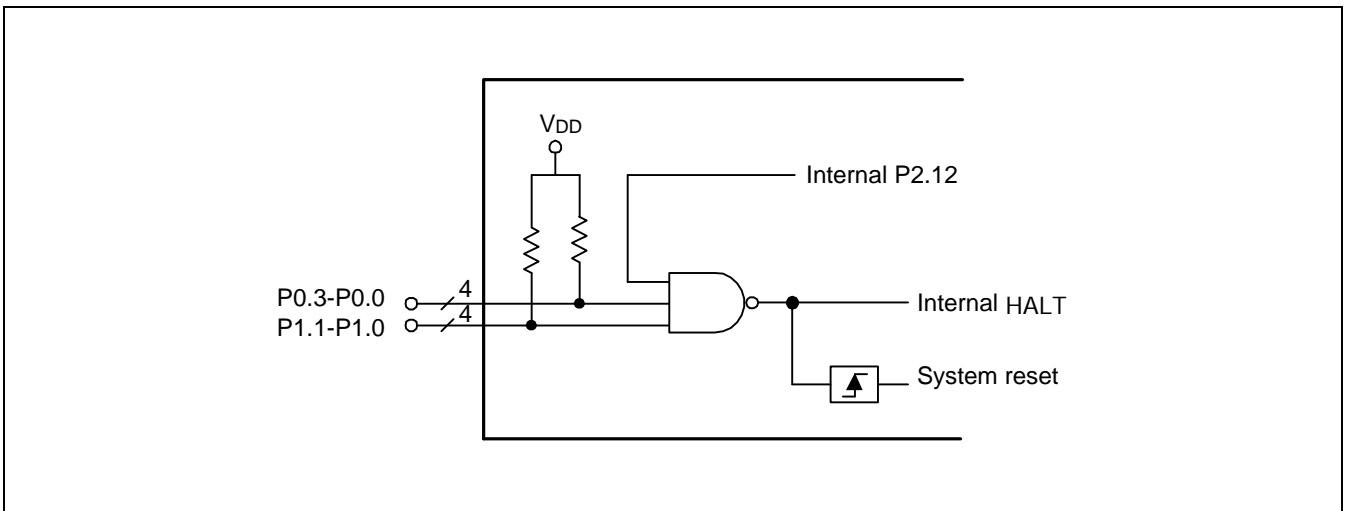

**Figure 3-15. Block Diagram of HALT Logic**

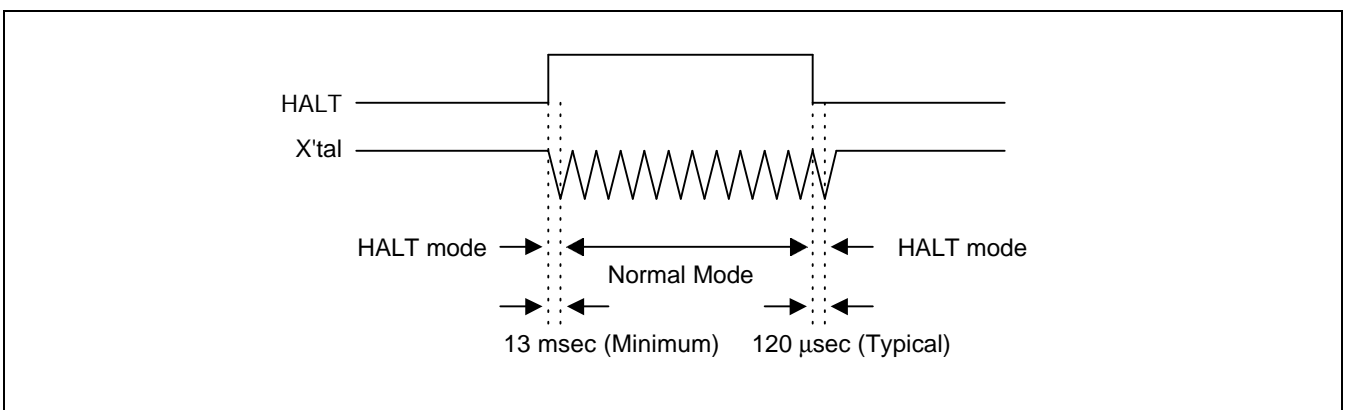

**Figure 3-16. Release Timing for HALT or RESET to Normal Mode in Crystal Oscillation**



## RESET

All reset operations are internal in the S3C1860. It has three kinds of reset sources as follows (To obtain more information about reset operation, see Chapter 6. Remote Control Tx) :

- Oscillation Start and Reset (OSR)
- Reset by Halt mode release
- Auto-Reset

### Oscillation Start and Reset (OSR)

A system reset pulse occurs when the chip is in non-operating voltage with oscillation.

### Auto-Reset

Auto-Reset circuit resets the chip every 131,072 oscillator clock cycles (288ms at a f<sub>clk</sub> = 455 kHz clock frequency). The auto-reset counter is cleared by the rising edge of a internal P2.0 pin, by HALT, or by OSR. Therefore, no clocks are sent to the counter and the time-out is suspended in HALT mode.

When a reset occurs during program execution, a transient condition occurs. The PA register is immediately initialized to 0FH. The PC, however, is not reset to 0H until one instruction cycle later. For example, if PC is 1AH when a reset pulse is generated, the instruction at 0F1AH is executed, followed by the instruction at 0F00H.

After a reset, approximately 13 msec is needed before program execution proceeds (assuming f<sub>clk</sub> = 455 kHz ceramic oscillation).

Upon initialization, registers are set as follows:

- PC register to 0 in next instruction cycle
- PA and PB registers to 0FH (15th page)
- SF and SL registers to 1
- H,L registers to unknown state
- All internal/external output pins (P3.0-P3.3, P2.1-P2.4, P2.9, P2.10, P2.12 and P2.13 except P2.0/REM) to low.

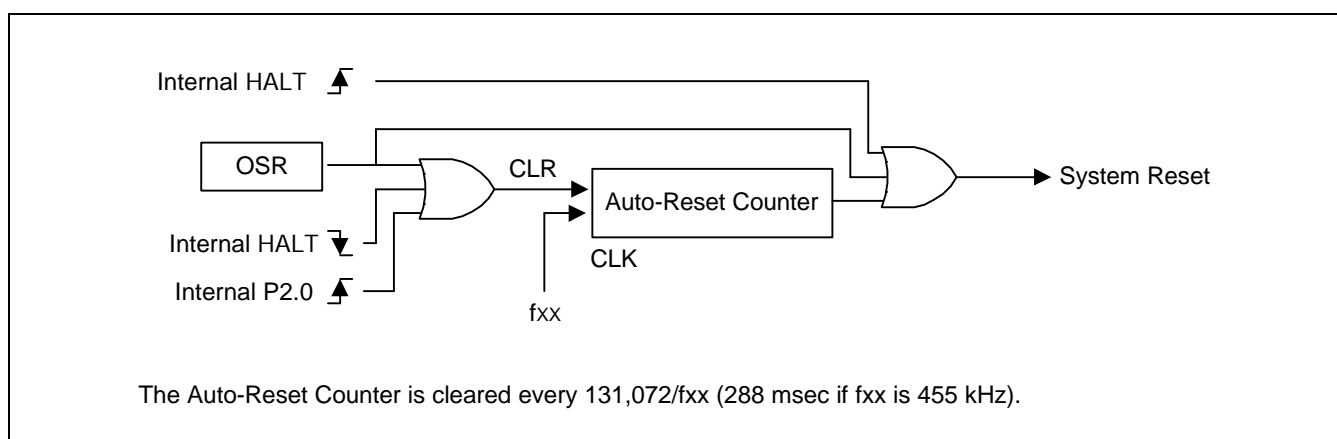

Figure 3-17. Auto Reset Block Diagram

### OSC DIVIDE OPTION CIRCUIT

The OSC Divide Option Circuit provides a maximum 1 MHz  $f_{xx}$  system clock.  $f_{OSC}$  which is generated in oscillation circuit is divided eight or non-divide in this circuit to produce  $f_{xx}$ . This dividing ratio will be chosen by mask option. (See Figure 3-20)

$f_{OSC}$  : Oscillator clock

$f_{xx}$  : System clock ( $f_{OSC}$  or  $f_{OSC}/8$ )

$f_{CPU}$  : CPU clock ( $f_{CPU} = f_{xx}/6$ )

1 instruction cycle clock

### NOTE

In the S3P1860, the OSC Divide Option is not offered and  $f_{OSC}/8$  is only used for system clock ( $f_{xx}$ ).

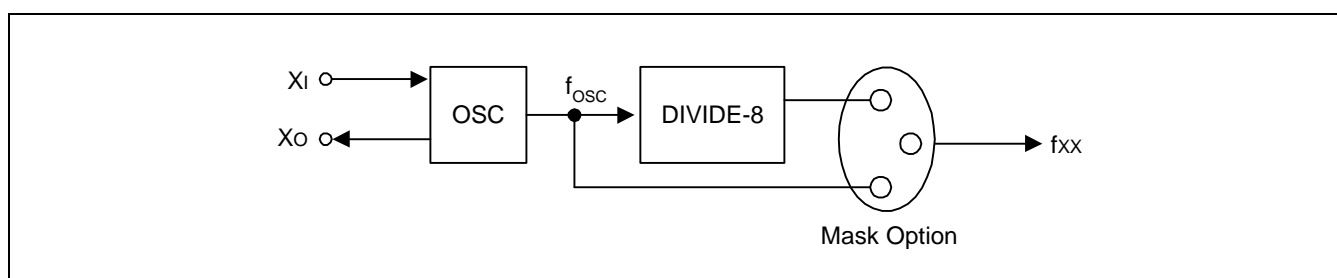

Figure 3-18. S3C1860 OSC Divide Option Circuit

PACKAGE DIMENSIONS

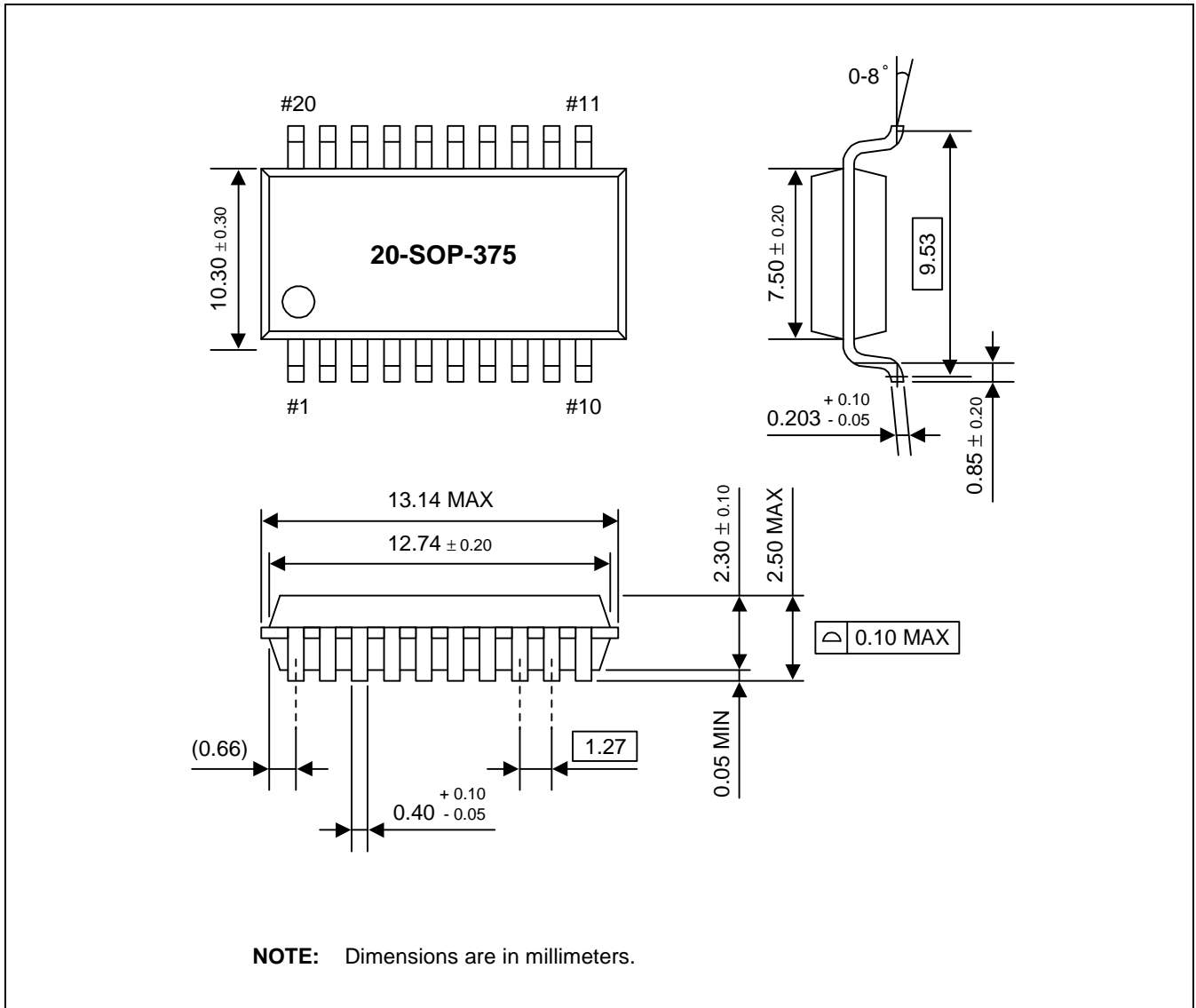
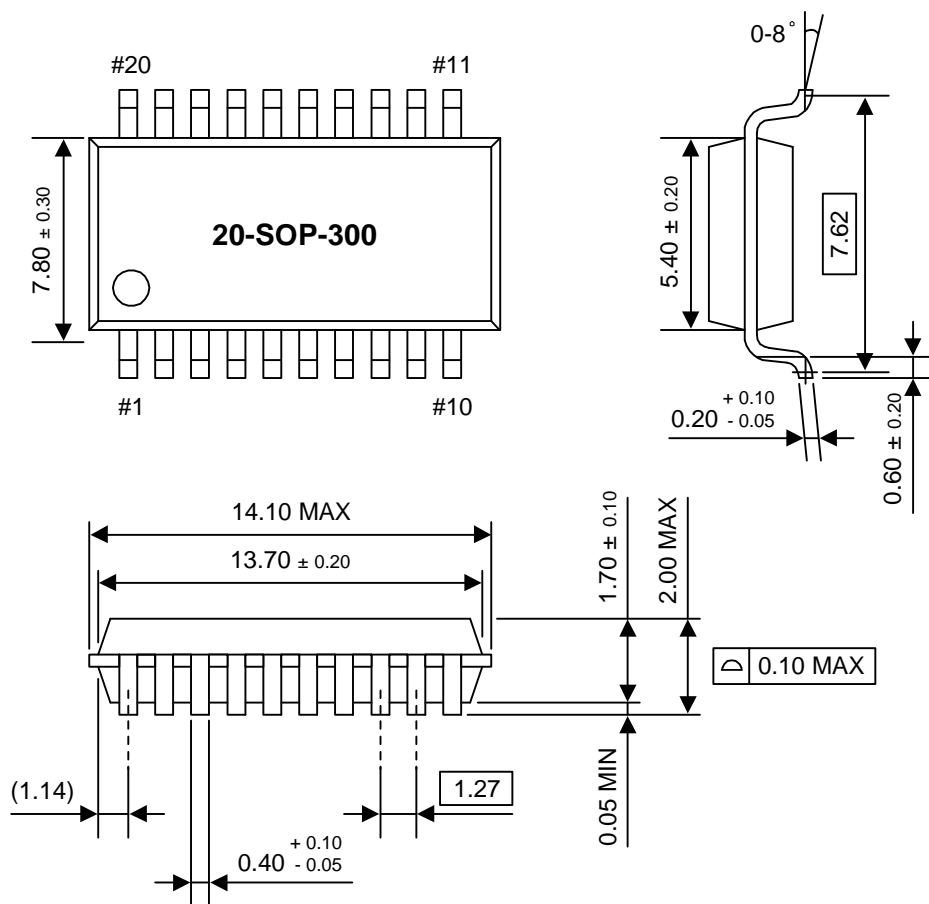

Figure 3-19. 20-SOP-375



**NOTE:** Dimensions are in millimeters.

Figure 3-20. 20-SOP-300

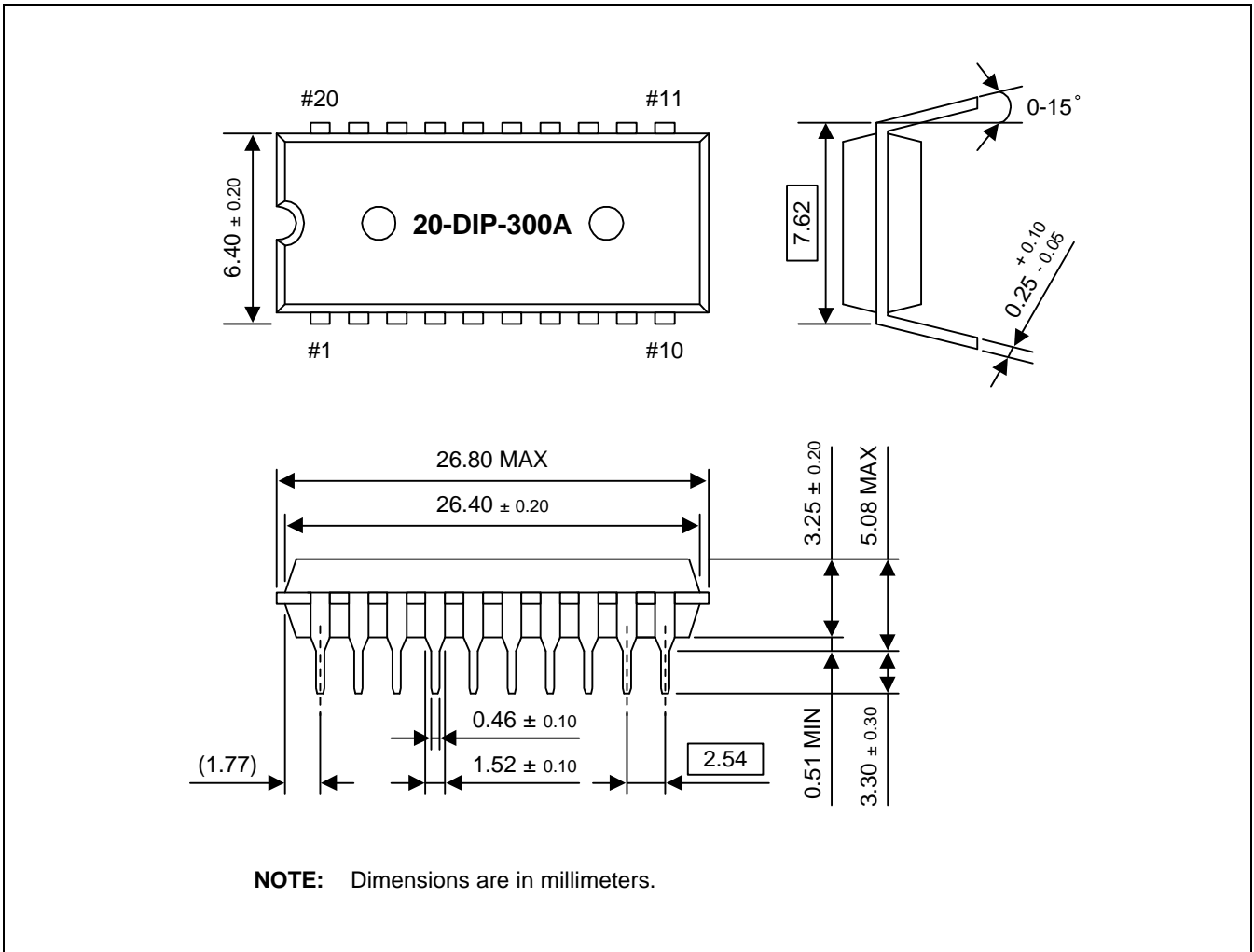
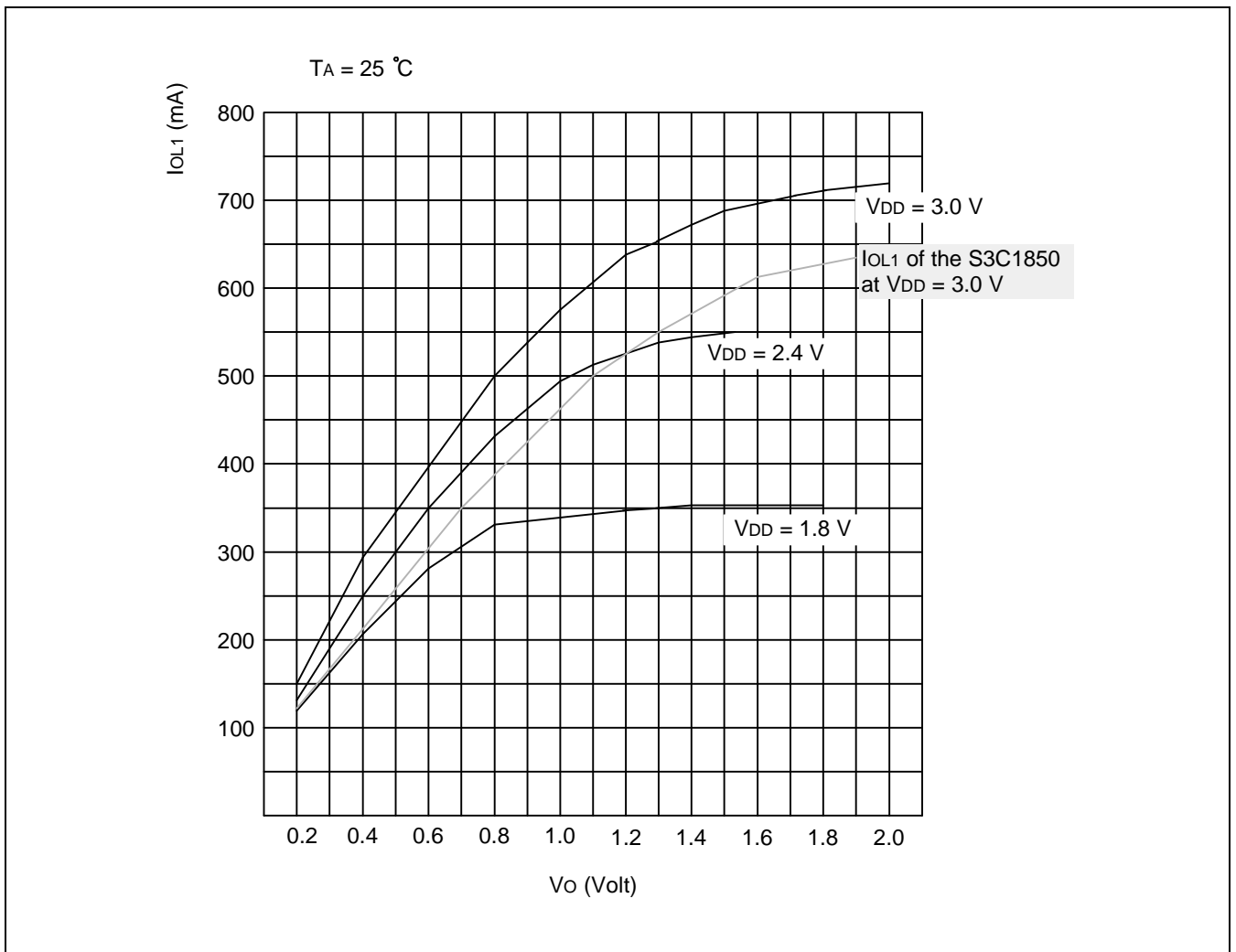

Figure 3-21. 20-DIP-300A

## ELECTRICAL CURVES

Figure 3-22.  $I_{OL1}$  vs  $V_O$  (P2.0)

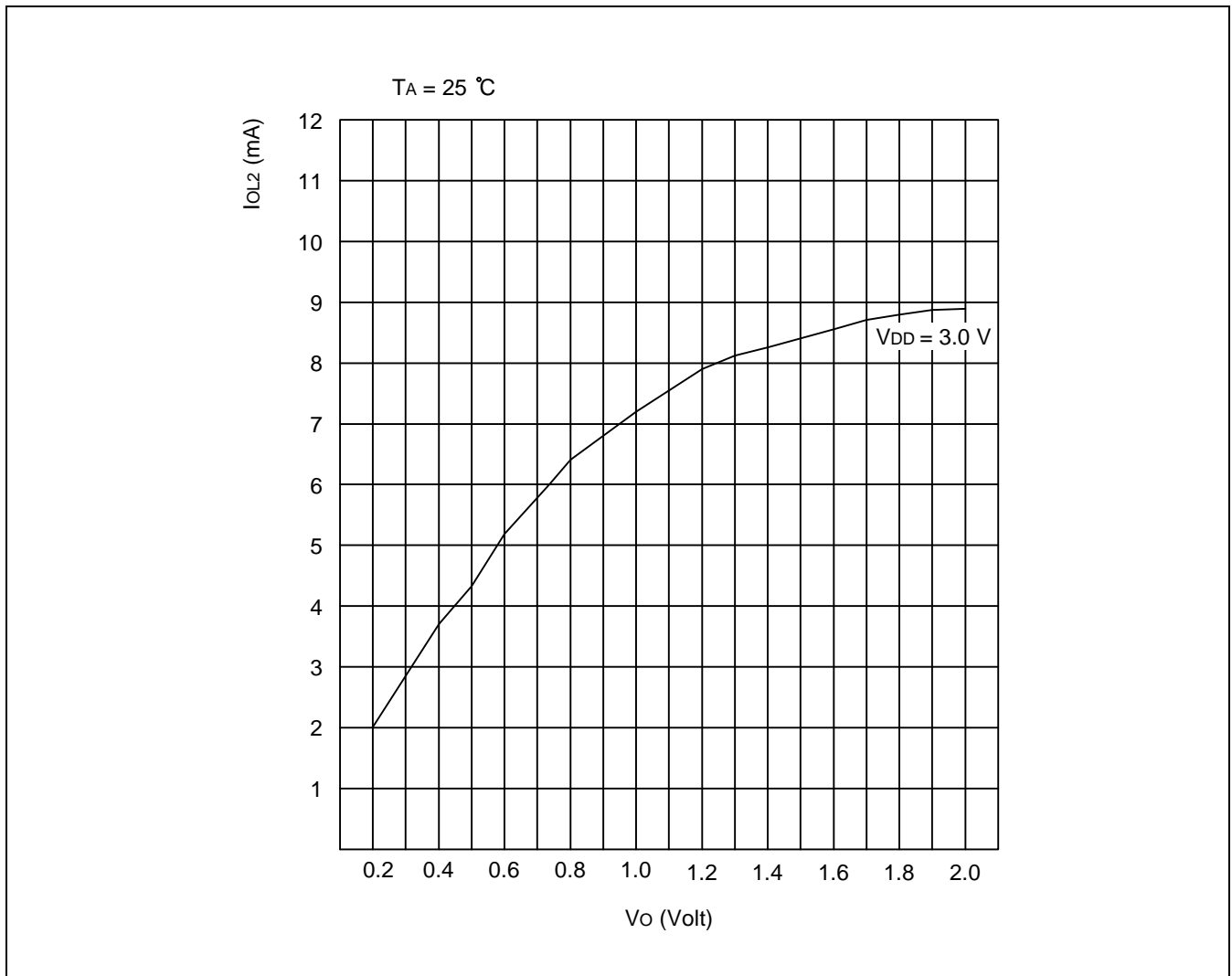

Figure 3-23.  $I_{OL2}$  vs  $V_O$  (P2.1-P2.3)

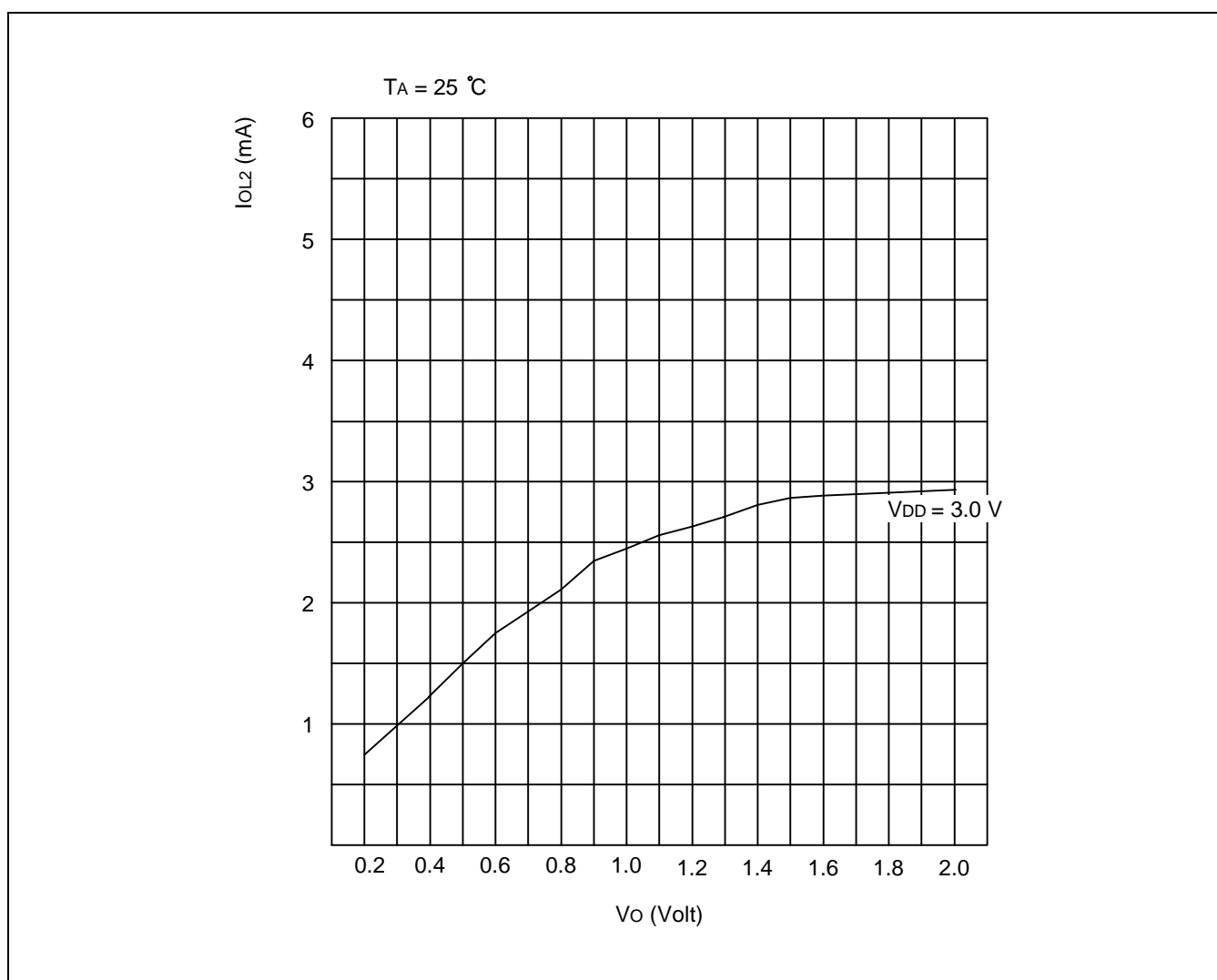

Figure 3-24.  $I_{OL2}$  vs  $V_O$  (P3.0-P3.3)



## **4. S3P1860**

## DESCRIPTION

The S3P1860, a 4-bit single-chip CMOS microcontroller is the OTP (One Time Programmable) version of the S3C1860 microcontroller and it is on the development. It has an on-chip OTP ROM instead of masked ROM. The EPROM is accessed by serial data format.

The S3P1860 is fully compatible with the S3C1860, both in function and in pin configuration except Oscillation Frequency Divide Option. **In the S3P1860, the oscillation frequency Divide Option is not offered and Fosc/8 is only used for the system clock (fxx).**

## PIN CONFIGURATION (20 DIP, 20 SOP)

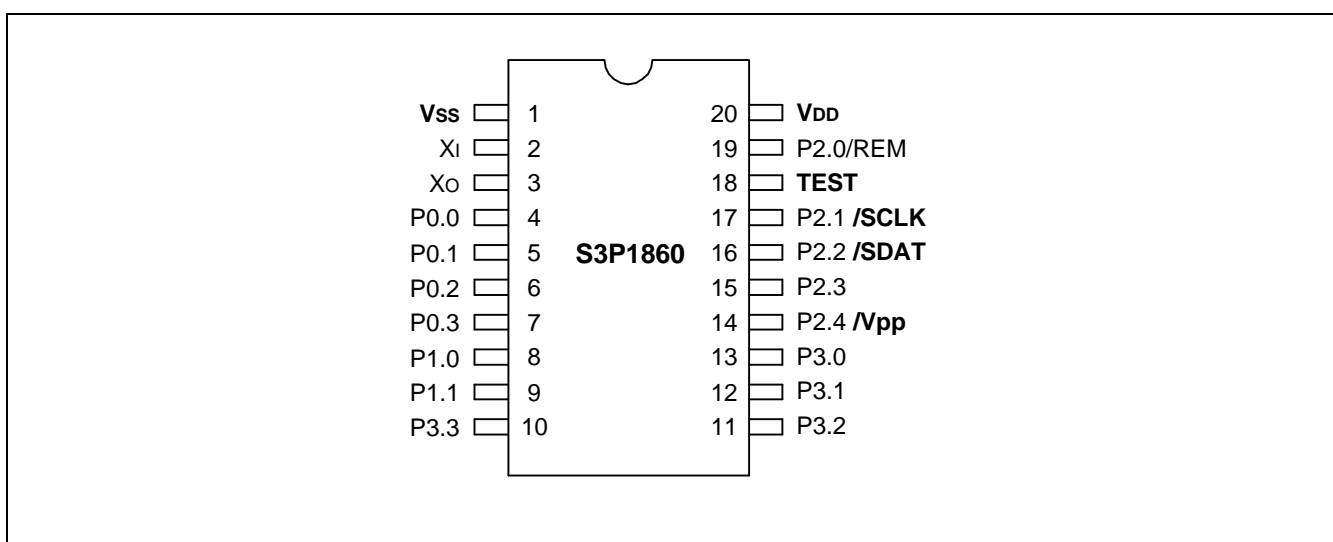

Figure 4-1. S3P1860 Pin Configuration (20 DIP, 20 SOP)

Table 4-1. Descriptions of Pins Used to Read/Write the EPROM

Main Chip Pin Name	During Programming			
	Pin Name	Pin No.	I/O	Function
P2.2	SDAT	16	O	Serial data pin. Output port when reading and input port when writing. Can be assigned as a input/push-pull output port.
P2.1	SCLK	17	O	Serial clock pin. Input only pin
P2.4	V <sub>PP</sub>	14	O	Power supply pin for EPROM cell writing (indicates that OTP enters into the writing mode). When 12.5 V is applied, OTP is in writing mode and when 5 V is applied, OTP is in reading mode. (Option)
V <sub>DD</sub> /V <sub>SS</sub>	V <sub>DD</sub> /V <sub>SS</sub>	20/1	–	Logic power supply pin. V <sub>DD</sub> should be tied to + 5 V during programming
TEST	OTP	18	–	TEST should be tied to + 5 V during programming
P0.0	Programming	4	I	P0.0 should be tied to + 5 V during programming
P0.1	Mode Control	5	I	P0.1 should be tied to + 5 V during programming
P0.2	Pins	6	I	P0.2 should be tied to + 5 V during programming
P0.3		7	I	P0.3 should be tied to 0 V during programming
P1.0		8	I	P1.0 should be tied to + 5 V during programming
P1.1		9	I	P1.1 should be tied to + 5 V during programming

Table 4-2 Comparison of S3C1860 and S3P1860 Features

Characteristic	S3C1860	S3P1860
Program Memory (ROM)	1024 bytes	1024 bytes
Data Memory (RAM)	32 nibbles	32 nibbles
Supply Voltage	1.8 V to 3.6 V (250 kHz ≤ f <sub>OSC</sub> ≤ 3.9 MHz) 2.2 V to 3.6 V (3.9 MHz < f <sub>OSC</sub> ≤ 6 MHz)	1.8 V to 3.6 V (2 MHz ≤ f <sub>OSC</sub> ≤ 3.9 MHz) 2.2 V to 3.6 V (3.9 MHz < f <sub>OSC</sub> ≤ 6 MHz)
Oscillator Frequency	Non-divide Option: 250 kHz – 1 MHz Divide-8 Option: 2 MHz – 6 MHz	Divide-8 Option : 2MHz – 6MHz
Oscillator Frequency Divide Select	Mask Option : f <sub>xx</sub> = f <sub>OSC</sub> or f <sub>OSC</sub> /8	Only f <sub>OSC</sub> /8
Pin Configuration	20 DIP, 20 SOP	20 DIP, 20 SOP
EPROM Programmability	Programmed at the factory	User Program 1 time

## **5. INSTRUCTION SET**

## INSTRUCTION SET DESCRIPTION

Abbreviations and symbols table specifies internal architecture, instruction operand and operational symbols.

As mentioned before, JP and CALL instructions are executed normally only when SF is high. If SF is low, the program executes NOP instruction instead of them and sets SF to high. And then, the program executes a next instruction. In addition, JPL and CALL are long jump and long call instructions which consists of PAGE and JP/CALL instructions.

**Table 5-1. Abbreviations and Symbols**

Symbol	Description	Symbol	Description
L	L register (4 bits)	SF	Status Flag
A	Accumulator (4 bits)	P3	P4-output
(L)	The contents of the L register	P0	P0 input (4 bits)
(A)	The contents of the accumulator	D	Any binary number
SL	Status latch (1 bit)	DST	Destination operand
PB	Page buffer register (4 bits)	C	Carry Flag
PA	Page address register (4bits)	SRC	Source operand
P2	P2-output	REG	Register
PC	Program counter	←	Transfer
SR	Stack register	+	Addition or increment by 1
H	H register	≤	Equal or less than
M	RAM addressed by H and L registers	( )	The complement of the contents
(H)	The contents of the H register	@	Indirect register address prefix
M (H,L)	The contents of the RAM addressed by H,L	#n	Constant n (immediate 3or 4-bit data)
b	Bit address of the RAM [(H,L)] addressed by H,L	↔	Is exchanged with
≠	Not equal to	-	Subtract or decrement by 1

Table 5-2. Instruction Set Summary

Mnemonic	Operand	Description
<b>MOV Instructions</b>		
MOV	L,A	Move A to register L
MOV	A,L	Move L register to A
MOV	@HL,A	Move A to indirect data memory
MOV	A,@HL	Move indirect data memory to A
MOV	L,@HL	Move indirect data memory to register L
MOV	@HL+,A	Move A to indirect data memory and increment register L
MOV	@HL-,A	Move A to indirect data memory and decrement register L
MOV	L,#n	Move immediate data to register L
MOV	H,#n	Move immediate data to register H
MOV	@HL+,#n	Move immediate data to indirect data memory and increment register L
MOVZ	@HL,A	Move A to indirect data memory and clear A
XCH	@HL,A	Exchange A with indirect data memory
PAGE	#n	Set PB register to n
<b>Program Control Instructions</b>		
CPNE	@HL,A	Compare A to indirect data memory and set SF if not equal
CPNZ	@HL	Set SF if indirect data memory
CPNE	L,A	Compare A to register L, set SF and SL if not equal
CPNE	L,#n	Compare immediate data to register L and set SF if not equal
CPL	A,@HL	Set SF if A is less than or equal to indirect data memory
CPNZ	P0	Set SF if A is less than or equal to indirect data memory
CPBT	@HL,b	Test indirect data memory bit and set SF if indirect bit is one
JP	dst	Jump if SF flag is set
CALL	dst	Call subroutine if SF is set
RET		Return from subroutine
<b>I/O Instructions</b>		
SETB	P2.(L)	Set bit
CLRB	P2.(L)	Clear bit
IN	A,P0	Input P0 to A
OUT	P3,@SL+A	Output A to P4-PLA output port
<b>Logical Instructions</b>		
NOTI	A	Complement A and increment A
NOT	H	Complement MSB of H register
CLR	A	Clear
<b>Arithmetic Instructions</b>		
ADDS	A,@HL	Add indirect data memory to A
ADDS	A,#n	Add immediate data to A
SUBS	A,@HL	Subtract A from indirect data memory
INCS	A,@HL	Increment indirect data memory and load the result in A
INCS	L	Increment register L
INCS	A	Increment A
DECS	A	Decrement A
DECS	A,@HL	Decrement indirect data memory and load the result in A
DECS	L	Decrement register L
<b>Bit Manipulation Instruction</b>		
SETB	@HL.b	Set indirect data memory bit
CLRB	@HL.b	Clear indirect data memory bit

Upper Nibble (Hex)		Lower Nibble (Hex)															
		0	1	2	3	4	5	6	7	8	9	A	B	C	D	E	F
0	CPNE @HL,A	CPLA A,@HL	CPNE L,A	XCH @HL,A	DECS L	INCS L	ADDS A,@HL	DECS A,@HL	IN A,P0	NOT H	OUT P3,@SL+A			CLRB P2.(L)	SETB P2.(L)	CPNZ P0	RET
1	PAGE #n	.....▶															
2	MOV L,A	MOV A,@HL	MOV L,@HL	MOV A,L	MOV @HL-,A	MOV @HL+,A	MOVZ @HL,A	MOV @HL,A	MOV H,#n	.....▶							
3	SETB @HL.b	.....▶			CLRB @HL.b	.....▶			CPBT @HL.b	.....▶				SUBS A,@HL	NOTI A	INCS A,@HL	CPNZ @HL
4	MOV L,#n	.....▶															
5									CPNE L,#n	.....▶							
6	MOV @HL+#N	.....▶															
7	INCS A	ADDS A,#n	.....▶					DECS A	ADDS A,#n	.....▶							CLR A
8	JP	.....▶															
9	JP	.....▶															
A	JP	.....▶															
B	JP	.....▶															
C	CALL	.....▶															
D	CALL	.....▶															
E	CALL	.....▶															
F	CALL	.....▶															

Figure5-1. KS51 Opcode Map

**MOV L,A**

Binary Code: 

0 0 1 0	0 0 0 0
---------	---------

Description: The contents of the accumulator are moved to register L.  
The contents of the source operand are not affected.

Operation:  $(L) \leftarrow (A)$

Flags: SF : Set to one  
SL : Unaffected

Example: CLR        A                   ; Clear the contents of A  
          MOV       L,A               ; Move 0H to REG L

**MOV A,L**

Binary Code: 

0 0 1 0	0 0 1 1
---------	---------

Description: The contents of register L are moved to the accumulator.  
The contents of the source operand are not affected.

Operation:  $(A) \leftarrow (L)$

Flags: SF : Set to one  
SL : Unaffected

Example: MOV       L,#3H               ; Move 3H to REG L  
          MOV       A,L               ; Move 0H to A

**MOV @HL,A**

Binary Code: 

0 0 1 0	0 1 1 1
---------	---------

Description: The contents of the accumulator are moved to the data memory whose address is specified by registers H and L.  
The contents of the source operand are not affected.

Operation:  $M [(H,L)] \leftarrow (A)$

Flags: SF : Set to one  
SL : Unaffected

Example: CLR        A                   ; Clear the contents of A  
          MOV       H,#0H             ; Move 0H to REG H  
          MOV       L,#3H             ; Move 3H to REG L  
          MOV       @HL,A             ; Move 0H to RAM address 03H



**MOV A,@HL**

Binary Code: 

0 0 1 0	0 0 0 1
---------	---------

Description: The contents of the data memory addressed by registers H and L are moved to accumulator.  
The contents of the source operand are not affected.

Operation:  $(A) \leftarrow M[(H,L)]$

Flags: SF : Set to one  
SL : Unaffected

Example: Assume HL contains 04H  

MOV	A,@HL	; Move contents of RAM addressed 04H to A
-----	-------	---

**MOV L,@HL**

Binary Code: 

0 0 1 0	0 0 1 0
---------	---------

Description: The contents of the data memory addressed by registers H and L are moved to register L.  
The contents of the source operand are not affected.

Operation:  $(L) \leftarrow M[(H,L)]$

Flags: SF : Set to one  
SL : Unaffected

Example: Assume HL contains 04H  

MOV	L,@HL	; Move contents of RAM address 4H to REG L
CPNE	L,#5H	; Compare 5H to REG L values
JP	XX	; jump to XX if REG L value is not 5H
JP	YY	; Jump to YY if REG L value is 5H

**MOV @HL+,A**

Binary Code: 

0 0 1 0	0 1 0 1
---------	---------

Description: The contents of the accumulator are moved to the data memory addressed by registers H,L;  
L register contents are incremented by one.  
The contents of the source operand are not affected.

Operation:  $M[(H,L)] \leftarrow (A), L \leftarrow L + 1$

Flags: SF : Set if carry occurs; cleared otherwise  
SL : Unaffected

Example: 

MOV	H,#0H	
MOV	L,#0FH	
CLR	A	
MOV	@HL+A	; Move 0H to RAM address 0FH and increment REG L value by one
JP	PRT	; jump to PRT, since there is a carry from increment

**MOV @HL-A**Binary Code: 

0 0 1 0	0 1 0 0
---------	---------

Description: The contents of accumulator are moved to the data memory addressed by registers H,L;  
L register contents are decremented by one.  
The contents of the source operand are not affected.

Operation:  $M[(H,L)] \leftarrow (A), L \leftarrow L - 1$ 

Flags: SF : Set if no borrow; cleared otherwise  
SL : Unaffected

Example: MOV H,#0H  
MOV L,#3H  
CLR A  
MOV @HL-,A  
JP ABC

**MOV L,#N**Binary Code: 

0 1 0 0	d d d d
---------	---------

Description: The 4-bit value specified by n (data) is loaded into register L.  
The contents of the source operand are not affected.

Operation:  $(L) \leftarrow \#n$ 

Flags: SF : Set to one  
SL : Unaffected

Example: MOV L,#8H ; 8H is moved to REG L

**MOV H,#n**Binary Code: 

0 0 1 0	1 d d d
---------	---------

Description: The 3-bit value specified by n (data) is moved to register H.  
The contents of the source operand are not affected.

Operation:  $(H) \leftarrow \#n$ 

Flags: SF : Set to one  
SL : Unaffected

Example: MOV H,#4H ; 4H is moved into REG H

**MOV @HL+,#n**

Binary Code:	<table border="1"><tr><td>0 1 1 0</td><td>d d d d</td></tr></table>	0 1 1 0	d d d d
0 1 1 0	d d d d		
Description:	The 4-bit value specified by n (data) is moved to data memory addressed by registers H,L; L register contents are incremented by one. The contents of the source operand are not affected.		
Operation:	$M [(H,L)] \leftarrow \#n, L \leftarrow L + 1$		
Flags:	SF : Set to one SL : Unaffected		
Example:	MOV H,#0H MOV L,#7H MOV @HL+,#9H ; Move 9H to RAM address 07H and increment REG L value by one, then REG L contains 8H		

**MOVZ @HL,A**

Binary Code:	<table border="1"><tr><td>0 0 1 0</td><td>0 1 1 0</td></tr></table>	0 0 1 0	0 1 1 0
0 0 1 0	0 1 1 0		
Description:	The contents of the accumulator are moved to the data memory addressed by registers H,L; accumulator contents are cleared to zero.		
Operation:	$M [(H,L)] \leftarrow (A), (A) \leftarrow 0$		
Flags:	SF : Set to one SL : Unaffected		
Example:	MOV L,#3H MOV A,L MOVZ @HL,A ; Move 3H to indirect RAM and clear A to zero MOV L,A ; Move 0H to REG L SETB P2.(L) ; Set P2.0 to 1		

**XCH @HL,A**

Binary Code:	<table border="1"><tr><td>0 0 0 0</td><td>0 0 1 1</td></tr></table>	0 0 0 0	0 0 1 1
0 0 0 0	0 0 1 1		
Description:	This instruction exchanges the contents of the data memory addressed by registers H and L with the accumulator contents.		
Operation:	$M [(H,L)] \leftrightarrow (A)$		
Flags:	SF : Set to one SL : Unaffected		
Example:	MOV H,#0H MOV L,#6H CLR A ; Clear A to zero ADDS A,#5H ; Add 5H to A XCH @HL,A ; Exchange 5H with contents of RAM address 06H		

**PAGE #n**

Binary Code:	<table border="1"><tr><td>0 0 0 1</td><td>d d d d</td></tr></table>	0 0 0 1	d d d d
0 0 0 1	d d d d		
Description:	The immediate 4-bit value specified by n (data) is loaded into the PB register.		
Operation:	(PB) ← #n		
Flags:	SF : Set to one SL : Unaffected		
Example:	PAGE #3H ; Move 3H to page buffer JP AN ; Jump to label AN located at page 3 if SF is one; otherwise, it is skipped		

**CPNE @HL,A**

Binary Code:	<table border="1"><tr><td>0 0 0 0</td><td>0 0 0 0</td></tr></table>	0 0 0 0	0 0 0 0
0 0 0 0	0 0 0 0		
Description:	The contents of accumulator are compared to the contents of indirect data memory; an appropriate flag is set if their values are not equal. The contents of both operands are unaffected by the comparison.		
Operation:	M [(H,L)] ≠ (A)		
Flags:	SF : Set if not equal, cleared otherwise SL : Unaffected		
Example:	CLR A ADDS A,#3H MOV H,#0H MOV L,#6H CPNE @HL,A ; Acc value 3H is compared to contents of RAM address 06H JP OA ; Jump to OA if values of RAM address 06H are not 3h JP OB ; Jump to OB if values of RAM address 06H are 3H		

**CPNZ @HL**

Binary Code:

0 0 1 1	1 1 1 1
---------	---------

Description:

This instruction compares the magnitude of indirect data memory with zero, and the appropriate flag is set if their values are not equal, i.e., if the contents of indirect data memory are not zero.

The contents of operand are unaffected by the comparison.

Operation:

M [(H,L)] ≠ 0

Flags:

SF : Set if not zero, cleared otherwise

SL : Unaffected

Example:

Assume the contents of RAM address are 4H

CPNZ	@HL	; Compare 4H with zero
JP	EQ	; Jump to EQ because the result is not equal
JP	WAIT	

**CPNE L,A**

Binary Code:

0 0 0 0	0 0 1 0
---------	---------

Description:

The contents of the accumulator are compared to the contents of register L; the appropriate flags are set if their values are not equal.

The contents of both operands are unaffected by the comparison.

Operation:

(L) ≠ (A)

Flags:

SF : Set if not equal, cleared otherwise

SL : Set if not equal, cleared otherwise

Example:

Assume REG L contains 5H, A contains 4H

CPNE	L,A	; Compare A to REG L values
JP	K1	; Jump to K1 because the result is not equal
JP	K2	

**CPNE L,#n**

Binary Code:

0 1 0 1	d d d d
---------	---------

Description:

This instruction compare the immediate 4 bit data n with the contents of register L, and sets an appropriate flag if their values are not equal.  
The contents of both operands are unaffected by the comparison.

Operation:

(L) ≠ #n

Flags:

SF : Set if not equal, cleared otherwise  
SL : Unaffected

Example:

```
CLR      A
ADDS    A,#4H
MOV     L,A
CPNE   L,#5H      ; Compare immediate data 5H to REG L values
JP      K3        ; Jump to K3 because the result is not equal
```

**CPNE A,@HL**

Binary Code:

0 0 0 0	0 0 0 1
---------	---------

Description:

The contents of indirect data memory are compared to the contents of the accumulator. Appropriate flags are set if the contents of the accumulator are less than or equal to the contents of indirect data memory.  
The contents of both operands are unaffected by the comparison.

Operation:

(A) ≤ M [(H,L)]

Flags:

SF : Set if less than or equal to, cleared otherwise  
SL : Unaffected

Example:

```
Assume RAM address holds 8H
CPLE   A,@HL      ; Compare 8H to A values
JP     MAR        ; Jump to MAR if 0H ≤ A ≤ 8H
JP     BPR        ; Jump to BPR if 9H ≤ A ≤ 0FH
```

**CPNZ P0**

Binary Code:

0 0 0 0	1 1 1 0
---------	---------

Description:

The instruction compares the contents of Port 0 with zero. Appropriate flags are set if their values are not equal, i.e., if the contents of Port 0 are not zero. The contents of the operand are unaffected by the comparison.

Operation:

(P0) ≠ 0

Flags:

SF : Set if not zero, cleared otherwise  
SL : Unaffected

Example:

```
MOV      L,#0DH
CLRB    P2.(L)      ; Clear P2.13, i.e., select P0 input
CPNZ    P0          ; Compare P0 to zero
JP      KEYIN       ; Jump to KEYIN if P0 ≠ 0
JP      NOKEY       ; Jump to NOKEY if P0 = 0
```

**CPBT @HL,b**

Binary Code:

0 0 1 1	1 0 d d
---------	---------

Description:

CPBT tests indirect data memory bit and sets appropriate flags if the bit value is one. The contents of operand are unaffected by the test.

Operation:

M [(H,L)] = 1

Flags:

SF : Set if one, cleared otherwise  
SL : Unaffected

Example:

```
MOV      H,#0H
MOV      L,#0BH
CPBT    @HL,3      ; Test RAM address 0BH bit 3
JP      Q1         ; Jump to Q1 if RAM address bit 3 is 1
JP      Q2         ; Jump to Q2 if RAM address bit 3 is 0
```

**JP dst**Binary Code: 

1 0 d d	d d d d
---------	---------

Description: The JP transfers program control to the destination address if the SF is one. The conditional jump replaces the contents of the program counter with the address indicated and transfers control to that location.  
Had the SF flag not been set, control would have proceeded with the next instruction.

Operation: If SF = 1 ; PC  $\leftarrow$  (W), PA  $\leftarrow$  PBFlags: SF : Set to one  
SL : Unaffected

Example: JP SUTIN1 ; This instruction will cause program execution to branch to the instruction at label SUTIN; SUTIN1 must be within the current page

**CALL dst**Binary Code: 

1 1 d d	d d d d
---------	---------

Description: If the SF flag is set to 1, this instruction calls a subroutine located at the indicated address, and then pushes the current contents of the program counter to the top of the stack. The program counter value used is the address of the first instruction following the CALL ins. The specified destination address is then loaded into the program counter and points to the first instruction of a procedure. At the end of the procedure, the return (RET) instruction can be used to return to the original program flow.

Operation: If SF = 1 ; SRi  $\leftarrow$  PC + 1, PSRi  $\leftarrow$  PA  
PC  $\leftarrow$  I (W), PA  $\leftarrow$  PBFlags: SF : Set to one  
SL : Unaffected

Example: CALL ACD1 ; CALL subroutine located at the label ACD1 where ACD1 must be within the current page

**RET**Binary Code: 

0 0 0 0	1 1 1 1
---------	---------

Description: This instruction is normally used to return to the previously executing procedure at the end of a procedure entered by a CALL instruction. The contents of the location addressed by the stack pointer are popped into the program counter. The next statement executed is that addressed by the new contents of the program counter.

Operation: PC  $\leftarrow$  Sri, PB  $\leftarrow$  PSRi  
PA  $\leftarrow$  PBFlags: SF : Set to one  
SL : Unaffected

Example: RET ; Return from subroutine



**SETB P2.(L)**

Binary Code:	<table border="1"><tr><td>0 0 0 0</td><td>1 1 0 1</td></tr></table>	0 0 0 0	1 1 0 1
0 0 0 0	1 1 0 1		
Description:	This instruction sets the Port 2 bit addressed by register L without affecting any other bits in the destination.		
Operation:	$P2.(L) \leftarrow 1$		
Flags:	SF : Set to one SL : Unaffected		
Example:	MOV       L,#0H SETB       P2.(L)               ; Set P2.0 to 1		

**CLRB P2.(L)**

Binary Code:	<table border="1"><tr><td>0 0 0 0</td><td>1 1 0 0</td></tr></table>	0 0 0 0	1 1 0 0
0 0 0 0	1 1 0 0		
Description:	This instruction clears the Port 2 bit addressed by register L without affecting any other bits in the destination.		
Operation:	$P2.(L) \leftarrow 0$		
Flags:	SF : Set to one SL : Unaffected		
Example:	MOV       L,#0H CLRB       P2.(L)               ; Clear P2.0 to 0		

**IN A,P0**

Binary Code:	<table border="1"><tr><td>0 0 0 0</td><td>1 0 0 0</td></tr></table>	0 0 0 0	1 0 0 0
0 0 0 0	1 0 0 0		
Description:	Data present on Port n is transferred (read) to the accumulator.		
Operation:	$(A) \leftarrow (Pn) (n = 0,1)$		
Flags:	SF : Set to one SL : Unaffected		
Example:	IN        A,P0               ; Input port 0 data to Acc MOV       L,A CPNE     L,#3H JP        OX               ; Jump to OX if port 0 data $\neq$ 3H JP        QP               ; Jump to QP if port 0 data = 3H		

**OUT P3,@SL+A**Binary Code: 

0 0 0 0	1 0 1 0
---------	---------

Description: The contents of the accumulator and SL are transferred to the P3 Output register.

Operation: (P3 Output register)  $\leftarrow$  (A) + (SL)Flags: SF : Set to one  
SL : UnaffectedExample: CLR A  
OUT P3,@SL+A ; Zero output on port 3**NOTI A**Binary Code: 

0 0 1 1	1 1 0 1
---------	---------

Description: The contents of the accumulator are complemented; all 1 bits are changed to 0, and vice-versa, and then incremented by one.

Operation: (A)  $\leftarrow$  (A), (A)  $\leftarrow$  (A) + 1Flags: SF : Set if the result is zero, cleared otherwise  
SL : UnaffectedExample: CLR A  
ADDS A,#7H  
NOTI A ; Complement 7H (0111B) and increment the result by one;  
the instruction NOTI A then leaves 9H (1001B) in A

**NOT H**

Binary Code:	<table border="1"><tr><td>0 0 0 0</td><td>1 0 0 1</td></tr></table>	0 0 0 0	1 0 0 1
0 0 0 0	1 0 0 1		
Description:	The MSB of register H is complemented,		
Operation:	$(H) \leftarrow (\bar{H})$		
Flags:	SF : Set to one SL : Unaffected		
Example:	MOV H,#4H NOT H ; Complement 4H (100B), then it leaves 00H (000B) in REG H		

**CLR A**

Binary Code:	<table border="1"><tr><td>0 1 1 1</td><td>1 1 1 1</td></tr></table>	0 1 1 1	1 1 1 1
0 1 1 1	1 1 1 1		
Description:	The contents of the accumulator are cleared to zero (all bits set on zero).		
Operation:	$(A) \leftarrow 0$		
Flags:	SF : Set to one SL : Unaffected		
Example:	CLR A ; A value are cleared to zero		

**ADDS A,@HL**

Binary Code:	<table border="1"><tr><td>0 0 0 0</td><td>0 1 1 0</td></tr></table>	0 0 0 0	0 1 1 0
0 0 0 0	0 1 1 0		
Description:	ADDS adds the contents of indirect data memory to accumulator, leaving the result in the accumulator. The contents of the source operand are unaffected.		
Operation:	$(A) \leftarrow M[(H,L)] + (A)$		
Flags:	SF : Set if a carry occurred, cleared otherwise SL : Unaffected		
Example:	Assume RAM address holds 5H CLR A ; Clear A to zero ADDS A,@HL ; This instruction will leaves 5H in A		

**ADDS A,#n**

Binary Code: 

0 1 1 1	d d d d
---------	---------

Description: The specified 4-bit data n is added to the accumulator and the sum is stored in the accumulator.

Operation:  $(A) \leftarrow (A) + \#n$

Flags: SF : Set if a carry occurred, cleared otherwise  
SL : Unaffected

Example: CLR A ; Clear A to zero  
ADDS A,#4H ; Add 4H to A, it leaves 4H in A

**SUBS A,@HL**

Binary Code: 

0 0 1 1	1 1 0 0
---------	---------

Description: SUBS subtracts the contents of accumulator from the contents of indirect data memory, leaving the result in the accumulator.  
The contents of source operand are unaffected.

Operation:  $(A) \leftarrow M[(H,L)] - (A)$

Flags: SF : Set if no borrow occurred, cleared otherwise  
SL : Unaffected

Example: Assume RAM address holds 0CH  
MOV L,#8H  
MOV A,L  
SUBS A,@HL ; Subtract A from 0CH; it will leave 4H in A

**INCS A,@HL**

Binary Code: 

0 0 1 1	1 1 1 0
---------	---------

Description: The contents of indirect data memory are incremented by one and the result is loaded into the accumulator.  
The contents of indirect data memory are unaffected.

Operation:  $(A) \leftarrow M[(H,L)] + 1$

Flags: SF : Set if a carry occurred, cleared otherwise  
SL : Unaffected

Example: Assume RAM address holds 6H  
CLR A ; Clear A to zero  
INCS A,@HL ; Increment 6H by one and leave 7H in A

**INCS L**

Binary Code: 

0 0 0 0	0 1 0 1
---------	---------

Description: The contents of the L register are incremented by one.

Operation:  $(L) \leftarrow (L) + 1$

Flags: SF : Set if a carry occurred, cleared otherwise  
SL : Unaffected

Example: `MOV L,#5H`  
`INCS L ; Increment REG L value 5H by one`

---

**INCS A**

Binary Code: 

0 1 1 1	0 0 0 0
---------	---------

Description: The contents of the accumulator are incremented by one.

Operation:  $(A) \leftarrow (A) + 1$

Flags: SF : Set if no borrow occurred, cleared otherwise  
SL : Unaffected

Example: `MOV L,#5H`  
`MOV A,L`  
`INCS A ; Increment 5H by one`

---

**DECS A**

Binary Code: 

0 1 1 1	0 1 1 1
---------	---------

Description: The contents of the accumulator are decremented by one.

Operation:  $(A) \leftarrow (A) - 1$

Flags: SF : Set if a carry occurred, cleared otherwise  
SL : Unaffected

Example: `MOV L,#0BH`  
`MOV A,L`  
`DECS A ; The instruction leaves the value 0AH in A`

---

**DECS A,@HL**Binary Code: 

0 0 0 0	0 1 1 1
---------	---------

Description: The contents of the data memory addressed by the H and L registers are decremented by one and the result is loaded in the accumulator.  
But the contents of data memory are not affected.Operation:  $(A) \leftarrow M[(H,L)] - 1$ Flags: SF : Set if a carry occurred, cleared otherwise  
SL : Unaffected

Example: Assume RAM address holds 5h

MOV L,#0AH

MOV A,L

DECS A,@HL ; Decrement the value 5H by one, and the result value 4H is loaded in A

**DECS L**Binary Code: 

0 0 0 0	0 1 0 0
---------	---------

Description: The contents of the L register are decremented by one.

Operation:  $(L) \leftarrow (L) - 1$ Flags: SF : Set if no borrow occurred, cleared otherwise  
SL : Unaffected

Example: MOV L,#3H

DECS L ; This instruction leaves the value 2H in REG L

**SETB @HL,b**Binary Code: 

0 0 1 1	0 0 d d
---------	---------

Description: This instruction sets indirect data memory bit addressed by registers H and L without affecting any other bits in the destination.

Operation:  $b \leftarrow 1$  (b = 0,1,2,3)Flags: SF : Set to one  
SL : Unaffected

Example: MOV H,#0H

MOV L,#5H

SETB @HL.2 ; Set RAM address 05H bit 2 to 1

**DECS A,@HL**

Binary Code:	<table border="1"><tr><td>0</td><td>0</td><td>1</td><td>1</td></tr><tr><td>0</td><td>1</td><td>d</td><td>d</td></tr></table>	0	0	1	1	0	1	d	d
0	0	1	1						
0	1	d	d						
Description:	This instruction clears the indirect data memory bit addressed by registers H and L without affecting any other bits in the destination.								
Operation:	$b \leftarrow 1$ (b = 0,1,2,3)								
Flags:	SF : Set to one SL : Unaffected								
Example:	MOV H,#0H MOV L,#5H CLRB @HL.3 ; Clear RAM address 05H bit 3 to zero								

## **6. DEVELOPMENT TOOLS**





## SMDS

The Samsung Microcontroller Development System, SMDS is a complete PC-based development environment for S3C1840/C1850/C1860 microcontroller. The SMDS is powerful, reliable, and portable. The SMDS tool set includes a versatile debugging utility, trace with built-in logic analyzer, and performance measurement applications.

Its window-oriented program development structure makes SMDS easy to use. SMDS has three components:

- IBM PC- compatible SMDS software, all device-specific development files, and the SAMA assembler.
- Development system kit including main board, personality board, SMDS manual, and target board adapter, if required.
- Device-specific target board.

## SMDS PRODUCT VERSIONS

As of the date of this publication, two versions of the SMDS are being supported:

- SMDS Version 4.8 (S/W) and SMDS Version 3.6 (H/W); last release: January, 1994.
- SMDS2 Version 5.3 (S/W) and SMDS2 Version 1.3 (H/W); last release: November, 1995.

The new SMDS2 Version 1.3 is intended to replace the older Version 3.6 SMDS. The SMDS2 contains many enhancements to both hardware and software. These development systems are also supported by the personality boards of Samsung's microcontroller series: S3C1, S3C7, and S3C8.

## SAMA ASSEMBLER

The Samsung Arrangeable Microcontroller (SAM) Assembler, SAMA, is a universal assembler, and generates object code in standard hexadecimal format.

Compiled program code includes the object code that is used for ROM data and required SMDS program control data. To compile programs, SAMA requires a source file and an auxiliary definition (DEF) file with device-specific information.

## TARGET BOARDS AND PIGGYBACKS

Target boards are available for S3C1840/C1850/C1860 microcontroller. All required target system cables and adapters are included with the device-specific target board.

Piggyback chips are provided to customers in limited quantities for S3C1840/C1850 microcontroller. The S3C1840/C1850 piggyback chips, PB51840-20 and PB51840/51850-24 are now available.

PB51840-20 is 20 DIP piggyback chip for 20 DIP, 20 SOP package device of S3C1840 microcontroller.  
 PB51840/51850-24 is 24DIP piggyback chip for 24 SOP package device of S3C1840/C1850 microcontroller.

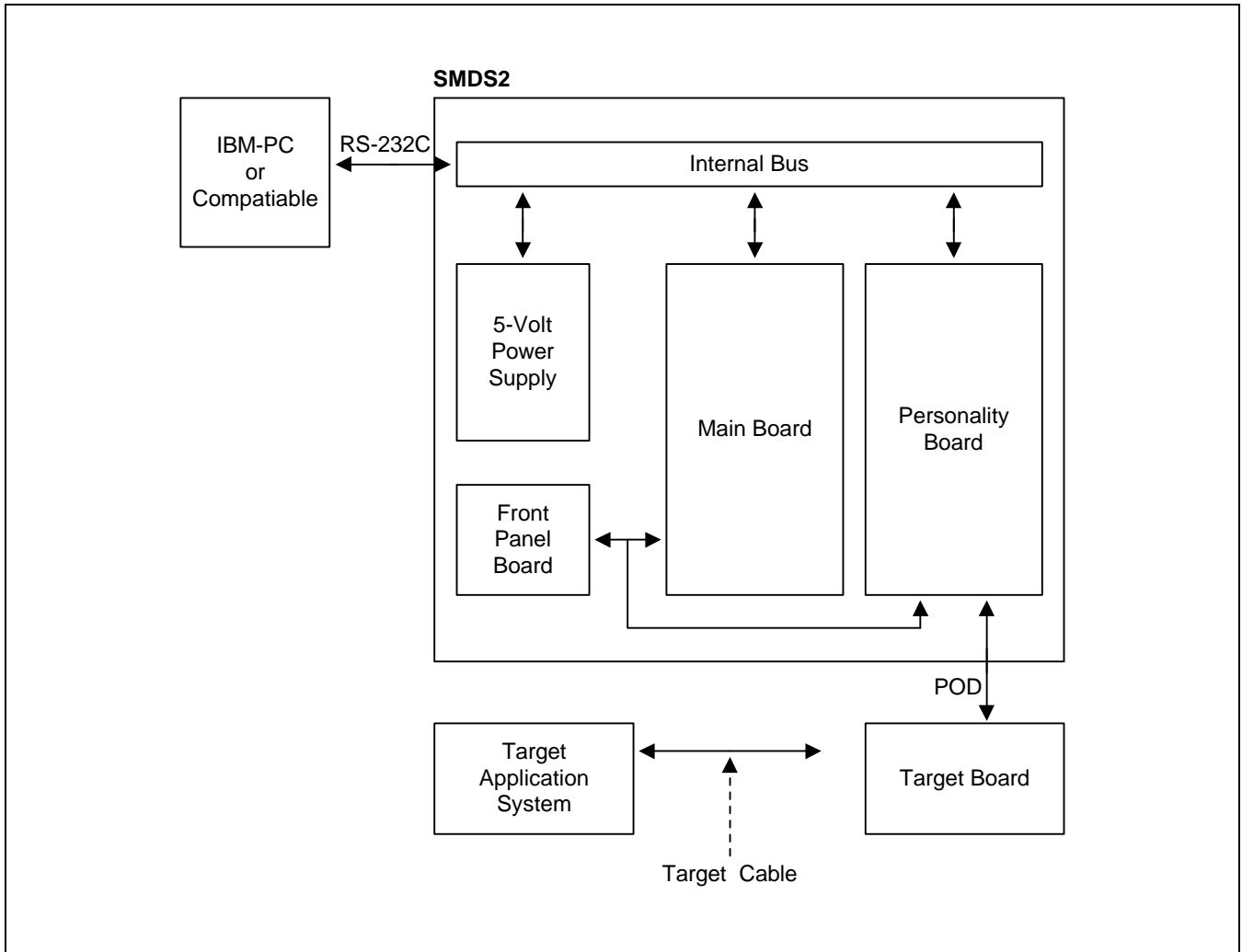
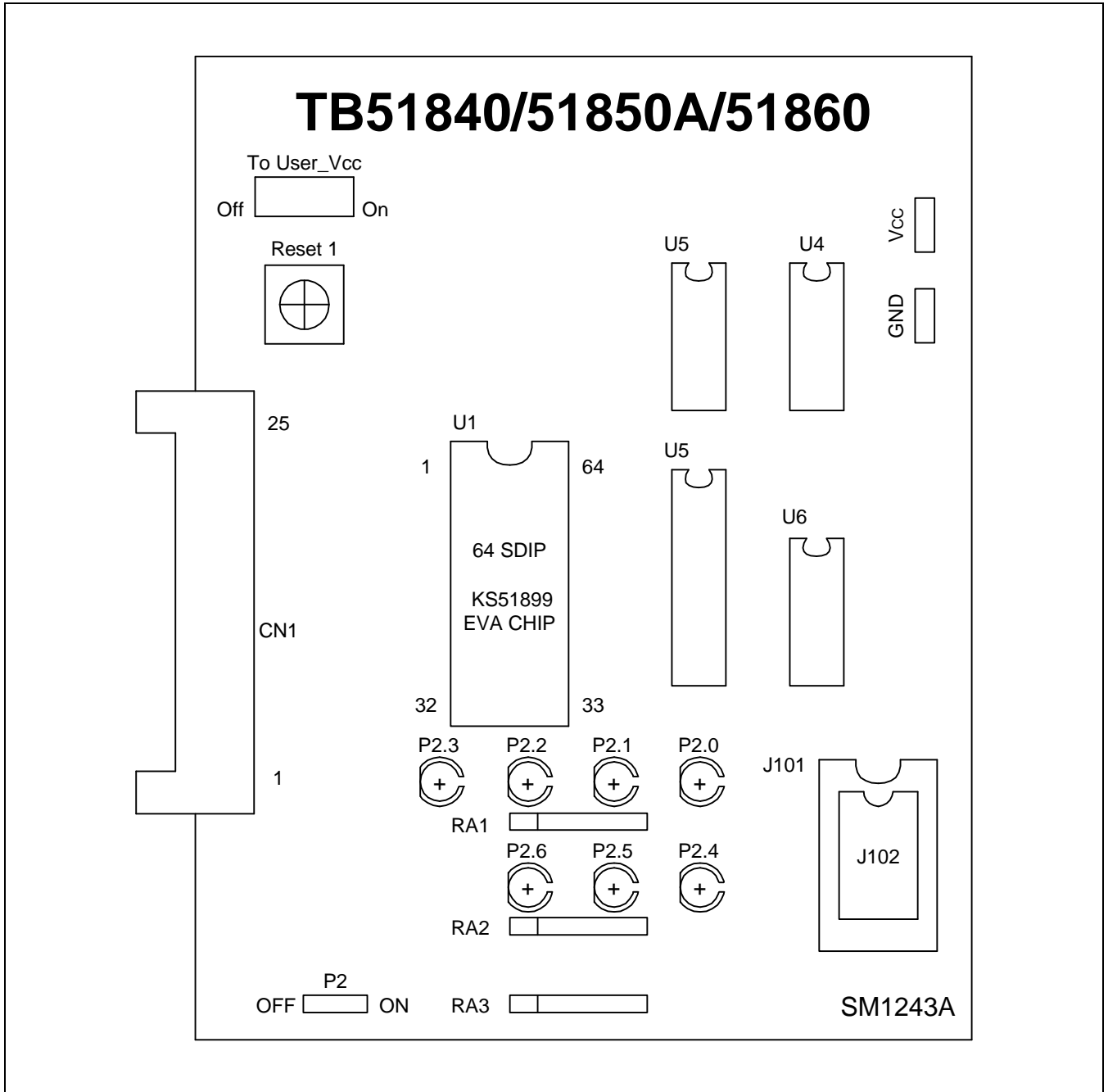

Figure 6-1. SMDS Product Configuration (SMDS2)

**TB51840/51850A TARGET BOARD**

The TB51840/51850A target board is used for the S3C1840/C1850/C1860 microcontroller. It is supported by the SMDS2 development system only.



**Figure 6-2. TB51840/51850A Target Board Configuration**

**Table 6-1. Power Selection Settings for TB51840/51950A**

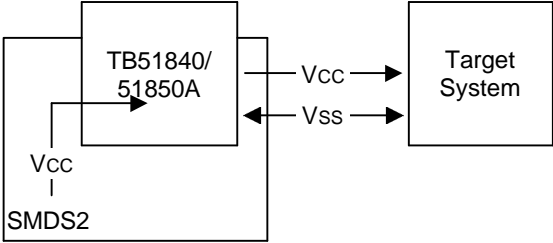
'To User_Vcc' Settings	Operating Mode	Comments
<p>To User_Vcc OFF <input type="checkbox"/> <input checked="" type="checkbox"/> <input type="checkbox"/> ON</p>	 <p>The diagram shows a box labeled 'TB51840/51850A'. A line labeled 'Vcc' goes from 'SMDS2' to the chip. Two lines labeled 'Vcc' and 'Vss' go from the chip to a box labeled 'Target System'.</p>	<p>The SMDS2 supplies <math>V_{CC}</math> to the target board (evaluation chip) and the target system.</p>
<p>To User_Vcc OFF <input checked="" type="checkbox"/> <input type="checkbox"/> <input type="checkbox"/> ON</p>	 <p>The diagram shows a box labeled 'TB51840/51850A'. A line labeled 'Vcc' goes from 'SMDS2' to the chip. Two lines labeled 'External Vcc' and 'Vss' go from the chip to a box labeled 'Target System'.</p>	<p>The SMDS2 supplies <math>V_{CC}</math> only to the target board (evaluation chip). The target system must have its own power supply.</p>

**LED 2.0-LED 2.6:**

These LEDs are used to display value of the P2.0-P2.6. It will be turn on, if the value is Low.

**P2 Option Switch:**

Switch ON: You can see the port value using the LED display.

Switch OFF: You can't see the port value. That is, the LED won't be turn ON by the port value.

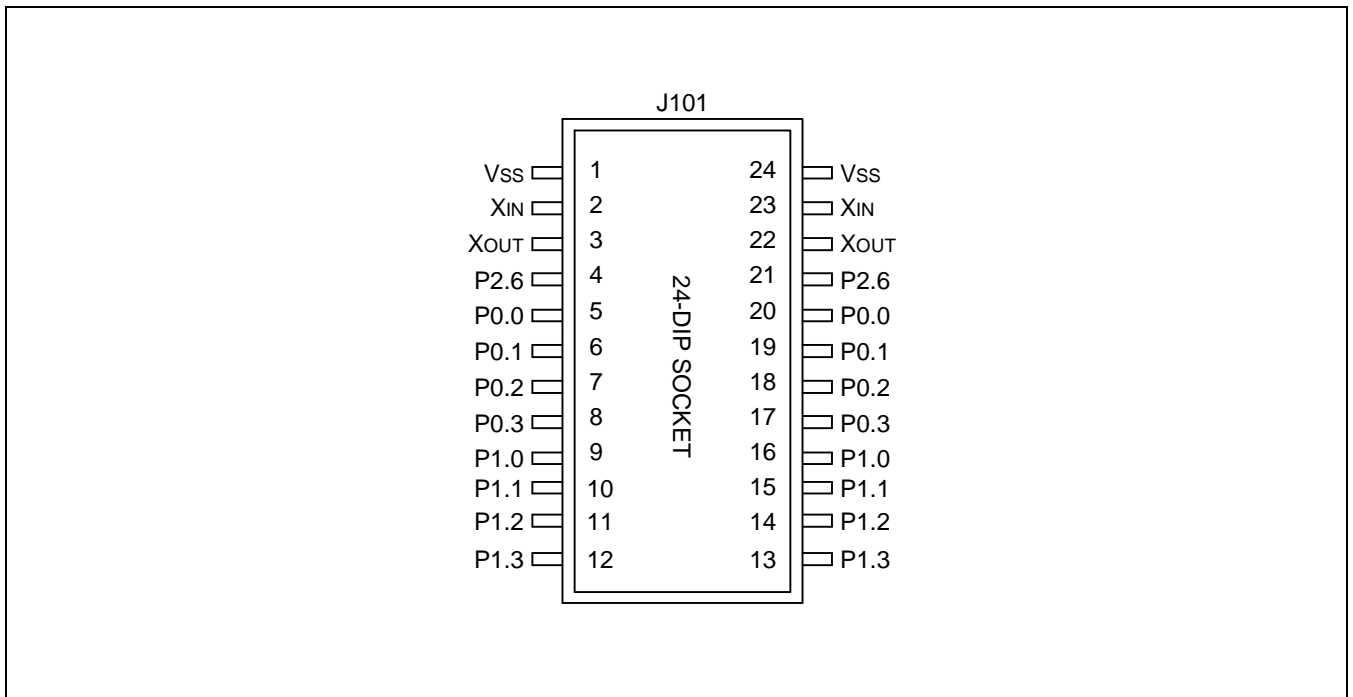

Figure 6-3. 24 DIP Socket for TB51840/51850A (S3C1840/C1850, 24 SOP)

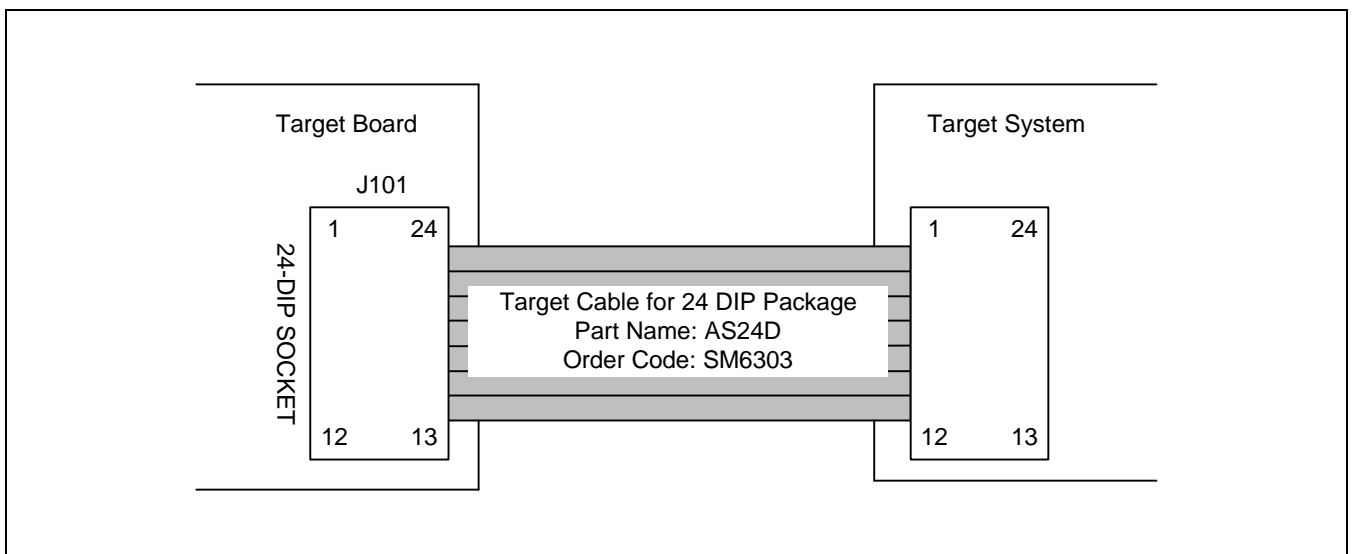

Figure 6-4. TB51840/51850A Cable for 24 DIP Package

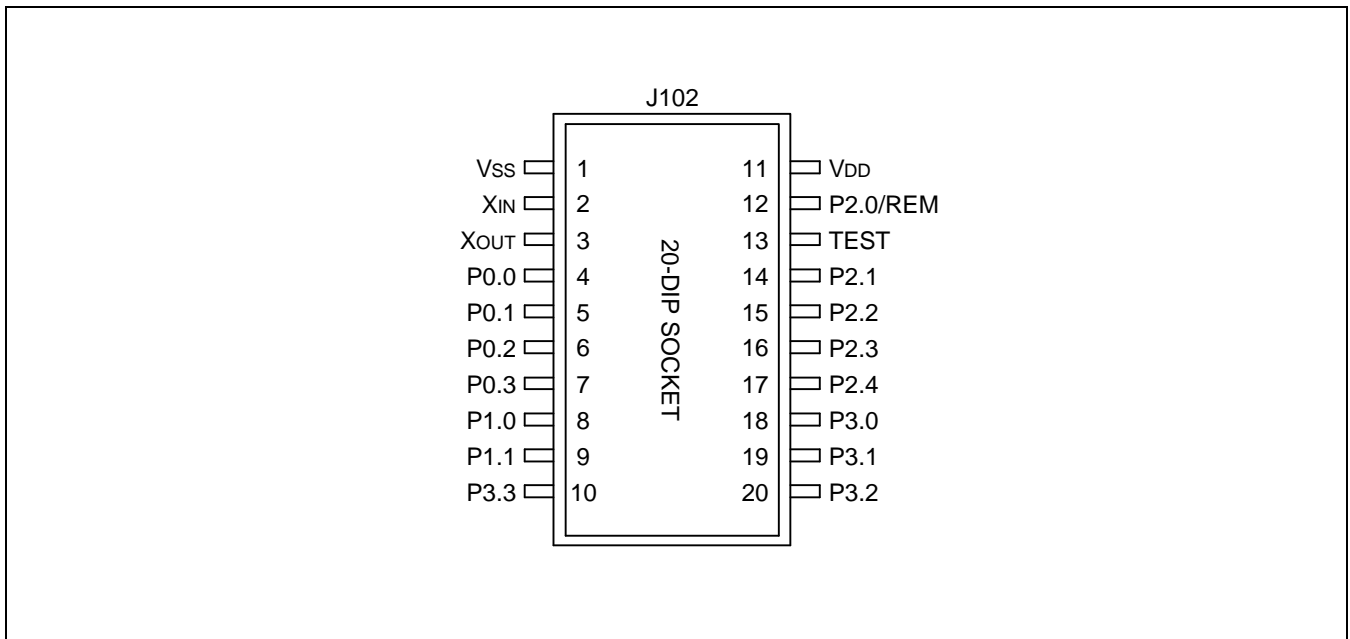

Figure 6-5. 20 DIP Socket for TB51840A (S3C1840/C1860, 20 DIP, 20 SOP)

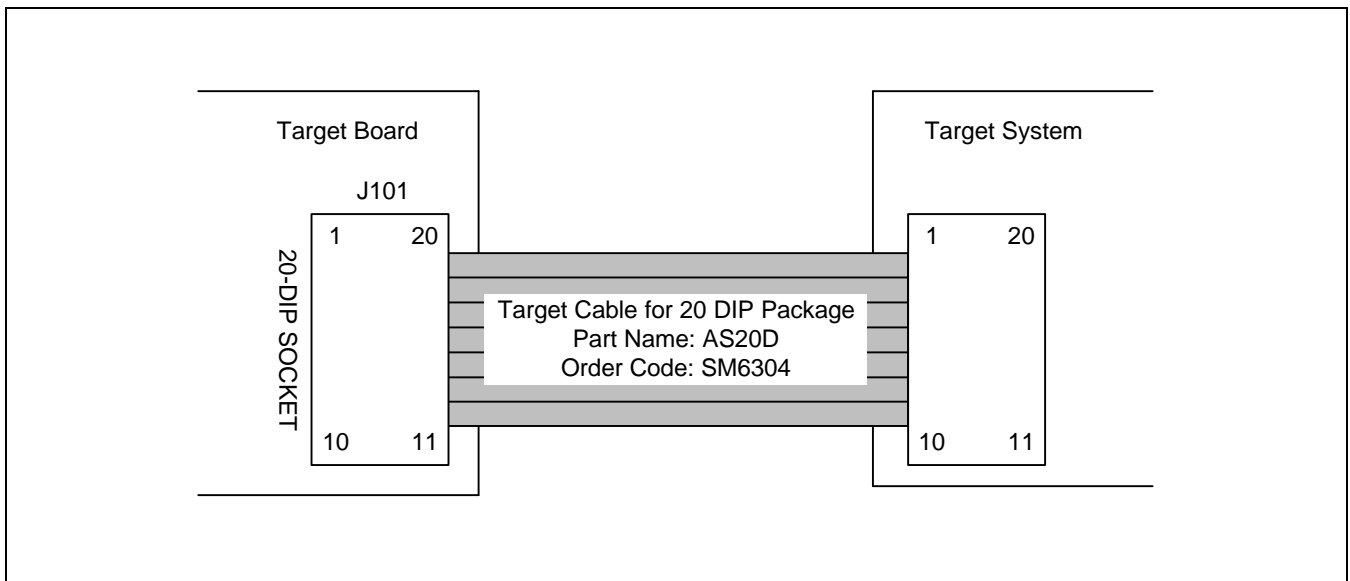

Figure 6-6. TB51840A Cable for 20 DIP Package

## **7. REMOTE CONTROL Tx. APPLICATION NOTE**





## DESCRIPTION OF THE S3C1840/C1850/C1860 MCUS

The S3C1840/C1850/C1860 4-bit single-chip CMOS microcontroller is designed using the reliable SMCS-51 CPU core with on-chip ROM and RAM. An auto-reset circuit generates a RESET pulse in regular intervals, and can be used to initiate a Halt mode release. The S3C1840/C1850/C1860 microcontroller is intended for use in small system control applications that require a low-power and cost-sensitive design solution. In addition, the S3C1840/C1850/C1860 has been optimized for remote control transmitters.

### FEATURES

Table 7-1. S3C1840/C1850/C1860 Features

Feature	S3C1840	S3C1850	S3C1860
ROM	1024 bytes	1024 bytes	1024 bytes
RAM	32 x 4 bits	32 x 4 bits	32 x 4 bits
Carrier frequency	fx/12, fx/8, no carrier	fx/12, fx/8, no carrier	fx/12, fx/8, no carrier
Operating voltage	250 kHz ≤ f <sub>OSC</sub> ≤ 3.9 MHz 1.8 V to 3.6 V, 3.9 MHz < f <sub>OSC</sub> < 6 MHz 2.2 V to 3.6 V	250 kHz ≤ f <sub>OSC</sub> ≤ 3.9MHz 1.8 V to 3.6 V, 3.9 MHz < f <sub>OSC</sub> < 6 MHz 2.2 V to 3.6 V	250 kHz ≤ f <sub>OSC</sub> ≤ 3.9 MHz 1.8 V to 3.6 V, 3.9 MHz < f <sub>OSC</sub> < 6 MHz 2.2 V to 3.6 V
Low-Level Output Current P2.0 (IOL1)	Typ. 3.0mA (at VO=0.4V)	Typ. 210mA (at VO=0.4V) Typ. 260mA (at VO=0.5V)	Typ. 280mA (at VO=0.4V) Typ. 320mA (at VO=0.5V)
Package	24 SOP, 20 SOP/DIP	24 SOP	20 SOP/DIP
Piggyback	O	O	x
OTP	x	x	O (S3P1860:divide-8 only)
Tr. for I.R.LED drive	x	Built-in	Built-in
Power on reset circuit	Built-in	Built-in	x
Oscillation Start and reset circuit (OSR)	x	x	Built-in

Table 7-2. S3C1840/C1850/C1860 Package Types <sup>(note)</sup>

Item	24 pins	20 pins
Package	24 SOP-375	20 DIP-300A 20 SOP-300 20 SOP-375

**NOTE :** The S3C1850 has 24 pin package type only and S3C1860/S3P1860 has 20 pin package type only.

**Table 7-3. S3C1840/C1850/C1860 Functions**

	Description
Automatic reset by Halt mode release	When Halt mode is released, the chip is reset after an oscillator stabilization interval of 9 ms. (f <sub>xx</sub> = 455 kHz)
Output pin state retention function	When the system enters Halt Mode, P3.0-P3.3, P2.0, and P2.2-P2.5 go low level in 24 pins. P3.0-P3.3, P2.0, and P2.2-P2.4 go low level in 20 pins. <b>But the P2.0 is floating state in S3C1850/C1860. (NOTE)</b>
Auto-reset	With oscillation on and with no change to the IP2.0 output pin, a reset is activated every 288 ms at f <sub>xx</sub> = 455 kHz.
Osc. Stabilization time	CPU instructions are executed after oscillation stabilization time has elapsed.
Other functions	Carrier frequency generator. Halt wake-up function.

**NOTE :** The S3C1850 has 24 pin package type only and S3C1860 has 20 pin package type only.

**RESET**

The S3C1840/C1850 has three kinds of reset operations:

- POR (Power-On Reset)
- Auto-reset
- Automatic reset by Halt release

The S3C1860 has three kinds of reset operations;

- OSR (Oscillation Start and Reset)
- Auto-reset
- Automatic reset by Halt release

**Power-On Reset Circuits**

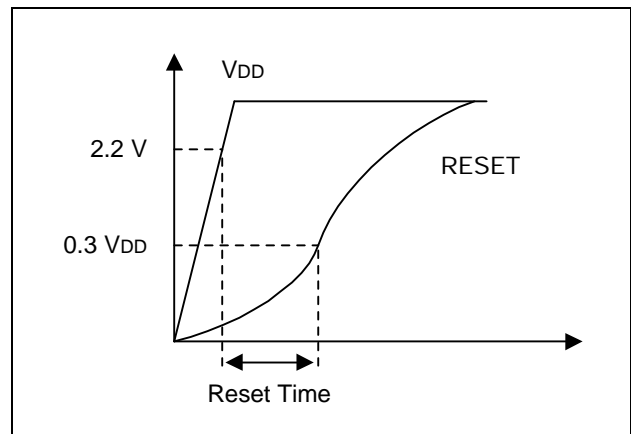
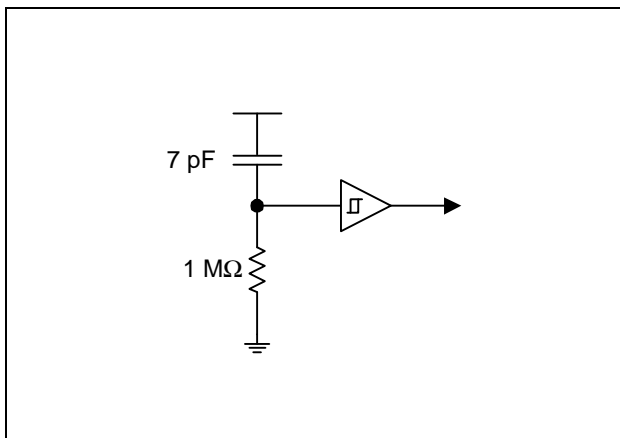

**Figure 7-1. Power-On Reset Circuits**

**Auto-Reset**

The auto-reset function resets the CPU every 131,072 oscillator cycles (288 ms at  $f_{xx} = 455$  kHz). The auto-reset counter is cleared when a rising edge is detected at IP2.0, or by a HALT or RESET pulse.

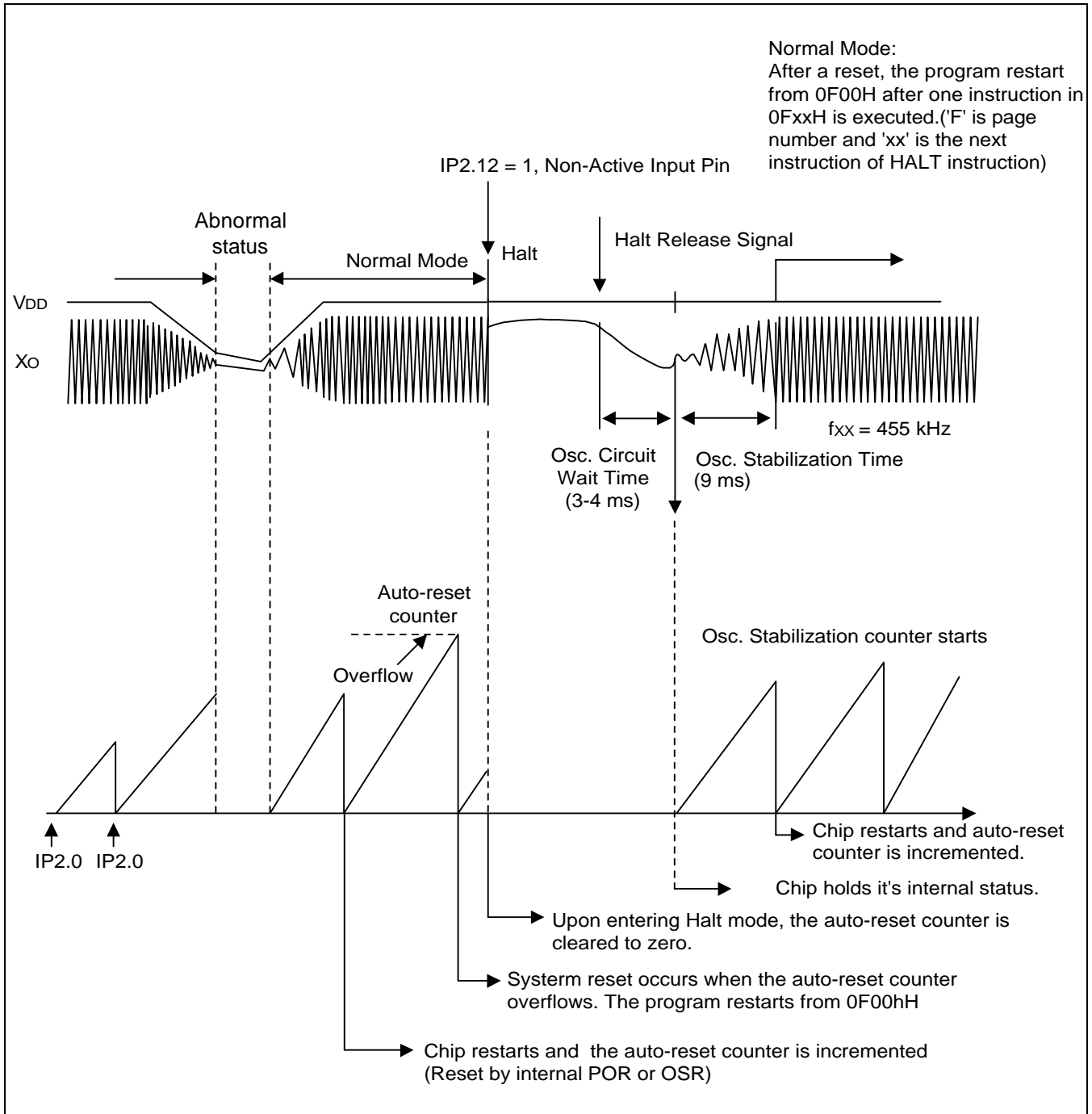

**Figure 7-2. Auto-Reset Counter Function**

**NOTE :** The OSR(Oscillation Start and reset) is not implemented for the S3C1840/C1850.

**Automatic Reset by Halt Mode Release**

This function resets the CPU by releasing Halt mode. The CPU is reset to its initial operating status and program execution starts from the reset address.

**Halt Mode and Automatic Reset by Halt Release**

Halt mode is used to reduce power consumption by stopping the oscillation and holding the internal state. Halt mode can be entered by forcing IP2.12 to high level (remaining input pins are non-active).

Before entering Halt mode, programmer should pre-set all key strobe output pins to active state even though Halt mode causes some pins to remain active.

For the 24 pins, P3.0-P3.3, P2.0, P2.2- P2.4, and P2.5 are sent low and for 20 pins, P3.0-P3.3, P2.0, P2.2-P2.4 are sent low, but the P2.0 is floating state in S3C1850/C1860.. Forcing any key input port to active state causes the clock oscillation logic to start system initialization.

At this time, the system is reset after the oscillation stabilization time elapses. A system reset causes program execution to start from address 0F00H.

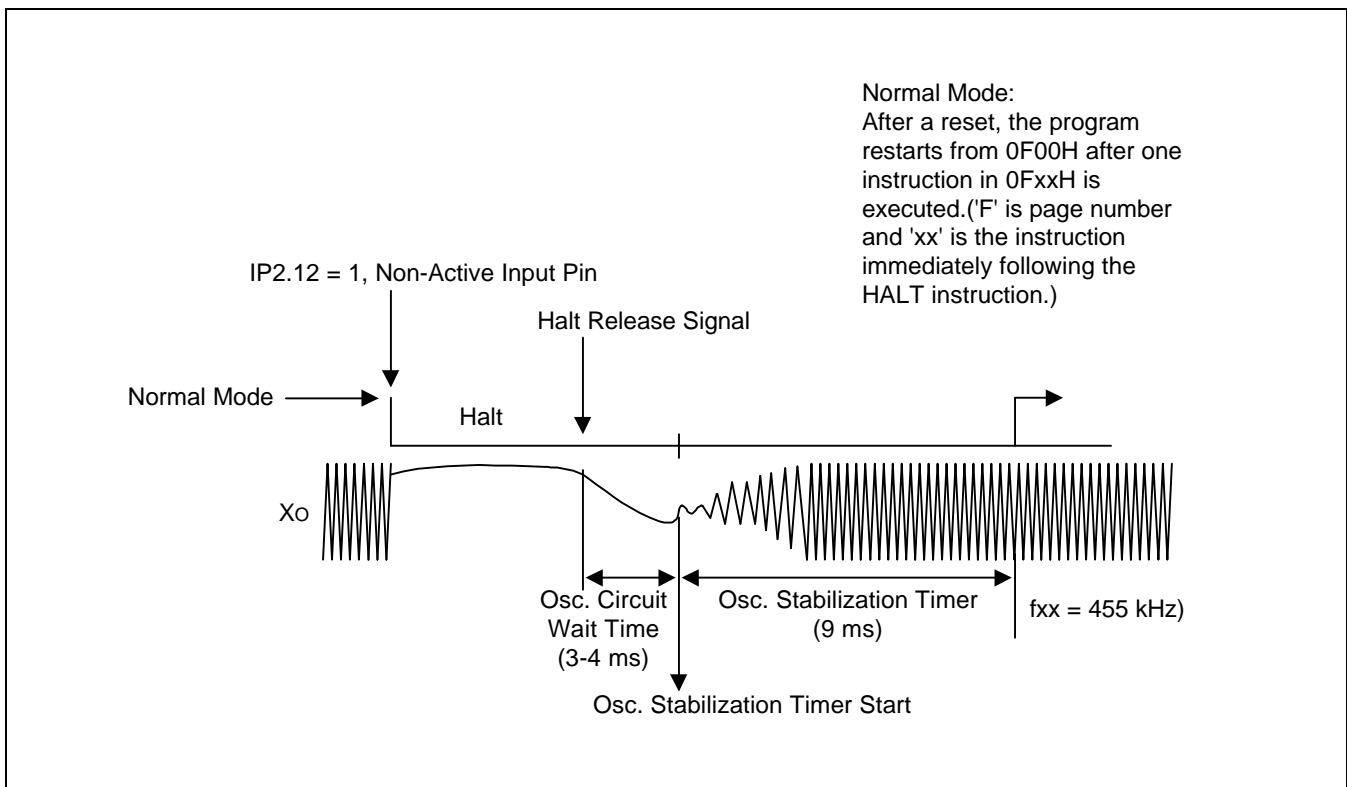

**Figure 7-3. Reset Timing Diagram**

**HALT mode programming**

The S3C1840/C1850/C1860 can enter Halt mode by setting the IP2.12 pin to high level and forcing P0 and P1 input to a normal state. If IP 2.12 is high and any input is active, the chip cannot enter Halt mode. Therefore, the next instruction is executed, which must be a clear command for IP2.12.

```

MOV L,#5
KEYOLO CLRB P2.(L) ; P2.5,4,3,2, ← Low
DECS L
CPNE L,#1
JP KEYOLO
CLR A ; Acc. ← #0h
OUT P3,@SL+A ; P3.0,1,2,3, ← Low
MOV L,#0DH
CLRB P2.(L) ; Select the P0 input
IN A,P0
INCS A ; P0 input check
JP .+2
JP KEYCHK ; If any key pressed in P0, jump to KEYCHK routine
SETB P2.(L) ; Select the P1 input
timea IN A,P0
INCS A ; P1 input check
JP + 2
timeb JP KEYCHK ; If any key pressed in P1, jump to KEYCHK routine
MOV L,#0CH ; No key pressed
SETB P2.(L) ; Halt mode

```

; When no key is pressed, the chip enters Halt mode. Pressing any key while in Halt mode causes the chip to be initialized and restarted from the reset address.

; If any key is pressed between time A and time B, the following instruction is executed.

```

MOV L,#0CH ; These two instructions remove the condition of re-entering
CLRB P2.(L) ; Halt mode.

```

RESET and HALT Logic Diagram

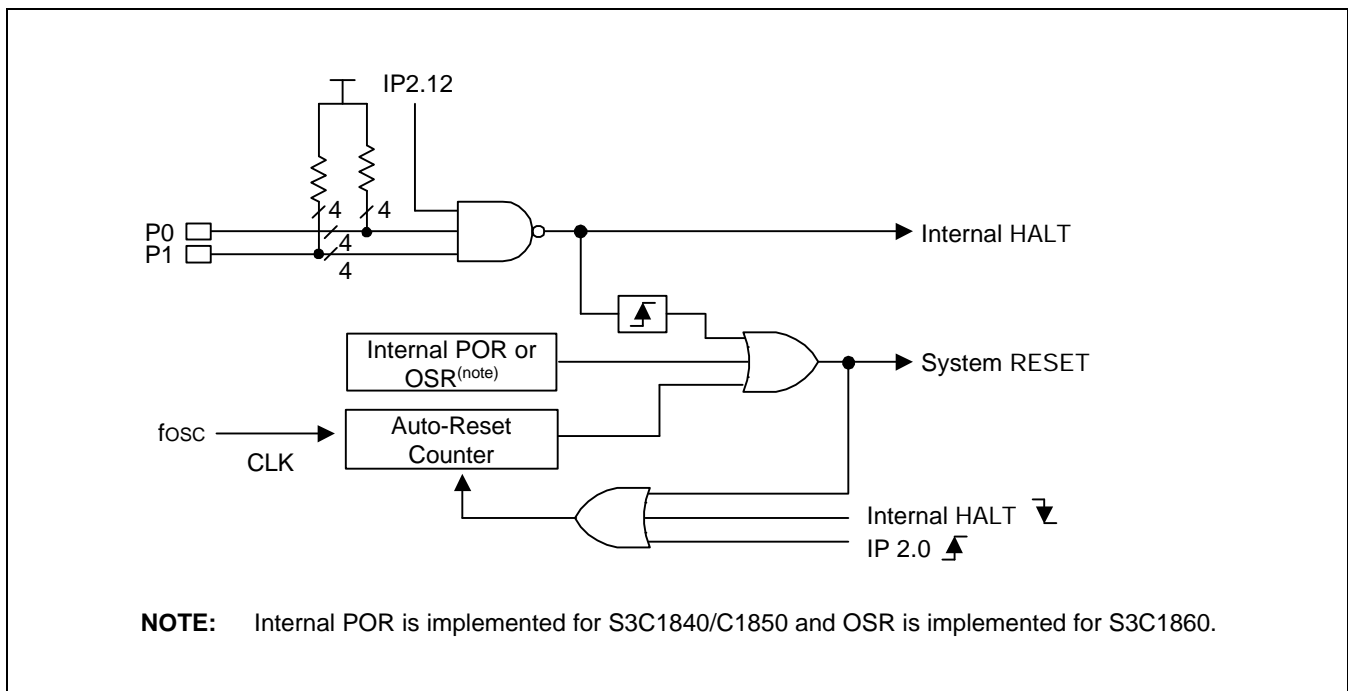

Figure 7-4. RESET and HALT Logic Diagram

## OUTPUT PIN DESCRIPTION

### Indicator LED Drive Output

To drive the indicator LED, the programmer should use P2.1 of the S3C1840/C1850/C1860 (which have higher current drive capability than other pins) in order to retain the pre-programmed status during Halt mode. Be careful to turn on the LED when a reset signal is generated. Because a reset signal sends all of the internal and external output pins to low level, the programmer must set LED output P2.1 to high state using a reset subroutine.

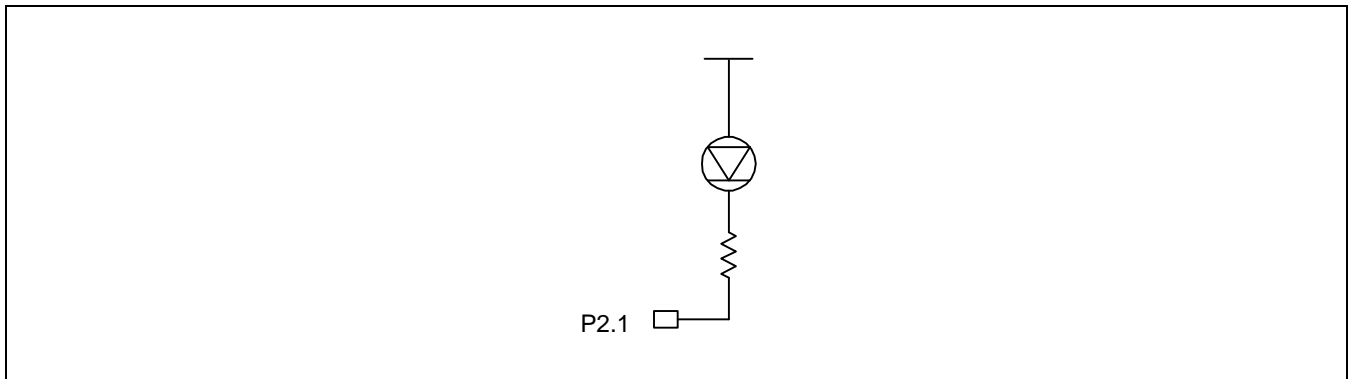

Figure 7-5. LED Drive Output Circuit

### Strobe Output Option

To active the optional strobe output function for TV and VCR remocn applications, the programmer must use the option selection strobe output pin (P2.6).

This pin has lower current drive capability than other pins and retain the pre-programmed status while in Halt mode. Be careful to turn on the option strobe output pin when a reset signal is generated. Because the reset sends all internal and external output pins to low level, the option strobe output pin should always be non-active state (H-Z). The pin should be active only when you are checking option status to reduce current consumption.

Table 7-4. Strobe Output Option

Pin usage	Key Output	LED Drive	Option Selection
P3.0-P3.3, P2.2-P2.5	00	X	X
P2.1	0	00	0
P2.6	0	0	00

**NOTE:** X = not allowed  
 0 = good  
 00 = better



Output Pin Circuit Type

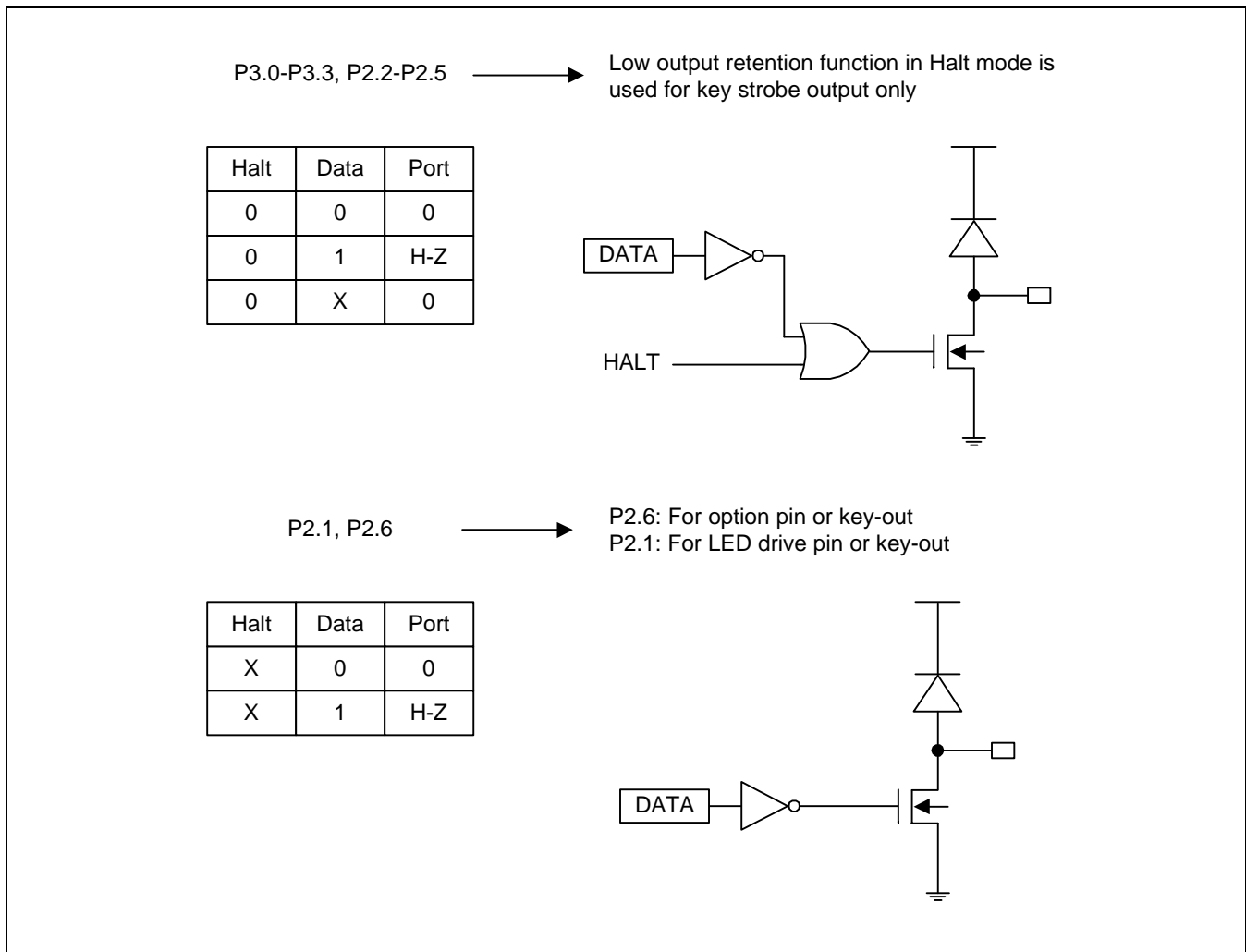

Figure 7-6. Output Pin Circuits

### Soft Ware Delay Routine

To obtain a constant time value, the S3C1840/C1850/C1860 use a software delay routine (there is not an internal timer interrupt). One instruction cycle is six oscillator clocks. Using a ceramic resonator with a constant frequency, you can calculate the time delay as follows:

$$t = 6/f_{xx} \times \text{Number of Instructions}$$

Where t: Elapsed time and f<sub>xx</sub>: System clock.

### Programming Tip

To program a 1-ms delay: 1 ms = 6/455 kHz x n, where f<sub>xx</sub> = 455 kHz  
Therefore, n = 75.8 = 76 instructions

```
DLY1MS  CLR      A
          ADDS    A,#0BH      ; Two instructions
DLY      MOV     H,#0        ; Dummy instruction
          MOV     H,#0        ; Dummy instruction
          MOV     H,#0        ; Dummy instruction
          MOV     H,#0        ; Dummy instruction
          DECS   A
          JP     DLY          ; DLY loop: 6 instructions
```

;2 + (ACC + 1) x instructions in loop = 2 + (11 + 1) x 6 = 74

```
          CLR     A
          CLR     A          ; Two instructions.
```

; Total number of instructions for DLY1MS is 76.

### NOTE

In order to lengthen the delay time, you can use an arithmetic instruction combination of L register and Accumulator. The L register causes the address lower pointer to access RAM space and the output port pointer to control the P2 (individual/serial output) port status.

- RAM manipulation instruction: RAM address pointer.
 

```
MOV     A,@HL      CPNE @HL,A
ADDS    A,@HL      SETB  @HL.b
```
- P2 output control instruction: P2 pointer.
 

```
SETB   P2.(L)     CLR   P2.(L)
```

## PROGRAMMING GUIDELINES

When programming S3C1840/C1850/C1860 microcontroller, please follow the guidelines presented in this subsection.

### PCB Artwork

For remote control applications, turning the I.R.LED on and off may cause variations in transmission current ranging from a few hundred  $\mu\text{A}$  to a few hundred mA. This current variation generates overshoot and undershoot noise on the power line, causing a system malfunction.

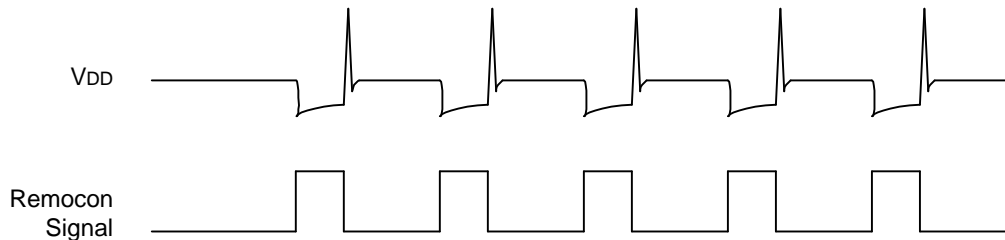

To reduce noise and to stabilize the chip's operation, we recommend that the application designer reduce overshooting of the I.R.LED drive current and design PCB for the remote controller as follows: (The noise level should be limited to around  $0.5 V_{P-P}$ , where  $V_{P-P}$  is the peak-to-peak voltage)

- Oscillation circuit should be located as near as possible to the chip.
- PCB pattern for  $V_{DD}/V_{SS}$  should be as wide and short as possible.
- I.R.LED drive TR and I.R.LED should be located as far as possible from the chip.
- Power supply battery and power capacitor should be located as near as possible to the chip.
- The ground pattern of the TEST pin (Ground of I.R.LED drive TR) and  $V_{SS}$  pin should be separated and connected directly with the battery terminal.
- The ceramic capacitor (0.1 $\mu\text{F}$  or 0.01 $\mu\text{F}$ ) and power capacitor(over 47 $\mu\text{F}$ ) is recommended to use noise filter.

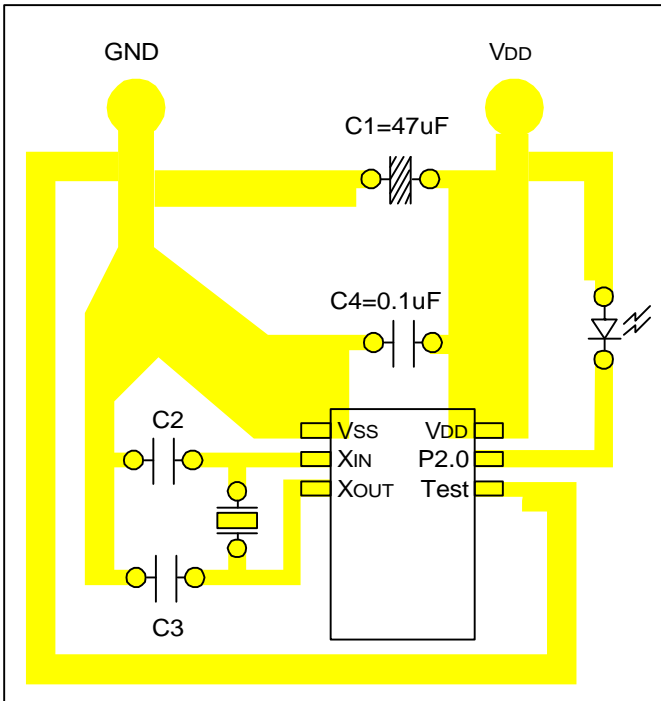

Recommended Artwork for S3C1850/C1860

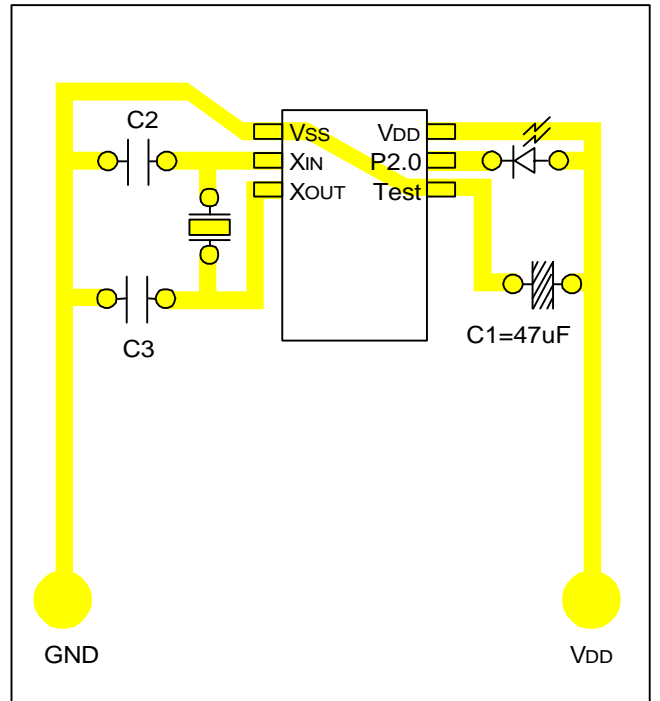

Unacceptable Artwork for S3C1850/C1860

## SMDS

When a breakpoint or single-step instruction is executed in area of PAGE and JP or CALL instruction, the JP or CALL may jump to the wrong address. We therefore recommend using a JPL or CALL instruction (instead of PAGE and JP or PAGE and CALL) to avoid this problems. Note that JP and CALL are 2-byte instructions.

### Programming Guidelines for Reset Subroutine

1. We recommend that you initialize a H register to either "0" or "4"
2. Do not write the instructions CALLL (PAGE + CALL) or JPL (PAGE + JP) to the reset address 0F00H. In other words, do not use a PAGE instruction at 0F00H.
3. Turn off the LED output pin.
4. To reduce current consumption, do not set the option output pin to active state.
5. Pre-set the remocon carrier frequency (to fxx/12, fxx/8, and so on) before remocon signal transmission.
6. Because the program is initialized by an auto-reset or Halt mode release, even in normal operating state, do not pre-set all RAM data. If necessary, pre-set only the RAM area you need.
7. Be careful to control output pin status because some pins are automatically changed to active state.
8. To enter Halt mode, the internal port, IP2.12, should be set to high level and all of the input pins should be set to normal state.
9. To release Halt mode, an active level signal is supplied to input pins. If pulse width is less than 9 ms at fxx = 455 kHz, nothing happens and program re-enters Halt mode. That is, the external circuit should maintain the input pulse over a 9-ms interval in order to release Halt mode. After Halt mode is released, the hardware is reset. The hardware reset sends all internal and external output pins low (except P2.0 in S3C1850/C1860) and clears the stack to zero. However, H,L and A registers retain their previous status.
10. If a rising edge is not generated at IP2.0, reset signal occurs every 288 ms at fxx = 455 kHz. To prevent an auto-reset, IP2.0 should be forced low and then high at regular intervals (within 288 ms at fxx = 455 kHz).

S3C1840 Application Circuit Example

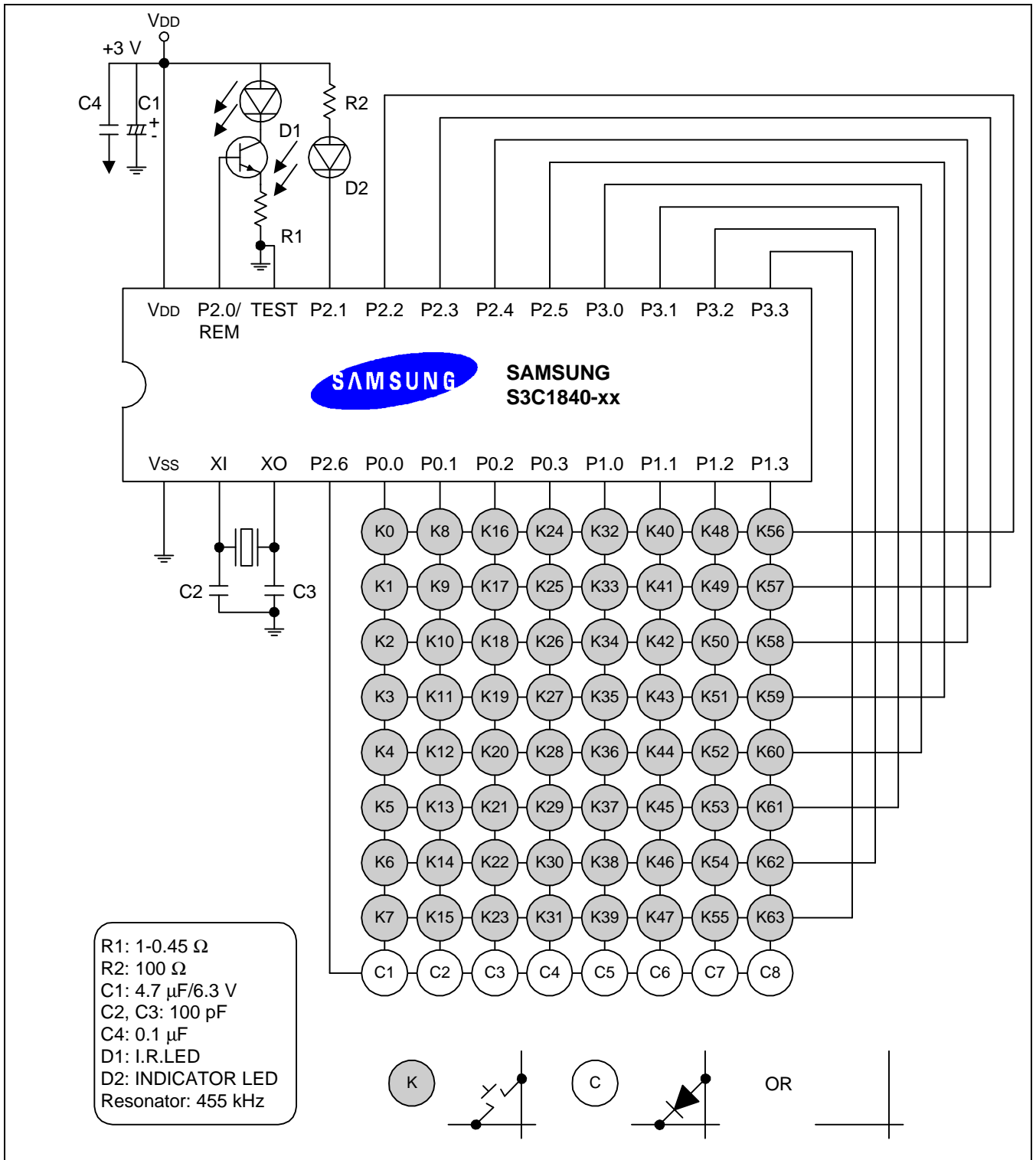

Figure 7-7. S3C1840 Application Circuit Example

S3C1850 Application Circuit Example

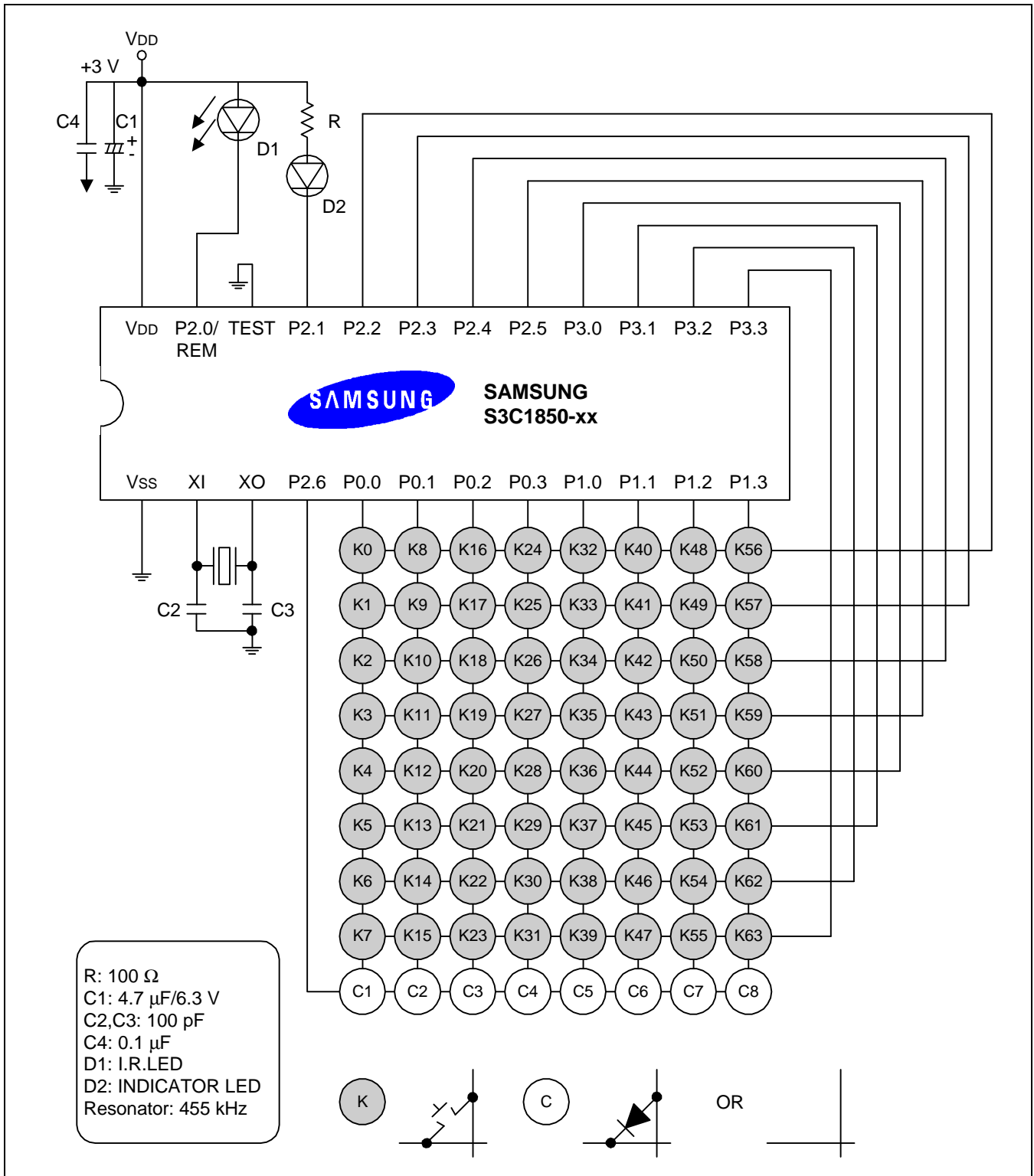

Figure 7-8. S3C1850 Application Circuit Example

S3C1860 Application Circuit Example

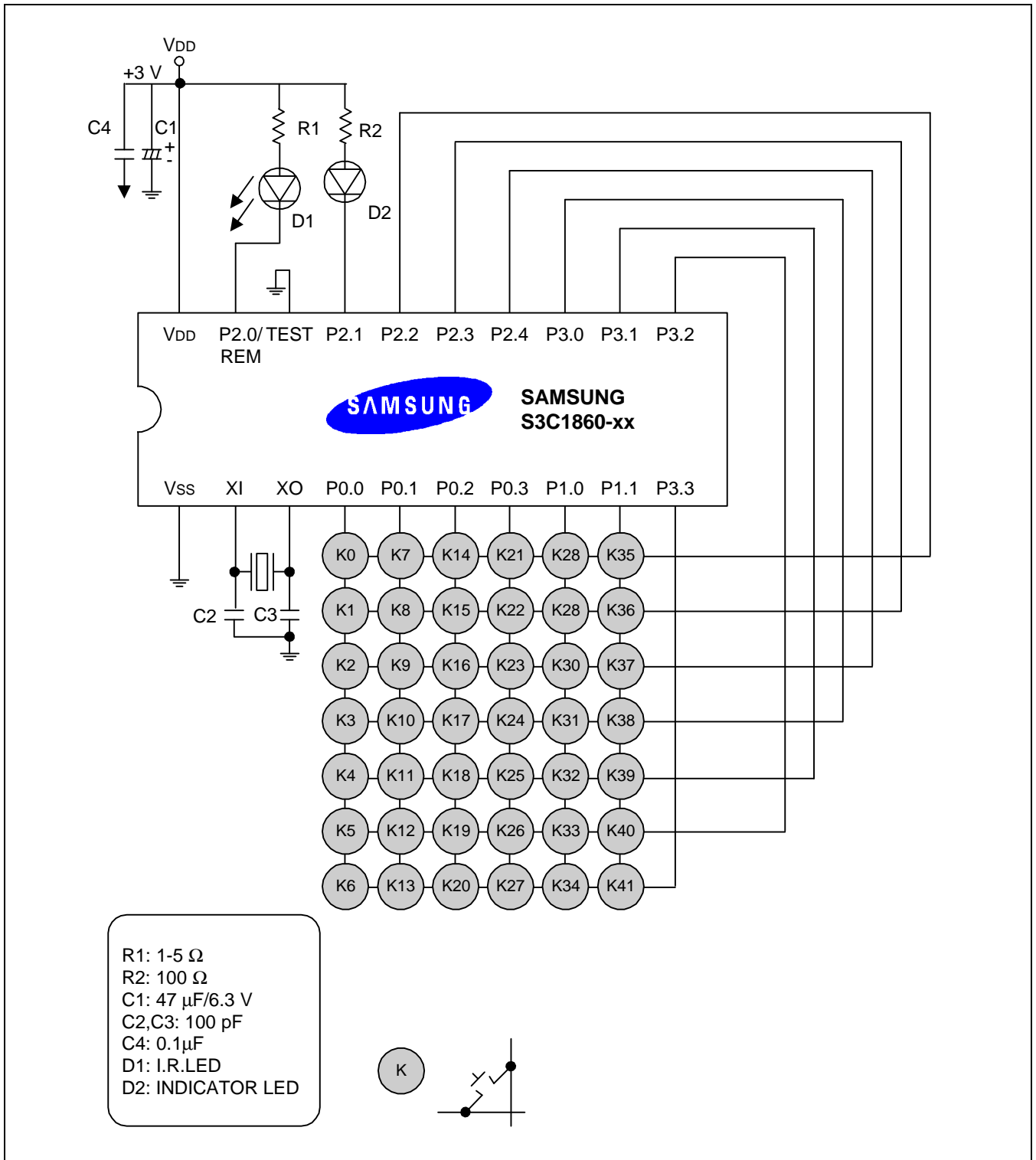

Figure 7-9. S3C1860 Application Circuit Example



Program Flowchart (This program is only apply to S3C1840)

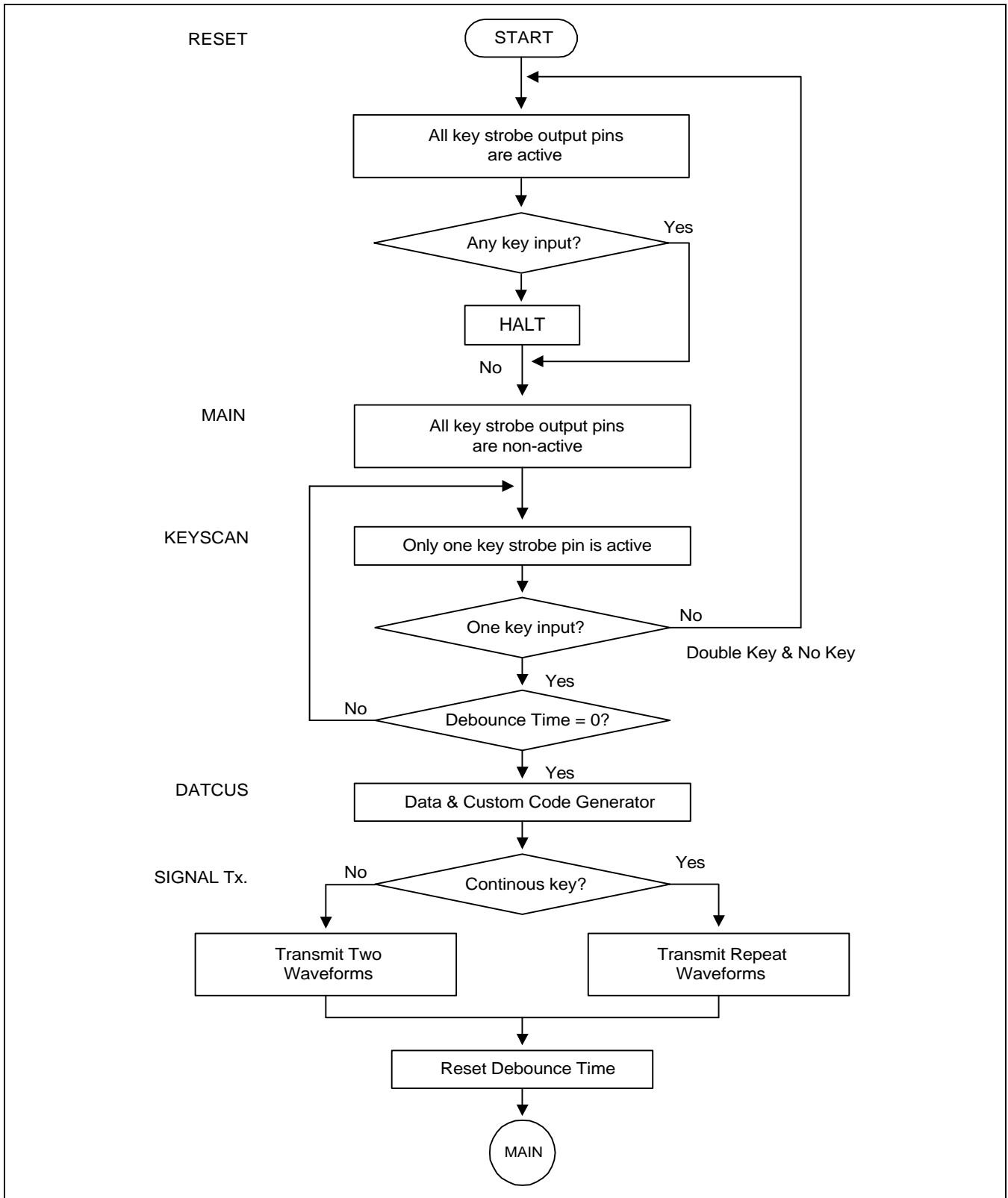

Figure 7-10. Program Flowchart 1

## S3C1840/C1850 KEYSKAN FUNCTION

### Description

This program has an 8 x 9 key matrix, which consists of input P0 and P1 and output P2 and P3. Because pull-up resistors are connected, the normal state for all input pins is high level. The operating method for the keyscan function is as follows:

- All output pins remain active state (= low).
- If key is pressed, set all output pins to non-active state and rotate the pins to set only a pin to active state during debounce time.
- If key is pressed more than one or if no key is pressed, go to reset label.
- If a new key is pressed, reset debounce time, continuous flag, and key-in flag.

### RAM Assignment

H register selects #0

HL →	00H	01H			05H				09H	
	O_INP0	N_INP0	O_INP1	N_INP1	O_OUTP	N_OUTP	I_TWICE	DEBOCNT	CONKEY	KFLG

O_INP0:	The old value of P0
N_INP0:	The new value of P0
O_INP1:	The old value of P1
N_INP1:	The new value of P1
O_OUTP:	The old value of output port
N_OUTP:	The new value of output port
I_TWICE:	Double number increment
DEBOCNT:	Debounce time
CONKEY:	Continuous key flag
KFLG:	key input flag

Program Flowchart (This program is only apply to S3C1840)

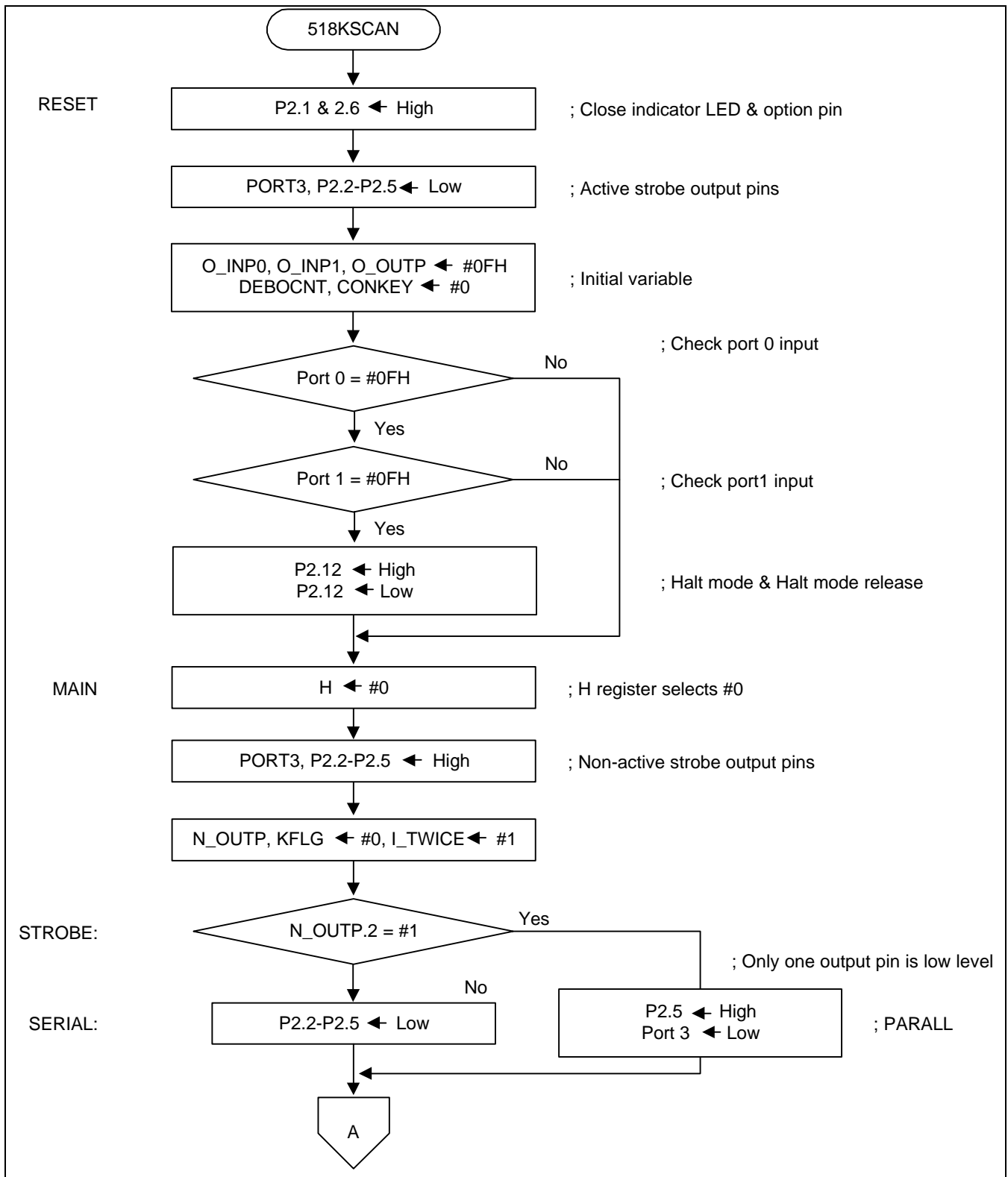

Figure 7-11. Program Flowchart 2

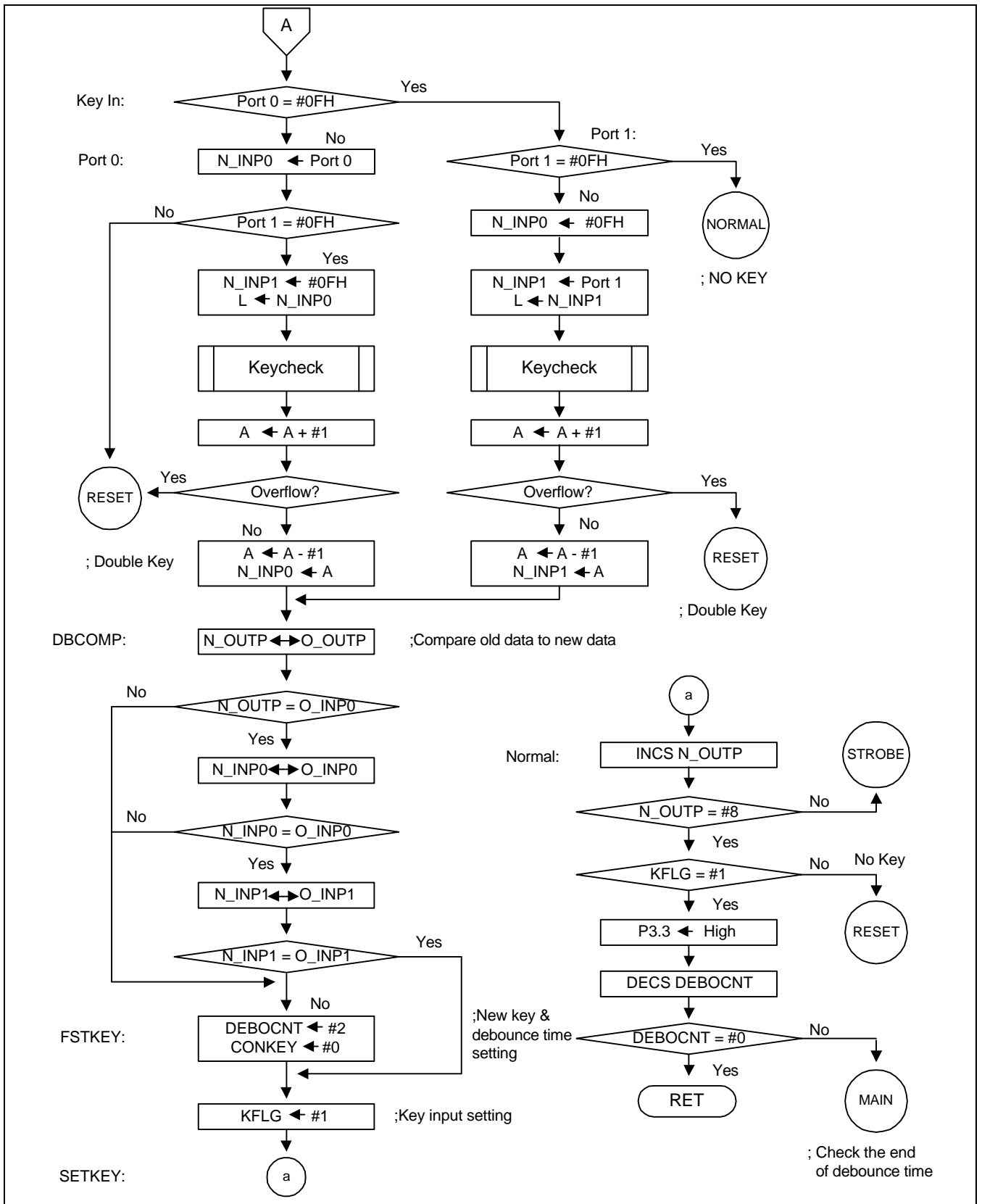

Figure 7-12. Program Flowchart 3



S3C1840/C1850 Keycheck Subroutine

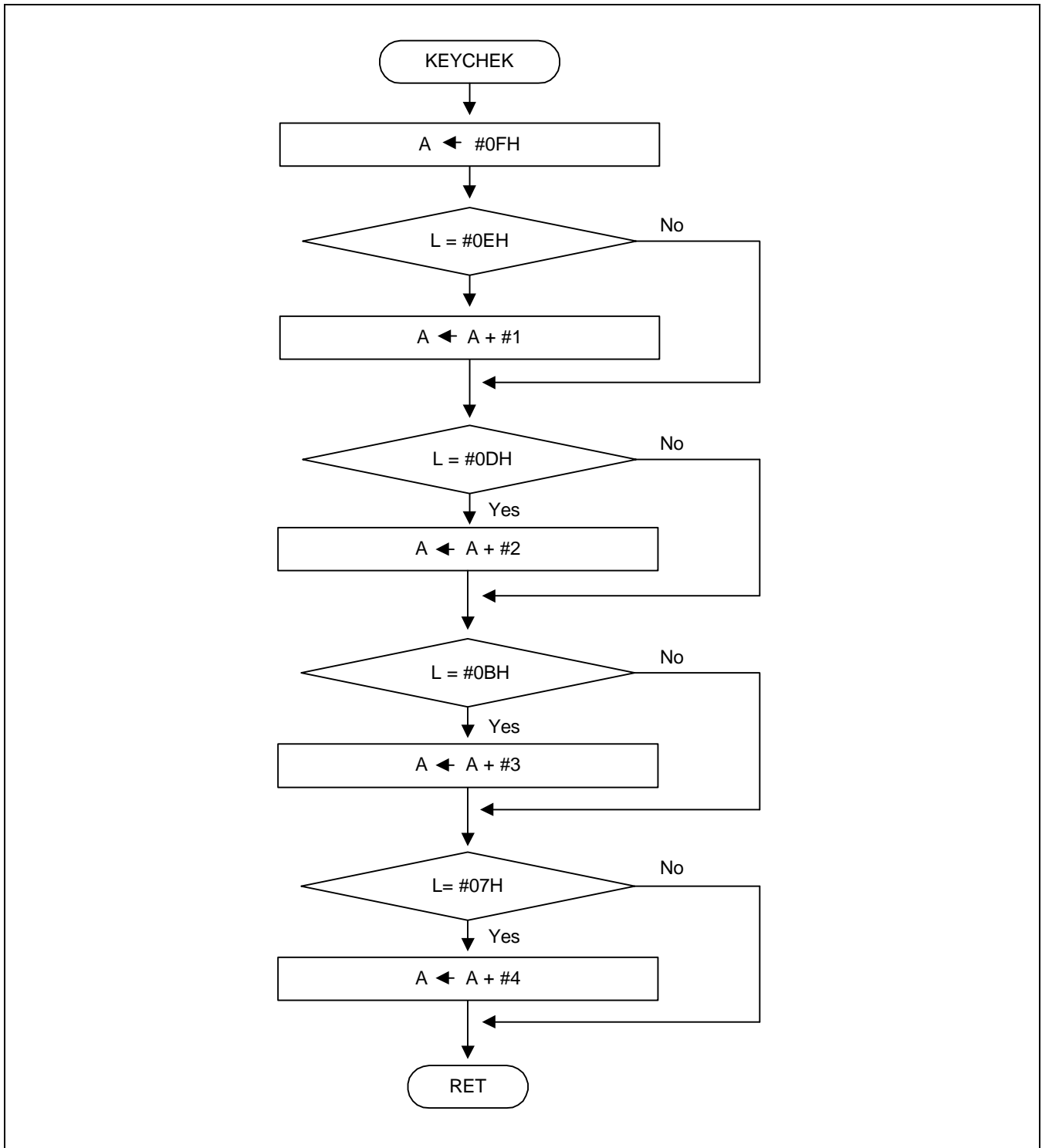

Figure 7-13. S3C1840/C1850 Keycheck Subroutine

```
*****
;
```

```
    ORG    0F00H
```

```
*****
;
```

```
; If reset occurs, PA register is immediately initialized to #0FH
```

```
RESET    MOV     L,#1           ; close indicator LED
         SETB   P2.(L)         ;
         MOV     L,#6           ; non-select P2.6
         SETB   P2.(L)         ;

PRTCLR   CLR     A             ;
         OUT    P3,@SL + A     ; low all the output ports
         MOV     L,#5           ; (except P2.0, P2.1, P2.6)
         CLRB   P2.(L)         ;
         DECS   L              ;
         CPNE   L,#1           ;
         JP     -.3            ;
```

```
;;; initial all of the variables -----
```

```
;;; → input ports are connected with pull-up resistor
```

```
;;; → Therefore, normal state → high
```

```
    MOV     H,#0             ; H register selects file #0
    MOV     L,#O_INP0        ; port0 is #0fh
    MOV     @HL+,#0FH
    MOV     L, #O_INP1       ; port1 is #0fh
    MOV     @HL +,#0FH
    MOV     L, #O_OUTP       ; the strobe out is #0fh
    MOV     @HL+,#0FH
    MOV     L,#DEBOCNT       ; debounce count is #0
    MOV     @HL+,#0
    MOV     L,#CONKEY        ; continuous key is #0
    MOV     @HL+,#0
```

```
;;; check each input port (=key input) -----
```

```
    MOV     L,#0DH           ; check port0
    CLRB   P2.(L)           ;
    IN     A,P0              ;
    MOV     L,A              ;
    CPNE   L,#0FH           ;
    JP     DELAYP0          ;
    MOV     L,#0DH           ; check port1
    SETB   P2.(L)           ;
    IN     A,P0              ;
    MOV     L,A              ;
    CPNE   L,#0FH           ;
    JP     J_MAIN           ;
```

```
;;; halt mode, after halt mode release, go to reset -----
```

```
    MOV     L,#0CH
    SETB   P2.(L)           ; halt mode
    CLRB   P2.(L)           ; halt mode release
    JP     RESET
```

```
PRTSET  CLR      A                ;
        ADDS    A,#0FH           ; high all the output ports
        OUT     P3,@SL+A        ; (P3, P2.2-P2.5)
        MOV     L,#5            ;
        SETB   P2.(L)          ;
        DECS   L                ;
        CPNE   L,#1            ; If P2.0 is high, data Tx.
        JP     .- 3            ; and auto reset counter clear
        RET
```

```
DELAYP0 MOV     H #0            ; for the match of delay time
        MOV     H #0
        MOV     H #0
        MOV     H #0
        MOV     H #0
        MOV     H #0
```

```
J_MAIN  JPL     MAIN
```

```
;
;
;
;*****
;
```

```
ORG     0000H
JPL     RESET
```

```
;*****
;
```

```
MAIN    MOV     H,#0            ; H regisster selects file #0
        ; useful when continous pulse Tx.
        ;
        CALLL  PRTSET          ; high all the output ports
```

;;; initial useful variable in main routine -----

```
MOV     L,#N_OUTP            ; N_OUTP ← #0
MOV     @HL+,#0
MOV     L,#1_TWICE          ; I_TWICE (double increment) ← #1
MOV     @HL+,#1
MOV     L,#KFLG             ; KFLG ← #0 (input key flag)
MOV     @HL+,#0
```

;; select output pin by one and one -----

```
STROBE  MOV     L,#N_OUTP
        CPBT   @HL.2          ; If N_OUTP.2 is set, go to parall (parallel port)
        JP     PARALL         ; otherwise, go to serial (serial port)
```

```
SERIAL  MOV     L,@HL
        INCS   L
        SETB   P2.(L)        ; low P2.2-P2.5
        INCS   L
        CLRB   P2.(L)
        JPL    KEYIN
```

```
PARALL  MOV     L,#5
        SETB   P2.(L)
```



```

*****
;;
;; A ← #0h
;; A ← A-1_TWICE
;; output P3
;; I_TWICE ← I_TWICE + I_TWICE
*****
;;
        CLR        A                ; A ← #0FH
        ADDS       A, #0FH          ;
        MOV        L, #1_TWICE     ;
        XCH        @HL,A           ; A ← A-I_TWICE
        SUBS       A,@HL           ;
        OUT        P3,@SL+A        ; low port3
        SUBS       A,@HL           ;
        MOV        @HL,A           ; recover I_TWICE
        ADDS       A,@HL           ;
        MOVZ      @HL,A           ; I_TWICE ← I_TWICE + I_TWICE
        JPL        KEYIN
*****
;;
;; check double key at each port
;; if a key pressed, do adds instruction
;; otherwise, induce overflow occurrence
*****
KEYCHEK CLR        A                ; A ← #0fh
        ADDS       A,#0FH          ;
        CPNE      L,#0EH          ;
        JP         .+2             ;
        ADDS       A,#1           ; A ← #0
        CPNE      L,#0DH          ;
        JP         .+2             ;
        ADDS       A,#2           ; A ← #1
        CPNE      L,#0BH          ;
        JP         .+2             ;
        ADDS       A,#3           ; A ← #2
        CPNE      L,#7            ;
        JP         .+2             ;
        ADDS       A,#4           ; A ← #3
        RET
;
;
;
*****
;
        ORG        0100H
        JPL        RESET
*****
KEYIN   MOV        L,#0DH
        CLR        P2.(L)

;;; select port0 -----
        IN         A, P0
        MOV        L,A
        CPNE      L,#0FH          ; is key pressed in port0 ?
        JP        PORT0
        JP        PORT1

```



```

PORT0    MOV      L,#N_INP0      ; setting at N_INP0
          MOV      @HL,A         ;
          MOV      L,#ODH        ;
          SETB    P2.(L)         ;
          IN      A,P0           ;
          MOV      L,A           ;
          CPNE   L,#0FH         ;
          JP      DBKEY          ; If also port1 input a key,
                                   ; it is double key
          MOV      L,#N_INP1     ; Only N_INP0 input
          MOV      @HL+,#0FH     ; but N_INP1 is set to #0fh
          MOV      L,#N_INP0     ;
          MOV      L,@HL         ;
          CALLL   KEYCHEK        ;
          ADDS   A,#1            ;
          JP      DBKEY          ; if overflow occurs, it is double key
          DECS   A              ; because input value ranges
          MOV      L,#N_INP0     ; from #0 to #3
          MOVZ   @HL,A          ; N_INP0 ← A
          JPL    DBCOMP
    
```

;;; select port1 -----

```

PORT1    MOV      L,#0DH        ;
          SETB    P2.(L)         ;
          IN      A,P0           ;
          MOV      L,A           ;
          CPNE   L,#0FH         ; is key pressed in port 1?
          JP      .+3            ;
          JPL    NORMAL         ; no key, go to NORMAL
          MOV      L,#N_INP0     ; setting N_INP0 to #0fh
          MOV      @HL+,#0FH     ; Only N_INP1 input
          MOV      L,#N_INP1     ;
          MOV      @HL,A         ;
          MOV      L,A           ; L ← N_INP1
          CALLL   KEYCHEK        ;
          ADDS   A,#1            ; if overflow occurs, go to double key
          JP      DBKEY          ;
          DECS   A              ; because input value ranges from
                                   ; #0 to #3
          MOV      L,#N_INP1     ; N_INP1 ← A
          MOVZ   @HL,A
          JPL    DBCOMP
    
```

;;; if double key occurs, go to reset -----

```

DBKEY    JPL      RESET
;
;
;
    
```

. \*\*\*\*\*  
;

```

    ORG      0200H
    JPL      RESET

```

. \*\*\*\*\*  
;

;;; compare for the recognition of a new key-----

```

DBCOMP  MOV      H,#N_OUTP      ; compare N_OUTP to   O_OUTP
        MOV      A,@HL
        MOV      L,#O_OUTP
        XCH      @HL,A
        CPNE     @HL,A
        JP       FSTKEY
        MOV      L,#N_INP0      ; compare N_INP0 to  O_INP0
        MOV      A,@HL
        MOV      L,#O_INP0
        XCH      @HL,A
        CPNE     @HL,A
        JP       FSTDLY
        MOV      L,#N_INP1      ; compare N_INP1 to  O_INP1
        MOV      A,@HL
        MOV      L,#O_INP1
        XCH      @HL,A
        CPNE     @HL,A
        JP       FSTKEY
        JP       SETKEY

```

```

FSTDLY  MOV      H,#0           ; for match of delay time
        MOV      H,#0
        MOV      H,#0
        MOV      H,#0
        MOV      H,#0

```

;;; when new key input -----

```

FSTKEY  MOV      L,#DEBOCNT     ; DEBOCNT ← #2
        MOV      @HL+,#2
        MOV      L,#CONKEY     ; CONKEY ← #0
        MOV      @HL+,#0
SETKEY  MOV      L,#KFLG       ; KFLG ← #1
        MOV      @HL+,#1

```

```
. *****
;
;;; increase N_OUTP
;;; check N_OUTP is equal to #8
;;; check no key (= DEBOCNT)
. *****
;
```

```
NORMAL    MOV      L,#N_OUTP      ; increase N_OUTP
          INCS    A,@HL
          MOVZ    @HL,A
          ADDS   A,#8          ; A ← #8
          CPNE   @HL,A        ; compare N_OUTP to A
          JP     J_STRO       ; go to stroble label
          MOV    L,#KFLG      ;
          CPBT   @HL.0        ; check key flag
          JP     ONKEY
          JPL    RESET        ; no key

ONKEY     CLR     A
          ADDS   A,#0FH
          OUT    P3,@SL + A   ; set port3 to '1'
          MOV    L,#DEBOCNT   ; decrease DEBOCNT
          DECS  A,@HL
          XCH   @HL,A
          CPNZ  @HL          ; compare DEBOCNT TO #0
          JP    J1_MAIN
          JPL   KEYSKAN

J1_MAIN   JPL    MAIN
J_STRO    JPL    STROBE
```

**S3C1840/C1850 CODE GENERATION**

**Description**

This program generates data code and custom code. The custom code is determined according to diodes between input ports and output pin (P2.6). The data code is as follows:

RAM ← DAT0 (D0-D3), DAT1 (D4-D7)

	D0	D1	D2	D3	D4	D5	D6	D7
KEY0	0	0	0	0	0	0	0	0
KEY1	1	0	0	0	0	0	0	0
⋮	⋮							
KEY31	1	1	1	1	1	0	0	0
KEY32	0	0	0	0	0	0	1	0
KEY33	1	0	0	0	0	0	1	0
⋮	⋮							
KEY63	1	1	1	1	1	0	1	0

RAM ← DAT0 (D0-D3), DAT1\_0 (D4-D7)

	D0	D1	D2	D3	D4	D5	D6	D7
KEY0	0	0	0	0	0	0	0	0
KEY1	1	0	0	0	0	0	0	0
⋮	⋮							
KEY31	1	1	1	1	1	0	0	0
KEY32	0	0	0	0	0	1	0	0
KEY33	1	0	0	0	0	1	0	0
⋮	⋮							
KEY63	1	1	1	1	1	1	0	0

**RAM Assignment**

H register selects #4

HL →	40H	41H			45H				49H	
	CUS0	CUS1	CUS2	CUS3	DAT0	DAT1	DAT2	DAT3	DAT1_0	DAT3_0

- CUS0; Custom code (c0-c3)
- CUS1; Custom code (c4-c7)
- CUS2; The complement of CUS0
- CUS3; The complement of CUS1
- DAT0; Data code (d0-d3]
- DAT1; Data code (d4-d7)
- : → 32 key: 00000010, 63 key: 1111010
- DAT2; The complement of DAT0
- DAT3; The complement of DAT1
- DAT1\_0 Data code (d4-d7)
- : → 32 key: 00000100, 63 key: 1111100
- DAT3\_0 The complement of DAT1\_0

Program Flowchart

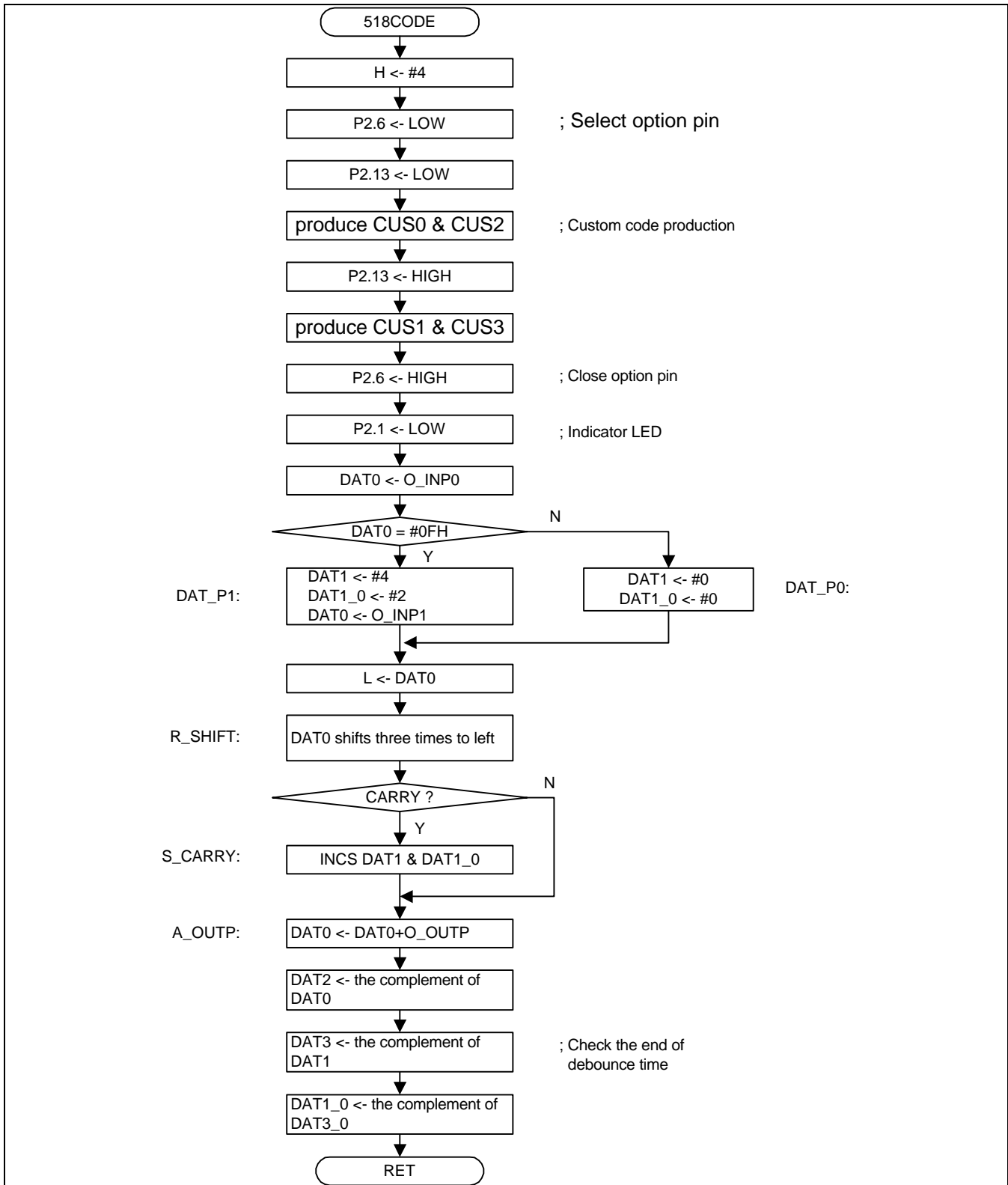

Figure 7-14. Program Flowchart 4

```
*****
;
```

```
    ORG      0300H
    JPL      RESET
```

```
*****
;
```

```
;;; select only a key -----
```

```
KEYSCAN  MOV      H,#4
```

```
;;; product custom code -----
```

```
    MOV      L,#6                ; P2.6 ← low
    CLRB     P2.(L)              ; check custom code
    MOV      L,#0DH              ;
    CLRB     P2.(L)              ;
    IN       A,P0                ;
    MOV      L,#CUS2             ; CUS2 is the complement of CUS0
    MOV      @HL,A               ;
    NOTI     A                   ;
    DECS     A                   ;
    MOV      L,#CUS0             ;
    MOV      @HL,A               ;
    MOV      L,#0DH              ;
    SETB     P2.(L)              ; CUS3 is the complement of CUS1
    IN       A,P0                ;
    MOV      L,#CUS3             ;
    MOV      @HL,A               ;
    ADDS     A,@HL               ;
    NOTI     A                   ;
    DECS     A                   ;
    MOV      L,#CUS1             ;
    MOVZ     @HL,A               ;
    MOV      L,#6                ; high P2.6
    SETB     P2.(L)              ;
    MOV      L,#1                ; the indicator LED of a key input
    CLRB     P2.(L)
```

```
;;; product data code -----
```

```
    MOV      H,#0
    MOV      L,#O_INP0           ; DAT0 ← O_INP0
    MOV      A,@HL
    MOV      H,#4
    MOV      L,#DAT0
    MOVZ     @HL,A
    ADDS     A,#0FH              ; A ← #0fh
    CPNE     @HL,A               ; does input key exist in port0?
    JP       DAT_P0
```

```

DAT_P1  MOV     L,#DAT1           ; input key exists in port1
        MOV     @HL+,#04H        ; DAT1 ← DAT1 + #4
        MOV     L,#DAT1_0
        MOV     @HL+,#02H        ; DAT1_0 ← DAT1_0 + #2
        MOV     H,#0             ; DAT0 ← O_INP1
        MOV     L,#O_INP1
        MOV     A,@HL
        MOV     H,#4
        MOV     L,#DAT0
        MOVZ    @HL,A
        JPL     R_SHIFT
DAT_P0  MOV     L,#DAT1           ; clear DAT1 & DAT1_0
        MOV     @HL+,#0
        MOV     L,#DAT1_0
        MOV     @HL+,#0
        MOV     L,#DAT0
        MOV     H,#4             ; delay time
        MOV     H,#4
        MOV     H,#4
        MOV     H,#4
        MOV     H,#4
        JPL     R_SHIFT
;
;
;
;*****
;
        ORG     0400H
        JPL     RESET
;*****
;
R_SHIFT MOV     A,@HL           ; DAT0 shifts three times to the left
        ADDS    A,@HL
        MOV     @HL,A
        ADDS    A,@HL
        MOV     @HL,A
        ADDS    A,@HL
        JP      S_CARRY
        JP      N_CARRY

S_CARRY MOV     L,#DAT1         ;if carry occurs, increase DAT1 & DAT1_0
        XCH     @HL,A
        INCS    A
        XCH     @HL,A
        MOV     L,#DAT1_0
        XCH     @HL,A
        INCS    A
        XCH     @HL,A
        JP      A_OUTP
    
```

```

N_CARRY  MOV      H,#0           ; if carry doesn't occur, delay time
          MOV      H,#0           ;
          MOV      H,#0           ;
          MOV      H,#0           ;
          MOV      H,#0           ;
          MOV      H,#0           ;
          MOV      H,#0           ;
          MOV      H,#0           ;

A_OUTP   MOV      H,#0
          MOV      L,#O_OUTP      ; DAT0 ← DAT0 + O_OUTP
          ADDS     A,@HL          ;
          MOV      H,#4           ;
          MOV      L,#DAT0
          MOV      @HL,A         ;
          NOTI     A
          DECS     A             ; DAT2 ← complement of DAT0
          MOV      L,#DAT2
          MOVz     @HL,A
          MOV      L,#DAT1
          MOV      A,@HL
          NOTI     A             ; DAT3 ← complement of DAT1
          DECS     A
          MOV      L,#DAT3
          MOVz     @HL,A
          MOV      L,#DAT1_0
          MOV      A,@HL
          NOTI     A
          DECS     A
          MOV      L,#DAT3_0      ; DAT3_0 ← complement of DAT 1_0
          MOV      @HL,A
          JPL      TX

```



**S3C1840/C1850 SIGNAL TRANSMISSION**

**Description**

This program is for signal transmissions in SAMSUNG standard format. If one key is pressed, two frames are transmitted consecutively. The repeat pulse is transmitted until key-off. The frame interval is 60 ms. Each frame consists of leader code, custom code, and data code:

- Leader code (high level for 4.5 ms and low level for 4.5 ms)
- 12-bit custom code
- 8-bit data code

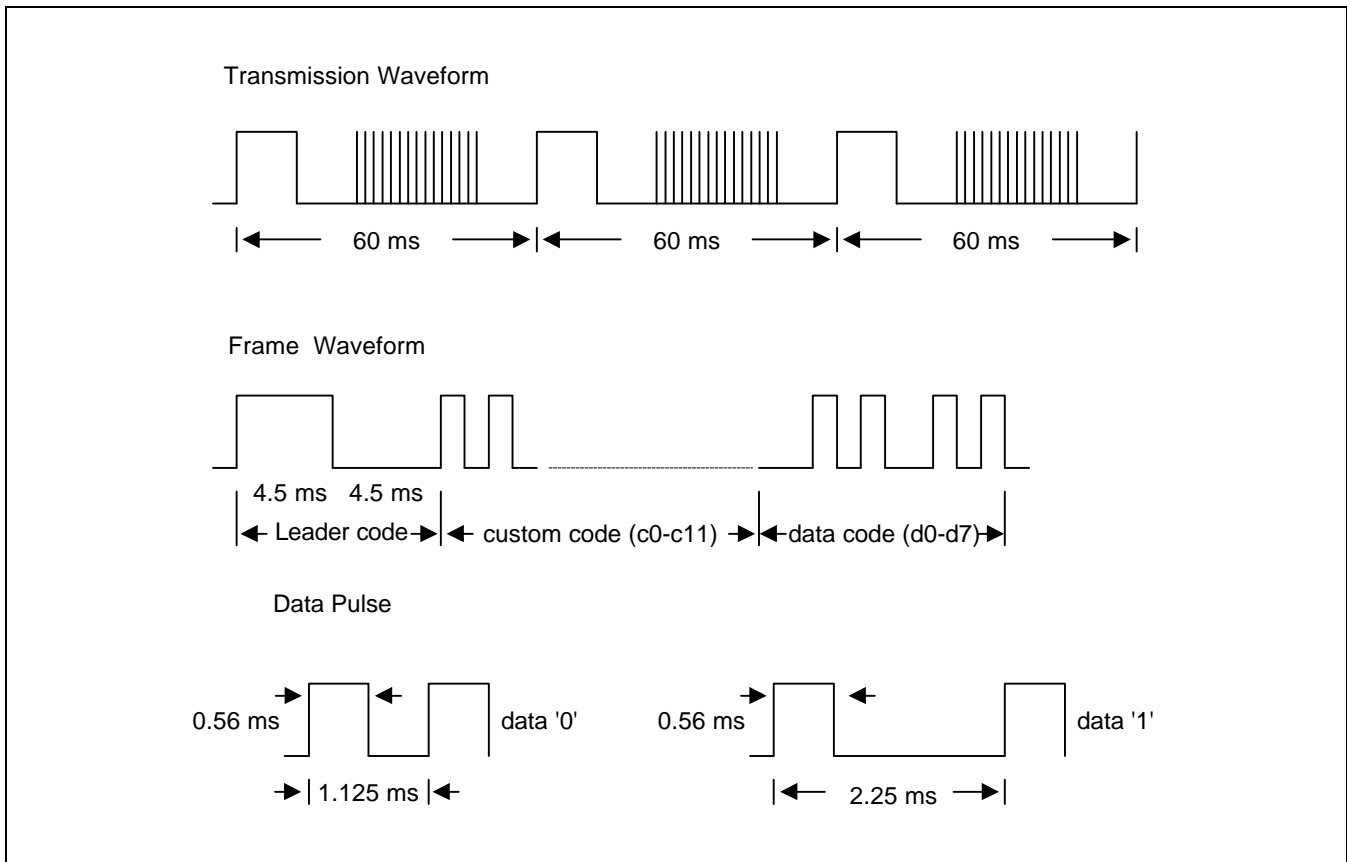

**Figure 7-15. Transmission Waveforms**

**RAM Assignment**

This part is the same as for keyscan and code generation.

S3C1840 Program Flowchart (This program is only apply to S3C1840)

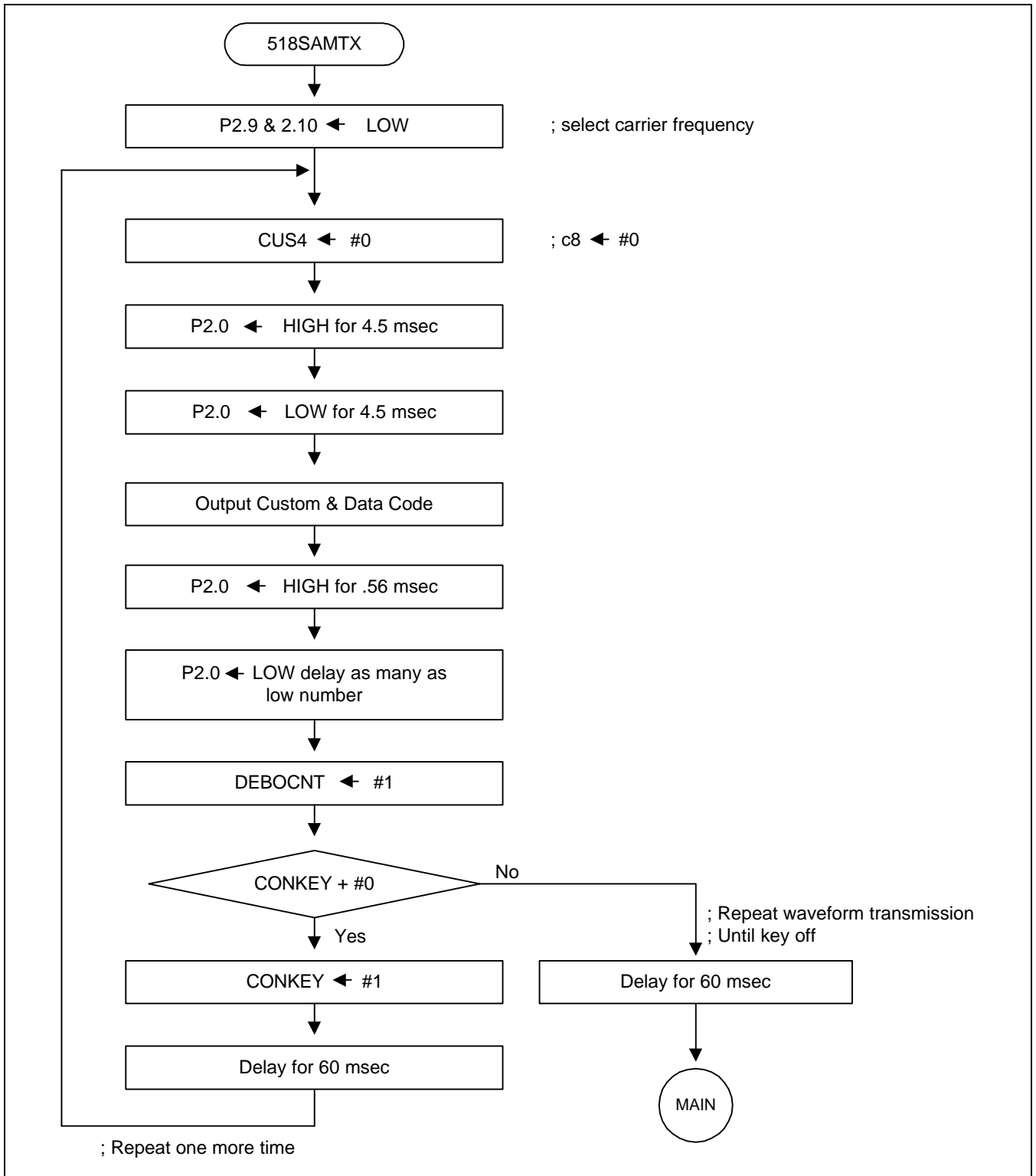

Figure 7-16. S3C1840 Program Flowchart 5

```

*****
,
        ORG      0500H
        JPL      RESET
*****
,
TX      MOV      L,#9           ; select carrier frequency
        CLRB     P2.(L)        ; 37.9 kHz, 1/3 duty
        MOV      L,#0AH        ; clear P2.9 & 2.10
        CLRB     P2.(L)

SIGOUT  MOV      L,#CUS4        ; custom code (c8-c11) ← #0
        MOB      @HL+,#0        ; if device is KS51910, c8 ← #1
;;; output head pulse -----
        MOV      L,#0           ; high for delay time 4.5 msec
        SETB     P2.(L)
        CALLL    D4_5
        MOV      L,#0
        CLRB     P2.(L)        ; low for delay time 4.5 msec
        CALLL    D4_5D

;;; output custom code (c0-c11) & data code (d0-d7)
        MOV      L,#CUS0        ; custom code (c0-c3)
        CALLL    DATGEN
        MOV      L,#CUS1        ; custom code (c4-c7)
        CALLL    DATGEN
        MOV      L,#CUS4        ; custom code (c8-c11)
        CALLL    DATGEN
        MOV      L,#DAT0        ; data code (d0-d3)
        CALLL    DATGEN
        MOV      L,#DAT1_0      ; data code (d4-d7)
        CALLL    DATGEN
        MOV      L,#1
        DECS     L
        JP       .-1
        MOV      L,#0           ; EOB (end of bit)
        SETB     P2.(L)        ; high for .56msec
        CALLL    D_560F
        MOV      L,#0
        CLRB     P2.(L)
        JPL      LOWCHEK
    
```

```

*****
;
        ORG      0600H
        JPL      RESET
*****
;
;;; check low code of custom code & data code -----
LOWCHEK MOV      L,#CUS0          ; custom code (c0-c3)
        CALL    LCHEK
        MOV     L,#CUS1          ; custom code (c4-c7)
        CALL    LCHEK
        MOV     L,#CUS4          ; custom code (c8-c11)
        CALL    LCHEK
        MOV     L,#DAT0          ; data code (d0-d3)
        CALL    LCHEK
        MOV     L,#DAT1_01       ; the maximum value of upper bit is #3
        MOV     A,L              ; data code (d4-d7)
        CALL    LCHEK_1         ; check from the second bit

;== notice =====
; If value of DAT1_0 is greater than #3, programmer must change instruction
; CALLLCHEK_1 to other instruction such as CALLCHECK_2 or CALL
; LCHEK. And you must check the fram interval (= 60 msec)
;=====

;;; re-setting debounce count to #1-----
SETDBT  MOV      H,#0
        MOV     L,#DEBOCNT      ; DEBOCNT ← #1
        MOV     @HL+,#1

;-----
;;; If conkey flag isn't '0', transmit repeat pulse
;;; otherwise, after setting, transmit again (two frames)
;-----

CONCHEK MOV      H,#0
        MOV     L,#CONKEY       ; CONKEY == #0?
        CPNZ   @HL              ; If CONKEY is #0, CONKEY ← #1
        JP     LJ_MAIN          ; transmit frame again
        MOV     @HL+,#1
        CALLL  D4_5D            ; time is 60 msec per frame
        CALLL  D2_25
        CALLL  D1_125
        MOV     L,#0CH
        MOV     H,#4
        MOV     H,#4
        DECS   L
        JP     -.3
        JPL    SIGOUT

```

```

;;; output repeat pulse -----
LJ_MAIN  CALL    D1_125
         JPL     MAIN
;;; output delay time as many as low numbers -----

LCHEK    MOV     A,L
         CPBT   @HL,3           ; if @hl.3 is low, call d2_25d.
         JP     LCHEK_2
         CALLL  D2_25D
LCHEK_2  MOV     L,A
         CPBT   @HL.2           ; if @hl.2 is low, call d2_25d.
         JP     LCHEK_1
         CALLL  D2_25D
LCHEK_1  MOV     L,A
         CPBT   @HL.1           ; if @hl.1 is low, call d2_25d.
         JP     LCHEK_0
         CALLL  D2_25D
LCHEK_0  MOV     L,A
         CPBT   @HL.0           ; if @hl. 0 is low, call d2_25d.
         JP     LCHEK_R
         CALLL  D2_25D
LCHEK_R  RET

;
;
;
;
;
;
;
*****
;
         ORG    0700H
         JPL    RESET
*****
;;; custom code & data code generation -----
DATGEN   MOV     A,L
         CALL   D_560           ; high for .56 msec
         CPBT   @HL.0           ; if @hl.0 is high, low for 2.25 msec.
         CALL   D2_25           ; otherwise, low for 1.125 msec.
         CALL   D1_125
    
```

```

CALL      D_560          ; high for .56 msec
CPBT      @HL.1         ; if @hl.1 is high, low for 2.25 msec.
CALL      D2_25         ; otherwise, low for 1.125 msec.
CALL      D1_125
CALL      D_560          ; high for .56 msec
CPBT      @HL.2         ; if @hl.2 is high, low for 2.25 msec.
CALL      D2_25         ; otherwise, low for 1.125 msec.
CALL      D1_125
CALL      D_560          ; high for .56 msec
CPBT      @HL.3         ; if @hl.3 is high, low for 2.25 msec.
CALL      D2_25         ; otherwise, low for 1.125 msec.
CALL      D1_125D
RET

```

;;; delay time subroutine by programming -----

```

D_560     MOV      L,#0
          SETB     P2,(L)
;
          MOV      L,#0CH
          MOV      H,#4
          DECS     L
          JP       .-2
          MOV      H,#4
;
          MOV      L,#0
          CLRB     P2.(L)
          MOV      L,A
          RET
D4_5D     MOV      L,#02H          ; delay time 4.5 msec
          JP       .+2
D4_5      MOV      L,#06H
          DECS     L
          JP       -1
          MOV      L,#05H
          CLR      A
          ADDS     A,#0BH
          MOV      H,#4
D_A       DECS     A
          JP       .-2
          DECS     L
          JP       .-6

```

```

D2_25D    MOV    L,#0EH
          JP     .+2
D2_25     MOV    L,#0FH
          MOV    H,#4
          DECS  L
          JP     .-2
D1_125    MOV    L,#0AH
          JP     .+6
D1_125D   MOV    L,#08H
          JP     .+4
D_560F    MOV    L,#0BH           ; delay time .56 msec (for EOB)
          MOV    H,#4
          MOV    H,#4
          DECS  L
          JP     .-2
          RET

```

```

;
;

```

```

org      0800h
jpl     reset
org      0900h
jpl     reset
org      oaooh
jpl     reset
org      obooh
jpl     reset
org      ocooh
jpl     reset
org      odooh
jpl     reset
org      oeooh
jpl     reset

```

```

;
```

.\*\*\*\*\* The END of S3C1840 SAMSUNG FORMAT TX. \*\*\*\*\*