



# 3.3V CMOS 16-BIT BUFFER/DRIVER WITH 3-STATE OUTPUTS AND BUS-HOLD

**IDT74ALVCH16244**

## FEATURES:

- 0.5 MICRON CMOS Technology
- Typical  $t_{sk(o)}$  (Output Skew) < 250ps
- ESD > 2000V per MIL-STD-883, Method 3015; > 200V using machine model (C = 200pF, R = 0)
- $V_{CC} = 3.3V \pm 0.3V$ , Normal Range
- $V_{CC} = 2.7V$  to  $3.6V$ , Extended Range
- $V_{CC} = 2.5V \pm 0.2V$
- CMOS power levels (0.4 $\mu$  W typ. static)
- Rail-to-Rail output swing for increased noise margin
- Available in SSOP, TSSOP, and TVSOP packages

## DRIVE FEATURES:

- High Output Drivers:  $\pm 24mA$
- Suitable for heavy loads

## APPLICATIONS:

- 3.3V high speed systems
- 3.3V and lower voltage computing systems

## DESCRIPTION:

This 16-bit buffer/driver is built using advanced dual metal CMOS technology. The ALVCH16244 is designed specifically to improve the performance and density of 3-state memory address drivers, clock drivers, and bus-oriented receivers and transmitters. The device can be used as four 4-bit buffers, two 8-bit buffers, or one 16-bit buffer. It provides true outputs and symmetrical active-low output-enable ( $\overline{OE}$ ) inputs.

The ALVCH16244 has been designed with a  $\pm 24mA$  output driver. This driver is capable of driving a moderate to heavy load while maintaining speed performance.

The ALVCH16244 has "bus-hold" which retains the inputs' last state whenever the input bus goes to a high impedance. This prevents floating inputs and eliminates the need for pull-up/down resistors.

## FUNCTIONAL BLOCK DIAGRAM

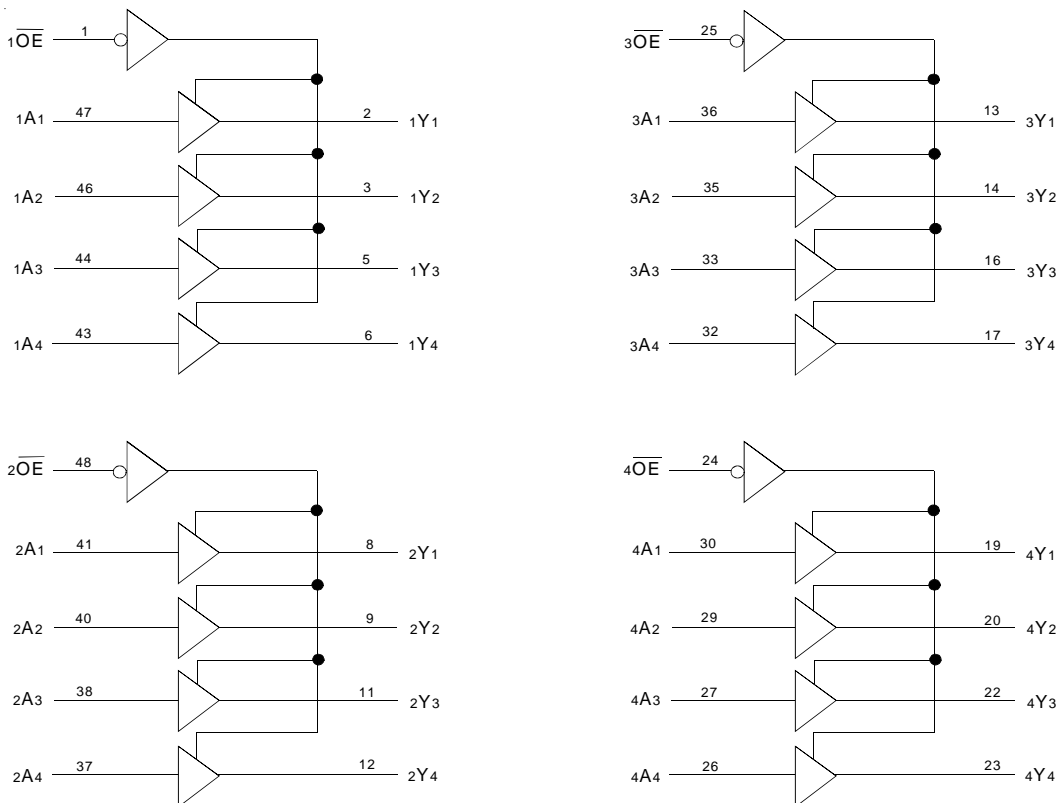

The IDT logo is a registered trademark of Integrated Device Technology, Inc.

INDUSTRIAL TEMPERATURE RANGE

MARCH 1999

## PIN CONFIGURATION

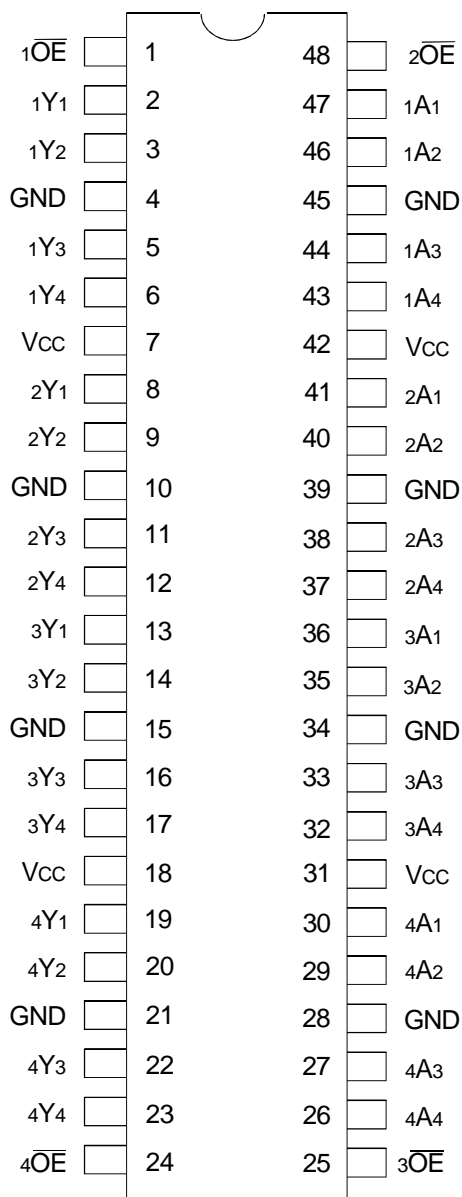

SSOP/ TSSOP/ TVSOP  
TOP VIEW

## ABSOLUTE MAXIMUM RATINGS<sup>(1)</sup>

| Symbol                             | Description   | Max             | Unit |
|------------------------------------|---|-----------------|------|
| VTERM <sup>(2)</sup>               | Terminal Voltage with Respect to GND                                    | -0.5 to +4.6    | V    |
| VTERM <sup>(3)</sup>               | Terminal Voltage with Respect to GND                                    | -0.5 to Vcc+0.5 | V    |
| TSTG                               | Storage Temperature   | -65 to +150     | °C   |
| IOUT                               | DC Output Current   | -50 to +50      | mA   |
| I <sub>IK</sub>                    | Continuous Clamp Current,<br>V <sub>I</sub> < 0 or V <sub>I</sub> > Vcc | ±50             | mA   |
| I <sub>OK</sub>                    | Continuous Clamp Current, V <sub>O</sub> < 0                            | -50             | mA   |
| I <sub>CC</sub><br>I <sub>SS</sub> | Continuous Current through each<br>Vcc or GND                           | ±100            | mA   |

### NOTES:

- Stresses greater than those listed under ABSOLUTE MAXIMUM RATINGS may cause permanent damage to the device. This is a stress rating only and functional operation of the device at these or any other conditions above those indicated in the operational sections of this specification is not implied. Exposure to absolute maximum rating conditions for extended periods may affect reliability.
- Vcc terminals.
- All terminals except Vcc.

## CAPACITANCE (T<sub>A</sub> = +25°C, F = 1.0MHz)

| Symbol           | Parameter <sup>(1)</sup> | Conditions            | Typ. | Max. | Unit |
|------------------|--------------------------|-----------------------|------|------|------|
| C <sub>IN</sub>  | Input Capacitance        | V <sub>IN</sub> = 0V  | 5    | 7    | pF   |
| C <sub>OUT</sub> | Output Capacitance       | V <sub>OUT</sub> = 0V | 7    | 9    | pF   |
| C <sub>I/O</sub> | I/O Port Capacitance     | V <sub>IN</sub> = 0V  | 7    | 9    | pF   |

### NOTE:

- As applicable to the device type.

## PIN DESCRIPTION

| Pin Names         | Description                               |
|-------------------|---|
| x $\overline{OE}$ | 3-State Output Enable Inputs (Active LOW) |
| xAx               | Data Inputs <sup>(1)</sup>                |
| xYx               | 3-State Outputs                           |

### NOTE:

- These pins have "Bus-Hold". All other pins are standard inputs, outputs, or I/Os.

## FUNCTION TABLE (EACH 4-BIT BUFFER)<sup>(1)</sup>

| Inputs            |     | Outputs |
|-------------------|-----|---------|
| x $\overline{OE}$ | xAx | xYx     |
| L                 | H   | H       |
| L                 | L   | L       |
| H                 | X   | Z       |

### NOTE:

- H = HIGH Voltage Level  
X = Don't Care  
L = LOW Voltage Level  
Z = High-Impedance

## DC ELECTRICAL CHARACTERISTICS OVER OPERATING RANGE

Following Conditions Apply Unless Otherwise Specified:

Operating Condition:  $T_A = -40^{\circ}\text{C}$  to  $+85^{\circ}\text{C}$

| Symbol   | Parameter  | Test Conditions   |                                  | Min. | Typ. <sup>(1)</sup> | Max. | Unit |
|--|--|---|----------------------------------|------|---------------------|------|------|
| V <sub>IH</sub>  | Input HIGH Voltage Level                               | V <sub>CC</sub> = 2.3V to 2.7V  |                                  | 1.7  | —                   | —    | V    |
|  |  | V <sub>CC</sub> = 2.7V to 3.6V  |                                  | 2    | —                   | —    |      |
| V <sub>IL</sub>  | Input LOW Voltage Level                                | V <sub>CC</sub> = 2.3V to 2.7V  |                                  | —    | —                   | 0.7  | V    |
|  |  | V <sub>CC</sub> = 2.7V to 3.6V  |                                  | —    | —                   | 0.8  |      |
| I <sub>IH</sub>  | Input HIGH Current                                     | V <sub>CC</sub> = 3.6V  | V <sub>I</sub> = V <sub>CC</sub> | —    | —                   | ±5   | μA   |
| I <sub>IL</sub>  | Input LOW Current                                      | V <sub>CC</sub> = 3.6V  | V <sub>I</sub> = GND             | —    | —                   | ±5   | μA   |
| I <sub>OZH</sub><br>I <sub>OZL</sub>                     | High Impedance Output Current<br>(3-State Output pins) | V <sub>CC</sub> = 3.6V  |                                  | —    | —                   | ±10  | μA   |
|  |  | V <sub>O</sub> = GND  |                                  | —    | —                   | ±10  |      |
| V <sub>IK</sub>  | Clamp Diode Voltage                                    | V <sub>CC</sub> = 2.3V, I <sub>IN</sub> = -18mA                             |                                  | —    | -0.7                | -1.2 | V    |
| V <sub>H</sub>   | Input Hysteresis                                       | V <sub>CC</sub> = 3.3V  |                                  | —    | 100                 | —    | mV   |
| I <sub>CC1</sub><br>I <sub>CC2</sub><br>I <sub>CC3</sub> | Quiescent Power Supply Current                         | V <sub>CC</sub> = 3.6V<br>V <sub>IN</sub> = GND or V <sub>CC</sub>          |                                  | —    | 0.1                 | 40   | μA   |
| ΔI <sub>CC</sub>   | Quiescent Power Supply Current Variation               | One input at V <sub>CC</sub> - 0.6V, other inputs at V <sub>CC</sub> or GND |                                  | —    | —                   | 750  | μA   |

**NOTE:**

1. Typical values are at V<sub>CC</sub> = 3.3V, +25°C ambient.

## BUS-HOLD CHARACTERISTICS

| Symbol                                 | Parameter <sup>(1)</sup>         | Test Conditions        |  | Min.                       | Typ. <sup>(2)</sup> | Max. | Unit |
|--|----------------------------------|------------------------|--|----------------------------|---------------------|------|------|
| I <sub>BHH</sub><br>I <sub>BHL</sub>   | Bus-Hold Input Sustain Current   | V <sub>CC</sub> = 3V   |  | —                          | —                   | —    | μA   |
|  |                                  | V <sub>I</sub> = 0.8V  |  | 75                         | —                   | —    |      |
| I <sub>BHH</sub><br>I <sub>BHL</sub>   | Bus-Hold Input Sustain Current   | V <sub>CC</sub> = 2.3V |  | —                          | —                   | —    | μA   |
|  |                                  | V <sub>I</sub> = 0.7V  |  | 45                         | —                   | —    |      |
| I <sub>BHHO</sub><br>I <sub>BHLO</sub> | Bus-Hold Input Overdrive Current | V <sub>CC</sub> = 3.6V |  | V <sub>I</sub> = 0 to 3.6V |                     | ±500 | μA   |

**NOTES:**

1. Pins with Bus-Hold are identified in the pin description.
2. Typical values are at V<sub>CC</sub> = 3.3V, +25°C ambient.

## OUTPUT DRIVE CHARACTERISTICS

| Symbol          | Parameter           | Test Conditions <sup>(1)</sup> |                           | Min.                  | Max. | Unit |
|-----------------|---------------------|--------------------------------|---------------------------|-----------------------|------|------|
| V <sub>OH</sub> | Output HIGH Voltage | V <sub>CC</sub> = 2.3V to 3.6V | I <sub>OH</sub> = - 0.1mA | V <sub>CC</sub> - 0.2 | —    | V    |
|                 |                     | V <sub>CC</sub> = 2.3V         | I <sub>OH</sub> = - 6mA   | 2                     | —    |      |
|                 |                     | V <sub>CC</sub> = 2.3V         | I <sub>OH</sub> = - 12mA  | 1.7                   | —    |      |
|                 |                     | V <sub>CC</sub> = 2.7V         |                           | 2.2                   | —    |      |
|                 |                     | V <sub>CC</sub> = 3V           |                           | 2.4                   | —    |      |
|                 |                     | V <sub>CC</sub> = 3V           | I <sub>OH</sub> = - 24mA  | 2                     | —    |      |
| V <sub>OL</sub> | Output LOW Voltage  | V <sub>CC</sub> = 2.3V to 3.6V | I <sub>OL</sub> = 0.1mA   | —                     | 0.2  | V    |
|                 |                     | V <sub>CC</sub> = 2.3V         | I <sub>OL</sub> = 6mA     | —                     | 0.4  |      |
|                 |                     |                                | I <sub>OL</sub> = 12mA    | —                     | 0.7  |      |
|                 |                     | V <sub>CC</sub> = 2.7V         | I <sub>OL</sub> = 12mA    | —                     | 0.4  |      |
|                 |                     | V <sub>CC</sub> = 3V           | I <sub>OL</sub> = 24mA    | —                     | 0.55 |      |

**NOTE:**  
1. V<sub>IH</sub> and V<sub>IL</sub> must be within the min. or max. range shown in the DC ELECTRICAL CHARACTERISTICS OVER OPERATING RANGE table for the appropriate V<sub>CC</sub> range. T<sub>A</sub> = - 40°C to + 85°C.

## OPERATING CHARACTERISTICS, T<sub>A</sub> = 25°C

| Symbol | Parameter                                      | Test Conditions                 | V <sub>CC</sub> = 2.5V ± 0.2V | V <sub>CC</sub> = 3.3V ± 0.3V | Unit |
|--------|--|---------------------------------|-------------------------------|-------------------------------|------|
|        |  |                                 | Typical                       | Typical                       |      |
| CPD    | Power Dissipation Capacitance Outputs enabled  | C <sub>L</sub> = 0pF, f = 10Mhz | 16                            | 19                            | pF   |
| CPD    | Power Dissipation Capacitance Outputs disabled |                                 | 4                             | 5                             |      |

## SWITCHING CHARACTERISTICS<sup>(1)</sup>

| Symbol             | Parameter                  | V <sub>CC</sub> = 2.5V ± 0.2V |      | V <sub>CC</sub> = 2.7V |      | V <sub>CC</sub> = 3.3V ± 0.3V |      | Unit |
|--------------------|----------------------------|-------------------------------|------|------------------------|------|-------------------------------|------|------|
|                    |                            | Min.                          | Max. | Min.                   | Max. | Min.                          | Max. |      |
| t <sub>PLH</sub>   | Propagation Delay          | 1                             | 3.7  | —                      | 3.6  | 1                             | 3    | ns   |
| t <sub>PHL</sub>   | xAx to xYx                 |                               |      |                        |      |                               |      |      |
| t <sub>PZH</sub>   | Output Enable Time         | 1                             | 5.7  | —                      | 5.4  | 1                             | 4.4  | ns   |
| t <sub>PZL</sub>   | x $\overline{OE}$ to xYx   |                               |      |                        |      |                               |      |      |
| t <sub>PHZ</sub>   | Output Disable Time        | 1                             | 5.2  | —                      | 4.6  | 1                             | 4.1  | ns   |
| t <sub>PLZ</sub>   | x $\overline{OE}$ to xYx   |                               |      |                        |      |                               |      |      |
| t <sub>SK(o)</sub> | Output Skew <sup>(2)</sup> | —                             | —    | —                      | —    | —                             | 500  | ps   |

**NOTES:**  
1. See TEST CIRCUITS AND WAVEFORMS. T<sub>A</sub> = - 40°C to + 85°C.  
2. Skew between any two outputs of the same package and switching in the same direction.

## TEST CIRCUITS AND WAVEFORMS

### TEST CONDITIONS

| Symbol            | V <sub>CC</sub> <sup>(1)</sup> =3.3V±0.3V | V <sub>CC</sub> <sup>(1)</sup> =2.7V | V <sub>CC</sub> <sup>(2)</sup> =2.5V±0.2V | Unit |
|-------------------|---|--------------------------------------|---|------|
| V <sub>LOAD</sub> | 6   | 6                                    | 2 x V <sub>CC</sub>                       | V    |
| V <sub>IH</sub>   | 2.7                                       | 2.7                                  | V <sub>CC</sub>                           | V    |
| V <sub>T</sub>    | 1.5                                       | 1.5                                  | V <sub>CC</sub> / 2                       | V    |
| V <sub>LZ</sub>   | 300                                       | 300                                  | 150                                       | mV   |
| V <sub>HZ</sub>   | 300                                       | 300                                  | 150                                       | mV   |
| C <sub>L</sub>    | 50  | 50                                   | 30  | pF   |

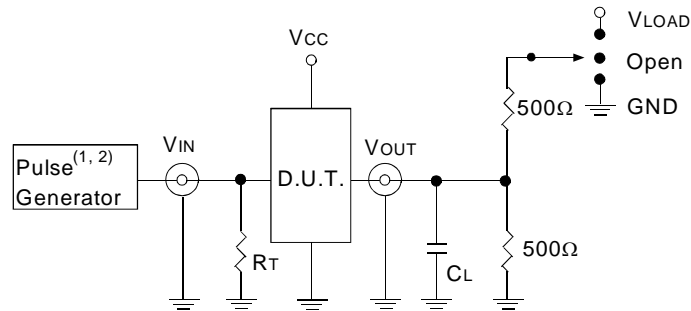

Test Circuit for All Outputs

#### DEFINITIONS:

C<sub>L</sub> = Load capacitance: includes jig and probe capacitance.  
R<sub>T</sub> = Termination resistance: should be equal to Z<sub>OUT</sub> of the Pulse Generator.

#### NOTES:

1. Pulse Generator for All Pulses: Rate ≤ 1.0MHz; t<sub>r</sub> ≤ 2.5ns; t<sub>r</sub> ≤ 2.5ns.
2. Pulse Generator for All Pulses: Rate ≤ 1.0MHz; t<sub>r</sub> ≤ 2ns; t<sub>r</sub> ≤ 2ns.

### SWITCH POSITION

| Test                                    | Switch            |
|---|-------------------|
| Open Drain<br>Disable Low<br>Enable Low | V <sub>LOAD</sub> |
| Disable High<br>Enable High             | GND               |
| All Other Tests                         | Open              |

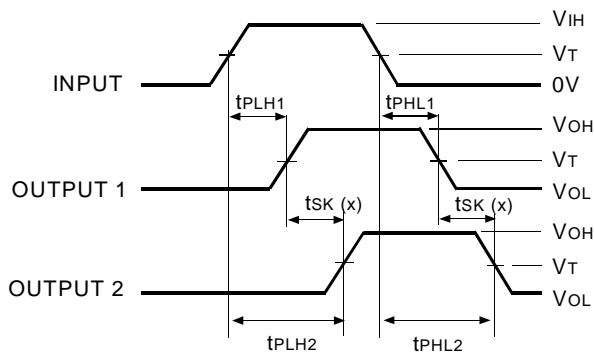

$$tsk(x) = |t_{PLH2} - t_{PLH1}| \text{ or } |t_{PHL2} - t_{PHL1}|$$

Output Skew - *tsk(x)*

#### NOTES:

1. For tsk(o) OUTPUT1 and OUTPUT2 are any two outputs.
2. For tsk(b) OUTPUT1 and OUTPUT2 are in the same bank.

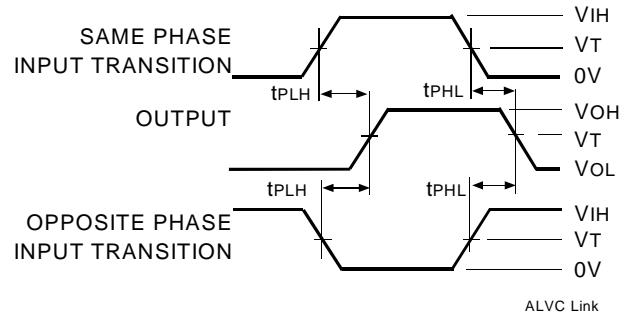

Propagation Delay

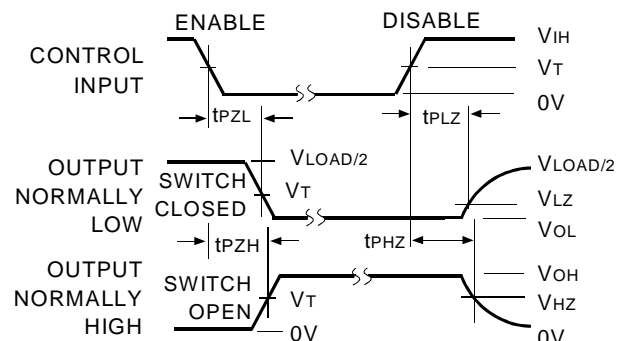

Enable and Disable Times

#### NOTE:

1. Diagram shown for input Control Enable-LOW and input Control Disable-HIGH.

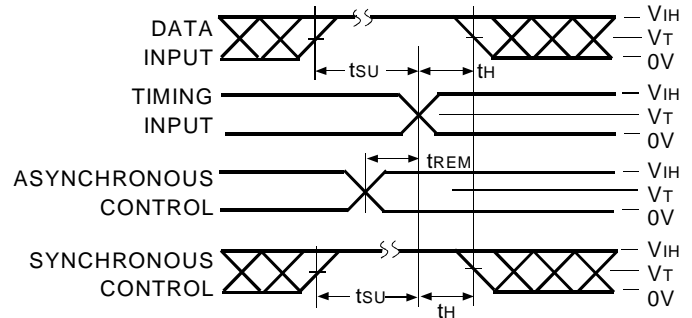

ALVC Link

Set-up, Hold, and Release Times

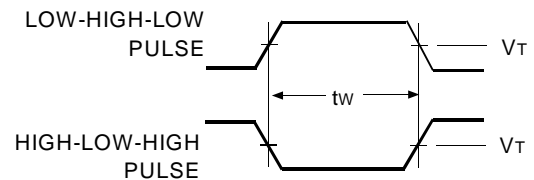

Pulse Width

## ORDERING INFORMATION

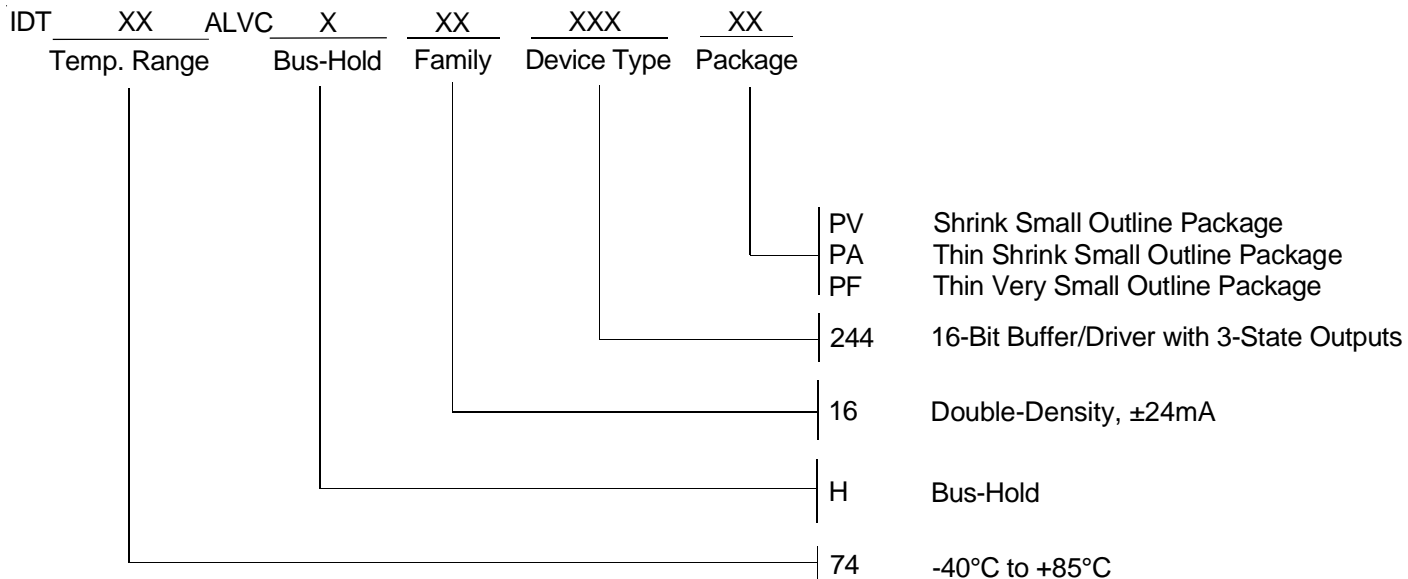

**CORPORATE HEADQUARTERS**  
2975 Stender Way  
Santa Clara, CA 95054

**for SALES:**  
800-345-7015 or 408-727-6116  
fax: 408-492-8674  
www.idt.com

**for Tech Support:**  
logichelp@idt.com  
(408) 654-6459