

KSM-90 TM1N

The KSM-90 TM1N consist of a PIN Photodiode of high speed and a preamplifier IC in the package as an receiver for Infrared remote control systems

Features

- Wide angle design
- Supply-voltage range : 4.5V to 5.5V
- Shielded against electrical field disturbance
- Enhanced immunity against ambient light disturbances
- Enhanced reception distance
- Continuous data transmission possible (NRZ 1000 bit/s)
- Available for carrier frequencies between 32.7KHz to 56.9KHz
- TTL and CMOS compatible

Applications

- Audio & Video Applications (TV, VTR, Audio, DVDP, CDP)
- Home Appliances (Air conditioner, Computer, Camcorder)
- Wireless Toys
- Remote Control Equipment

DIMENSIONS

(Unit : mm)

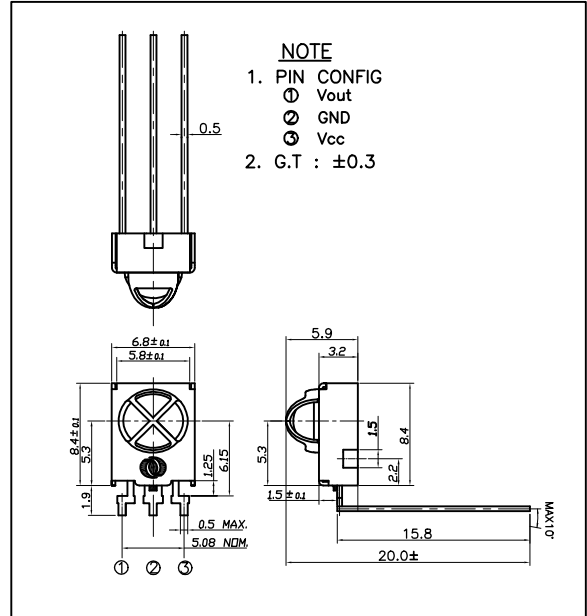

Maximum Ratings

[Ta=25]

Parameter	Symbol	Ratings	Unit
Supply Voltage	Vcc	6.0	V
Operating Temperature	Topr	-10 ~ +60	
Storage Temperature	Tstg	-20 ~ +75	
Soldering Temperature	Tsol	260 (Max 5 sec)	

B.P.F Center Frequency

Model No.	B.P.F Center Frequency(kHz)
KSM-901TM1N	40.0
KSM-902TM1N	36.7
KSM-903TM1N	37.9
KSM-904TM1N	32.7
KSM-905TM1N	56.9

Electro-Optical Characteristics

[Ta=25 , Vcc=5.0V]

Parameter	Symbol	Condition	Min.	Typ.	Max.	Unit	
Recommended Supply Voltage	Vcc		4.5	5	5.5	V	
Current Consumption	Icc	No signal input	-	1.2	2.2	mA	
Peak Wavelength *1	p		-	940	-	nm	
B.P.F Center Frequency	fo		-	37.9	-	kHz	
Transmission Distance *1	lm	250 ± 50lx	0 °	25	-	-	
			± 30 °	21	-	-	
High level Output voltage *1	V _{OH}	30cm over the ray axis	4.5	5.0	-	V	
Low level Output voltage *1	V _{OL}		-	0.1	0.5	V	
High level Output Pulse Width *1	T _{WH}	Burst wave=600μs	500	600	700	μs	
Low level Output Pulse Width *1	T _{WL}	Period = 1.2ms	500	600	700	μs	
Output Form	Active Low Output						

*1. It specifies the maximum distance between emitter and detector that the output wave form satisfies the standard under the conditions below against the standard transmitter.

- 1) Measuring place : Indoor without extreme reflection of light
- 2) Ambient light source : Detecting surface illumination shall be irradiate 200 ± 50lx under ordinary white fluorescence lamp without high frequency lightning
- 3) Standard transmitter : Burst wave of standard transmitter shall be arranged to 50mVP-P under the measuring circuit

KSM-90 □ TM1N

Measuring Method [Ta=25°C]

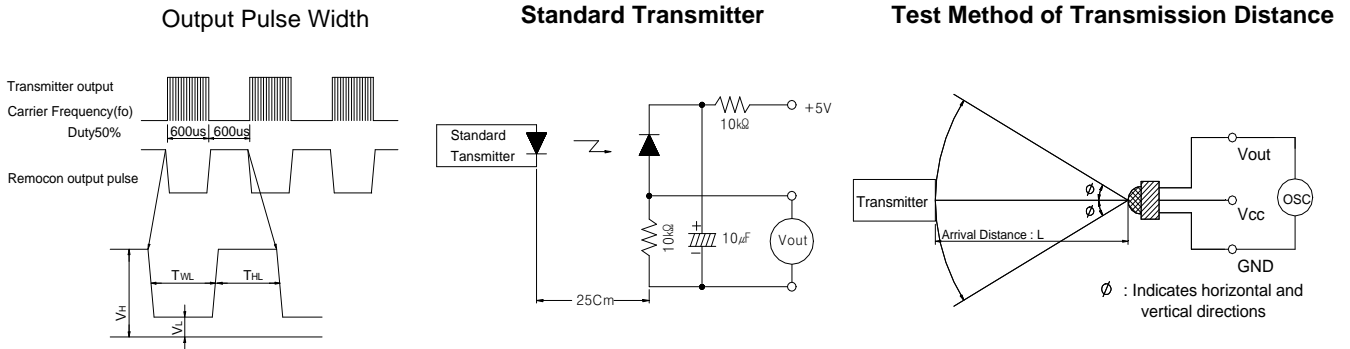

Typical Characteristics Curve [Ta=25°C]

Relative reception distance Vs. Supply voltage

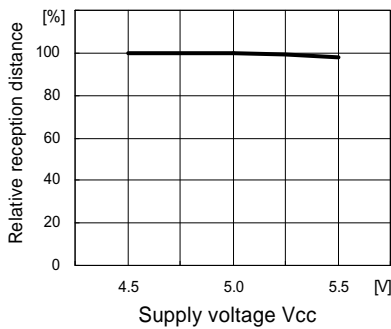

Relative reception distance Vs. Ambient temperature

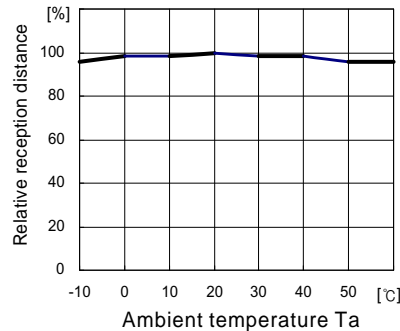

Radiant pattern

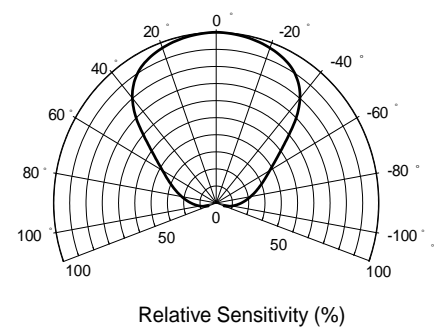

Standard Application Circuit with R-C Decoupling Filter

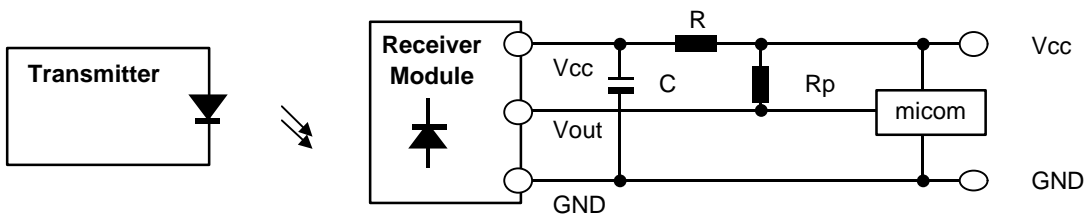

*1 Recommended Circuit Description

- 1) Transmitter(IRED) drive current
: IFP = 300mA_{P-P} ~ 600mA_{P-P}
- 2) R-C Decoupling Filter with Lower Cut-off Frequency
: R=100Ω , C=47µF ⇒ fc = 1/2 π RC = 33.9Hz
- 3) External pull-up resistor(optional)
: 10kΩ over