

Features

- Wake-up Function for a Microcontroller with Preamble Detection
- 1 mV_{rms} Sensitivity
- 1 µA Standby Current
- Power Supply: 2 V to 4.2 V
- Baud Rate: up to 4 kbps (ASK Manchester Modulation)
- Operation Temperature: up to 125°C
- Withstands +175°C
- Few External Components

Application

- Tire Pressure Monitoring (TPM)

Description

The ATA5283 is a 125 kHz ultra-low power receiver used for the wake-up function of Tire Pressure Monitoring (TPM) application. The sensitive input stage of the IC amplifies and demodulates the carrier signal from the antenna coil to a digital output signal for a microcontroller. During the standby mode the preamble detection unit monitors the incoming signal and activates the wake-up output and the data output, if the IC receives a proper 125 kHz carrier signal.

By combining the IC with an antenna coil, a microcontroller, an RF transmitter/transceiver, a battery, temperature- and pressure sensor, it is possible to design a complete Tire Pressure Monitoring system (TPM).

Figure 1. Block Diagram

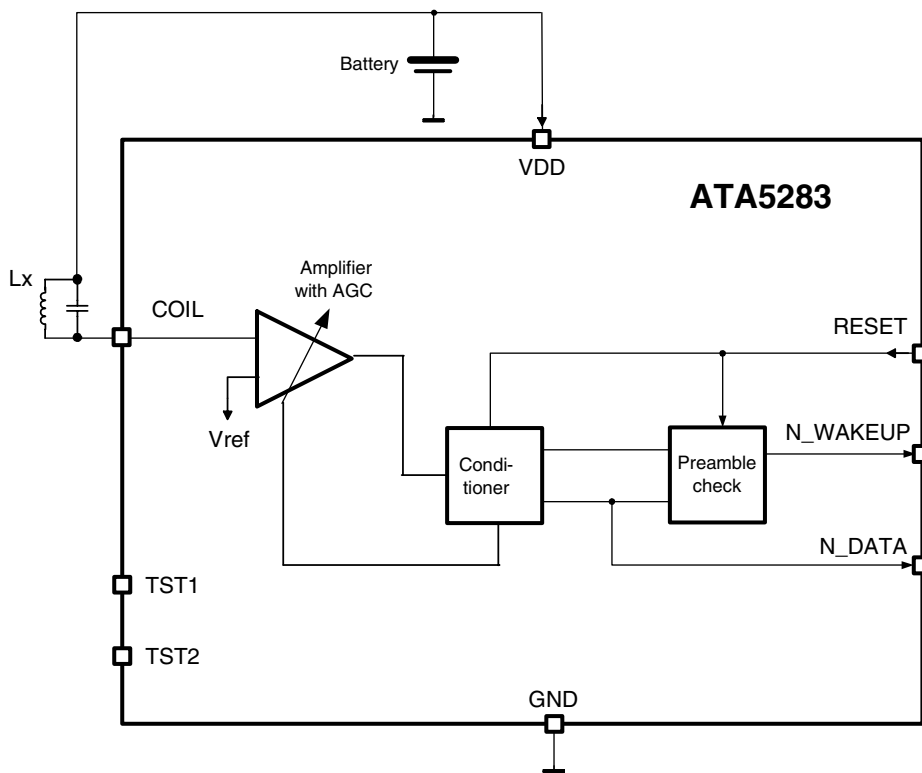

Interface IC for 125 kHz Wake-up Function

ATA5283

Preliminary



Pin Configuration

Figure 2. Pinning TSSOP8L

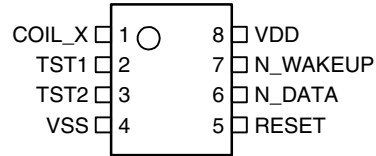

Pin Description

Pin	Symbol	Function
1	COIL	Antenna coil input
2	TST1	Test pin (reserved)
3	TST2	Test pin (reserved)
4	VSS	Signal ground
5	RESET	External reset input
6	N_DATA	Data signal
7	N_WAKEUP	Low active wake-up signal for microcontroller
8	VDD	Battery voltage

Functional Description

The ATA5283 is an ultra-low power ASK receiver. Without a carrier signal it operates in the standby listen mode. In this mode it monitors the coil input with a very low current consumption. To activate the IC and the connected control unit, the transmitting stage must send the preamble carrier burst. After a preamble is detected the IC is activated. It adapts the gain of the input stage and enables the wake-up and the data output. The first gap at the end of the preamble generates a wake-up signal for the microcontroller. After that the receiver outputs the data signal at N_DATA. To return the IC into the standby listen mode it must be reset via the RESET input.

AGC Amplifier

The input stage contains an Automatic Gain Control (AGC) amplifier to amplify the input signal from the coil. The gain is adjusted by the automatic gain control circuit if a preamble signal is detected. The high dynamic range of the AGC enables the IC to operate with input signals from 1 mV_{rms} to $1.1\text{ V}_{\text{rms}}$. After the AGC settling time the amplifier output delivers a 125 kHz signal with an amplitude adjusted for the following evaluation circuits' preamble detection, signal conditioner, wake-up.

Preamble Detection

Before data transmission the IC stays in standby listen mode. To prevent the circuit from unintended operations in a noisy environment the preamble detection circuit checks the input signal. A valid signal is detected by a counter after 192 carrier periods without interrupts. Short interrupts which are suppressed by the signal conditioner are tolerated. When a valid carrier (preamble) is found the circuit starts the automatic gain control. It requires up to 512 carrier periods to settling. The complete preamble should have 704 carrier periods minimum. The preamble is terminated and the data transfer is started with the first gap (Start Gap) in the carrier (see Figure 3).

Figure 3. Communication Protocol

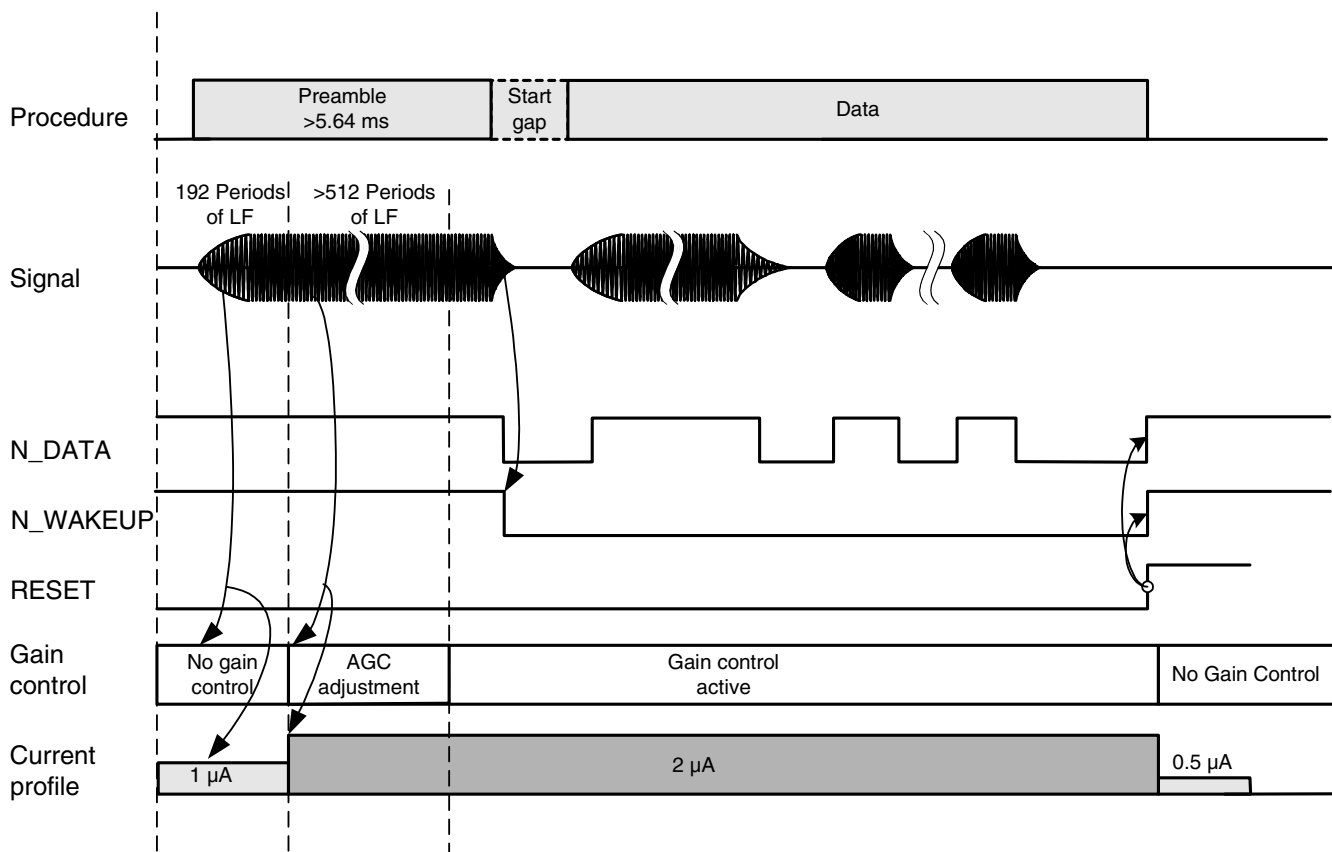

Automatic Gain Control

For a correct demodulation the signal conditioner needs appropriate internal signal amplitude. To control the input signal the ATA5283 has a built in digital AGC. The gain control circuit regulates the internal signal amplitude to the reference value (Ref2, Figure 4). It decreases the gain by one step if the internal signal exceeds the reference level for two periods and it increases the gain by one step if eight periods do not achieve the reference level. In the standby listen mode the gain is reset to the maximum value. If a valid preamble signal (192 valid carrier clocks) is detected the automatic gain control is activated.

Note: With the variation of the gain the coil input impedance changes from high impedance to minimal 143 k Ω because of the internal regulator circuit (see Figure 10).

Figure 4. Automatic Gain Control

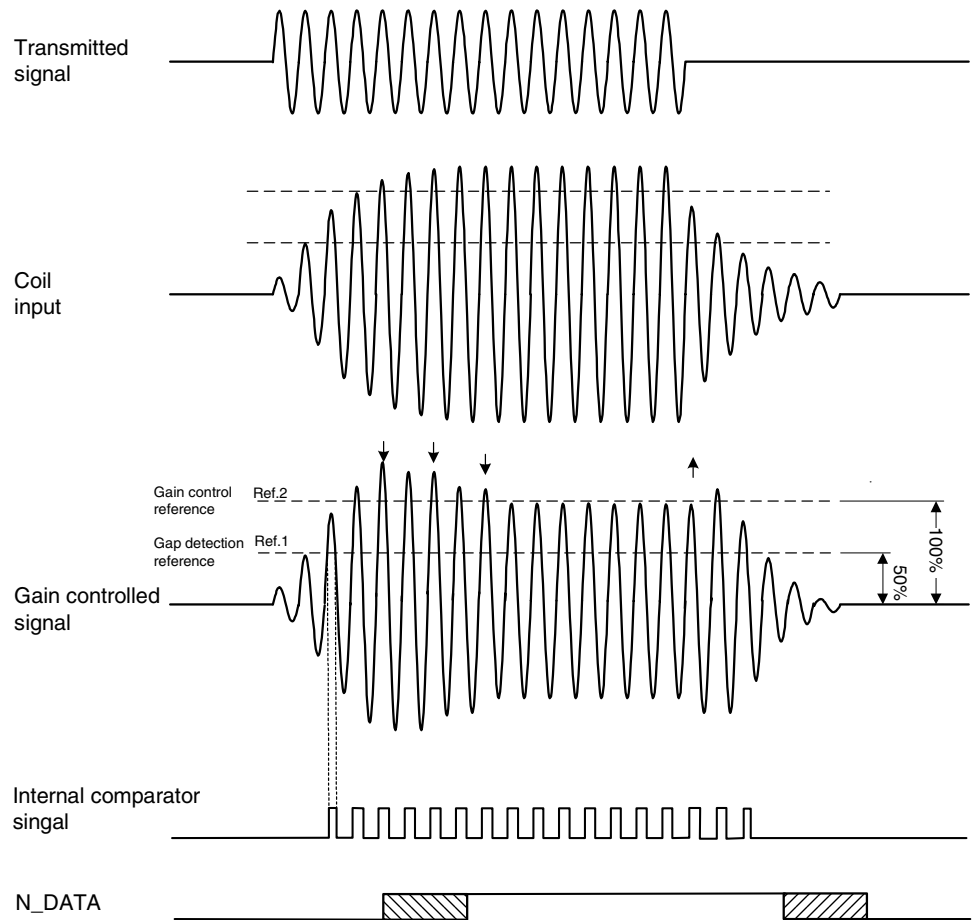

Signal Conditioner

The signal conditioner demodulates the amplifier output signal and converts it to a binary signal. It compares the carrier signal with the 50% reference level (see Ref1 in Figure 5) and delivers a logical 1, if the carrier signal stays below the reference and a logical 0, if it exceeds the reference level. A smoothing filter suppresses the space between the half-waves as well as a few missing periods in the carrier and glitches during the gaps.

The output signal of the signal conditioner is used as the internal data signal for the data output, the wake-up logic and the preamble detection.

The timing of the demodulated data signal is delayed related to the signal at the transmitting end. This delay is a function of the carrier frequency, the behavior of the smoothing filter and the antenna Q-factor. The smoothing filter causes a delay of 3 to 6 periods (see t_b and t_d in Figure 5). The rest of the delay is caused by the build-up time of the antenna signal and is conditioned on the Q-factor (see t_a and t_c in Figure 5).

Figure 5. Output Timing

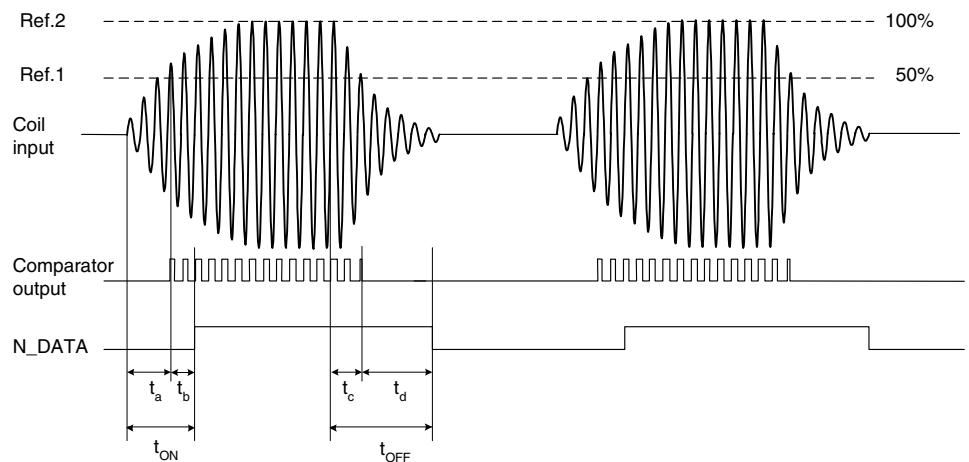

The following diagrams show the delay of the data signal as a function of the antenna Q-factor.

Figure 6. Turn On Delay Time (t_{ON}) versus Antenna Q-Factor

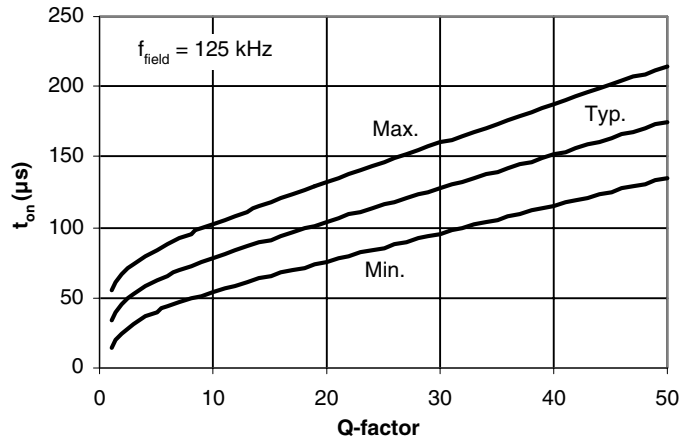
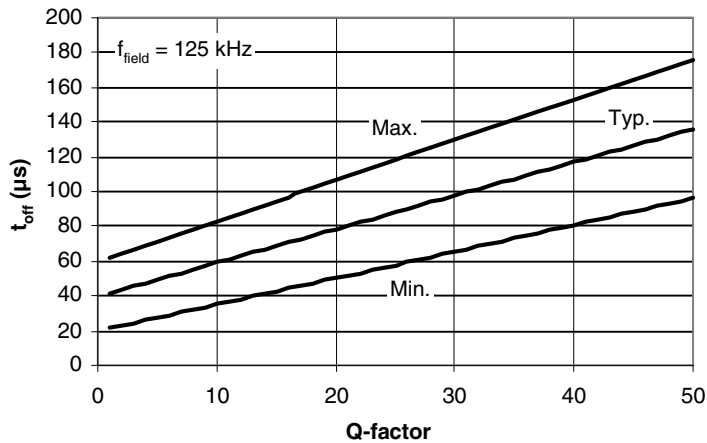

Figure 7. Turn Off Delay Time (t_{off}) versus Antenna Q-Factor



Data Output

The data output N_DATA outputs the demodulated and digitized LF signal according to the envelope of the antenna input signal. In the standby mode the N_DATA output is disabled and set to level 1. It is enabled by the wake-up signal and it outputs 1 level if the IC detects the carrier signal and a 0 level during the gaps (see Figure 3).

As the circuit does not check the received data (except the preamble), it is up to the user to choose the kind of encoding (pulse distance, Manchester, bi-phase...) wanted.

Wake-up Signal

The wake-up signal (N_WAKEUP) indicates that the ATA5283 has detected the end of a preamble signal and has left the standby mode. It can be used as a wake-up or a chip select signal for an external device (see Figure 3).

After a preamble is detected the first valid gap (Start Gap) sets the N_WAKEUP output to low and enables the data output N_DATA. The N_WAKEUP holds the low level until the IC is reset to the standby mode by a reset signal.

Figure 9. Pin Connection and Pin Protection

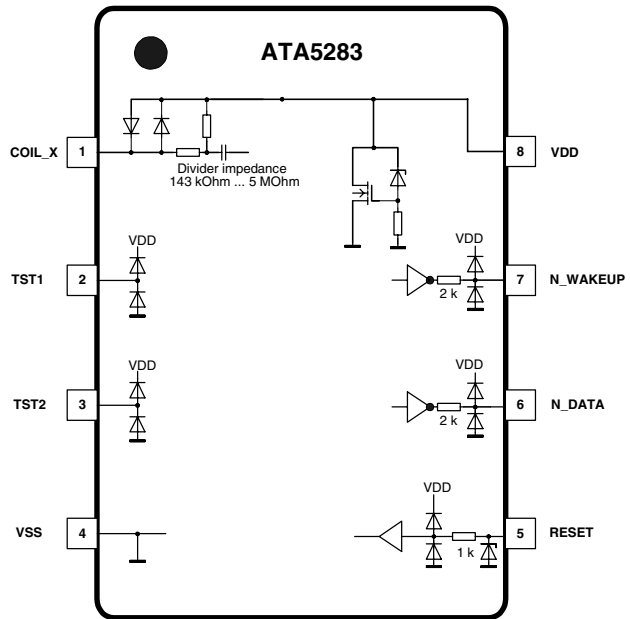
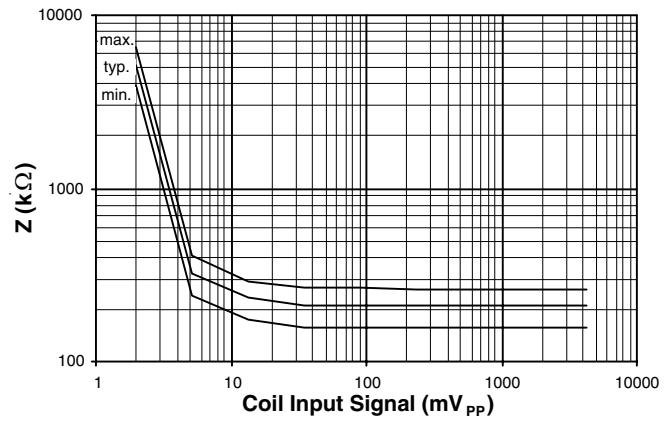

Figure 10. Coil Input Impedance



Absolute Maximum Ratings

Parameters	Symbol	Value	Unit
Power supply	V_{DD}	-0.3 to +6.5	V
Input voltage (except coil inputs)	V_{IN}	$V_{SS}-0.3 < V_{IN} < V_{DD} + 0.3$	V
Input current coil	I_{CI}	± 10	mA
Input voltage coil	V_{CI}	$V_{DD}-3.5 < V_{CI} < V_{DD} + 3.5$	V
ESD protection (human body)	V_{ESD}	4	kV
Operating temperature range	T_{amb}	-40 to +125	°C
Withstanding 175°C	t_{TEMP}	30	min.
Storage temperature range	T_{stg}	-40 to +150	°C
Soldering temperature	T_{sld}	260	°C

Thermal Resistance

Parameters	Symbol	Value	Unit
Thermal resistance junction ambient	R_{thJA}	210	K/W

Operating Range

Parameters	Symbol	Value	Unit
Power supply range	V_{DD}	2 to 4.2	V
Operating temperature range	T_{OP}	-40 to +125	°C

Electrical Characteristics

$V_{SS} = 0$ V, $V_{DD} = 2$ V to 4.2 V, $T_{amb} = -40$ °C to +105°C, characterized up to 125°C, unless other specified

No.	Parameters	Test Conditions	Pin	Symbol	Min.	Typ.	Max.	Unit	Type*
1	Power Supply and Coil Limiter								
1.1	Power supply		8	V_{DD}	2	3.2	4.2	V	A
1.2	Reset supply current -40		1, 2, 3, 8	I_{DDR}		0.5	TBD	μ A	A
	Reset supply current +25						TBD	μ A	A
	Reset supply current +85						TBD	μ A	C
	Reset supply current +105						TBD	μ A	A
	Reset supply current +125						TBD	μ A	C
1.3	Supply current (standby listen mode) -40		1, 2, 3, 8	I_{DDL}		1	1.4	μ A	A
	Supply current (standby listen mode) +25						1.5	μ A	A
	Supply current (standby listen mode) +85						1.6	μ A	C
	Supply current (standby listen mode) +105						1.6	μ A	A
	Supply current (standby listen mode) +125						1.6	μ A	C

*) Type means: A = 100% tested, B = 100% correlation tested, C = Characterized on samples, D = Design parameter

Electrical Characteristics (Continued)

$V_{SS} = 0\text{ V}$, $V_{DD} = 2\text{ V}$ to 4.2 V , $T_{amb} = -40^{\circ}\text{C}$ to $+105^{\circ}\text{C}$, characterized up to 125°C , unless other specified

No.	Parameters	Test Conditions	Pin	Symbol	Min.	Typ.	Max.	Unit	Type*
1.4	Supply current (AGC active) -40		1,2,3, 8	I_{DD}		2	4.0	μA	A
	Supply current (AGC active) +25						4.1	μA	A
	Supply current (AGC active) +85						4.2	μA	C
	Supply current (AGC active) +105						4.2	μA	A
	Supply current (AGC active) +125						4.2	μA	C
1.5	Coil input voltage referred to V_{DD} (Input coil limiter for channels X, Y, Z)	$I_{CI} = \pm 1\text{ mA}$ $V_{DD} = 2\text{ V}$	1-3	V_C		± 1.4		Vp	A
		$I_{CI} = \pm 1\text{ mA}$ $V_{DD} = 3.2\text{ V}$				± 1.6		Vp	A
		$I_{CI} = \pm 1\text{ mA}$ $V_{DD} = 2\text{ V}$				± 1.8		Vp	A
2	Amplifiers								
2.1	Wake-up sensitivity	125 kHz input signal	7	V_{SENS}		1	2	mV_{rms}	A
2.2	Bandwidth	Without coil	6	B_W		230		kHz	C
2.3	Upper corner frequency	Without coil	6	f_u		200		kHz	C
2.4	Lower corner frequency	Without coil	6	f_o		30		kHz	C
2.5	Input impedance	$f = 125\text{ kHz}$	1-3	R_{IN}	143			$\text{k}\Omega$	A
3	Automatic Gain Control								
3.1	Preamble detection time	$V_{IN} \geq 3\text{ mV}_{PP}$ at 125 kHz		t_{DAGC}		192		Periods	B
3.2	AGC adjustment time	$f = 125\text{ kHz}$ $V_{IN} = 3\text{ mV}_{PP}$ $V_{IN} = 3\text{ mV}_{PP}$ $V_{IN} = 3\text{ mV}_{PP}$ $V_{IN} = 3\text{ mV}_{PP}$ $V_{IN} = 3\text{ mV}_{PP}$		t_{AGC} t_{AGC} t_{AGC} t_{AGC} t_{AGC}		0	512	Periods	C
						96			
						220			
						292			
						450			
3.3	Signal change rate (gap detection)		1	t_{EOS}			24	Periods	C
3.4	AGC correction time (no gap detection)	Coil input signal: 50 to 100% changing	1	t_{CORR}			52	Periods	C
		Coil input signal: 100 to 50% changing	1	t_{CORR}			208	Periods	C
3.5	Data rate ($Q < 20$)	125 kHz ASK		DR		4		kbits/s	A
3.6	Delay time RF signal to data	125 kHz ASK		t_{ON}		40		μs	A
3.7	Delay time RF signal to data	125 kHz ASK		t_{OFF}		40		μs	A

*) Type means: A = 100% tested, B = 100% correlation tested, C = Characterized on samples, D = Design parameter

Electrical Characteristics (Continued)

$V_{SS} = 0\text{ V}$, $V_{DD} = 2\text{ V to } 4.2\text{ V}$, $T_{amb} = -40^{\circ}\text{C to } +105^{\circ}\text{C}$, characterized up to 125°C , unless other specified

No.	Parameters	Test Conditions	Pin	Symbol	Min.	Typ.	Max.	Unit	Type*
4	Interface								
4.1	Reset input level high		5	V_{HRESET}	$0.8 \times V_{DD}$		V_{DD}	V	A
4.2	Reset input level low		5	V_{LRESET}	0		$0.2 \times V_{DD}$	V	C
4.3	Reset input leakage current low	$V_{RESET} = V_{SS}$	5	I_{IL}	-0.2		0	μA	A
4.4	Reset input leakage current high	$V_{RESET} = V_{DD}$	5	I_{IH}	0		0.2	μA	A
4.5	N_WAKEUP output level high	$I_{NWAKEUP} = -100\ \mu\text{A}$	7	V_{HNWAKE}	$0.8 \times V_{DD}$		V_{DD}	V	A
4.6	N_WAKEUP output level low	$I_{NWAKEUP} = 100\ \mu\text{A}$	7	V_{LNWAKE}	0		$0.2 \times V_{DD}$	V	A
4.7	N_DATA output level high	$I_{N_DATA} = -100\ \mu\text{A}$	6	V_{HNDATA}	$0.8 \times V_{DD}$		V_{DD}	V	A
4.8	N_DATA output level low	$I_{N_DATA} = 100\ \mu\text{A}$	6	V_{LNDATA}	0		$0.2 \times V_{DD}$	V	A
5	Power Supply and Reset								
5.1	V_{DD} power on reset threshold			V_{POR}	1	1.5	1.9	V	A
5.2	Power-up time	Switch on V_{DD} to circuit active		V_{PON}			100	ms	C
5.3	RESET reactivation caused by negative spikes on V_{DD}	$t_{BDN} = 500\ \text{ns}$	7	t_{RST}	10		100	μs	C

*) Type means: A = 100% tested, B = 100% correlation tested, C = Characterized on samples, D = Design parameter

Ordering Information

Extended Type Number	Package	Remarks
ATA5283	TSSOP8L	–

Package Information

Package: TSSOP 8L

Dimensions in mm

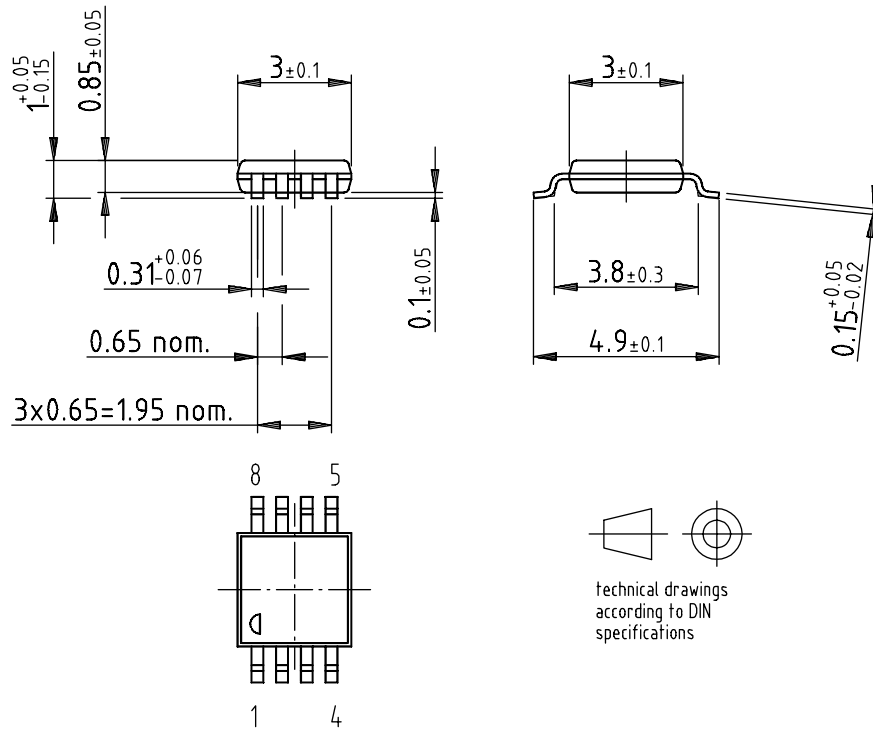

Drawing-No.: 6.543-5083.01-4

Issue: 1; 08.01.02



Atmel Headquarters

Corporate Headquarters

2325 Orchard Parkway
San Jose, CA 95131
TEL 1(408) 441-0311
FAX 1(408) 487-2600

Europe

Atmel Sarl
Route des Arsenaux 41
Case Postale 80
CH-1705 Fribourg
Switzerland
TEL (41) 26-426-5555
FAX (41) 26-426-5500

Asia

Room 1219
Chinachem Golden Plaza
77 Mody Road Tsimhatsui
East Kowloon
Hong Kong
TEL (852) 2721-9778
FAX (852) 2722-1369

Japan

9F, Tonetsu Shinkawa Bldg.
1-24-8 Shinkawa
Chuo-ku, Tokyo 104-0033
Japan
TEL (81) 3-3523-3551
FAX (81) 3-3523-7581

Atmel Operations

Memory

2325 Orchard Parkway
San Jose, CA 95131
TEL 1(408) 441-0311
FAX 1(408) 436-4314

Microcontrollers

2325 Orchard Parkway
San Jose, CA 95131
TEL 1(408) 441-0311
FAX 1(408) 436-4314

La Chantrerie
BP 70602
44306 Nantes Cedex 3, France
TEL (33) 2-40-18-18-18
FAX (33) 2-40-18-19-60

ASIC/ASSP/Smart Cards

Zone Industrielle
13106 Rousset Cedex, France
TEL (33) 4-42-53-60-00
FAX (33) 4-42-53-60-01

1150 East Cheyenne Mtn. Blvd.
Colorado Springs, CO 80906
TEL 1(719) 576-3300
FAX 1(719) 540-1759

Scottish Enterprise Technology Park
Maxwell Building
East Kilbride G75 0QR, Scotland
TEL (44) 1355-803-000
FAX (44) 1355-242-743

RF/Automotive

Theresienstrasse 2
Postfach 3535
74025 Heilbronn, Germany
TEL (49) 71-31-67-0
FAX (49) 71-31-67-2340

1150 East Cheyenne Mtn. Blvd.
Colorado Springs, CO 80906
TEL 1(719) 576-3300
FAX 1(719) 540-1759

Biometrics/Imaging/Hi-Rel MPU/ High Speed Converters/RF Datacom

Avenue de Rochepleine
BP 123
38521 Saint-Egreve Cedex, France
TEL (33) 4-76-58-30-00
FAX (33) 4-76-58-34-80

e-mail

literature@atmel.com

Web Site

<http://www.atmel.com>

© Atmel Corporation 2003.

Atmel Corporation makes no warranty for the use of its products, other than those expressly contained in the Company's standard warranty which is detailed in Atmel's Terms and Conditions located on the Company's web site. The Company assumes no responsibility for any errors which may appear in this document, reserves the right to change devices or specifications detailed herein at any time without notice, and does not make any commitment to update the information contained herein. No licenses to patents or other intellectual property of Atmel are granted by the Company in connection with the sale of Atmel products, expressly or by implication. Atmel's products are not authorized for use as critical components in life support devices or systems.

Atmel® is the registered trademark of Atmel.

Other terms and product names may be the trademarks of others.



Printed on recycled paper.