



CYPRESS

PRELIMINARY

CY7C1355V25
CY7C1357V25

256Kx36/512Kx18 Flow-Thru SRAM with NoBL™ Architecture

Features

- Pin compatible and functionally equivalent to ZBT™ devices
- Supports 133-MHz bus operations with zero wait states
— Data is transferred on every clock
- Internally self-timed output buffer control to eliminate the need to use asynchronous OE
- Registered inputs for Flow-Through operation
- Byte Write capability
- Common I/O architecture
- Single 2.5V power supply
- Fast clock-to-output times
— 6.5 ns (for 133-MHz device)
— 7.5 ns (for 117-MHz device)
— 8.5 ns (for 100-MHz device)
— 10.0 ns (for 80-MHz device)
- Clock Enable (\overline{CEN}) pin to suspend operation
- Synchronous self-timed writes
- Available in 100 TQFP & 119 BGA Packages
- Burst Capability—linear or interleaved burst order

respectively. They are designed specifically to support unlimited true back-to-back Read/Write operations without the insertion of wait states. The CY7C1355V25/CY7C1357V25 is equipped with the advanced No Bus Latency™ (NoBL™) logic required to enable consecutive Read/Write operations with data being transferred on every clock cycle. This feature dramatically improves the throughput of data through the SRAM, especially in systems that require frequent Write/Read transitions. The CY7C1355V25/CY7C1357V25 is pin compatible and functionally equivalent to ZBT devices.

All synchronous inputs pass through input registers controlled by the rising edge of the clock. The clock input is qualified by the Clock Enable (CEN) signal, which when deasserted suspends operation and extends the previous clock cycle. Maximum access delay from the clock rise is 6.5 ns (133-MHz device).

Write operations are controlled by the Byte Write Selects ($\overline{BWS}_{a,b,c,d}$ for CY7C1355V25 and $\overline{BWS}_{a,b}$ for CY7C1357V25) and a Write Enable (\overline{WE}) input. All writes are conducted with on-chip synchronous self-timed write circuitry.

Three synchronous Chip Enables (\overline{CE}_1 , \overline{CE}_2 , \overline{CE}_3) and an asynchronous Output Enable (\overline{OE}) provide for easy bank selection and output three-state control. In order to avoid bus contention, the output drivers are synchronously three-stated during the data portion of a write sequence.

Functional Description

The CY7C1355V25 and CY7C1357V25 are 2.5V, 256K by 36 and 512K by 18 Synchronous-Flow-Through Burst SRAMs,

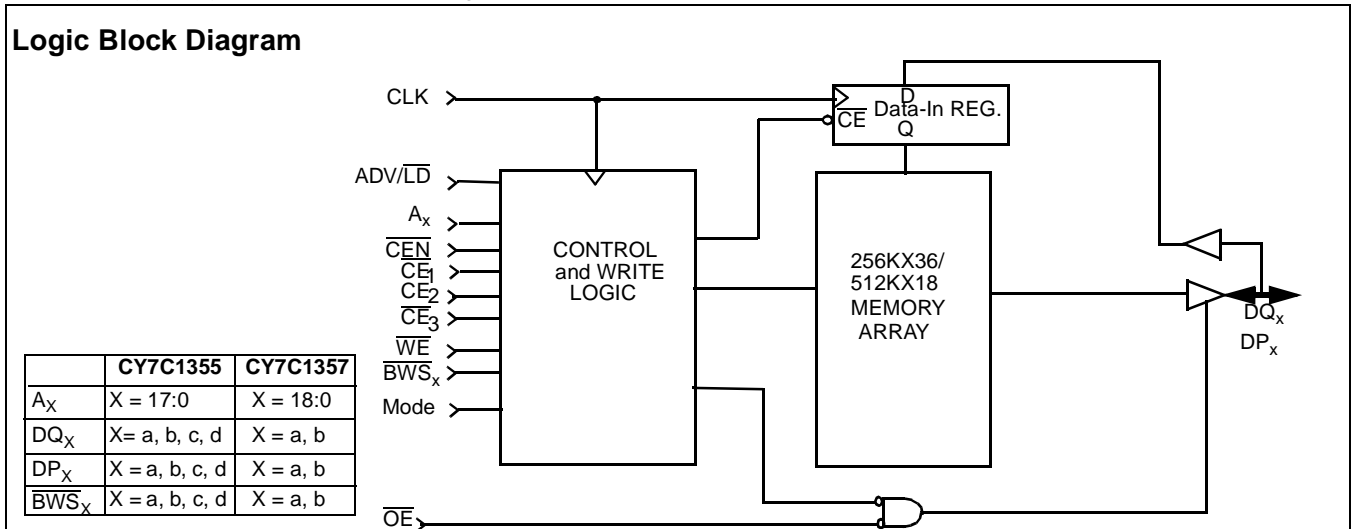

Selection Guide

		7C1355V25-133 7C1357V25-133	7C1355V25-117 7C1357V25-117	7C1355V25-100 7C1357V25-100	7C1355V25-80 7C1357V25-80
Maximum Access Time (ns)		6.5	7.5	8.5	10.0
Maximum Operating Current (mA)	Com'l	300	280	250	200
Maximum CMOS Standby Current (mA)	Com'l	10	10	10	10

Shaded areas contain advance information.

No Bus Latency and NoBL are trademarks of Cypress Semiconductor Corporation. ZBT is a trademark of Integrated Device Technology.

Pin Configurations

100-Pin TQFP Packages

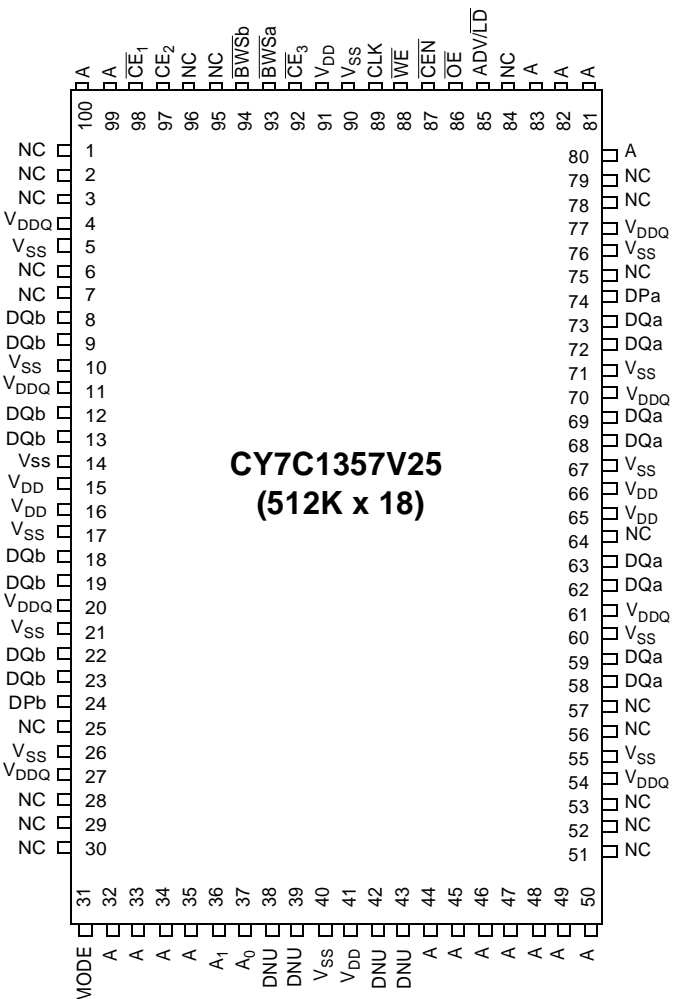
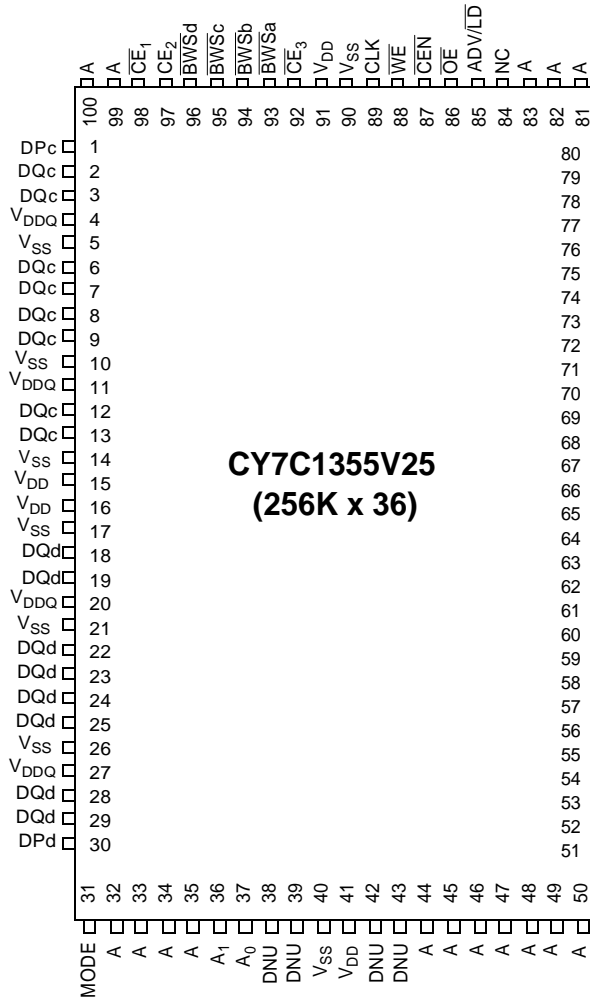

Pin Configurations (continued)
119-Ball Bump BGA
CY7C1355 (256K x 36) - 7 x 17 BGA

	1	2	3	4	5	6	7
A	V _{DDQ}	A	A	16M	A	A	V _{DDQ}
B	NC	CE ₂	A	ADV/ $\overline{\text{LD}}$	A	$\overline{\text{CE}}_3$	NC
C	NC	A	A	V _{DD}	A	A	NC
D	DQ _c	DP _c	V _{SS}	NC	V _{SS}	DP _b	DQ _b
E	DQ _c	DQ _c	V _{SS}	$\overline{\text{CE}}_1$	V _{SS}	DQ _b	DQ _b
F	V _{DDQ}	DQ _c	V _{SS}	$\overline{\text{OE}}$	V _{SS}	DQ _b	V _{DDQ}
G	DQ _c	DQ _c	$\overline{\text{BWS}}_c$	A	$\overline{\text{BWS}}_b$	DQ _b	DQ _b
H	DQ _c	DQ _c	V _{SS}	$\overline{\text{WE}}$	V _{SS}	DQ _b	DQ _b
J	V _{DDQ}	V _{DD}	V _{SS(1)}	V _{DD}	V _{SS(1)}	V _{DD}	V _{DDQ}
K	DQ _d	DQ _d	V _{SS}	CLK	V _{SS}	DQ _a	DQ _a
L	DQ _d	DQ _d	$\overline{\text{BWS}}_d$	NC	$\overline{\text{BWS}}_a$	DQ _a	DQ _a
M	V _{DDQ}	DQ _d	V _{SS}	CEN	V _{SS}	DQ _a	V _{DDQ}
N	DQ _d	DQ _d	V _{SS}	A1	V _{SS}	DQ _a	DQ _a
P	DQ _d	DP _d	V _{SS}	A0	V _{SS}	DP _a	DQ _a
R	NC	A	MODE	V _{DD}	V _{SS}	A	NC
T	NC	64M	A	A	A	32M	NC
U	V _{DDQ}	TMS	TDI	TCK	TDO	DNU	V _{DDQ}

CY7C1357 (512K x 18) - 7 x 17 BGA

	1	2	3	4	5	6	7
A	V _{DDQ}	A	A	16M	A	A	V _{DDQ}
B	NC	CE ₂	A	ADV/ $\overline{\text{LD}}$	A	$\overline{\text{CE}}_3$	NC
C	NC	A	A	V _{DD}	A	A	NC
D	DQ _b	NC	V _{SS}	NC	V _{SS}	DP _a	NC
E	NC	DQ _b	V _{SS}	$\overline{\text{CE}}_1$	V _{SS}	NC	DQ _a
F	V _{DDQ}	NC	V _{SS}	$\overline{\text{OE}}$	V _{SS}	DQ _a	V _{DDQ}
G	NC	DQ _b	$\overline{\text{BWS}}_b$	A	V _{SS}	NC	DQ _a
H	DQ _b	NC	V _{SS}	$\overline{\text{WE}}$	V _{SS}	DQ _a	NC
J	V _{DDQ}	V _{DD}	V _{SS(1)}	V _{DD}	V _{SS(1)}	V _{DD}	V _{DDQ}
K	NC	DQ _b	V _{SS}	CLK	V _{SS}	NC	DQ _a
L	DQ _b	NC	V _{SS}	NC	$\overline{\text{BWS}}_a$	DQ _a	NC
M	V _{DDQ}	DQ _b	V _{SS}	CEN	V _{SS}	NC	V _{DDQ}
N	DQ _b	NC	V _{SS}	A1	V _{SS}	DQ _a	NC
P	NC	DP _b	V _{SS}	A0	V _{SS}	NC	DQ _a
R	NC	A	MODE	V _{DD}	V _{SS}	A	NC
T	64M	A	A	32M	A	A	NC
U	V _{DDQ}	TMS	TDI	TCK	TDO	DNU	V _{DDQ}

Pin Definitions (100-Pin TQFP)

x18 Pin Location	x36 Pin Location	Name	I/O Type	Description
37, 36, 32–35, 44–50,80–83, 99, 100	37, 36, 32–35, 44–50, 81–83, 99, 100	A0 A1 A	Input- Synchronous	Address Inputs used to select one of the 266,144 address locations. Sampled at the rising edge of the CLK.
93, 94	93, 94, 95, 96	\overline{BWS}_a \overline{BWS}_b \overline{BWS}_c \overline{BWS}_d	Input- Synchronous	Byte Write Select Inputs, active LOW. Qualified with \overline{WE} to conduct writes to the SRAM. Sampled on the rising edge of CLK. \overline{BWS}_a controls DQ_a and DP_a , \overline{BWS}_b controls DQ_b and DP_b , \overline{BWS}_c controls DQ_c and DP_c , \overline{BWS}_d controls DQ_d and DP_d .
88	88	\overline{WE}	Input- Synchronous	Write Enable Input, active LOW. Sampled on the rising edge of CLK if \overline{CEN} is active LOW. This signal must be asserted LOW to initiate a write sequence.
85	85	ADV/LD	Input- Synchronous	Advance/Load input used to advance the on-chip address counter or load a new address. When HIGH (and \overline{CEN} is asserted LOW) the internal burst counter is advanced. When LOW, a new address can be loaded into the device for an access. After being deselected, ADV/LD should be driven LOW in order to load a new address.
89	89	CLK	Input-Clock	Clock Input. Used to capture all synchronous inputs to the device. CLK is qualified with \overline{CEN} . CLK is only recognized if \overline{CEN} is active LOW.
98	98	\overline{CE}_1	Input- Synchronous	Chip Enable 1 Input, active LOW. Sampled on the rising edge of CLK. Used in conjunction with CE_2 and \overline{CE}_3 to select/deselect the device.
97	97	CE_2	Input- Synchronous	Chip Enable 2 Input, active HIGH. Sampled on the rising edge of CLK. Used in conjunction with CE_1 and CE_3 to select/deselect the device.
92	92	\overline{CE}_3	Input- Synchronous	Chip Enable 3 Input, active LOW. Sampled on the rising edge of CLK. Used in conjunction with \overline{CE}_1 and CE_2 to select/deselect the device.
86	86	\overline{OE}	Input- Asynchronous	Output Enable, active LOW. Combined with the synchronous logic block inside the device to control the direction of the I/O pins. When LOW, the I/O pins are allowed to behave as outputs. When deasserted HIGH, I/O pins are three-stated, and act as input data pins. \overline{OE} is masked during the data portion of a write sequence, during the first clock when emerging from a deselected state and when the device has been deselected.
87	87	\overline{CEN}	Input- Synchronous	Clock Enable Input, active LOW. When asserted LOW the clock signal is recognized by the SRAM. When deasserted HIGH the clock signal is masked. Since deasserting \overline{CEN} does not deselect the device, \overline{CEN} can be used to extend the previous cycle when required.
(a)58, 59, 62, 63, 68, 69, 72–74, (b)8, 9, 12, 13, 18, 19, 22–24	(a)52, 53, 56–59, 62, 63, (b)68, 69, 72–75, 78, 79, (c)2, 3, 6–9, 12, 13, (d)18, 19, 22–25, 28, 29	DQ_a DQ_b DQ_c DQ_d	I/O- Synchronous	Bidirectional Data I/O lines. As inputs, they feed into an on-chip data register that is triggered by the rising edge of CLK. As outputs, they deliver the data contained in the memory location specified by $A_{[17:0]}$ during the previous clock rise of the read cycle. The direction of the pins is controlled by \overline{OE} and the internal control logic. When \overline{OE} is asserted LOW, the pins can behave as outputs. When HIGH, DQ_a – DQ_d are placed in a three-state condition. The outputs are automatically three-stated during the data portion of a write sequence, during the first clock when emerging from a deselected state, and when the device is deselected, regardless of the state of \overline{OE} .

Pin Definitions (100-Pin TQFP) (continued)

x18 Pin Location	x36 Pin Location	Name	I/O Type	Description
74, 24	51, 80, 1, 30	DP _a DP _b DP _c DP _d	I/O- Synchronous	Bidirectional Data Parity I/O lines. Functionally, these signals are identical to DQ _[31:0] . During write sequences, DP _a is controlled by \overline{BWS}_a , DP _b is controlled by \overline{BWS}_b , DP _c is controlled by \overline{BWS}_c , and DP _d is controlled by \overline{BWS}_d .
31	31	MODE	Input Strap pin	Mode Input. Selects the burst order of the device. Tied HIGH selects the interleaved burst order. Pulled LOW selects the linear burst order. MODE should not change states during operation. When left floating MODE will default HIGH, to an interleaved burst order.
15, 41, 65, 66, 91	15, 41, 65, 66, 91	V _{DD}	Power Supply	Power supply inputs to the core of the device.
4, 11, 20, 27, 54, 61, 70, 77	4, 11, 20, 27, 54, 61, 70, 77	V _{DDQ}	I/O Power Supply	Power supply for the I/O circuitry.
5, 10, 14, 17, 21, 26, 40, 55, 60, 67, 71, 76, 90	5, 10, 14, 17, 21, 26, 40, 55, 60, 67, 71, 76, 90	V _{SS}	Ground	Ground for the device. Should be connected to ground of the system.
		NC	-	No connects. Reserved for address expansion to 512K depths.
38, 39, 42, 43	38, 39, 42, 43	DNU	-	Do Not Use pins. These pins should be left floating.

Pin Definitions (119 BGA)

x18 Pin Location	x36 Pin Location	Name	I/O Type	Description
P4, N4, A2, A3, A5, A6, B3, B5, C2, C3, C5, C6, G4, R2, R6, T2, T3, T5, T6	P4, N4, A2, A3, A5, A6, B3, B5, C2, C3, C5, C6, R2, R6, G4, T3, T4, T5	A0 A1 A	Input-Synchronous	Address Inputs used to select one of the 266,144 address locations. Sampled at the rising edge of the CLK.
L5, G3	L5, G5, G3, L3	\overline{BWS}_a \overline{BWS}_b \overline{BWS}_c \overline{BWS}_d	Input-Synchronous	Byte Write Select Inputs, active LOW. Qualified with \overline{WE} to conduct writes to the SRAM. Sampled on the rising edge of CLK. \overline{BWS}_a controls DQ_a and DP_a , \overline{BWS}_b controls DQ_b and DP_b , \overline{BWS}_c controls DQ_c and DP_c , \overline{BWS}_d controls DQ_d and DP_d .
H4	H4	\overline{WE}	Input-Synchronous	Write Enable Input, active LOW. Sampled on the rising edge of CLK if \overline{CEN} is active LOW. This signal must be asserted LOW to initiate a write sequence.
B4	B4	$\overline{ADV/LD}$	Input-Synchronous	Advance/Load Input used to advance the on-chip address counter or load a new address. When HIGH (and \overline{CEN} is asserted LOW) the internal burst counter is advanced. When LOW, a new address can be loaded into the device for an access. After being deselected, $\overline{ADV/LD}$ should be driven LOW in order to load a new address.
K4	K4	CLK	Input-Clock	Clock Input. Used to capture all synchronous inputs to the device. CLK is qualified with \overline{CEN} . CLK is only recognized if \overline{CEN} is active LOW.
E4	E4	\overline{CE}_1	Input-Synchronous	Chip Enable 1 Input, active LOW. Sampled on the rising edge of CLK. Used in conjunction with CE_2 and \overline{CE}_3 to select/deselect the device.
B2	B2	CE_2	Input-Synchronous	Chip Enable 2 Input, active HIGH. Sampled on the rising edge of CLK. Used in conjunction with \overline{CE}_1 and \overline{CE}_3 to select/deselect the device.
B6	B6	\overline{CE}_3	Input-Synchronous	Chip Enable 3 Input, active LOW. Sampled on the rising edge of CLK. Used in conjunction with \overline{CE}_1 and CE_2 to select/deselect the device.
F4	F4	\overline{OE}	Input-Asynchronous	Output Enable, active LOW. Combined with the synchronous logic block inside the device to control the direction of the I/O pins. When LOW, the I/O pins are allowed to behave as outputs. When deasserted HIGH, I/O pins are three-stated, and act as input data pins. \overline{OE} is masked during the data portion of a write sequence, during the first clock when emerging from a deselected state and when the device has been deselected.
M4	M4	\overline{CEN}	Input-Synchronous	Clock Enable Input, active LOW. When asserted LOW the clock signal is recognized by the SRAM. When deasserted HIGH the clock signal is masked. Since deasserting \overline{CEN} does not deselect the device, \overline{CEN} can be used to extend the previous cycle when required.
(a)P7, N6, L6, K7, H6, G7, F6, E7 (b)N1, M2, L1, K2, H1, G2, E2, D1	(a)P7, N7, N6, M6, L7, L6, K7, K6 (b)D7, E7, E6, F6, G7, G6, H7, H6 (c)D1, E1, E2, F2, G1, G2, H1, H2 (d)P1, N1, N2, M2, L1, L2, K1, K2	DQ_a DQ_b DQ_c DQ_d	I/O-Synchronous	Bidirectional Data I/O lines. As inputs, they feed into an on-chip data register that is triggered by the rising edge of CLK. As outputs, they deliver the data contained in the memory location specified by $A_{[x:0]}$ during the previous clock rise of the read cycle. The direction of the pins is controlled by \overline{OE} and the internal control logic. When \overline{OE} is asserted LOW, the pins can behave as outputs. When HIGH, DQ_a - DQ_d are placed in a three-state condition. The outputs are automatically three-stated during the data portion of a write sequence, during the first clock when emerging from a deselected state, and when the device is deselected, regardless of the state of \overline{OE} .

Pin Definitions (119 BGA) (continued)

x18 Pin Location	x36 Pin Location	Name	I/O Type	Description
D6, P2	P6, D6, D2, P2	DP _a DP _b DP _c DP _d	I/O- Synchronous	Bidirectional Data Parity I/O lines. Functionally, these signals are identical to DQ _a –DQ _d . During write sequences, DP _a is controlled by \overline{BWS}_a , DP _b is controlled by \overline{BWS}_b , DP _c is controlled by \overline{BWS}_c , and DP _d is controlled by \overline{BWS}_d .
R3	R3	MODE	Input Strap Pin	Mode Input. Selects the burst order of the device. Tied HIGH selects the interleaved burst order. Pulled LOW selects the linear burst order. MODE should not change states during operation. When left floating MODE will default HIGH, to an interleaved burst order.
C4, J2, J4, J6, R4	C4, J2, J4, J6, R4	V _{DD}	Power Supply	Power supply inputs to the core of the device.
A1, A7, F1, F7, J1, J7, M1, M7, U1, U7	A1, A7, F1, F7, J1, J7, M1, M7, U1, U7	V _{DDQ}	I/O Power Supply	Power supply for the I/O circuitry.
D3, D5, E3, E5, F3, F5, H3, H5, K3, K5, M3, M5, N3, N5, P3, P5, R5	D3, D5, E3, E5, F3, F5, H3, H5, K3, K5, M3, M5, N3, N5, P3, P5, R5	V _{SS}	Ground	Ground for the device. Should be connected to ground of the system.
T7	T7	ZZ	-	
J3, J5	J3, J5	V _{SS(1)}		These pins have to be tied to a voltage level < V _{il} . They need not be tied to V _{SS} .
U5	U5	TDO	JTAG Serial Output, Synchronous	Serial data-out to the JTAG circuit. Delivers data on the negative edge of TCK.
U3	U3	TDI	JTAG Serial Input, Synchronous	Serial data-in to the JTAG circuit. Sampled on the rising edge of TCK.
U2	U2	TMS	Test Mode Select, Synchronous	This pin controls the Test Access Port state machine. Sampled on the rising edge of TCK.
U4	U4	TCK	JTAG Serial Output, Synchronous	Serial data-out to the JTAG circuit. Delivers data on the negative edge of TCK.
A4, T6, T2	A4, T4, T1	16M, 32M 64M	-	No connects. Reserved for address expansion.
B1, B7, C1, C7, D2, D4, D7, E1, E6, F2, G1, G5, G6, H2, H7, J3, J5, K1, K6, L2, L3, L4, M6, N2, N7, P1, P6, R1, R7	B7, C7, D4, J3, J5, L4, R1, R7, T1	NC	-	No connects.
U6	U6	DNU	-	Do not use pin.

Introduction

Functional Overview

The CY7C1355V25/CY7C1357V25 is a Synchronous Flow-Through Burst NoBL SRAM designed specifically to eliminate wait states during Write-Read transitions. All synchronous inputs pass through input registers controlled by the rising edge of the clock. The clock signal is qualified with the Clock Enable input signal (\overline{CEN}). If \overline{CEN} is HIGH, the clock signal is not recognized and all internal states are maintained. All synchronous operations are qualified with \overline{CEN} . Maximum access delay from the clock rise (t_{CDV}) is 6.5 ns (133-MHz device).

Accesses can be initiated by asserting all three Chip Enables (\overline{CE}_1 , CE_2 , \overline{CE}_3) active at the rising edge of the clock. If Clock Enable (\overline{CEN}) is active LOW and ADV/LD is asserted LOW, the address presented to the device will be latched. The access can either be a Read or Write operation, depending on the status of the Write Enable (\overline{WE}). Byte Write Selects can be used to conduct byte write operations.

Write operations are qualified by the Write Enable (\overline{WE}). All writes are simplified with on-chip synchronous self-timed write circuitry.

Three synchronous Chip Enables (\overline{CE}_1 , CE_2 , \overline{CE}_3) and an asynchronous Output Enable (\overline{OE}) simplify depth expansion. All operations (Reads, Writes, and Deselects) are pipelined. ADV/LD should be driven LOW once the device has been deselected in order to load a new address for the next operation.

Single Read Accesses

A read access is initiated when the following conditions are satisfied at clock rise: (1) \overline{CEN} is asserted LOW, (2) \overline{CE}_1 , CE_2 , and \overline{CE}_3 are ALL asserted active, (3) the Write Enable input signal \overline{WE} is deasserted HIGH, and 4) ADV/LD is asserted LOW. The address presented to the address inputs is latched into the Address Register and presented to the memory core and control logic. The control logic determines that a read access is in progress and allows the requested data to propagate to the output buffers. The data is available within 6.5 ns (133-MHz device) provided \overline{OE} is active LOW. After the first clock of the read access the output buffers are controlled by \overline{OE} and the internal control logic. \overline{OE} must be driven LOW in order for the device to drive out the requested data. On the subsequent clock, another operation (Read/Write/Deselect) can be initiated. When the SRAM is deselected at clock rise by one of the chip enable signals, its output will be three-stated immediately.

Burst Read Accesses

The CY7C1355V25/CY7C1357V25 has an on-chip burst counter that allows the user the ability to supply a single address and conduct up to four Reads without reasserting the address inputs. ADV/LD must be driven LOW in order to load a new address into the SRAM, as described in the Single Read Access section above. The sequence of the burst counter is determined by the MODE input signal. A LOW input on MODE selects a linear burst mode, a HIGH selects an interleaved

burst sequence. Both burst counters use A0 and A1 in the burst sequence, and will wrap-around when incremented sufficiently. A HIGH input on ADV/LD will increment the internal burst counter regardless of the state of chip enable inputs or \overline{WE} . \overline{WE} is latched at the beginning of a burst cycle. Therefore, the type of access (Read or Write) is maintained throughout the burst sequence.

Single Write Accesses

Write access are initiated when the following conditions are satisfied at clock rise: (1) \overline{CEN} is asserted LOW, (2) \overline{CE}_1 , CE_2 , and \overline{CE}_3 are ALL asserted active, and (3) the write signal \overline{WE} is asserted LOW. The address presented is loaded into the Address Register. The write signals are latched into the Control Logic block. The data lines are automatically three-stated regardless of the state of the \overline{OE} input signal. This allows the external logic to present the data on DQ and DP.

On the next clock rise the data presented to DQ and DP (or a subset for byte write operations, see Write Cycle Description table for details) inputs is latched into the device and the write is complete. Additional accesses (Read/Write/Deselect) can be initiated on this cycle.

The data written during the Write operation is controlled by Byte Write Select signals. The CY7C1355V25/CY7C1357V25 provide byte write capability that is described in the Write Cycle Description table. Asserting the Write Enable input (\overline{WE}) with the selected Byte Write Select input will selectively write to only the desired bytes. Bytes not selected during a byte write operation will remain unaltered. A Synchronous self-timed write mechanism has been provided to simplify the write operations. Byte write capability has been included in order to greatly simplify Read/Modify/Write sequences, which can be reduced to simple byte write operations.

Because the CY7C1355V25/CY7C1357V25 are common I/O devices, data should not be driven into the device while the outputs are active. The Output Enable (\overline{OE}) can be deasserted HIGH before presenting data to the DQ and DP inputs. Doing so will three-state the output drivers. As a safety precaution, DQ and DP are automatically three-stated during the data portion of a write cycle, regardless of the state of \overline{OE} .

Burst Write Accesses

The CY7C1355V25/CY7C1357V25 has an on-chip burst counter that allows the user the ability to supply a single address and conduct up to four Write operations without reasserting the address inputs. ADV/LD must be driven LOW in order to load the initial address, as described in the Single Write Access section above. When ADV/LD is driven HIGH on the subsequent clock rise, the chip enables (\overline{CE}_1 , CE_2 , and \overline{CE}_3) and \overline{WE} inputs are ignored and the burst counter is incremented. The correct $\overline{BWS}_{a,b,c,d}/\overline{BWS}_{a,b}$ inputs must be driven in each cycle of the burst write in order to write the correct bytes of data.

Cycle Description Truth Table^[1, 2, 3, 4, 5, 6]

Operation	Address used	\overline{CE}	\overline{CEN}	ADV/ LD	\overline{WE}	\overline{BWS}_x	CLK	Comments
Deselected	External	1	0	0	X	X	L-H	I/Os three-state following next recognized clock.
Suspend	-	X	1	X	X	X	L-H	Clock ignored, all operations suspended.
Begin Read	External	0	0	0	1	X	L-H	Address latched.
Begin Write	External	0	0	0	0	Valid	L-H	Address latched, data presented two valid clocks later.
Burst READ Operation	Internal	X	0	1	X	X	L-H	Burst Read operation. Previous access was a Read operation. Addresses incremented internally in conjunction with the state of MODE.
Burst WRITE Operation	Internal	X	0	1	X	Valid	L-H	Burst Write operation. Previous access was a Write operation. Addresses incremented internally in conjunction with the state of MODE. Bytes written are determined by $\overline{BWS}_{a,b,c,d} / \overline{BWS}_{a,b}$.

Interleaved Burst Sequence

First Address	Second Address	Third Address	Fourth Address
A[1:0]	A[1:0]	A[1:0]	A[1:0]
00	01	10	11
01	00	11	10
10	11	00	01
11	10	01	00

Linear Burst Sequence

First Address	Second Address	Third Address	Fourth Address
A[1:0]	A[1:0]	A[1:0]	A[1:0]
00	01	10	11
01	10	11	00
10	11	00	01
11	00	01	10

Notes:

- X = "don't care," 1 = Logic HIGH, 0 = Logic LOW, \overline{CE} stands for ALL Chip Enables. $\overline{CE} = 0$ stands for ALL Chip Enables are active.
- Write is defined by \overline{WE} and \overline{BWS}_x . $\overline{BWS}_x = \text{Valid}$ signifies that the desired byte write selects are asserted. See Write Cycle Description table for details.
- The \overline{DQ} and \overline{DP} pins are controlled by the current cycle and the \overline{OE} signal.
- $\overline{CEN} = 1$ inserts wait states.
- Device will power-up deselected and the I/Os in a three-state condition, regardless of \overline{OE} .
- \overline{OE} assumed LOW.

Write Cycle Description^[1]

Function (CY7C1355V25)	\overline{WE}	\overline{BWS}_d	\overline{BWS}_c	\overline{BWS}_b	\overline{BWS}_a
Read	1	X	X	X	X
Write – No Bytes Written	0	1	1	1	1
Write Byte 0 – (DQ _a and DP _a)	0	1	1	1	0
Write Byte 1 – (DQ _b and DP _b)	0	1	1	0	1
Write Bytes 1, 0	0	1	1	0	0
Write Byte 2 – (DQ _c and DP _c)	0	1	0	1	1
Write Bytes 2, 0	0	1	0	1	0
Write Bytes 2, 1	0	1	0	0	1
Write Bytes 2, 1, 0	0	1	0	0	0
Write Byte 3 – (DQ _b and DP _d)	0	0	1	1	1
Write Bytes 3, 0	0	0	1	1	0
Write Bytes 3, 1	0	0	1	0	1
Write Bytes 3, 1, 0	0	0	1	0	0
Write Bytes 3, 2	0	0	0	1	1
Write Bytes 3, 2, 0	0	0	0	1	0
Write Bytes 3, 2, 1	0	0	0	0	1
Write All Bytes	0	0	0	0	0

Function (CY7C1357V25)	\overline{WE}	\overline{BWS}_b	\overline{BWS}_a
Read	1	x	x
Write – No Bytes Written	0	1	1
Write Byte 0 – (DQ _a and DP _a)	0	1	0
Write Byte 1 – (DQ _b and DP _b)	0	0	1
Write Both Bytes	0	0	0

IEEE 1149.1 Serial Boundary Scan (JTAG)

The CY7C1355V25/57V25 incorporates a serial boundary scan Test Access Port (TAP) in the BGA package only. The TQFP package does not offer this functionality. This port operates in accordance with IEEE Standard 1149.1-1900, but does not have the set of functions required for full 1149.1 compliance. These functions from the IEEE specification are excluded because their inclusion places an added delay in the critical speed path of the SRAM. Note that the TAP controller functions in a manner that does not conflict with the operation of other devices using 1149.1 fully compliant TAPs. The TAP operates using JEDEC standard 2.5V I/O logic levels.

Disabling the JTAG Feature

It is possible to operate the SRAM without using the JTAG feature. To disable the TAP controller, TCK must be tied LOW (V_{SS}) to prevent clocking of the device. TDI and TMS are internally pulled up and may be unconnected. They may alternately be connected to V_{DD} through a pull-up resistor. TDO should be left unconnected. Upon power-up, the device will come up in a reset state which will not interfere with the operation of the device.

Test Access Port (TAP) - Test Clock

The test clock is used only with the TAP controller. All inputs are captured on the rising edge of TCK. All outputs are driven from the falling edge of TCK.

Test Mode Select

The TMS input is used to give commands to the TAP controller and is sampled on the rising edge of TCK. It is allowable to leave this pin unconnected if the TAP is not used. The pin is pulled up internally, resulting in a logic HIGH level.

Test Data In (TDI)

The TDI pin is used to serially input information into the registers and can be connected to the input of any of the registers. The register between TDI and TDO is chosen by the instruction that is loaded into the TAP instruction register. For information on loading the instruction register, see the TAP Controller State Diagram. TDI is internally pulled up and can be unconnected if the TAP is unused in an application. TDI is connected to the Most Significant Bit (MSB) on any register.

Test Data Out (TDO)

The TDO output pin is used to serially clock data-out from the registers. The output is active depending upon the current state of the TAP state machine (See TAP Controller State diagram). The output changes on the falling edge of TCK. TDO is connected to the Least Significant Bit (LSB) of any register.

Performing a TAP Reset

A Reset is performed by forcing TMS HIGH (V_{DD}) for five rising edges of TCK. This RESET does not affect the operation of the SRAM and may be performed while the SRAM is operating. At power-up, the TAP is reset internally to ensure that TDO comes up in a High-Z state.

TAP Registers

Registers are connected between the TDI and TDO pins and allow data to be scanned into and out of the SRAM test circuitry. Only one register can be selected at a time through the

instruction registers. Data is serially loaded into the TDI pin on the rising edge of TCK. Data is output on the TDO pin on the falling edge of TCK.

Instruction Register

Three-bit instructions can be serially loaded into the instruction register. This register is loaded when it is placed between the TDI and TDO pins as shown in the TAP Controller Block diagram. Upon power-up, the instruction register is loaded with the IDCODE instruction. It is also loaded with the IDCODE instruction if the controller is placed in a reset state as described in the previous section.

When the TAP controller is in the CaptureIR state, the two least significant bits are loaded with a binary "01" pattern to allow for fault isolation of the board level serial test path.

Bypass Register

To save time when serially shifting data through registers, it is sometimes advantageous to skip certain states. The bypass register is a single-bit register that can be placed between TDI and TDO pins. This allows data to be shifted through the SRAM with minimal delay. The bypass register is set LOW (V_{SS}) when the BYPASS instruction is executed.

Boundary Scan Register

The boundary scan register is connected to all the input and output pins on the SRAM. Several no connect (NC) pins are also included in the scan register to reserve pins for higher density devices. The x36 configuration has a xx-bit-long register, and the x18 configuration has a yy-bit-long register.

The boundary scan register is loaded with the contents of the RAM Input and Output ring when the TAP controller is in the Capture-DR state and is then placed between the TDI and TDO pins when the controller is moved to the Shift-DR state. The EXTEST, SAMPLE/PRELOAD and SAMPLE Z instructions can be used to capture the contents of the Input and Output ring.

The Boundary Scan Order tables show the order in which the bits are connected. Each bit corresponds to one of the bumps on the SRAM package. The MSB of the register is connected to TDI, and the LSB is connected to TDO.

Identification (ID) Register

The ID register is loaded with a vendor-specific, 32-bit code during the Capture-DR state when the IDCODE command is loaded in the instruction register. The IDCODE is hardwired into the SRAM and can be shifted out when the TAP controller is in the Shift-DR state. The ID register has a vendor code and other information described in the Identification Register Definitions table.

TAP Instruction Set

Eight different instructions are possible with the three-bit instruction register. All combinations are listed in the Instruction Code table. Three of these instructions are listed as RESERVED and should not be used. The other five instructions are described in detail below.

The TAP controller used in this SRAM is not fully compliant to the 1149.1 convention because some of the mandatory 1149.1 instructions are not fully implemented. The TAP controller cannot be used to load address, data, or control signals into the SRAM and cannot preload the Input or Output buffers. The

SRAM does not implement the 1149.1 commands EXTEST or INTEST or the PRELOAD portion of SAMPLE / PRELOAD; rather it performs a capture of the Inputs and Output ring when these instructions are executed.

Instructions are loaded into the TAP controller during the Shift-IR state when the instruction register is placed between TDI and TDO. During this state, instructions are shifted through the instruction register through the TDI and TDO pins. To execute the instruction once it is shifted in, the TAP controller needs to be moved into the Update-IR state.

EXTEST

EXTEST is a mandatory 1149.1 instruction which is to be executed whenever the instruction register is loaded with all 0s. EXTEST is not implemented in the TAP controller, and therefore this device is not compliant to the 1149.1 standard.

The TAP controller does not recognize an all-0 instruction. When an EXTEST instruction is loaded into the instruction register, the SRAM responds as if a SAMPLE / PRELOAD instruction has been loaded. There is one difference between the two instructions. Unlike the SAMPLE / PRELOAD instruction, EXTEST places the SRAM outputs in a High-Z state.

IDCODE

The IDCODE instruction causes a vendor-specific, 32-bit code to be loaded into the instruction register. It also places the instruction register between the TDI and TDO pins and allows the IDCODE to be shifted out of the device when the TAP controller enters the Shift-DR state. The IDCODE instruction is loaded into the instruction register upon power-up or whenever the TAP controller is given a test logic reset state.

SAMPLE Z

The SAMPLE Z instruction causes the boundary scan register to be connected between the TDI and TDO pins when the TAP controller is in a Shift-DR state. It also places all SRAM outputs into a High-Z state.

SAMPLE / PRELOAD

SAMPLE / PRELOAD is a 1149.1 mandatory instruction. The PRELOAD portion of this instruction is not implemented, so the TAP controller is not fully 1149.1 compliant.

When the SAMPLE / PRELOAD instructions are loaded into the instruction register and the TAP controller is in the Capture-DR state, a snapshot of data on the inputs and output pins is captured in the boundary scan register.

The user must be aware that the TAP controller clock can only operate at a frequency up to 10 MHz, while the SRAM clock operates more than an order of magnitude faster. Because there is a large difference in the clock frequencies, it is possible that during the Capture-DR state, an input or output will undergo a transition. The TAP may then try to capture a signal while in transition (metastable state). This will not harm the device, but there is no guarantee as to the value that will be captured. Repeatable results may not be possible.

To guarantee that the boundary scan register will capture the correct value of a signal, the SRAM signal must be stabilized long enough to meet the TAP controller's capture set-up plus hold times (t_{CS} and t_{CH}). The SRAM clock input might not be captured correctly if there is no way in a design to stop (or slow) the clock during a SAMPLE / PRELOAD instruction. If this is an issue, it is still possible to capture all other signals and simply ignore the value of the CK and CK# captured in the boundary scan register.

Once the data is captured, it is possible to shift out the data by putting the TAP into the Shift-DR state. This places the boundary scan register between the TDI and TDO pins.

Note that since the PRELOAD part of the command is not implemented, putting the TAP into the Update to the Update-DR state while performing a SAMPLE / PRELOAD instruction will have the same effect as the Pause-DR command.

Bypass

When the BYPASS instruction is loaded in the instruction register and the TAP is placed in a Shift-DR state, the bypass register is placed between the TDI and TDO pins. The advantage of the BYPASS instruction is that it shortens the boundary scan path when multiple devices are connected together on a board.

Reserved

These instructions are not implemented but are reserved for future use. Do not use these instructions.

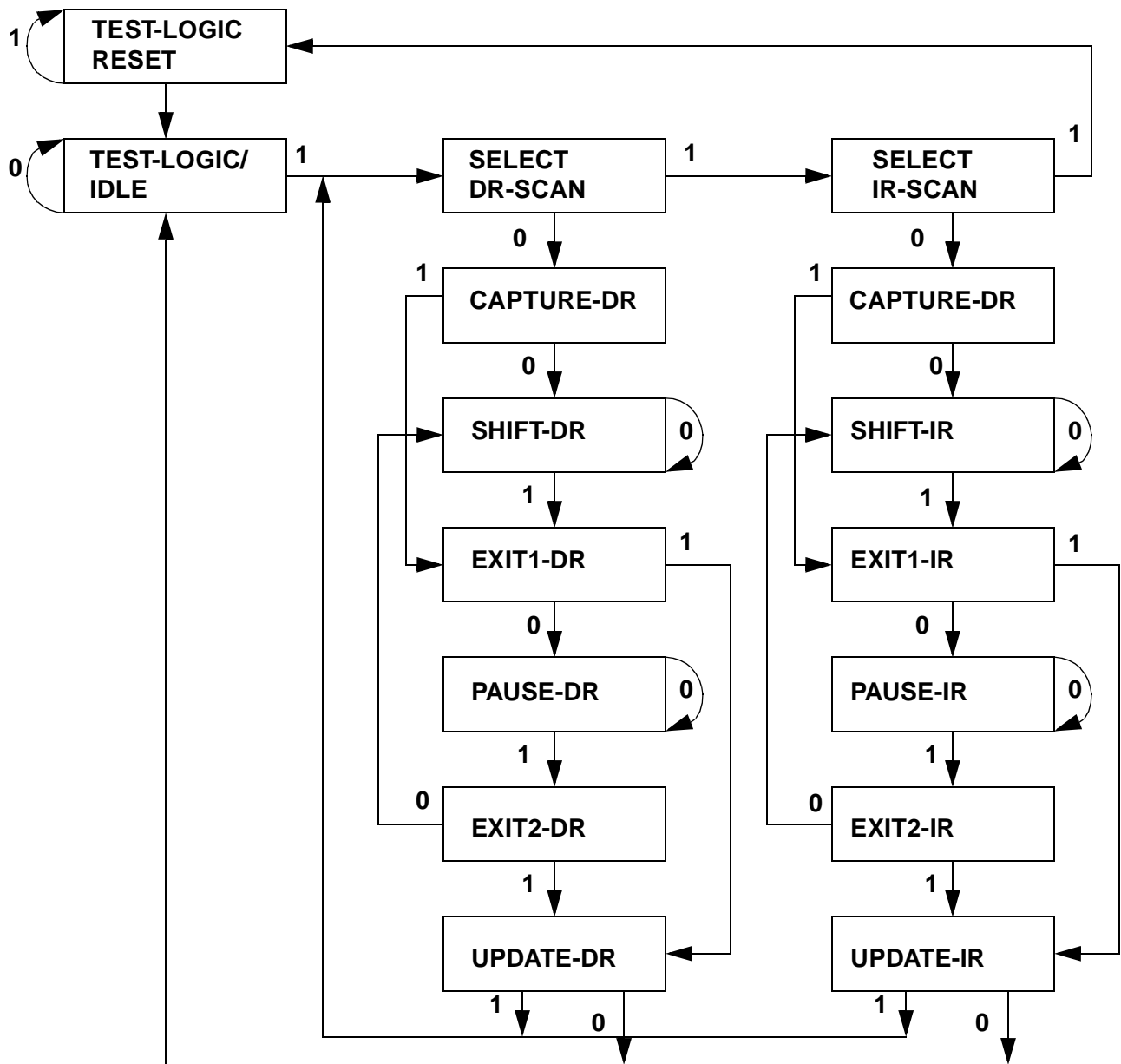
TAP Controller State Diagram

Note: The 0/1 next to each state represents the value at TMS at the rising edge of TCK.

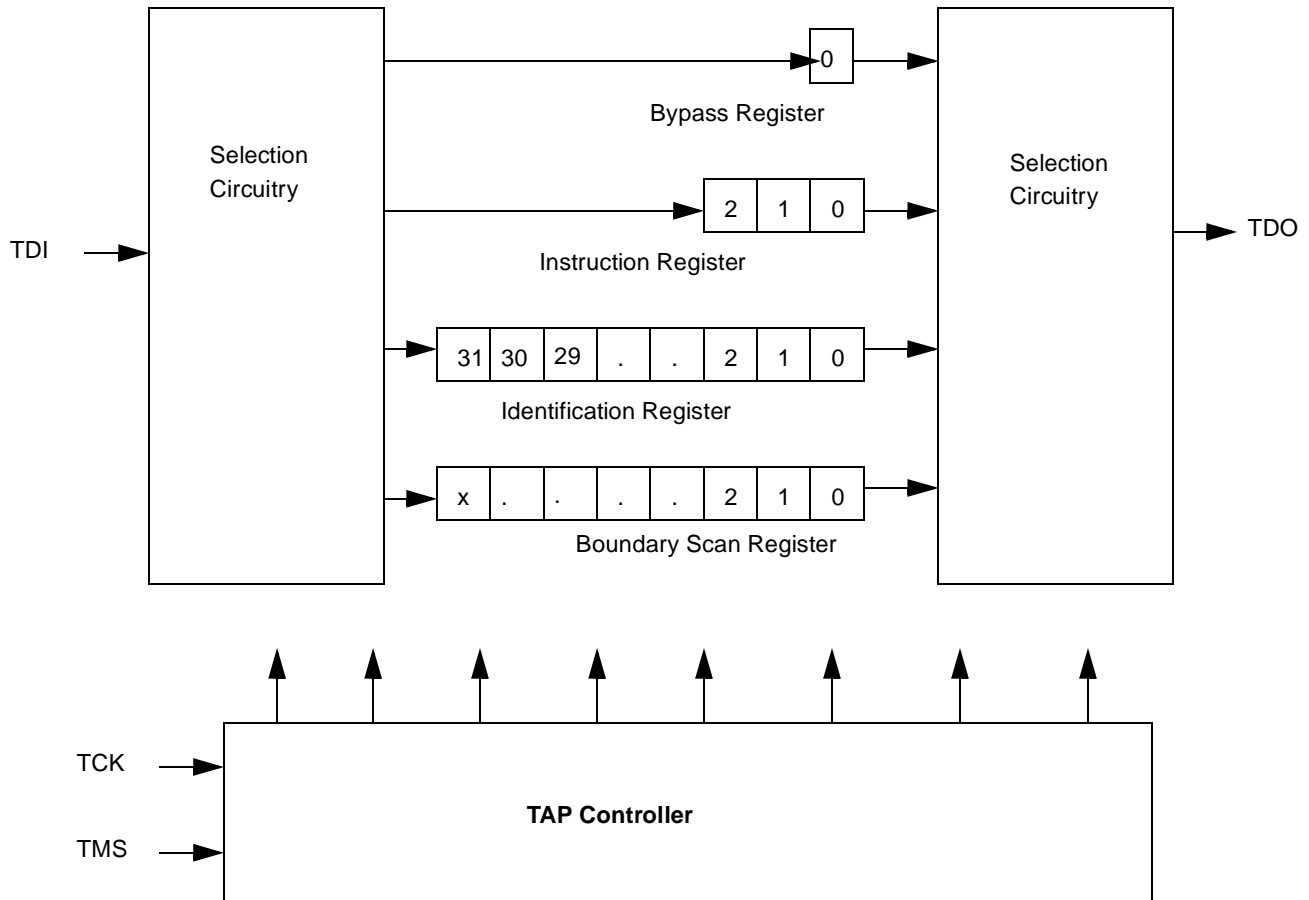
TAP Controller Block Diagram

TAP Electrical Characteristics Over the Operating Range^[7, 8]

Parameter	Description	Test Conditions	Min.	Max.	Unit
V _{OH1}	Output HIGH Voltage	I _{OH} = -2.0 mA	1.7		V
V _{OH2}	Output HIGH Voltage	I _{OH} = -100 μA	2.1		V
V _{OL1}	Output LOW Voltage	I _{OL} = 2.0 mA		0.7	V
V _{OL2}	Output LOW Voltage	I _{OL} = 100 μA		0.2	V
V _{IH}	Input HIGH Voltage		1.7	V _{DD} +0.3	V
V _{IL}	Input LOW Voltage		-0.3	0.7	V
I _X	Input Load Current	GND ≤ V _I ≤ V _{DDQ}	-5	5	μA

Notes:

- All Voltage referenced to Ground.
- Overshoot: V_{IH}(AC) ≤ V_{DD}+1.5V for t_s ≤ t_{TCYC}/2, Undershoot: V_{IL}(AC) ≤ 0.5V for t_s ≤ t_{TCYC}/2, Power-up: V_{IH} < 2.6V and V_{DD} < 2.4V and V_{DDQ} < 1.4V for t < 200 ms.

TAP AC Switching Characteristics Over the Operating Range^[9, 10]

Parameter	Description	Min.	Max	Unit
t_{TCYC}	TCK Clock Cycle Time	100		ns
t_{TF}	TCK Clock Frequency		10	MHz
t_{TH}	TCK Clock HIGH	40		ns
t_{TL}	TCK Clock LOW	40		ns
Set-up Times				
t_{TMSS}	TMS Set-up to TCK Clock Rise	10		ns
t_{TDIS}	TDI Set-up to TCK Clock Rise	10		ns
t_{CS}	Capture Set-up to TCK Rise	10		ns
Hold Times				
t_{TMSH}	TMS Hold after TCK Clock Rise	10		ns
t_{TDIH}	TDI Hold after Clock Rise	10		ns
t_{CH}	Capture Hold after Clock Rise	10		ns
Output Times				
t_{TDOV}	TCK Clock LOW to TDO Valid		20	ns
t_{TDOX}	TCK Clock LOW to TDO Invalid	0		ns

Notes:

9. t_{CS} and t_{CH} refer to the set-up and hold time requirements of latching data from the boundary scan register.
 10. Test conditions are specified using the load in TAP AC test conditions. $t_R/t_F = 1$ ns.

TAP Timing and Test Conditions

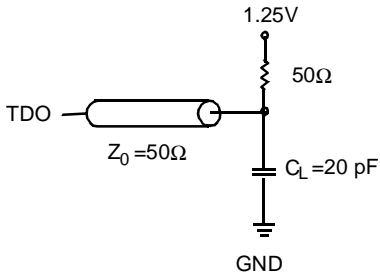

(a)

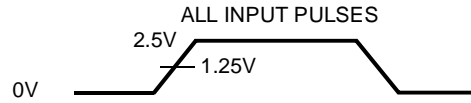

(b)

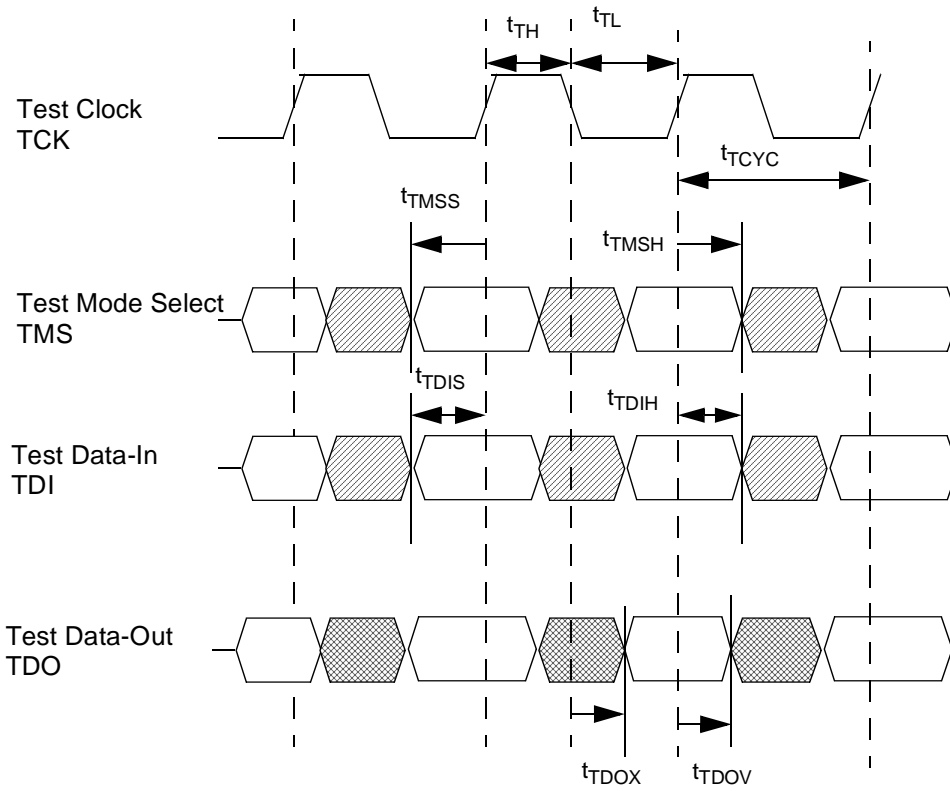

Identification Register Definitions

Instruction Field	Value	Description
Revision Number (31:28)	TBD	Reserved for version number.
Device Depth (27:23)	TBD	Defines depth of SRAM.
Device Width (22:18)	TBD	Defines with of the SRAM.
Cypress Device ID (17:12)	TBD	Reserved for future use.
Cypress JEDEC ID (11:1)	TBD	Allows unique identification of SRAM vendor.
ID Register Presence (0)	TBD	Indicate the presence of an ID register.

Scan Register Sizes

Register Name	Bit Size
Instruction	3
Bypass	1
ID	32
Boundary Scan	TBD

Identification Codes

Instruction	Code	Description
EXTEST	000	Captures the Input/Output ring contents. Places the boundary scan register between the TDI and TDO. Forces all SRAM outputs to High-Z state. This instruction is not 1149.1 compliant.
IDCODE	001	Loads the ID register with the vendor ID code and places the register between TDI and TDO. This operation does not affect SRAM operation.
SAMPLE Z	010	Captures the Input/Output contents. Places the boundary scan register between TDI and TDO. Forces all SRAM output drivers to a High-Z state.
RESERVED	011	Do Not Use: This instruction is reserved for future use.
SAMPLE/PRELOAD	100	Captures the Input/Output ring contents. Places the boundary scan register between TDI and TDO. Does not affect the SRAM operation. This instruction does not implement 1149.1 preload function and is therefore not 1149.1 compliant.
RESERVED	101	Do Not Use: This instruction is reserved for future use.
RESERVED	110	Do Not Use: This instruction is reserved for future use.
BYPASS	111	Places the bypass register between TDI and TDO. This operation does not affect SRAM operation.

Boundary Scan Order

Bit #	Signal Name	Bump ID	Bit #	Signal Name	Bump ID
1	TBD	TBD	36	TBD	TBD
2	TBD	TBD	37	TBD	TBD
3	TBD	TBD	38	TBD	TBD
4	TBD	TBD	39	TBD	TBD
5	TBD	TBD	40	TBD	TBD
6	TBD	TBD	41	TBD	TBD
7	TBD	TBD	42	TBD	TBD
8	TBD	TBD	43	TBD	TBD
9	TBD	TBD	44	TBD	TBD
10	TBD	TBD	45	TBD	TBD
11	TBD	TBD	46	TBD	TBD
12	TBD	TBD	47	TBD	TBD
13	TBD	TBD	48	TBD	TBD
14	TBD	TBD	49	TBD	TBD
15	TBD	TBD	50	TBD	TBD
16	TBD	TBD	51	TBD	TBD
17	TBD	TBD	52	TBD	TBD
18	TBD	TBD	53	TBD	TBD
19	TBD	TBD	54	TBD	TBD
20	TBD	TBD	55	TBD	TBD
21	TBD	TBD	56	TBD	TBD
22	TBD	TBD	57	TBD	TBD
23	TBD	TBD	58	TBD	TBD
24	TBD	TBD	59	TBD	TBD
25	TBD	TBD	60	TBD	TBD
26	TBD	TBD	61	TBD	TBD
27	TBD	TBD	62	TBD	TBD
28	TBD	TBD	63	TBD	TBD
29	TBD	TBD	64	TBD	TBD
30	TBD	TBD	65	TBD	TBD
31	TBD	TBD	66	TBD	TBD
32	TBD	TBD	67	TBD	TBD
33	TBD	TBD	68	TBD	TBD
34	TBD	TBD	69	TBD	TBD
35	TBD	TBD	70	TBD	TBD

Boundary Scan Order

Bit #	Signal Name	Bump ID	Bit #	Signal Name	Bump ID
71	TBD	TBD		TBD	TBD
72	TBD	TBD		TBD	TBD
73	TBD	TBD		TBD	TBD
74	TBD	TBD		TBD	TBD
75	TBD	TBD		TBD	TBD
76	TBD	TBD		TBD	TBD
77	TBD	TBD		TBD	TBD
78	TBD	TBD		TBD	TBD
79	TBD	TBD		TBD	TBD
80	TBD	TBD		TBD	TBD
81	TBD	TBD		TBD	TBD
82	TBD	TBD		TBD	TBD
83	TBD	TBD		TBD	TBD
84	TBD	TBD		TBD	TBD
85	TBD	TBD		TBD	TBD
86	TBD	TBD		TBD	TBD
87	TBD	TBD		TBD	TBD
88	TBD	TBD		TBD	TBD
89	TBD	TBD		TBD	TBD
90	TBD	TBD		TBD	TBD
91	TBD	TBD		TBD	TBD
92	TBD	TBD		TBD	TBD
93	TBD	TBD		TBD	TBD
94	TBD	TBD		TBD	TBD
95	TBD	TBD		TBD	TBD
96	TBD	TBD		TBD	TBD
97	TBD	TBD		TBD	TBD
98	TBD	TBD		TBD	TBD
99	TBD	TBD		TBD	TBD



Maximum Ratings

(Above which the useful life may be impaired. For user guidelines, not tested.)

- Storage Temperature -65°C to +150°C
- Ambient Temperature with Power Applied..... -55°C to +125°C
- Supply Voltage on V_{DD} Relative to GND -0.5V to +3.6V
- DC Voltage Applied to Outputs in High Z State^[12]..... -0.5V to V_{DDQ} + 0.5V
- DC Input Voltage^[12]..... -0.5V to V_{DDQ} + 0.5V

- Current into Outputs (LOW)..... 20 mA
- Static Discharge Voltage >2001V (per MIL-STD-883, Method 3015)
- Latch-Up Current..... >200 mA

Operating Range

Range	Ambient Temperature ^[11]	V _{DD} /V _{DDQ}
Com'l	0°C to +70°C	2.5V ± 5%

Electrical Characteristics Over the Operating Range

Parameter	Description	Test Conditions	Min.	Max.	Unit
V _{DD}	Power Supply Voltage		2.375	2.625	V
V _{DDQ}	I/O Supply Voltage		2.375	2.625	V
V _{OH}	Output HIGH Voltage	V _{DD} = Min., I _{OH} = -1.0 mA ^[13]	2.0		V
V _{OL}	Output LOW Voltage	V _{DD} = Min., I _{OL} = 1.0 mA ^[13]		0.2	V
V _{IH}	Input HIGH Voltage		1.7	V _{DD} + 0.3V	V
V _{IL}	Input LOW Voltage ^[12]		-0.3	0.7	V
I _X	Input Load Current	GND ≤ V _I ≤ V _{DDQ}	-5	5	μA
	Input Current of MODE		-30	30	μA
I _{OZ}	Output Leakage Current	GND ≤ V _I ≤ V _{DDQ} , Output Disabled	-5	5	μA
I _{DD}	V _{DD} Operating Supply	V _{DD} = Max., I _{OUT} = 0 mA, f = f _{MAX} = 1/t _{CYC}	7.5-ns cycle, 133 MHz	300	mA
			8.5-ns cycle, 117 MHz	280	mA
			10-ns cycle, 100 MHz	250	mA
			12-ns cycle, 80 MHz	200	mA
I _{SB1}	Automatic CE Power-Down Current—TTL Inputs	Max. V _{DD} , Device Deselected, V _{IN} ≥ V _{IH} or V _{IN} ≤ V _{IL} , f = f _{MAX} = 1/t _{CYC}	7.5-ns cycle, 133 MHz	90	mA
			8.5-ns cycle, 117 MHz	80	mA
			10-ns cycle, 100 MHz	70	mA
			12-ns cycle, 80 MHz	65	mA
I _{SB2}	Automatic CE Power-Down Current—CMOS Inputs	Max. V _{DD} , Device Deselected, V _{IN} ≤ 0.3V or V _{IN} ≥ V _{DDQ} - 0.3V, f = 0		10	mA
I _{SB3}	Automatic CE Power-Down Current—CMOS Inputs	Max. V _{DD} , Device Deselected, or V _{IN} ≤ 0.3V or V _{IN} ≥ V _{DDQ} - 0.3V, f = f _{MAX} = 1/t _{CYC}	7.5-ns cycle, 133 MHz	45	mA
			8.5-ns cycle, 117 MHz	40	mA
			10-ns cycle, 100 MHz	35	mA
			12-ns cycle, 80 MHz	30	mA
I _{SB4}	Automatic CE Power-Down Current—TTL Inputs	Max. V _{DD} , Device Deselected, V _{IN} ≥ V _{IH} or V _{IN} ≤ V _{IL} , f = 0		25	mA

Notes:

- 11. T_A is the case temperature.
- 12. Minimum voltage equals -2.0V for pulse durations of less than 20 ns.
- 13. The load used for V_{OH} and V_{OL} testing is shown in figure (b) of the AC Test Loads.

Capacitance^[15]

Parameter	Description	Test Conditions	Max.	Unit
C_{IN}	Input Capacitance	$T_A = 25^\circ\text{C}$, $f = 1\text{ MHz}$, $V_{DD} = V_{DDQ} = 2.5\text{V}$	4	pF
C_{CLK}	Clock Input Capacitance		4	pF
$C_{I/O}$	Input/Output Capacitance		4	pF

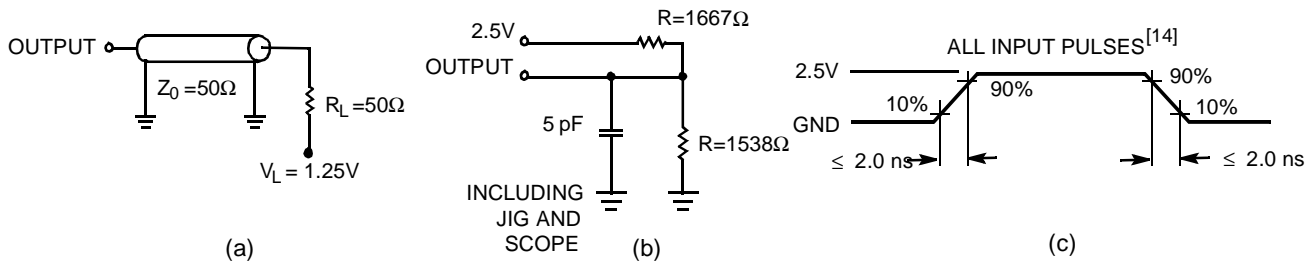
AC Test Loads and Waveforms

Thermal Resistance

Description	Test Conditions	Symbol	TQFP Typ.	Units	Notes
Thermal Resistance (Junction to Ambient)	Still Air, soldered on a 4.25 x 1.125 inch, 4-layer printed circuit board.	Θ_{JA}	TBD	$^\circ\text{C/W}$	15
Thermal Resistance (Junction to Case)		Θ_{JC}	TBD	$^\circ\text{C/W}$	15

Notes:

14. Input waveform should have a slew rate of $\geq 1\text{ V/ns}$.
 15. Tested initially and after any design or process change that may affect these parameters.

Switching Characteristics Over the Operating Range^[16]

Parameter	Description	-133		-117		100		80		Unit
		Min.	Max.	Min.	Max.	Min.	Max.	Min.	Max.	
Clock										
t _{CYC}	Clock Cycle Time	7.5		8.5		10.0		15.0		ns
F _{MAX}	Maximum Operating Frequency		133		117		100		80	MHz
t _{CH}	Clock HIGH	1.9		1.9		1.9		4.0		ns
t _{CL}	Clock LOW	1.9		1.9		1.9		4.0		ns
Output Times										
t _{CDV}	Data Output Valid After CLK Rise		6.5		7.5		8.5		10.0	ns
t _{EOV}	\overline{OE} LOW to Output Valid ^[15, 17]		4.0		4.2		5.0		5.0	ns
t _{DOH}	Data Output Hold After CLK Rise	1.5		1.5		1.5		1.5		ns
t _{CHZ}	Clock to High-Z ^[18, 19, 17]	1.5	4.0	1.5	4.2	1.5	5.0	1.5	5.0	ns
t _{CLZ}	Clock to Low-Z ^[18, 19, 17]	3		3		3		3		ns
t _{EOHZ}	\overline{OE} HIGH to Output High-Z ^[18, 19, 17]		4.0		4.2		5.0		5.0	ns
t _{EOLZ}	\overline{OE} LOW to Output Low-Z ^[18, 19, 17]	0		0		0		0		ns
Set-up Times										
t _{AS}	Address Set-Up Before CLK Rise	1.5		2.0		2.0		2.0		ns
t _{DS}	Data Input Set-Up Before CLK Rise	1.5		2.0		2.0		2.0		ns
t _{CENS}	\overline{CEN} Set-Up Before CLK Rise	1.5		2.0		2.0		2.0		ns
t _{WES}	\overline{WE} , \overline{BWS}_x Set-Up Before CLK Rise	1.5		2.0		2.0		2.0		ns
t _{ALS}	$\overline{ADV}/\overline{LD}$ Set-Up Before CLK Rise	1.5		2.0		2.0		2.0		ns
t _{CES}	Chip Select Set-Up	1.5		2.0		2.0		2.0		ns
Hold Times										
t _{AH}	Address Hold After CLK Rise	0.5		0.5		0.5		0.5		ns
t _{DH}	Data Input Hold After CLK Rise	0.5		0.5		0.5		0.5		ns
t _{CENH}	\overline{CEN} Hold After CLK Rise	0.5		0.5		0.5		0.5		ns
t _{WEH}	\overline{WE} , \overline{BW}_x Hold After CLK Rise	0.5		0.5		0.5		0.5		ns
t _{ALH}	$\overline{ADV}/\overline{LD}$ Hold after CLK Rise	0.5		0.5		0.5		0.5		ns
t _{CEH}	Chip Select Hold After CLK Rise	0.5		0.5		0.5		0.5		ns

Shaded areas contain advance information.

Notes:

- Unless otherwise noted, test conditions assume signal transition time of 2.5 ns or less, timing reference levels of 1.25V, input pulse levels of 0 to 2.5V, and output loading of the specified I_{OL}/I_{OH} and load capacitance. Shown in (a), (b) and (c) of AC test loads.
- This parameter is sampled and not 100% tested.
- t_{CHZ}, t_{CLZ}, t_{EOV}, t_{EOLZ}, and t_{EOHZ} are specified with A/C test conditions shown in part (a) of AC Test Loads. Transition is measured ± 200 mV from steady-state voltage.
- At any given voltage and temperature, t_{EOHZ} is less than t_{EOLZ} and t_{CHZ} is less than t_{CLZ} to eliminate bus contention between SRAMs when sharing the same data bus. These specifications do not imply a bus contention condition, but reflect parameters guaranteed over worst case user conditions. Device is designed to achieve High-Z prior to Low-Z under the same system conditions.

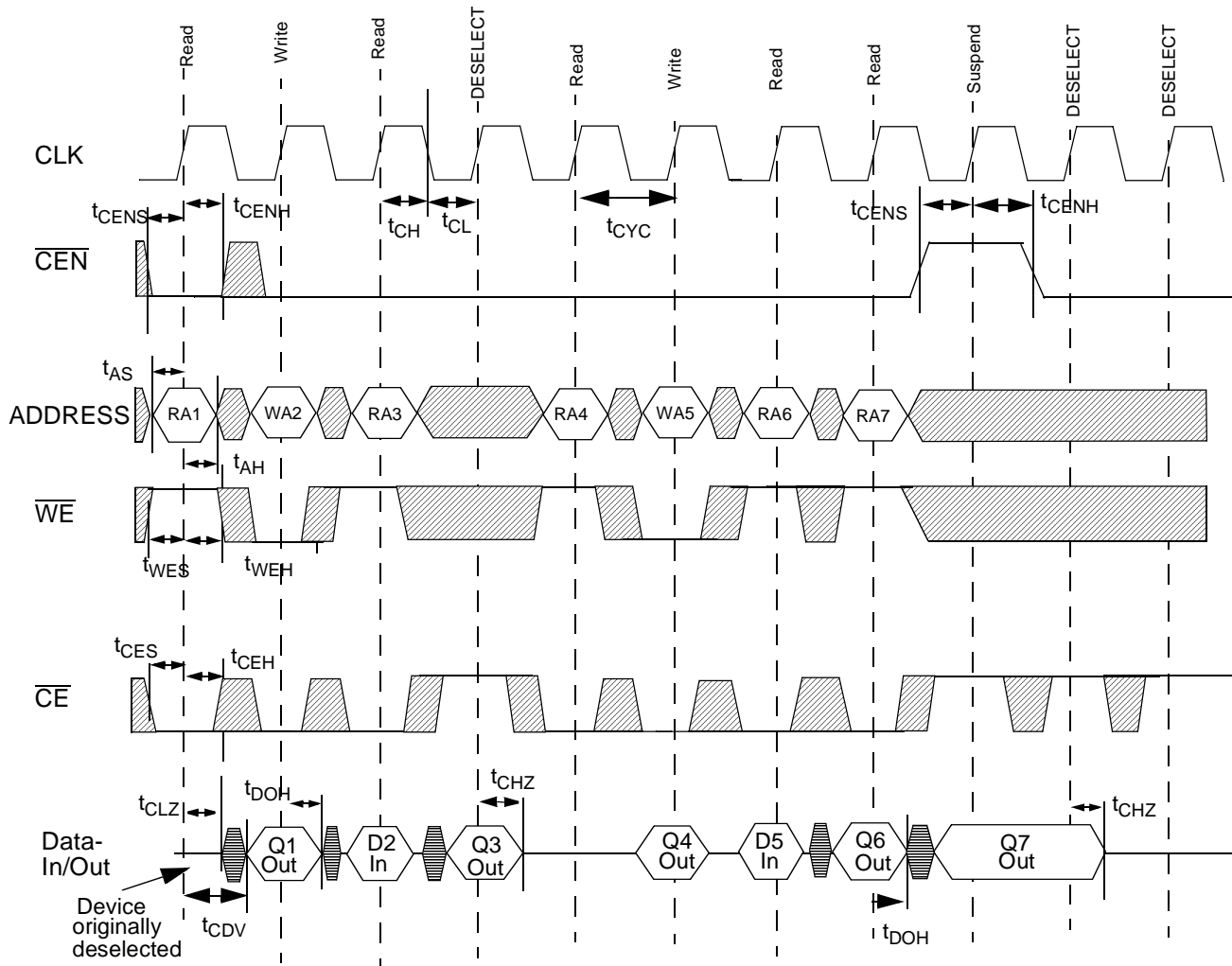
Switching Waveforms
Read/Write/Deselect Sequence

\overline{WE} is the combination of \overline{WE} & \overline{BWS}_x ($x = a, b, c, d$) to define a write cycle (see Write Cycle Description table).
 \overline{CE} is the combination of \overline{CE}_1 , CE_2 , and \overline{CE}_3 . All chip selects need to be active in order to select the device. Any chip select can deselect the device. RAX stands for Read Address X, WA stands for Write Address X, Dx stands for Data-in X, Qx stands for Data-out X.

Switching Waveforms (continued)

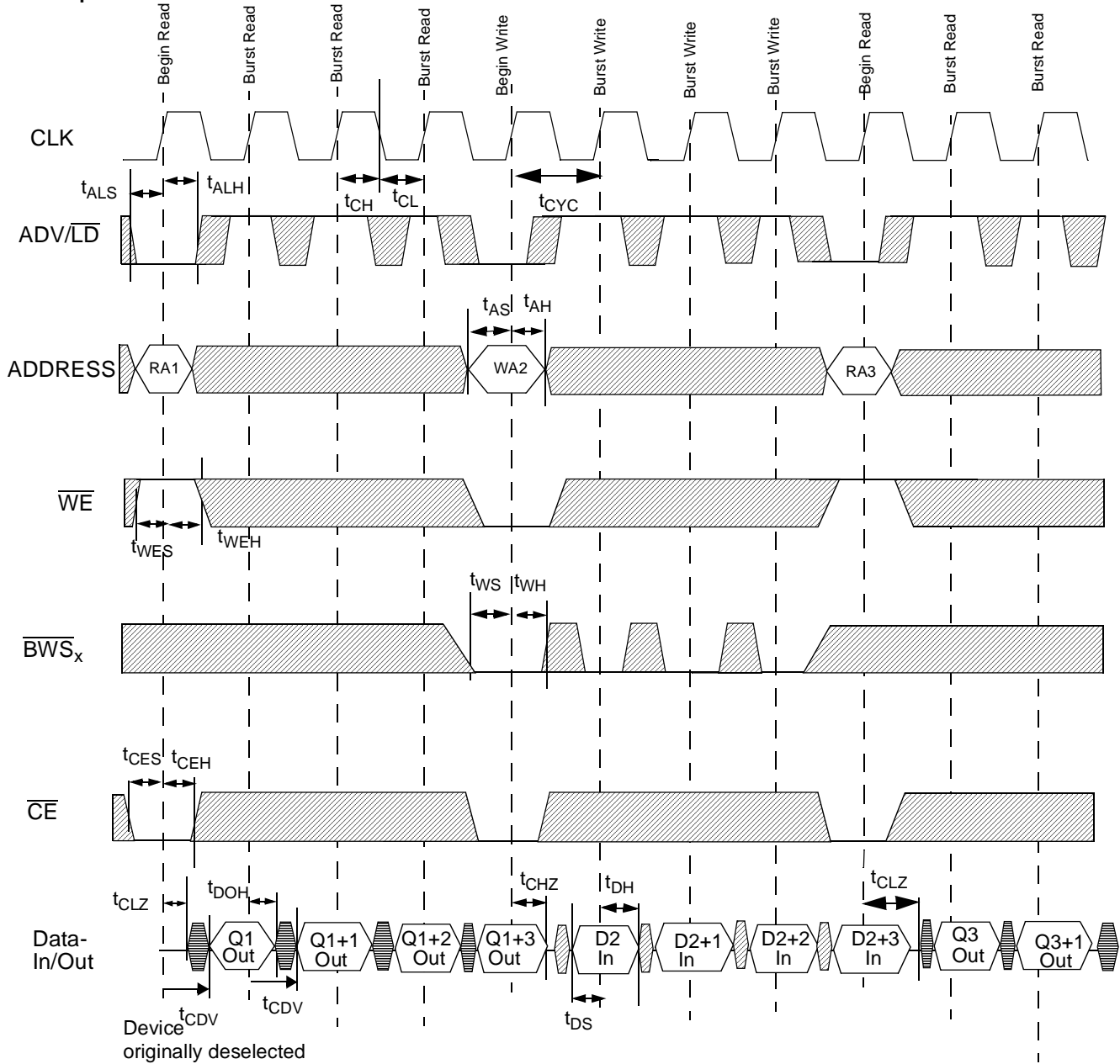
Burst Sequences

The combination of \overline{WE} & \overline{BWS}_x ($x = a, b, c, d$) define a write cycle (see Write Cycle Description table). \overline{CE} is the combination of \overline{CE}_1 , \overline{CE}_2 , and \overline{CE}_3 . All chip enables need to be active in order to select the device. Any chip enable can deselect the device. RAX stands for Read Address X, WA stands for Write Address X, Dx stands for Data-in for location X, Qx stands for Data-out for location X. \overline{CEN} held LOW. During burst writes, byte writes can be conducted by asserting the appropriate \overline{BWS}_x input signals. Burst order determined by the state of the MODE input. \overline{CEN} held LOW. \overline{OE} held LOW.

▨ = DON'T CARE ▩ = UNDEFINED

Switching Waveforms (continued)

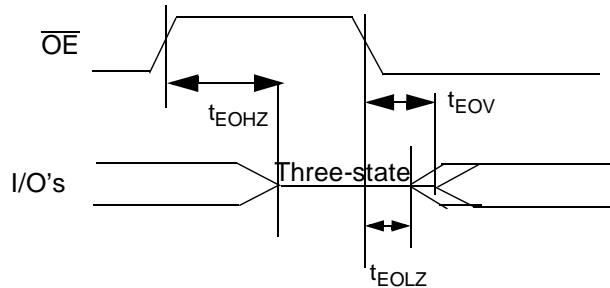
 \overline{OE} Timing

Ordering Information

Speed (MHz)	Ordering Code	Package Name	Package Type	Operating Range
133	CY7C1355V25-133AC/ CY7C1357V25-133AC	A101	100-Lead 14 x 20 x 1.4 mm Thin Quad Flat Pack	Commercial
	CY7C1355V25-133BGC/ CY7C1357V25-133BGC	BG119	119-Lead FBGA (14 x 22 x 2.4 mm)	
117	CY7C1355V25-117AC/ CY7C1357V25-117AC	A101	100-Lead 14 x 20 x 1.4 mm Thin Quad Flat Pack	
	CY7C1355V25-117BGC/ CY7C1357V25-117BGC	BG119	119-Lead FBGA (14 x 22 x 2.4 mm)	
100	CY7C1355V25-100AC/ CY7C1357V25-100AC	A101	100-Lead 14 x 20 x 1.4 mm Thin Quad Flat Pack	
	CY7C1355V25-100BGC/ CY7C1357V25-100BGC	BG119	119-Lead FBGA (14 x 22 x 2.4 mm)	
80	CY7C1355V25-80AC/ CY7C1357V25-80AC	A101	100-Lead 14 x 20 x 1.4 mm Thin Quad Flat Pack	
	CY7C1355V25-80BGC/ CY7C1357V25-80BGC	BG119	119-Lead FBGA (14 x 22 x 2.4 mm)	

Shaded areas contain advance information.

Package Diagrams

100-Pin Thin Plastic Quad Flatpack (14 x 20 x 1.4 mm) A101

DIMENSIONS ARE IN MILLIMETERS.

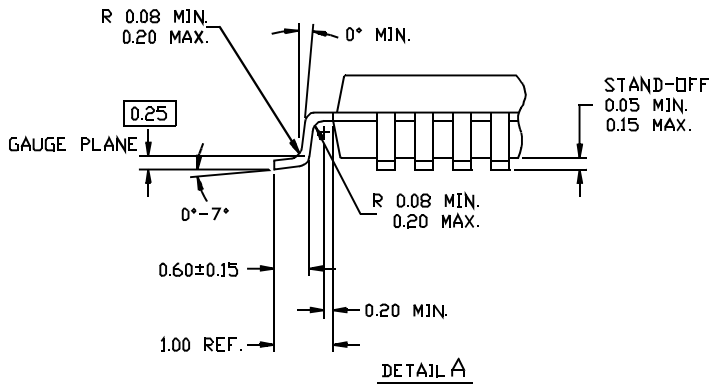
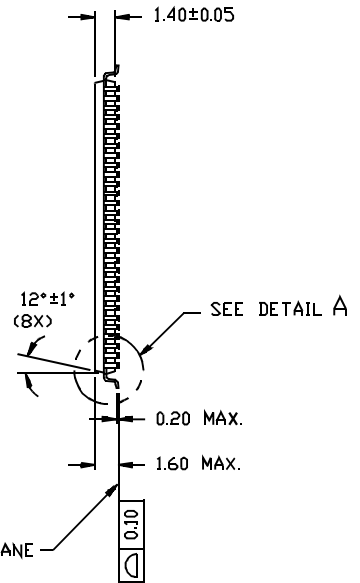
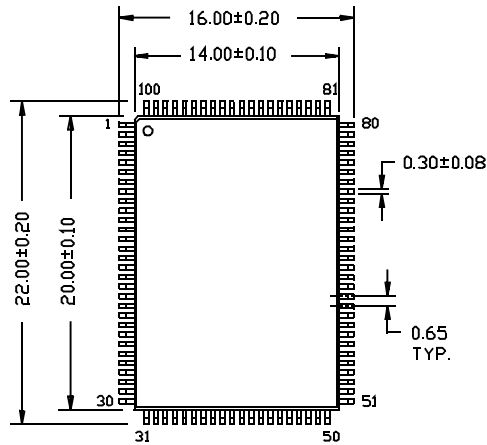

51-85050-A

Package Diagrams (continued)
119-Lead FBGA (14 x 22 x 2.4 mm) BG119

DIMENSION IN MILLIMETERS (INCHES)

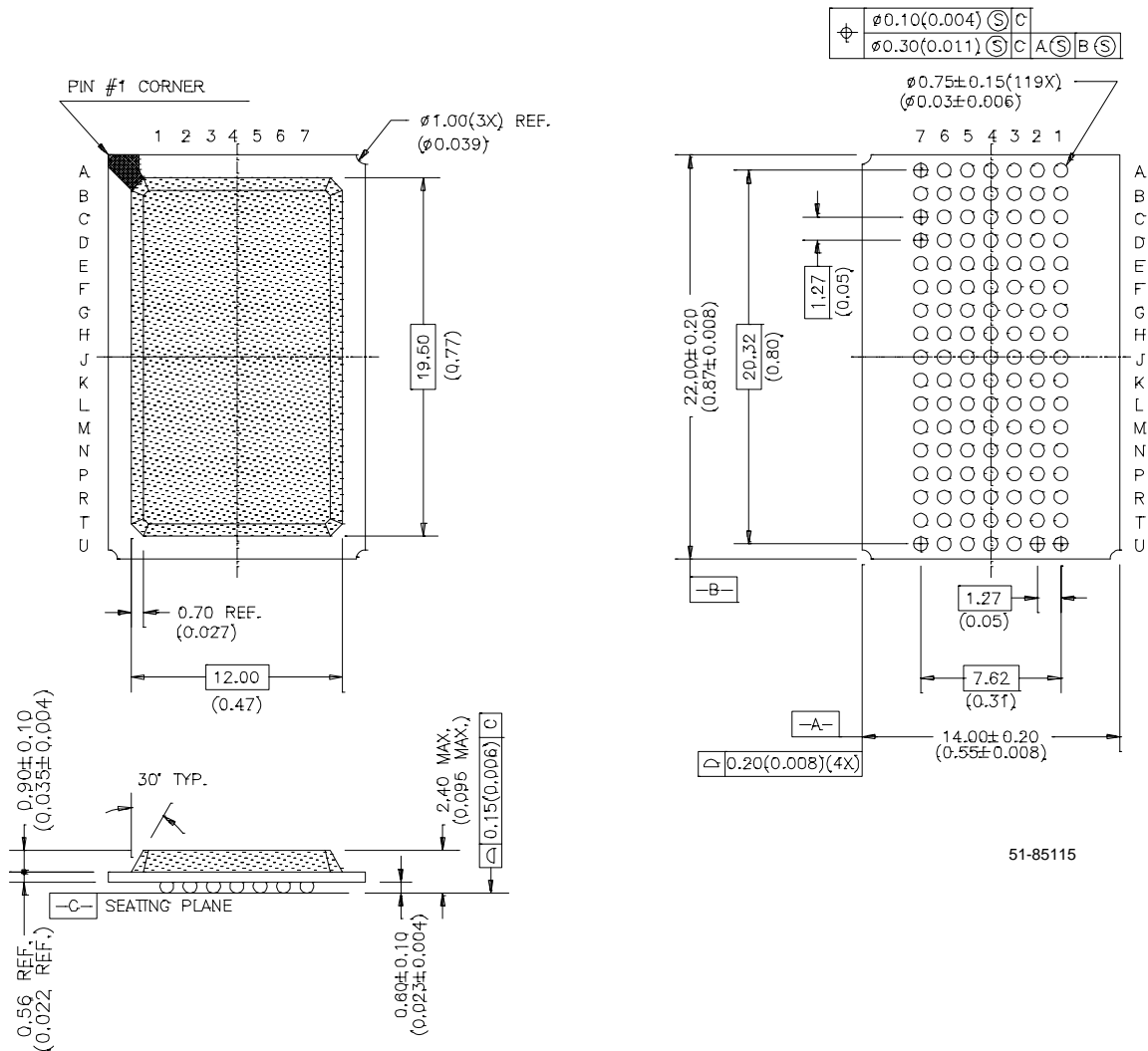
Revision History

Document Title: CY7C1355V25/CY7C1357V25				
Document Number: 38-00763				
REV.	ECN NO.	ISSUE DATE	ORIG. OF CHANGE	DESCRIPTION OF CHANGE
**	2563	4/29/99	SKX	1. New Data Sheet
*A	2682	9/10/99	SKX	1. Updated the BGA pinout 2. Added revision history